

EN



Before You Start

- ⚠ Please read all instructions carefully.
- ⚠ Retain instructions for future reference.
- ⚠ Separate and count all parts and hardware.
- ⚠ Read through each step carefully and follow the proper order.
- ⚠ We recommend that, where possible, all items are assembled near to the area in which they will be placed in use, to avoid moving the product unnecessarily once assembled.
- ⚠ Always place the product on a flat, steady and stable surface.
- ⚠ Keep all small parts and packaging materials for this product away from babies and children as they potentially pose a serious choking hazard.

FR



Avant de Commencer

- ⚠ Veuillez lire attentivement toutes les instructions.
- ⚠ Conservez les instructions pour vous y référer ultérieurement.
- ⚠ Vérifiez toutes les pièces et les accessoires.
- ⚠ Lisez attentivement chaque étape et suivez l'ordre correct.
- ⚠ Nous recommandons que, dans la mesure du possible, tous les produits soient assemblés à proximité de la zone où ils seront utilisés, afin d'éviter tout déplacement inutile du produit une fois assemblé.
- ⚠ Placez toujours le produit sur une surface plane et stable.
- ⚠ Conservez toutes les petites pièces de ce produit et les matériaux d'emballage hors de portée des bébés et des enfants, car ils pourraient présenter un risque d'étouffement.

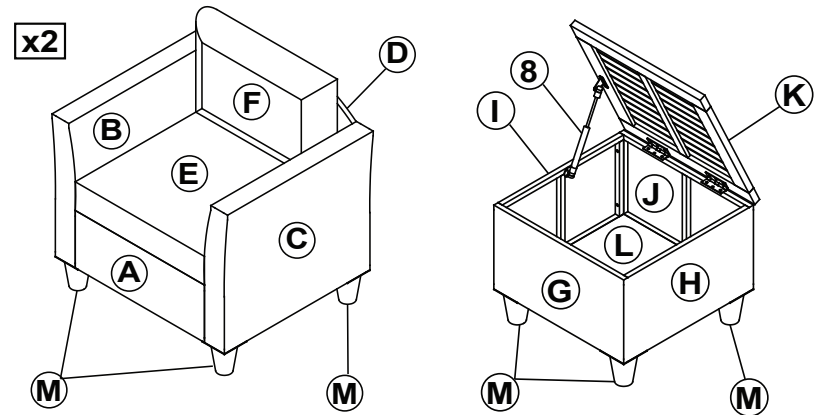





EN: Notice

- 50% tighten before fixing all screws. Allen wrench is recommended instead of an electric drill.
- Place the item on a flat ground to adjust and make sure it remains stable.
- Tighten up all screws with tools gradually.
- If the screws are not aligned with holes during assembly, please loosen all the other screws to 50% and continue the assembly process.
- If the item is not stable, please loosen all the screws, adjust it on a flat ground and tighten up all screws again.
- Note: If one or some screws are fully tightened during assembly, the others may not be aligned with the holes. In addition, all the holes are designed to be relatively larger to provide more space for the adjustment of the screws.

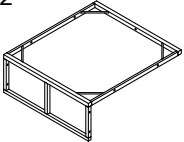
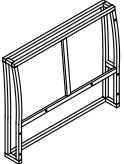
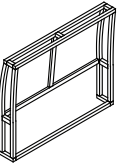
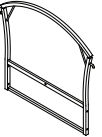
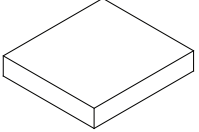
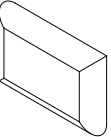
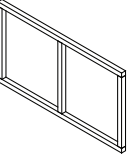
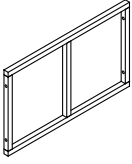
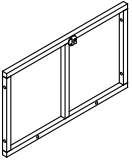
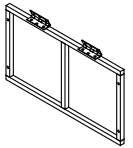
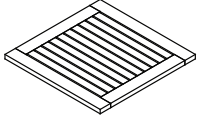
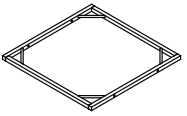
FR: Remarque

- Serrez à 50% avant de fixer toutes les vis. Une clé Allen est recommandée à la place d'une perceuse électrique.
- Placez l'article sur un sol plat pour régler et assurez-vous qu'il reste stable.
- Serrez progressivement toutes les vis avec des outils.
- Si les vis ne sont pas alignées avec les trous lors de l'assemblage, veuillez desserrer toutes les autres vis à 50% et poursuivre le processus d'assemblage.
- Si l'article n'est pas stable, veuillez desserrer toutes les vis, l'ajuster sur un sol plat et resserrer toutes les vis.
- Remarque : Si une ou plusieurs vis sont complètement serrées lors du montage, les autres peuvent ne pas être alignées avec les trous. De plus, tous les trous sont conçus pour être relativement plus grands afin de fournir plus d'espace pour le réglage des vis.

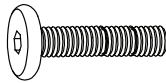
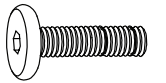
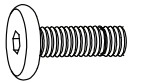
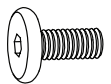
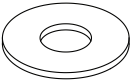
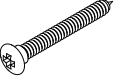
A x2  Seat frame of armless chair / Cadre de siège de la chaise amrless	B x2  Right arm / Bras droite	C x2  Left arm / Bras gauche
D x2  Back frame of armless chair / Cadre du dossier de la chaise sans accoudoirs	E x2  Seat cushion of armless chair / Coussin d'assise de la chaise sans accoudoirs	F x2  Back cushion of armless chair / Coussin de dossier de chaise sans dossier
G x1  Front frame of table / Cadre avant de la table	H x1  Left frame of table / Cadre gauche de la table	I x1  Right frame of table / Cadre droite de la table
J x1  Back frame of table / Cadre arrière de la table	K x1  Wooden table top / Plateau de table en bois	L x1  Bottom frame of table / Cadre inférieur de la table
M x12  Wooden legs of armless chair & table / Pieds en bois de la chaise et de la table sans accoudoirs		

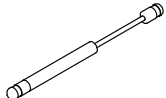
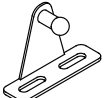
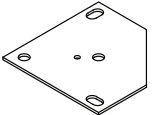
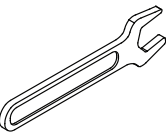
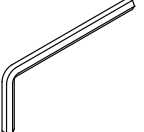
1 x2  Bolt M6x40mm / Boulon M6x40mm	2 x24  Bolt M6x35mm / Boulon M6x35mm	3 x12  Bolt M6x30mm / Boulon M6x30mm
4 x36  Bolt M6x15mm / Boulon M6x15mm	5 x74  Steel washer M6x14x1mm / Rondelle d'acier M6x14x1mm	6 x18  Screw M4x15mm / Vis M4x15mm
7 x12  Nut M8x5x12mm / Écrou M8x5x12mm	8 x1  Gas bar / Barre à gaz	9 x1  Gas bar support / Support de barre de gaz
10 x12  	11 x1  Wrench M13 / Clé à molette M13	12 x2  Allen key M4 / Clé Allen M4

01

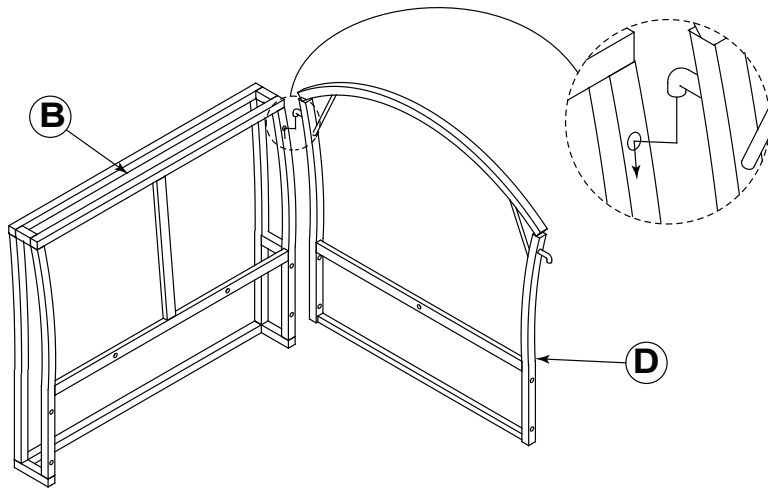

03

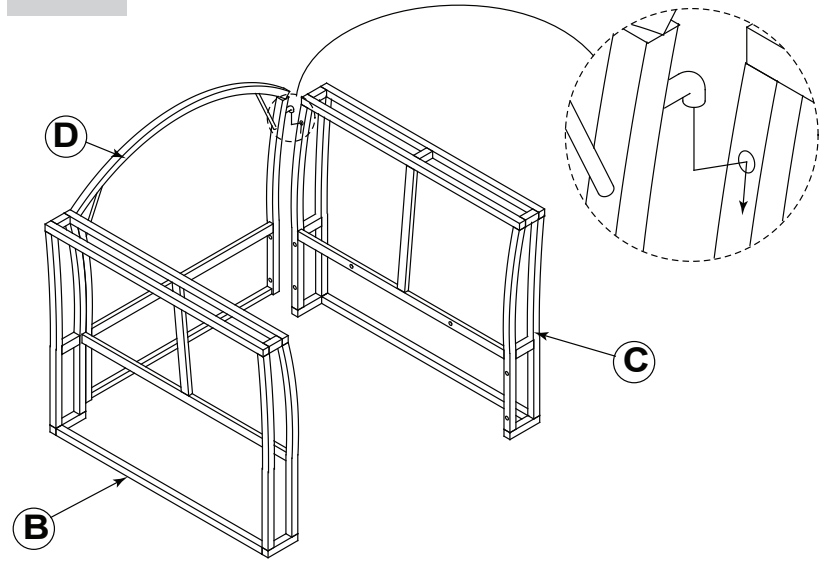

02

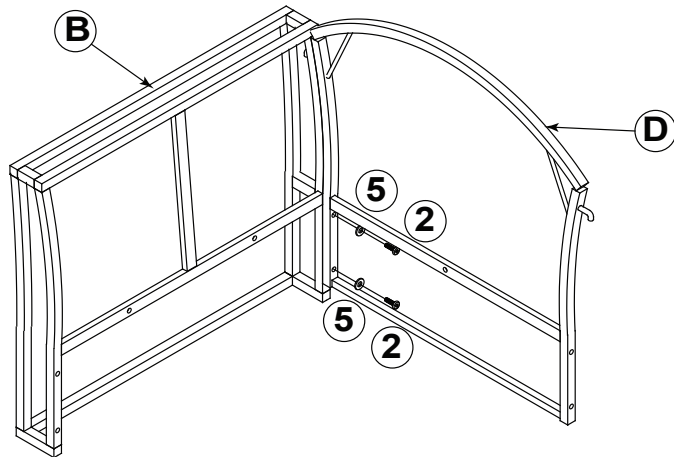

04

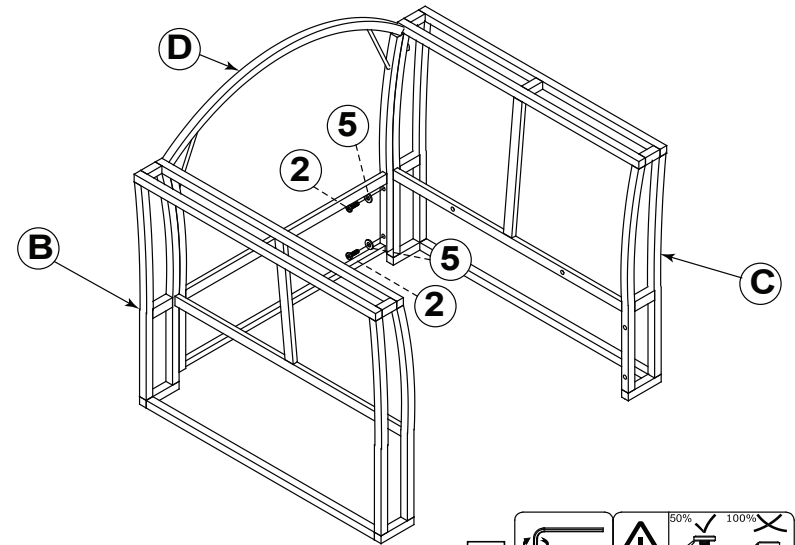

05

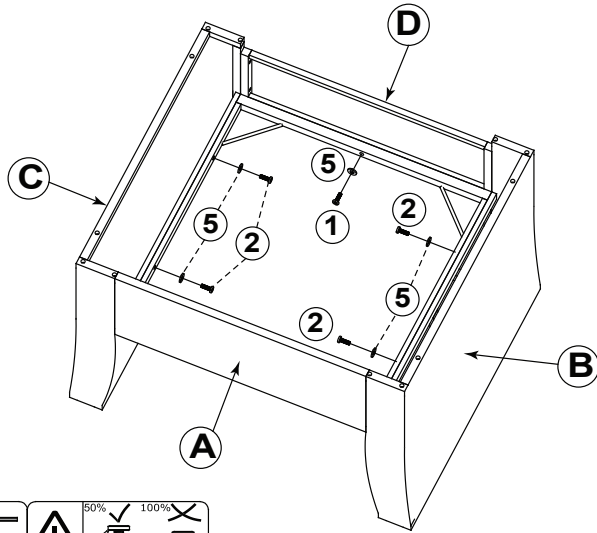

07

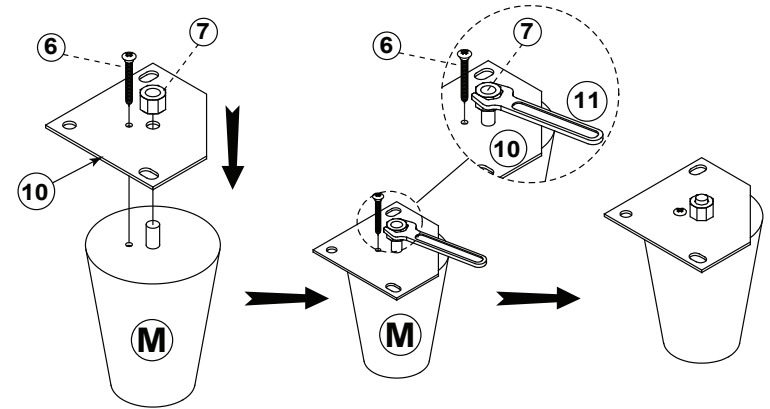

06

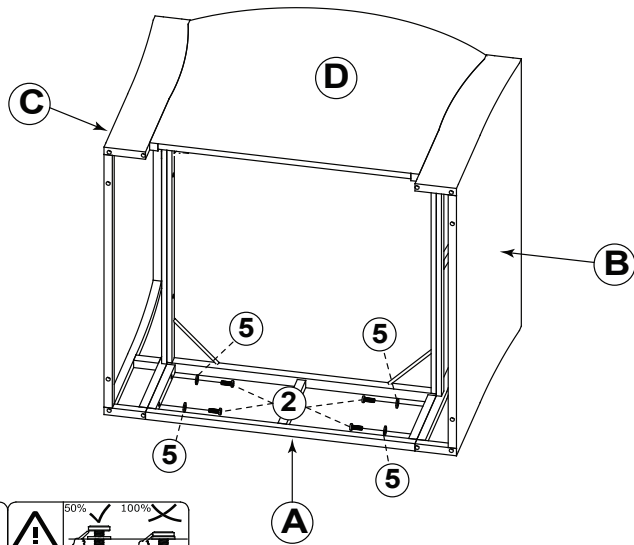

08

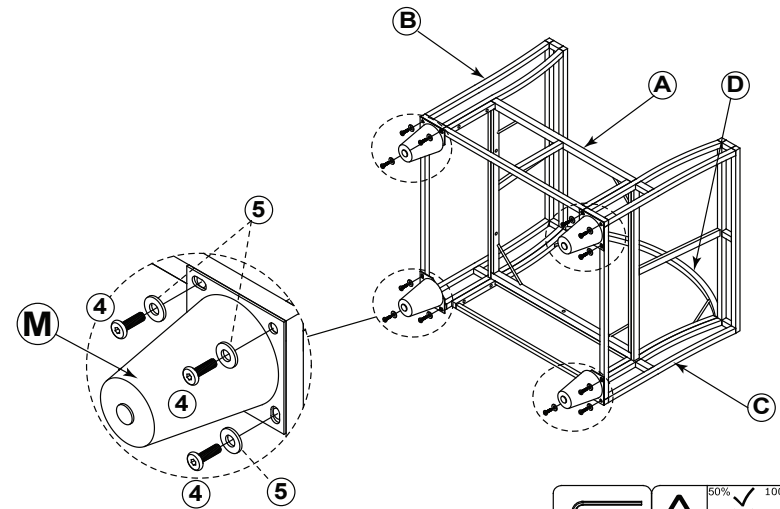

09

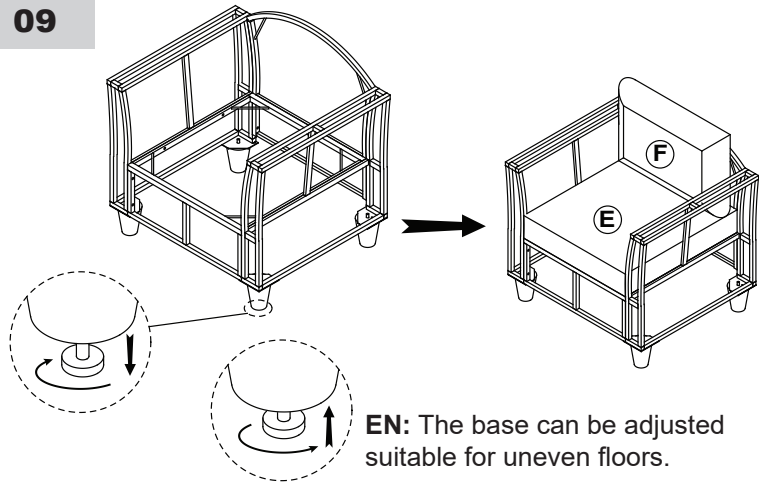

EN: The base can be adjusted suitable for uneven floors.

FR: La base peut être ajustée pour s'adapter aux sols irréguliers

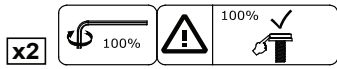

11

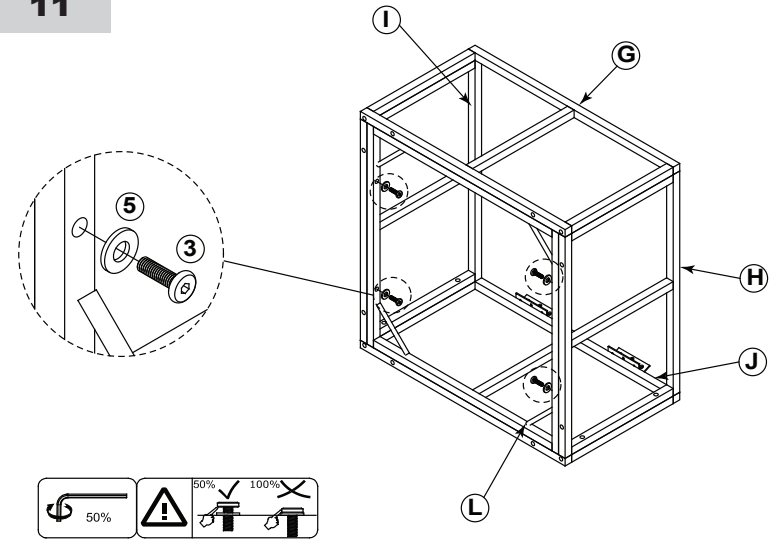

10

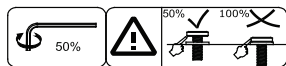
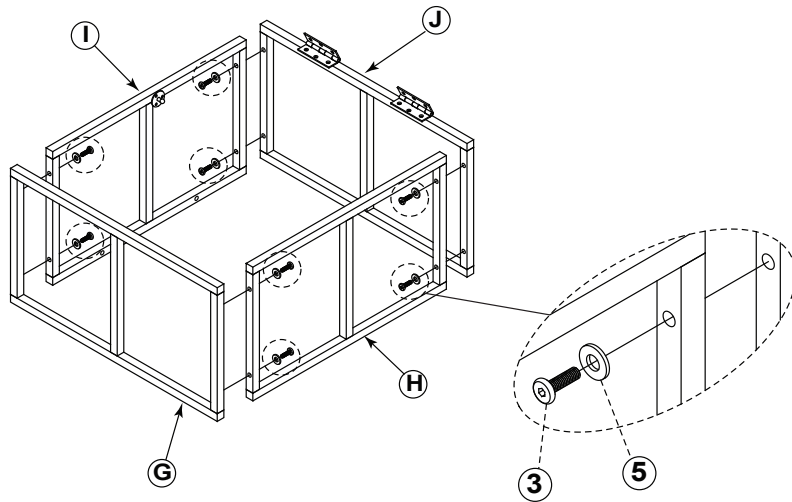

12

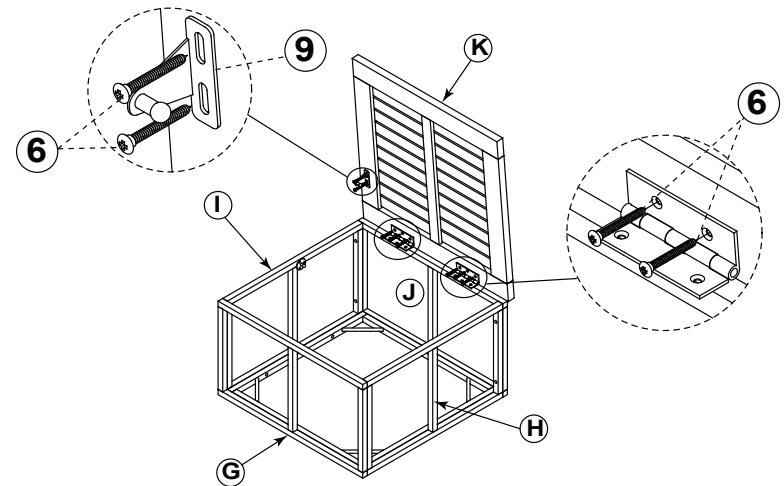

13

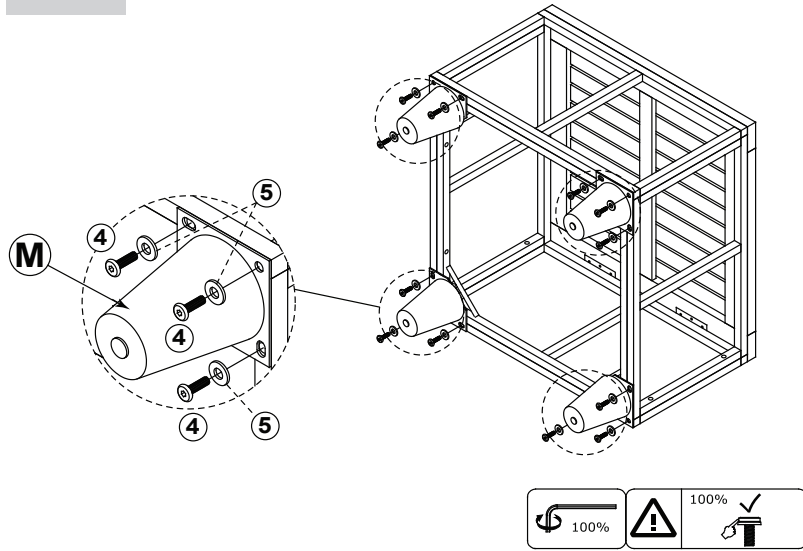

15

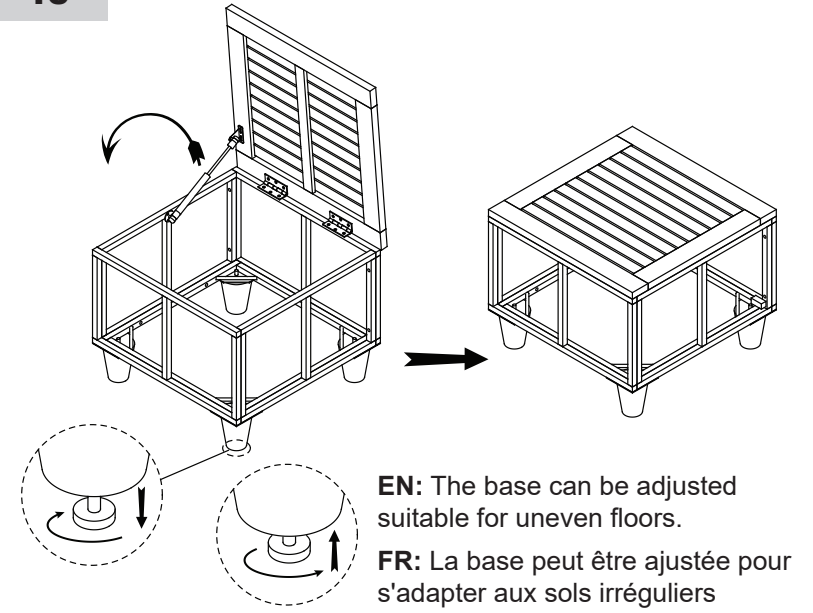

14

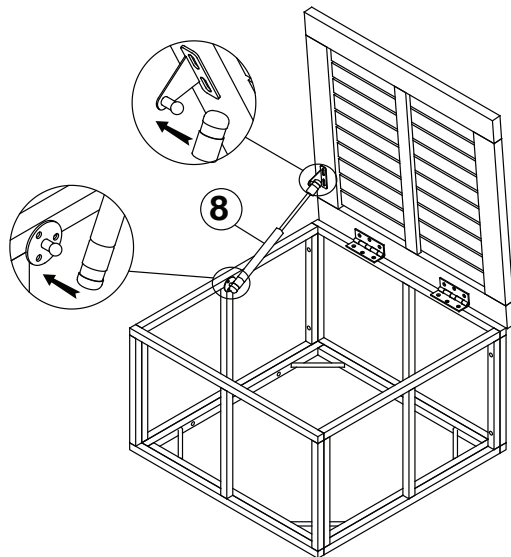



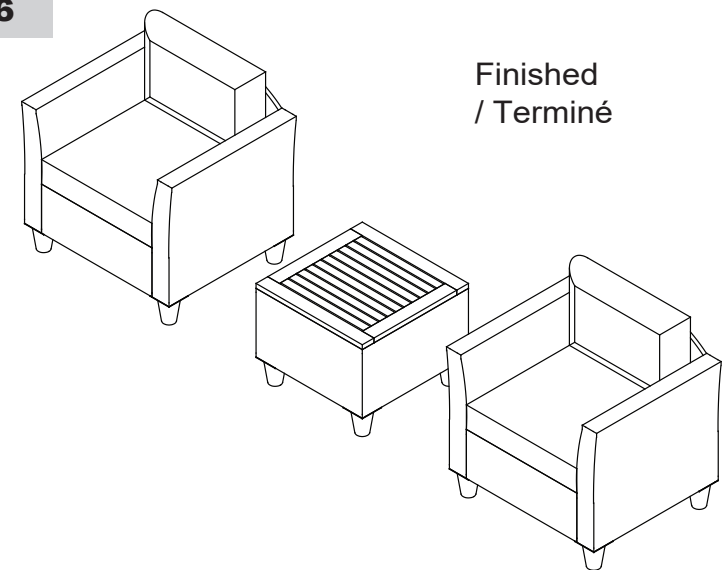

16



EN







Return / Damage Claim Instructions

-  **DO NOT discard the box / original packaging.**
In case a return is required, the item must be returned in original box. Without this your return will not be accepted.
-  **Take a photo of the box markings.**
A photo of the markings (text) on the side of the box is required in case a part is needed for replacement. This helps our staff identify your product number to ensure you receive the correct parts.
-  **Take a photo of the damaged part (if applicable).**
A photo of the damage is always required to file a claim and get your replacement or refund processed quickly. Please make sure you have the box even if it is damaged.
-  **Send us an email with the images requested.**
Email us directly from marketplace where your item was purchased with the attached images and a description of your claim.

FR



Instructions De Retour / Réclamation De Dommages

-  **NE PAS jeter la boîte/l'emballage d'origine.**
Dans le cas où un retour est requis, l'article doit être retourné dans sa boîte d'origine. Sans cela, votre retour ne sera pas accepté.
-  **Prenez une photo des marquages de la boîte.**
Une photo des marquages (texte) sur le côté de la boîte est requise au cas où une pièce serait nécessaire pour le remplacement. Cela aide notre personnel à identifier votre numéro de produit pour s'assurer que vous recevez les bonnes pièces.
-  **Prenez une photo des dommages (le cas échéant).**
Une photo des dommages est toujours requise pour déposer une réclamation et obtenir rapidement votre remplacement ou votre remboursement. Assurez-vous d'avoir la boîte même si elle est endommagée.
-  **Envoyez-nous un e-mail avec les images demandées.**
Envoyez-nous un e-mail directement depuis le marché où votre article a été acheté avec les images ci-jointes et une description de votre réclamation.