



Tilt-a-Rack Mobility Carrier Instructions for Part # TWSC-350

General Guidelines

- It is the user's responsibility to read and follow all instructions.
- Keep these instructions with the product at all times and review before each use.
- It is the responsibility of this product's owner to furnish the instructions to any person that borrows or purchases the product.
- Inspect the product before use to ensure it is assembled properly and all parts are in safe working order and free of defects.
- Never modify this product in any way.
- All circumstances cannot be addressed in these instructions. Please use common sense and practice general safety measures when using this product.
- Parts and/or instructions are subject to change without notice.

Safety

- Follow all warnings and instructions marked on the product.
- Do not occupy the mobility aid while loading the carrier.
- Do not stand on the carrier.
- Once the mobility aid is loaded, always make sure the deck is locked in the level position and the safety gates are locked in place.
- Always carefully secure the load on the carrier. Tie-down straps are sold separately.
- It is recommended to use an assistant to help install the carrier into the vehicle hitch.
- Never exceed vehicle tongue weight rating.
- Do not exceed the 350 lb weight capacity.
- Hitch adapters may affect the weight capacity of the carrier. If using a hitch adapter, always check its limitations before use.
- Always store the carrier in a safe place.
- Improper use, storage, or installation of the carrier could result in death or serious injury.
- Do not put the product on any kind of trailer.
- NOT recommended for tow-behind trailers including 5th wheel trailers and camping trailers.
- Periodically check nuts and bolts for tightness.

Parts

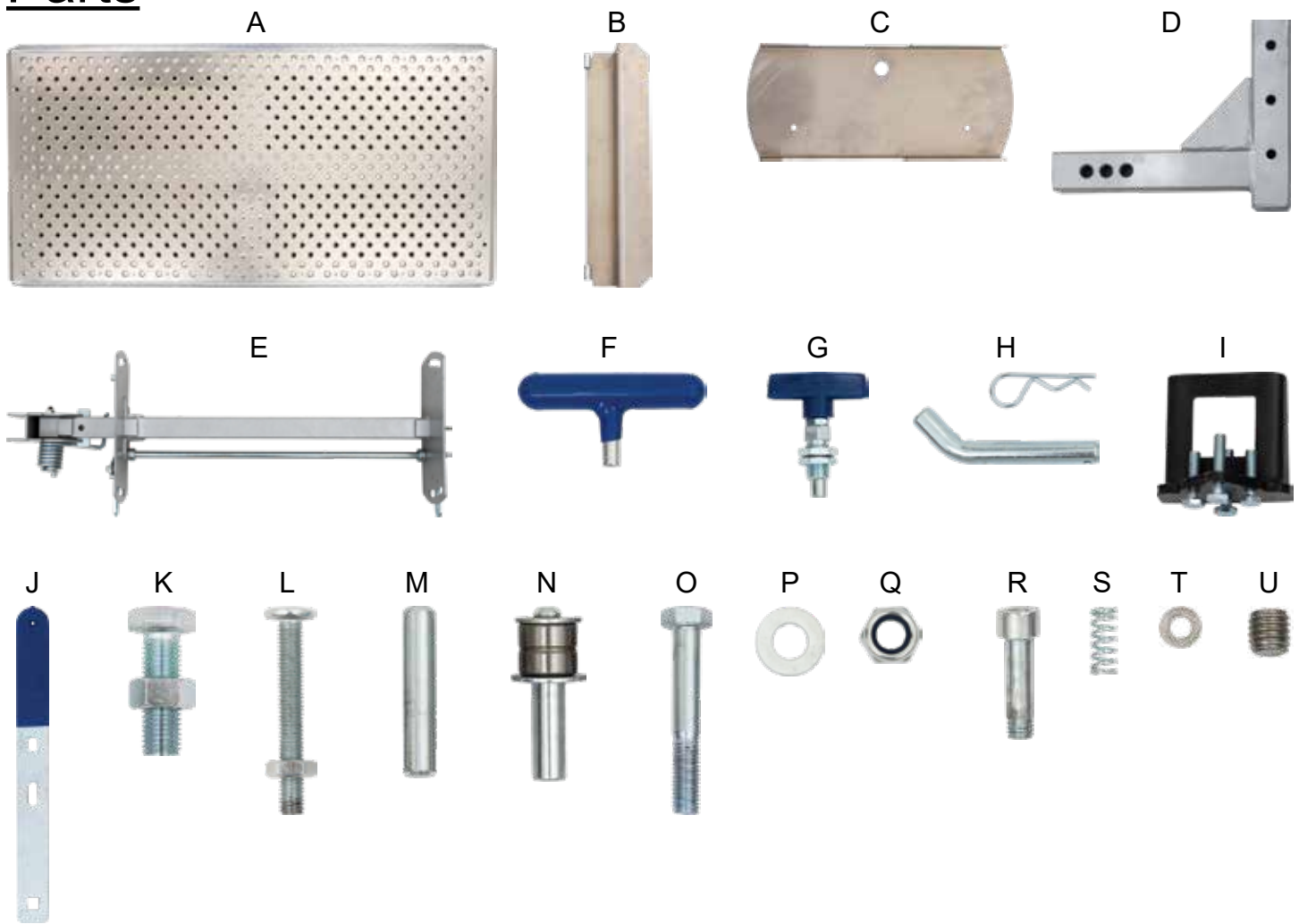

Part	Description	Quantity
A	Carrier Deck	1
B	Safety Gate	2
C	Front Cover Plate	1
D	Hitch Tube/Riser	1
E	Carrier Hitch Tube Assembly	1
F	Folding Handle	1
G	Spring Handle	4
H	Hitch Pin and Clip	1
I	Anti-Tilt	1
J	Tilting Handle	1
K	M20x62 Leveler Bolt w/Jam Nut	1

Part	Description	Quantity
L	M8x60 Allen Head Bolt w/Jam Nut	2
M	Frame Pin	4
N	Roller Frame Pin	4
O	M12x80 Bolt	2
P	M12 Washer	4
Q	M12 Nut	2
R	M8x30 Socket Screw	1
S	Spring	1
T	M8 Washer	1
U	M8x8 Set Screw	8

Tools Required

- Wrenches - 13mm, 14mm, 16mm, 17mm, 19mm, 22mm, 30mm or large adjustable wrench
- Allen wrenches - 4mm (included), 5mm, 6mm

Assembly

Step 1. Place the carrier deck (A) upside-down on a flat, level surface. Attach the carrier hitch tube assembly (E) to the carrier deck (A) using the four roller frame pins (N) and four set screws (U). Tighten securely with a 4mm Allen wrench. (See fig. 1-2 below.)

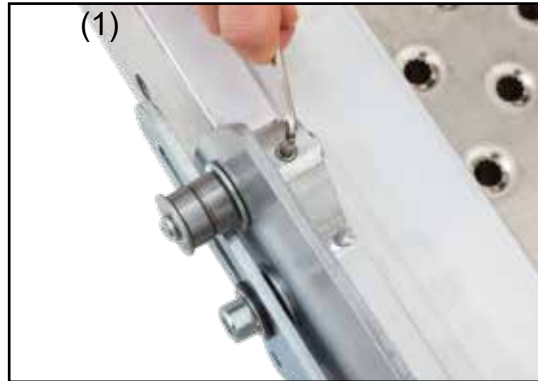

Step 2. Attach the safety gates (B) to the carrier deck (A) using the four frame pins (M) and four set screws (U). Tighten securely with a 4mm Allen wrench.

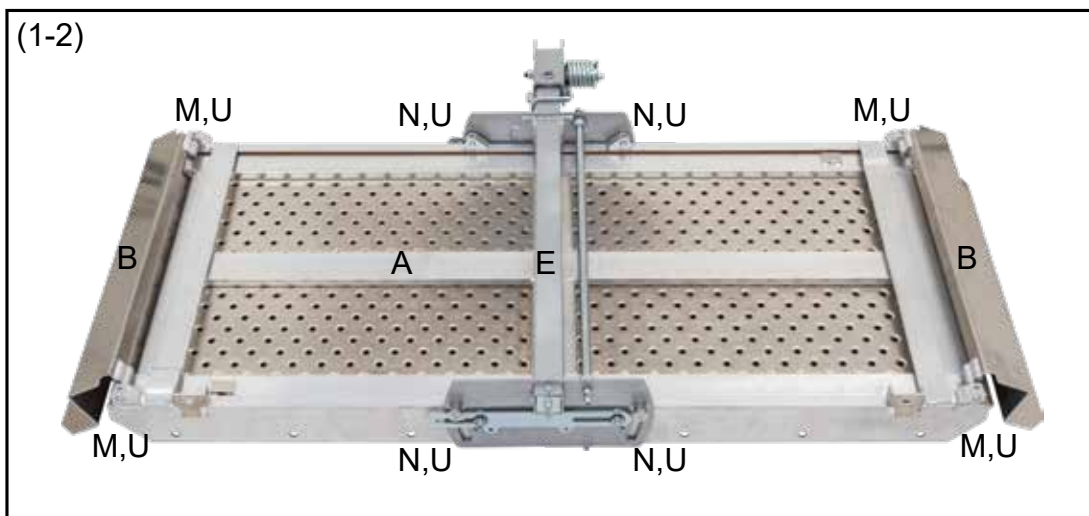
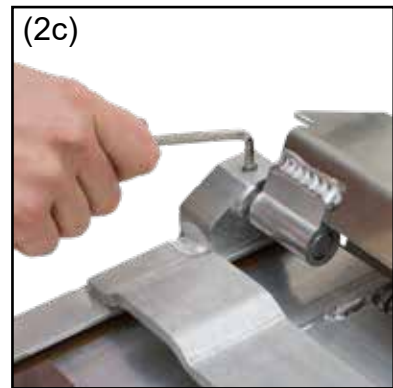
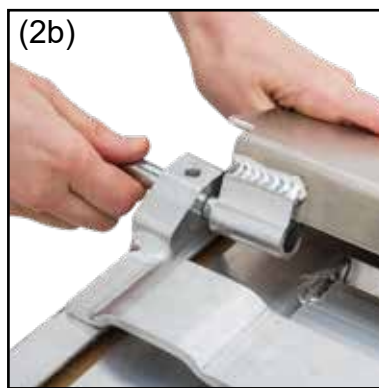
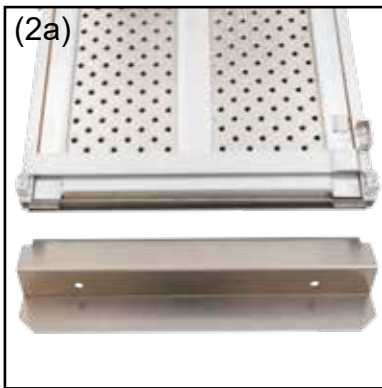

Step 3. Flip the carrier assembly right-side-up. It may be helpful to set it on blocks for easier assembly. Remove the washer and nut from the front of the carrier hitch tube assembly (E). (If needed, use a 13mm wrench.) Fit the tilting handle (J) onto the extended bolts, then replace the washer and nut and tighten with a 13mm wrench.

Step 4. Add the washer (T), spring (S), and socket screw (R) into the center hole of the tilting handle (J). Secure with a 6mm Allen wrench.

Step 5. Loosen the jam nut on the lower part of the carrier hitch tube assembly so it is threaded about 1/2" from the end of the threaded rod. (If needed, use a 13mm wrench.) This can be adjusted later.

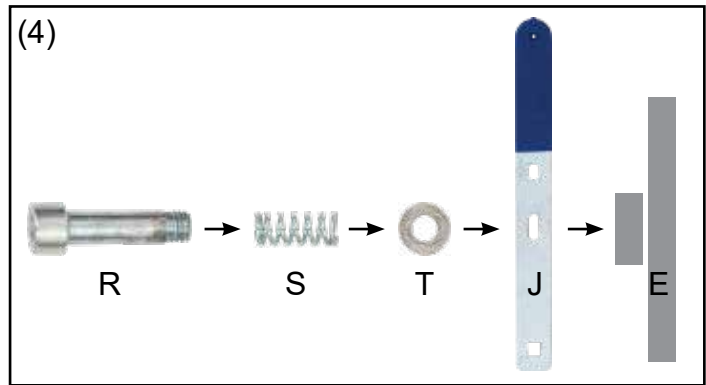
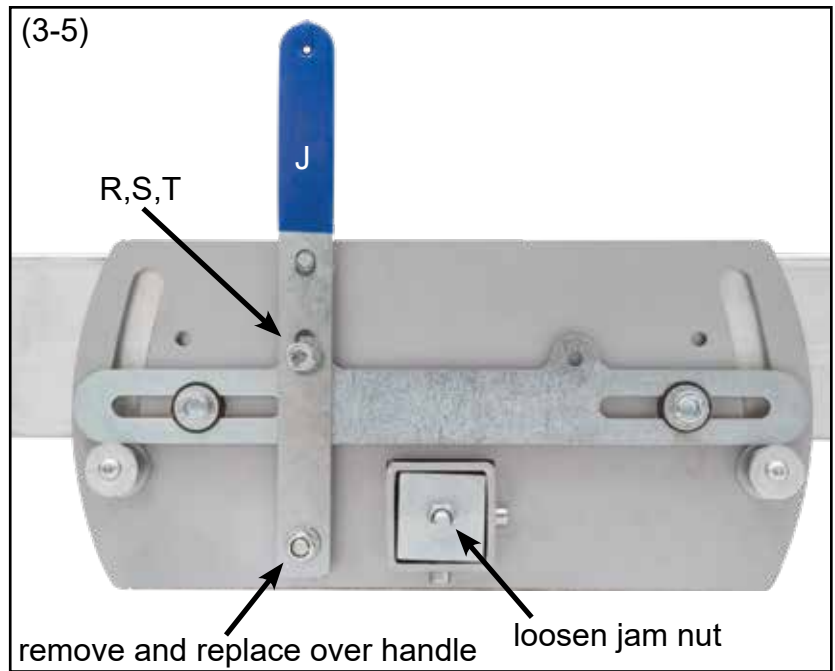

Step 6. Attach the front cover plate (C) over the handle mechanism using the two Allen head bolts with jam nuts (L). Place the bolts through the cover plate holes, then add the jam nuts onto the ends of the bolts, threading about 1/2" up. Fit the bolts into the carrier hitch tube assembly and tighten with a 5mm Allen wrench. Then, tighten the jam nuts so they fit against the carrier hitch tube assembly using a 14mm wrench.

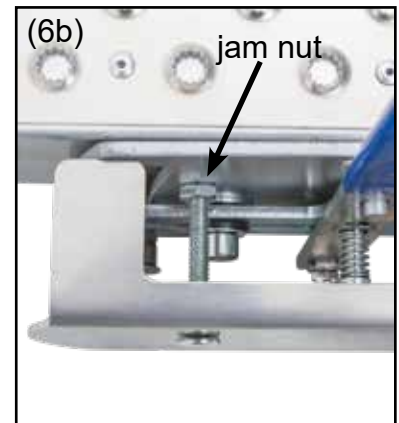
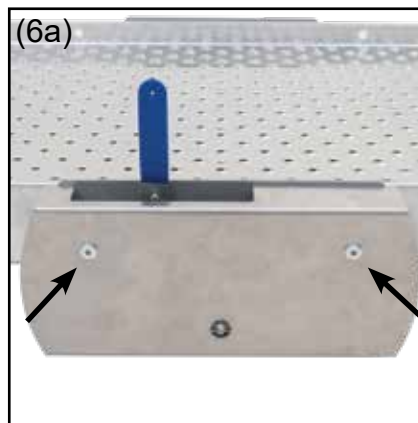

Step 7. Attach the folding handle (F) by threading it into the lower hole of the front cover plate. The jam nut that was loosened in Step 5 may now be adjusted if needed so that the handle is secure yet easy to grip. The jam nut can be accessed from underneath the assembled front handle box using a 13mm wrench. **NOTE: The handle must be installed parallel to the carrier deck.**

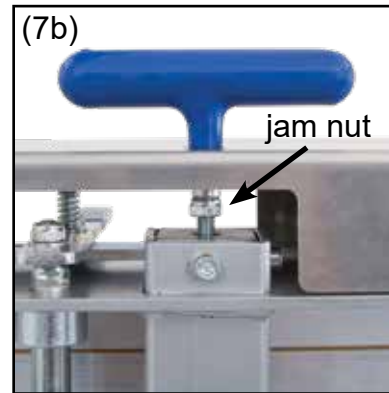
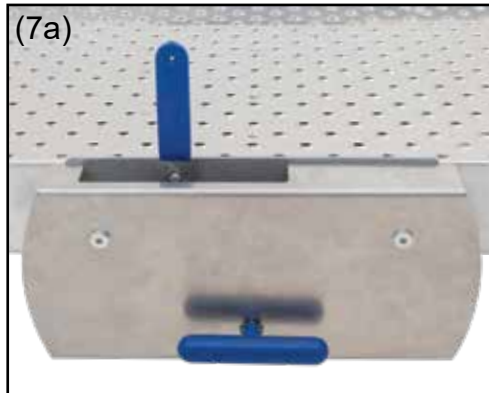

Step 8. Attach the spring handles (G) to the safety gates (B). Remove the bottom nut, place the handle post into the hole, then reattach the nut. Adjust the nuts on the spring handles as needed so they are secure, but will easily release the gates when pulled. Use a 16mm wrench for the top nut and 22mm or large adjustable wrench for the lower jam nuts.

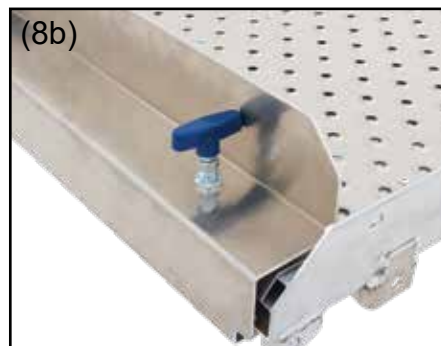
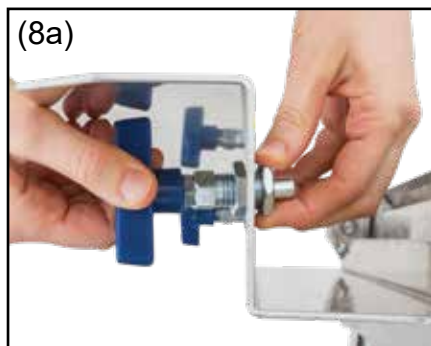

Step 9. Attach the hitch tube/riser (D) to the back of the carrier hitch tube assembly (E) using the M12x80 bolts (O), washers (P), and nuts (Q). Two height options are available - choose what is appropriate for your vehicle. The hitch tube may also be used as a drop when using the setting as shown below. Secure with 19mm wrenches.

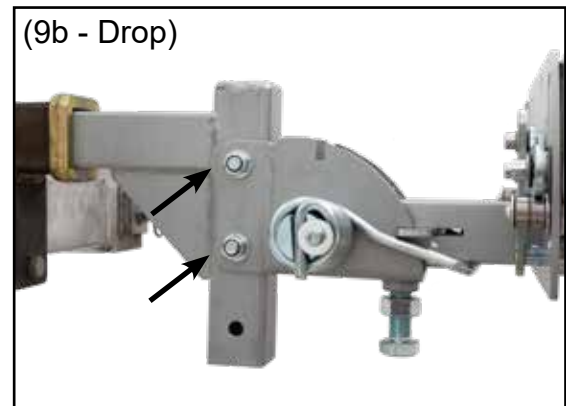
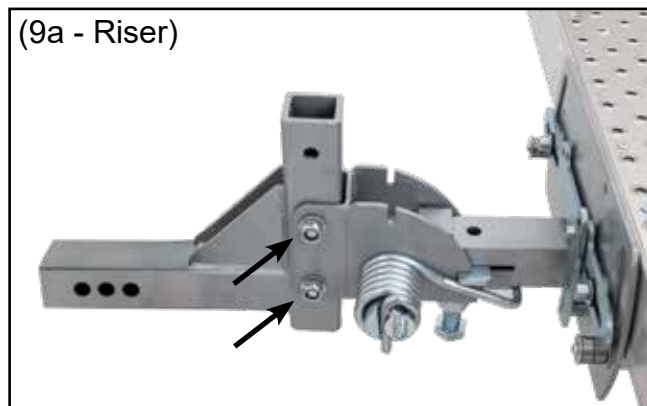

Step 10. Insert the leveler bolt and jam nut (K) into the hole at the bottom of the carrier hitch tube assembly towards the hitch receiver end. This can be adjusted when the carrier is on the vehicle.

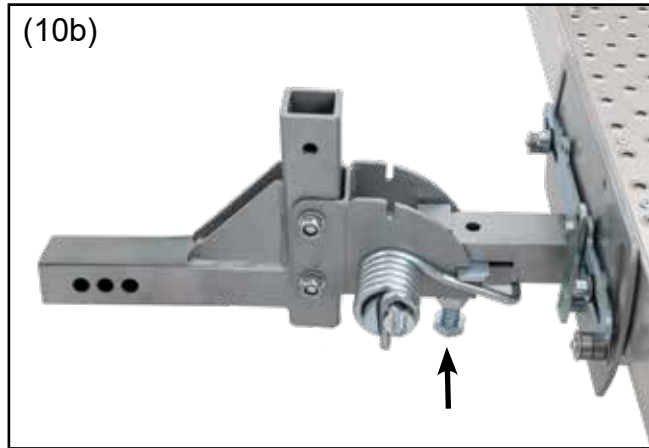
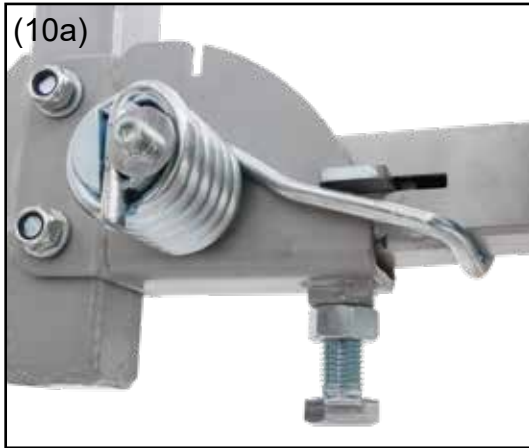

Use/Installation

Anti-Tilt: Slide the anti-tilt bracket (I) over the carrier hitch tube with the 3-bolt side facing the vehicle. With an assistant, insert the carrier into the trailer hitch. Install the hitch pin (H), then tighten the four anti-tilt bolts evenly with a 17mm wrench. They will pinch the bracket on the collar and hitch, preventing excessive movement of the carrier.



Leveler Bolt: Adjust the leveler bolt so that all play is eliminated in the sliding flat lock bar. The leveler bolt should not be too tight; the lock bar should slide freely when pulling the folding handle.

Thread the jam nut towards the head of the bolt. Fully tighten the bolt into the carrier tube. Then tighten the jam nut against the carrier to secure the bolt. Use a 30mm or large adjustable wrench.

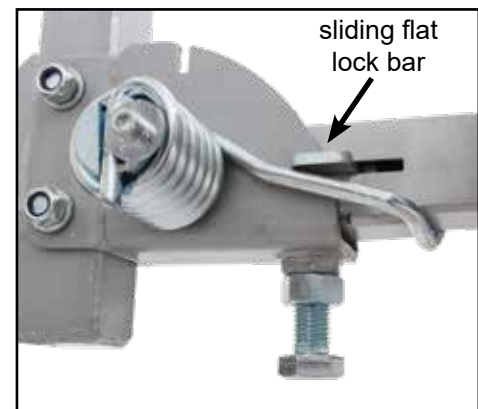

Extending the Deck: Release the safety gate on the side that you want to extend the deck. Pull up on the spring handles to release the gate, then rotate it down underneath the deck. Move the front tilt handle in the direction you want to extend the deck. Carefully pull out the deck extension, then tilt the carrier down for loading or unloading.

Release the safety gate

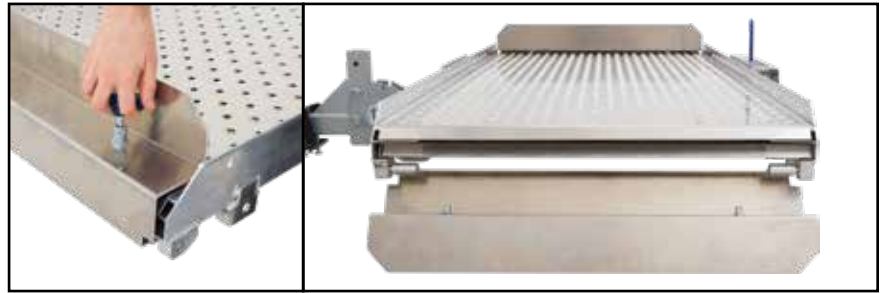

Extend the deck

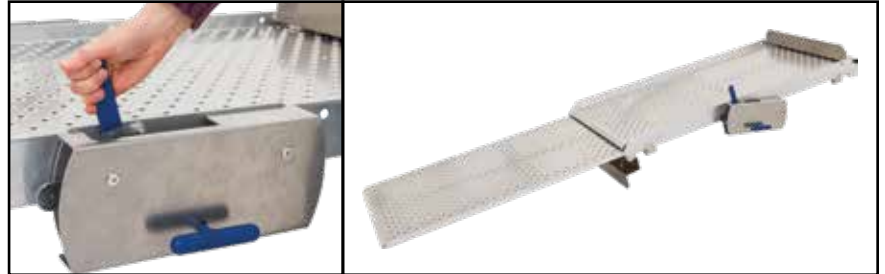

Stowing the Deck Extension: Tilt the deck into a level position, then slide the extension back into the deck. Move the tilt handle to the center position to lock it in place. **WARNING: The handle must be locked in the middle position before transporting.** Rotate the safety gate back into place, making sure it is secured with the spring handle pins.

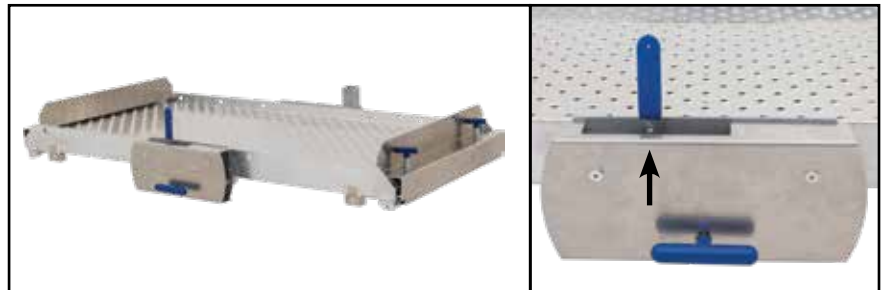

Folding the Carrier: Pull the front handle to unlock the folding mechanism. Carefully tilt the carrier deck up, making sure it locks in place.

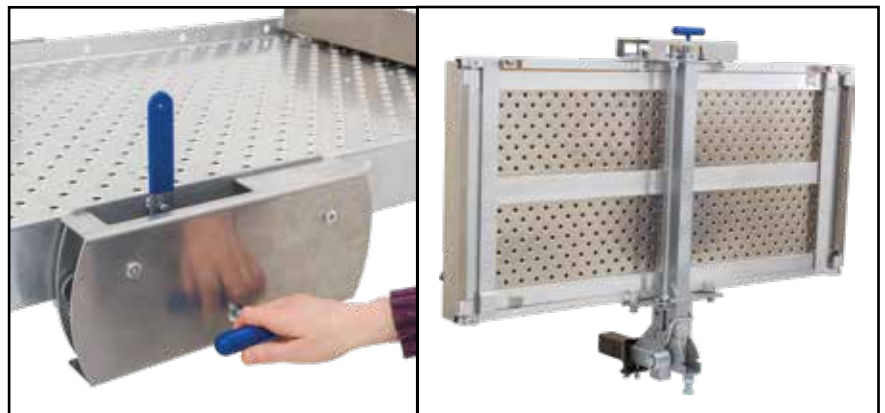

Product Warranty and Liability

GENERAL PRODUCT WARRANTY: Products purchased from the Authorized Dealer (original place of purchase) or Merchant (“Dealer”) will be free of defects in material and workmanship at the time of receipt, and will meet the specifications stated at the place of purchase transaction or online at the Dealer’s website, under normal use and service when correctly installed, operated and maintained. This product warranty is effective for the period of time stated below, unless otherwise stated in the product instructions or depicted in the product advertisement. **All Authorized Dealer warranties are NON-TRANSFERABLE** and cover only the original end purchaser. This limited warranty does not cover products purchased through non-authorized dealers. Non-authorized dealer receipts are not accepted for warranty verification.

*****Warranty claims must be made directly to the original place of purchase.*****

WARRANTY PERIOD: This warranty remains in force for one year from the date of the product’s accepted delivery. The Authorized Dealer offers a one year manufacturer’s warranty for most products unless otherwise specified on the product advertisement.

WARRANTY SERVICE: The Authorized Dealer will replace any defective or malfunctioning part at no charge, including payment of the shipping costs of parts or replacement product to and from the manufacturer. The purchaser is responsible for labor charges. If the product does not meet specifications as depicted in the advertisement, the Authorized Dealer will refund the full purchase price of the product.

Questions regarding the warranty on a specific product and warranty claims should be directed to the Authorized Dealer with whom the purchase transaction was made.

WARRANTY LIMITATIONS: The above warranty does not apply to products that are repaired, modified or altered by any party other than the Authorized Dealer; are subjected to unusual physical stress or conditions (such as overloaded ramps or corrosion), natural disaster, governmental actions, wars, strikes, labor disputes, riots, theft, vandalism, terrorism or any reason beyond reasonable control; are damaged due to improper installation, misuse, abuse, accident or negligence in use, storage, transportation or handling, or tampering; or to products that are considered consumable items or items requiring repair or replacement due to normal wear and tear.

Product should be inspected prior to signing for delivery. Product damage incurred during shipping, unless noted on the Bill of Lading at the time of delivery, renders this warranty void.

LIMITED LIABILITY: In no event shall THE AUTHORIZED DEALER be liable to the purchaser or any third party for any indirect, incidental, consequential, special, exemplary or punitive damages arising out of the use of the product, including, without limitation, property damage, loss of value of the product or any third party products that are used in or with the product, or loss of use of the product or any third party products that are used in or with the product.

