

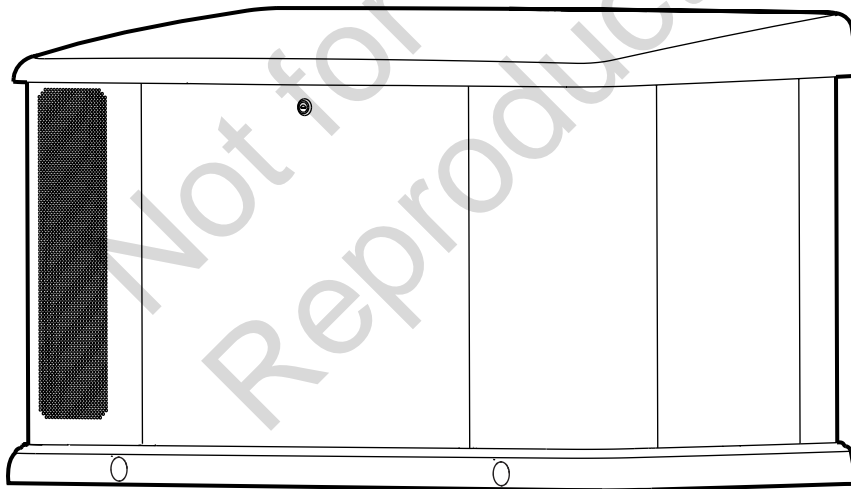

## Installation and Operation Manual

17kW 20kW

Single Phase Air-Cooled Standby Generator System



This generator is rated in accordance with UL (Underwriters Laboratories) 2200 (stationary engine generator assemblies) and CSA (Canadian Standards Association) standard C22.2 No. 100-14 (motors and generators).

# Table of Contents:

<b>California Proposition 65</b> .....	<b>3</b>	Electronic Governing Check.....	33
<b>Thank You</b> .....	<b>3</b>	Service the Spark Plugs.....	34
<b>Where to Find Us</b> .....	<b>3</b>	Engine Air Cleaner.....	34
<b>For Future Reference</b> .....	<b>3</b>	Exhaust System Maintenance.....	35
<b>Important Safety Instructions</b> .....	<b>3</b>	Fuel System Maintenance.....	35
Safety Alert Symbol and Signal Words.....	3	Mixer/Throttle Control Device.....	35
Safety Symbols and Meanings.....	3	Alarms (Service Code Detection System).....	35
Safety Messages.....	4	Acknowledge and Reset the Alarms (Service Code Detection System).....	35
FCC Part 15 Information To User.....	7	Electrical System Maintenance.....	36
<b>General Information</b> .....	<b>8</b>	<b>Troubleshooting</b> .....	<b>38</b>
Equipment Description.....	8	Troubleshooting.....	38
Installer Responsibilities.....	8	<b>Diagrams and Schematics</b> .....	<b>40</b>
Owner Responsibilities.....	8	Wiring Diagram and Schematic.....	40
Installation Factors to Consider.....	8	<b>Specifications</b> .....	<b>41</b>
Delivery Inspection.....	8	Generator Specifications: 17kW and 20KW.....	41
Shipment Contents.....	8	Engine Specifications.....	41
<b>Generator Placement</b> .....	<b>9</b>		
Generator Location Considerations.....	9		
Reduce the Risk of Carbon Monoxide Poisoning.....	9		
Reduce The Risk of Fire.....	11		
Other General Location Guidelines.....	13		
<b>Installation</b> .....	<b>14</b>		
Lifting the Generator.....	14		
Cold Weather Kit.....	14		
Anchoring and Wind Rating.....	14		
Electrical and Fuel Inlet Locations.....	15		
Access Panels.....	15		
Fuel Installation Plan.....	16		
Electrical Field Connections.....	20		
Final Installation Considerations.....	22		
System Control Board.....	23		
Initial Start-Up (No Load).....	24		
<b>Operation</b> .....	<b>26</b>		
Features and Controls - 17kW and 20kW Generators.....	26		
Important Owner's Considerations.....	28		
Automatic Operation Sequence.....	28		
Setting the Exercise Timer.....	28		
<b>Maintenance</b> .....	<b>30</b>		
Servicing the System.....	30		
Maintenance Schedule.....	30		
Generator Maintenance.....	30		
Cleaning the Generator.....	30		
Engine Maintenance.....	31		
Changing Engine Oil and Oil Filter.....	31		
Adjust Valve Lash.....	32		
Electronic Governor System.....	33		

# California Proposition 65



## WARNING

This product can expose you to chemicals including used engine oil, which is known to the State of California to cause cancer, and carbon monoxide, which is known to the State of California to cause birth defects or other reproductive harm. For more information go to [www.P65Warnings.ca.gov](http://www.P65Warnings.ca.gov).

## Thank You

Thank you for purchasing this quality-built Briggs & Stratton® generator. We are pleased that you have placed your confidence in the Briggs & Stratton brand. When operated and maintained according to the instructions in this manual, your generator will provide many years of dependable service.

This manual contains safety information to make you aware of the hazards and risks associated with standby generators and how to avoid them. This product is only for use as an optional generator system which provides an alternate source of electric power and to serve loads such as heating, refrigeration systems, and communication systems that, when stopped during any power outage, could cause discomfort or inconvenience.

**SAVE THESE INSTRUCTIONS** - This manual contains important instructions that must be obeyed during installation, operation, and maintenance of the generator and batteries.

**This generator system requires professional installation before use.** The installer must obey the instructions completely.

## Where to Find Us

You never have to look far to find support and service for your equipment. There are many authorized service dealers worldwide that provide quality service. You can also contact Customer Service by phone at **800-732-2989** between 8:00 AM and 5:00 PM central time or click on Dealer Locator at [www.briggsandstratton.com](http://www.briggsandstratton.com), which provides a list of authorized dealers.

## For Future Reference

Please fill out the information below and keep with your receipt. Have this information at hand if it becomes necessary to contact your installer or authorized dealer regarding service or repair of the unit.

Date of Purchase: \_\_\_\_\_

Dealer / Retailer: \_\_\_\_\_

Dealer's / Retailer's Phone Number: \_\_\_\_\_

### GENERATOR:

Model Number: \_\_\_\_\_

Model Revision: \_\_\_\_\_

Serial Number: \_\_\_\_\_

### ENGINE:

Model Number: \_\_\_\_\_

Serial Number: \_\_\_\_\_

## Important Safety Instructions

Every effort has been made to make sure that the information in this manual is accurate and current. However, we reserve the right to change, or improve the product and this document without notification.

The manufacturer cannot possibly anticipate every possible circumstance that can involve a hazard. The warnings in this manual, and the tags and decals affixed to the unit are, therefore, not all-inclusive. If you use a procedure, work method or operating technique that the manufacturer does not recommend, you must satisfy yourself that it is safe for you and others. You must also make sure that the procedure, work method or operating technique that you choose does not render the equipment unsafe.

## Safety Alert Symbol and Signal Words

The safety alert symbol  identifies safety information about hazards that can result in personal injury. A signal word (**DANGER**, **WARNING**, or **CAUTION**) is used with the alert symbol to indicate the likelihood and the potential severity of injury. In addition, a hazard symbol may be used to represent the type of hazard.



**DANGER** indicates a hazard which, if not avoided, **will** result in death or serious injury.



**WARNING** indicates a hazard which, if not avoided, **could** result in death or serious injury.



**CAUTION** indicates a hazard which, if not avoided, **could** result in minor or moderate injury.

**NOTICE** Indicates information considered important but not hazard-related.

## Safety Symbols and Meanings

Symbol	Meaning
	Safety alert symbol. Indicates a potential personal injury hazard.

Symbol	Meaning
	Read Manual. Failure to obey warnings, instructions, installation manual, and operator's manual could result in death or serious injury.
	Fire
	Explosion
	Electric Shock
	Toxic Fumes
	Moving Parts
	Wear Eye Protection
	Hazardous Chemical
	Hot Surface
	Rotating Parts
	Crush and Cut
	Explosive Pressure

Symbol	Meaning
	Auto Start

## Safety Messages

 **WARNING**

 Failure to read and obey the operator's manual, all warnings, and operating instructions could result in death or serious injury.

 **WARNING**

 Engine exhaust contains carbon monoxide, a poisonous gas that could kill you in minutes. You cannot smell it, see it, or taste it. Even if you do not smell exhaust fumes, you could still be exposed to carbon monoxide gas.

- Operate this product **ONLY** outdoors in an area that will not accumulate deadly exhaust gas.
- Direct exhaust gas away from any windows, doors, ventilation intakes, soffit vents, crawl spaces, open garage doors or other openings that can allow exhaust gas to enter inside or be drawn into a potentially occupied building or structure.
- Carbon monoxide detector(s) **MUST** be installed and maintained indoors according to the manufacturer's instructions/recommendations. Smoke alarms cannot detect carbon monoxide gas.
- If you start to feel sick, dizzy, weak, or your carbon monoxide alarm sounds while using this product, get to fresh air right away. Call emergency services. You may have carbon monoxide poisoning.

 **WARNING**

 Storage batteries give off explosive hydrogen gas during recharging. Slightest spark could ignite hydrogen and cause explosion, resulting in death or serious injury.

- **DO NOT** dispose of battery in a fire. Recycle battery.
- **DO NOT** allow any open flame, spark, heat, or lit cigarette during and for several minutes after charging a battery.

 **WARNING**

 Battery electrolyte fluid contains acid and is extremely caustic. Contact with battery contents could cause severe chemical burns.

- DO NOT open or mutilate the battery
- Wear protective goggles, rubber apron, rubber boots and rubber gloves.
- Immediately wash electrolyte from skin with water.
- If electrolyte contacts eyes, immediately flush with water and seek medical attention.
- Spilled electrolyte is to be washed down with an acid neutralizing agent.

 **WARNING**

 A battery presents a risk of high short circuit current.

- Remove watches, rings, or other metal objects.
- Use tools having insulated handles.
- Disconnect charging source prior to connecting or disconnecting battery terminals.
- Do not lay tools or metal parts on top of batteries.
- Disconnect the negative (-) cable at the battery during installation and maintenance.

 **WARNING**

 Failure to isolate generator from utility power could result in death or serious injury to electric utility workers due to backfeed of electrical energy.

- Use a listed transfer switch to connect to a building electrical system.

 **WARNING**

 Generator and utility voltage could cause electrical shock or burn resulting in death or serious injury.

- Installation must be performed by a licensed professional.
- Disconnect all sources of electricity before installing or servicing equipment.
- Ground system before applying power.

 **WARNING**

 Hazardous Voltage - Installing low and high voltage wire in same conduit could cause electric shock or burns, resulting in death or serious injury.

- Do not run low and high voltage wire in the same conduit unless the insulation rating on ALL wiring is rated for 600V. See NFPA 70 for more information.

 **WARNING**

 Exhaust heat/gases could ignite combustibles or structures resulting in death or serious injury.



- Exhaust outlet of enclosure must have at least 5 ft. (1.5m) minimum clearance from any structure, shrubs, trees, or any kind of vegetation.
- Enclosure must be at least 5 ft (1.5m) from windows, doors, any wall opening, shrubs, or vegetation over 12 inches (30.5 cm) in height.
- Enclosure must have a minimum of 5 ft. (1.5 m) overhead clearance from any structure, overhang, or trees.
- DO NOT place enclosure under a deck or other type of structure that may confine airflow.
- Smoke detector(s) MUST be installed and maintained indoors according to the manufacturer's instructions. Carbon monoxide alarms cannot detect smoke.
- Do not place enclosure in a manner other than shown in illustrations.

 **WARNING**

 Exhaust heat/gases could ignite combustibles causing a fire, resulting in death or serious injury.

- Remove all combustible materials from in and around the generator compartment.

 **WARNING**

  Gaseous vapors are extremely flammable and explosive. Fire or explosion can cause severe burns or death.

- Never start and run the engine with the air cleaner assembly (if equipped) or the air filter (if equipped) removed.

 **WARNING**

 With the battery connected, the generator may crank and start without warning resulting in death or serious injury.

- Do not connect the negative (-) cable at the battery until the installation is complete.

 **WARNING**

 With the battery connected, the generator may crank and start without warning resulting in death or serious injury.

- Before servicing, stop the generator and disconnect the negative (-) cable at the battery.

 **WARNING**

 Hazardous Voltage - Contact with power lines could cause electric shock or burns, resulting in death or serious injury.

- If lifting or hoisting equipment is used, DO NOT contact any power lines.
- DO NOT lift or move generator without assistance.

 **WARNING**

 Propane and Natural Gas are extremely flammable and explosive, which could cause burns, fire or explosion resulting in death or serious injury.

- Installation must be performed by a licensed professional.
- Install the fuel supply system according to NFPA 37 and other applicable fuel-gas codes.
- Before placing the generator into service, the fuel system lines must be properly purged and leak tested.
- NO leakage is permitted.
- DO NOT operate engine if smell of fuel is present.

 **WARNING**

 Propane and Natural Gas are extremely flammable and explosive, which could cause burns, fire or explosion resulting in death or serious injury.

- The generator is equipped with an automatic safety gas fuel shut-off valve.
- DO NOT operate the equipment if the fuel shut-off valve is missing or inoperative.

 **WARNING**

 Propane and Natural Gas are extremely flammable and explosive, which could cause burns, fire or explosion resulting in death or serious injury.

- LP gas is heavier than air and will settle in low areas.
- Natural gas is lighter than air and will collect in high areas.
- The slightest spark could ignite these fuels and cause an explosion.
- DO NOT light a cigarette or smoke.

 **WARNING**

 Propane and Natural Gas are extremely flammable and explosive, which could cause burns, fire or explosion resulting in death or serious injury.

- Inspect the fuel system periodically.
- NO leakage is permitted.
- DO NOT operate engine if smell of fuel is present.

 **WARNING**

 Generator and utility voltage could cause electrical shock or burn resulting in death or serious injury.

- DO NOT allow unqualified persons to operate or service this equipment.

 **WARNING**

Unintentional sparking could cause fire or electric shock resulting in death or serious injury.

**WHEN ADJUSTING OR MAKING REPAIRS TO YOUR GENERATOR**

- Disconnect the spark plug wire from the spark plug and place the wire where it cannot contact spark plug.

**WHEN TESTING FOR ENGINE SPARK**

- Use approved spark plug tester.
- DO NOT check for spark with spark plug removed.

**NOTICE** Improper treatment of generator could damage it and shorten its life.

- Use generator only for intended uses.
- If you have questions about intended use, contact your authorized dealer.
- Operate generator only on level surfaces.
- Adequate, unobstructed flow of cooling and ventilating air is critical to correct generator operation.
- The access panels/doors must be installed whenever the unit is running.
- DO NOT expose generator to excessive moisture, dust, dirt, or corrosive vapors.
- Remain alert at all times while working on this equipment. Never work on the equipment when you are physically or mentally fatigued.
- DO NOT insert any objects through cooling slots.
- DO NOT use the generator or any of its parts as a step. Stepping on the unit could cause stress and break parts. This may result in dangerous operating conditions from leaking exhaust gases, fuel leakage, oil leakage, etc.
- Shut off generator if:
  - electrical output is lost.
  - equipment sparks, smokes, or emits flames.
  - unit vibrates excessively or makes unusual noises.

## FCC Part 15 Information To User

Pursuant to part 15.21 of the FCC Rules, you are cautioned that changes or modifications to the product not expressly approved by Briggs & Stratton could void your authority to operate the product.

This device complies with part 15 of the FCC Rules.

Operation is subject to the following two conditions: (1) This device may not cause harmful interference, and (2) this device must accept any interference received, including interference that may cause undesired operation.

This equipment has been tested and found to comply with the limits for a Class B digital device, pursuant to part 15 of the FCC Rules. These limits are designed to provide reasonable protection against harmful interference in a residential installation. This equipment generates, uses and can radiate radio frequency energy and, if not installed and used in accordance with the instructions, may cause harmful interference to radio communications. However, there is no guarantee that interference will not occur in a particular installation. If this equipment does cause harmful interference to radio or television reception, which can be determined by turning the equipment off and on, the user is encouraged to try to correct the interference by one or more of the following measures:

- Reorient or relocate the receiving antenna.
- Increase the separation between the equipment and receiver.
- Connect the equipment into an outlet on a circuit different from that to which the receiver is connected.
- Consult the dealer or an experienced radio/TV technician for help.

## General Information

For most applications, this manual contains the information necessary for the correct installation, operation, and maintenance of the equipment. All efforts have been made to make sure that the information in this manual is accurate and current. We reserve the right to change the product and this document without notification.

## Equipment Description

**NOTICE** This product does NOT qualify for either an emergency standby or legally required standby system as defined by NFPA 70 (NEC).

- Emergency generator systems are intended to automatically supply illumination, power, or both, to designated areas and equipment in the event of failure of the normal supply. Emergency systems can also provide power for such functions as ventilation where essential to maintain life, where current interruption of the normal supply would produce serious life safety or health hazards.
- Legally Required standby generator systems are intended to automatically supply power to selected loads in the event of failure of the normal source which can create hazards or hamper rescue or fire-fighting operations.

## Installer Responsibilities

- Read and obey the safety instructions.
- Install only a NRTL-approved transfer switch that is compatible with the generator.
- Read and obey the instructions in this Installation and Operation Manual.
- Installation must strictly comply with all applicable codes, industry standards, laws, and regulations.
- Allow sufficient room on all sides of the generator for maintenance and service.
- Discuss the generator placement with owner.
- Make sure that ALL manuals are given to the owner after the installation has been completed.

## Owner Responsibilities

- Read and obey the instructions in this Installation and Operation Manual.
- Follow a regular schedule for maintaining and using the generator, as specified in this manual.
- Carbon monoxide detector(s) MUST be installed and maintained indoors according to the manufacturer's instructions and recommendations. Smoke alarms cannot detect carbon monoxide gas.
- Smoke detector(s) MUST be installed and maintained indoors according to the manufacturer's instructions and recommendations. Carbon monoxide alarms cannot detect smoke.

## Installation Factors to Consider

The illustrations shown in this manual are for typical circumstances. They are meant to familiarize you with the installation options available for the generator.

Federal and local codes, appearance, noise levels, fuel types, and distances are installation factors that must be considered. Remember that, as the distance increases from the existing electrical service and gaseous fuel supply, and the number of bends in the fuel supply increases, compensations must be made for piping and wiring materials. This is necessary to comply with local codes and overcome electrical voltage drops and gaseous fuel pressure drops.

## Delivery Inspection

Avoid damage from dropping, bumping, or collision with the shipping carton.

After removing the carton, carefully inspect the generator for any damage that may have occurred during shipment.

If loss or damage is found at the time of delivery, have the person(s) making the delivery notate the loss or damage on the freight bill and affix his signature under the consignor's memo of loss or damage. If the loss or damage is notated after delivery, separate the damaged materials and then contact the carrier for claim procedures. Missing or damaged parts are not warranted.

## Shipment Contents

The generator system is supplied with:

- Oil (5W30 Synthetic)
- Flexible fuel line
- Quick Operation Manual
- Product and emissions warranty booklet
- Two access keys
- Two 15 Amp ATO-type fuses
- Four lifting hole caps
- Touch up paint

Not included (You will need):

- Carbon monoxide detector(s)
- Smoke detector(s)
- Starting battery
- Connecting wire and conduit
- Fuel supply valves/plumbing
- Crane, lifting straps, chains or cables
- Two 60" (152cm) lengths of 3/4" (1.9cm) nominal minimum Schedule 40 steel pipe (NOT conduit)
- Torque screwdriver, 5 to 50 inch-pound range
- Multi-meter



# Generator Placement

Before installing the generator, consult with the owner and convey the following requirements, which must be satisfied before the installation is complete. There are two equally important safety concerns in regards to carbon monoxide poisoning and fire. There are also several general location guidelines that must be met before the installation is considered complete.



**WARNING**



Engine exhaust contains carbon monoxide, a poisonous gas that could kill you in minutes. You cannot smell it, see it, or taste it. Even if you do not smell exhaust fumes, you could still be exposed to carbon monoxide gas.

- Operate this product **ONLY** outdoors in an area that will not accumulate deadly exhaust gas.
- Direct exhaust gas away from any windows, doors, ventilation intakes, soffit vents, crawl spaces, open garage doors or other openings that can allow exhaust gas to enter inside or be drawn into a potentially occupied building or structure.
- Carbon monoxide detector(s) **MUST** be installed and maintained indoors according to the manufacturer's instructions/recommendations. Smoke alarms cannot detect carbon monoxide gas.
- If you start to feel sick, dizzy, weak, or your carbon monoxide alarm sounds while using this product, get to fresh air right away. Call emergency services. You may have carbon monoxide poisoning.
- **DO NOT** run this product inside homes, garages, basements, crawlspaces, sheds, or other partially-enclosed spaces even if using fans or opening doors and windows for ventilation. Carbon monoxide can quickly build up in these spaces and can linger for hours, even after this product has shut off.
- **ALWAYS** place this product downwind and point the engine exhaust (A) away from occupied spaces.

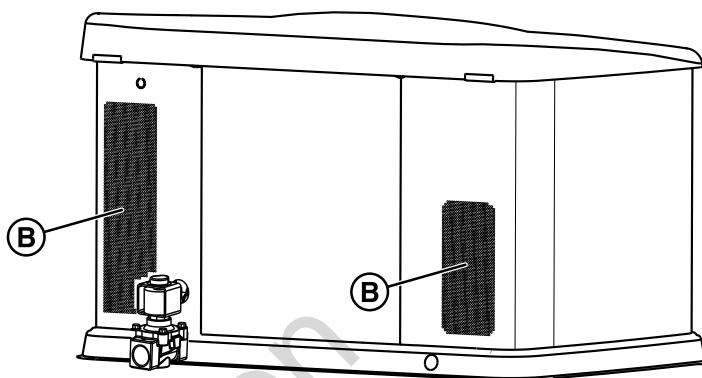
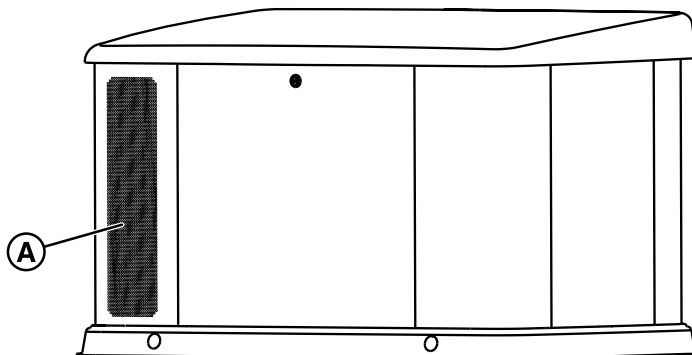

(A) Exhaust outlet side of enclosure.

(B) Air inlet side of enclosure.

## Generator Location Considerations

The installation location of the generator has a direct effect on:

1. The amount and size of the plumbing required to fuel the generator.
2. The amount and size of the wiring required to control and connect the generator.
3. The safety of the installation regarding exhaust gas and carbon monoxide hazards, fire risks, proximity to other utilities, and exposure to weather elements.

Specific location guidelines are discussed in the next section. The owner and installer must consult one another to determine how the site can affect installation costs and compliance with local codes and standards.

There are two critical safety concerns to be addressed - carbon monoxide poisoning and the risk of fire, as follows:

## Reduce the Risk of Carbon Monoxide Poisoning

The arrows in the figure below point to potential points of entry for Carbon Monoxide Gas.

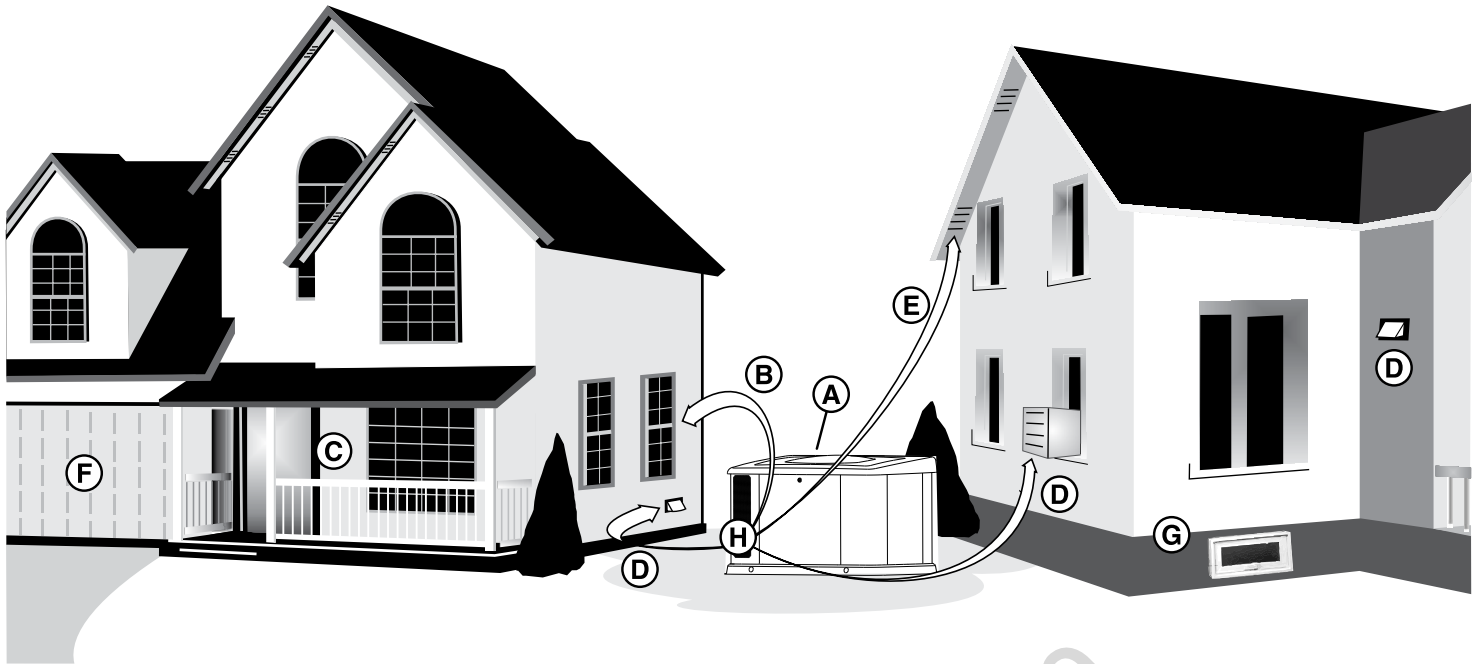

All fossil fuel burning equipment, such as standby generators (A), contains carbon monoxide (CO) gas in the engine exhaust (H). CO gas is odorless, colorless and tasteless and is unlikely to be noticed until a person is overcome. CO gas can kill you so it is required that the following is included as part of the installation.

- Install generator (A) outdoors in an area that will not accumulate deadly exhaust gas (H).
- DO NOT install the generator (A) where exhaust gas (H) can accumulate and enter inside or be drawn into a potentially occupied building or structure.
- In many states it is required by law to have a Carbon Monoxide (CO) detector that works in your home. Carbon monoxide detector(s) MUST be installed and maintained indoors according to the manufacturer's instructions / recommendations. A CO detector is an electronic device that detects hazardous levels of CO. When there is a buildup of CO, the detector will alert the occupants with an alarm and by flashing a visual indicator light. Smoke alarms cannot detect CO gas.
- Your neighbor(s) home can be exposed to the engine exhaust (H) from your standby generator (A) and must be considered when installing your standby generator.
- Make sure exhaust gas (H) is kept away from:

(B) Windows

(C) Doors

(D) Ventilation Intakes

(E) Soffit Vents

(F) Garage Doors

(G) Crawl spaces or other openings that can allow exhaust gas to enter inside or be drawn into a potentially occupied building or structure.

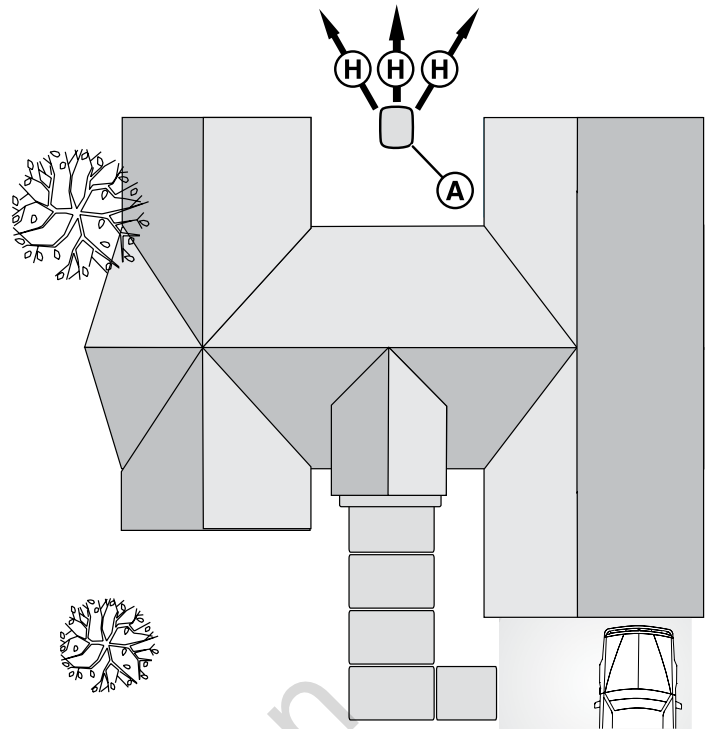
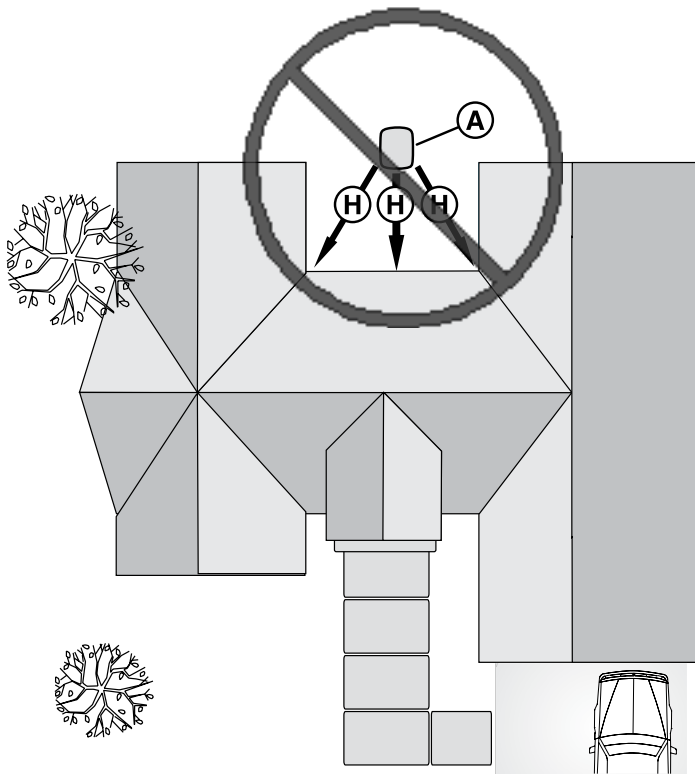

- Nearby structures may be exposed to the engine exhaust (H) from the generator (A) and must be considered when installing the standby generator.
- Wind and air currents should be taken into consideration when positioning the generator (A). Place the generator in an area where winds will carry the exhaust gas (H) away from any potentially occupied building or structure.
- DO NOT place the standby generator (A) in any area where leaves or debris can accumulate.

## Reduce The Risk of Fire

Obey the installation requirements listed below. The figures below illustrate the minimum distances from structures and vegetation to reduce the risk of fire.

The National Fire Protection Association (NFPA) standard NFPA 37 establishes criteria for minimizing the hazard of fire during the installation and operation of stationary combustion engines. NFPA 37 limits the spacing of an enclosed generator from openings in walls, structures and combustible materials outside the enclosure. The following generator placement requirements are based on compliance to NFPA 37.

### WARNING

 Exhaust heat/gases could ignite combustibles or structures resulting in death or serious injury.

- Exhaust outlet of enclosure must have at least 5 ft. (1.5m) minimum clearance from any structure, shrubs, trees, or any kind of vegetation.
- Enclosure must be at least 5 ft (1.5m) from windows, doors, any wall opening, shrubs, or vegetation over 12 inches (30.5 cm) in height.
- Enclosure must have a minimum of 5 ft. (1.5 m) overhead clearance from any structure, overhang, or trees.
- DO NOT place enclosure under a deck or other type of structure that may confine airflow.
- Smoke detector(s) MUST be installed and maintained indoors according to the manufacturer's instructions. Carbon monoxide alarms cannot detect smoke.
- Do not place enclosure in a manner other than shown in illustrations.

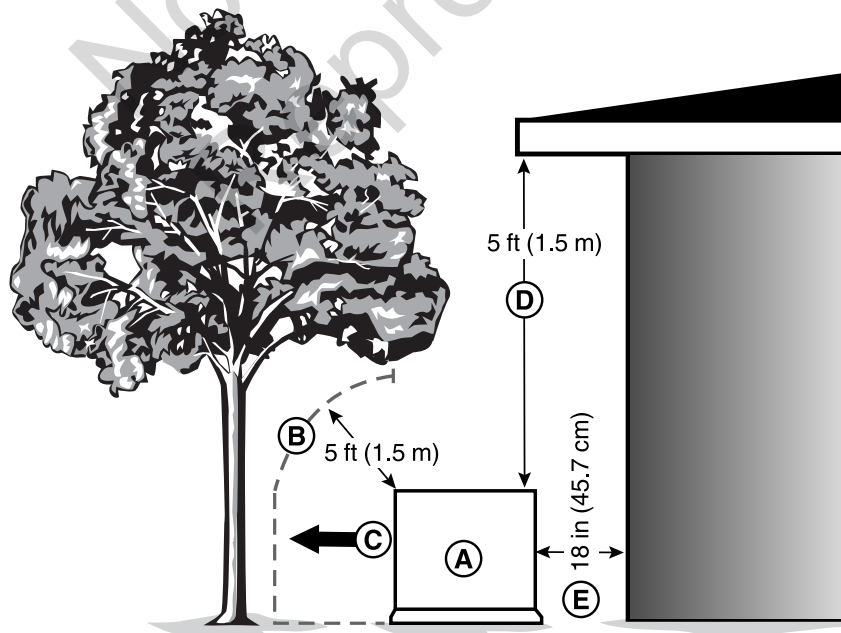
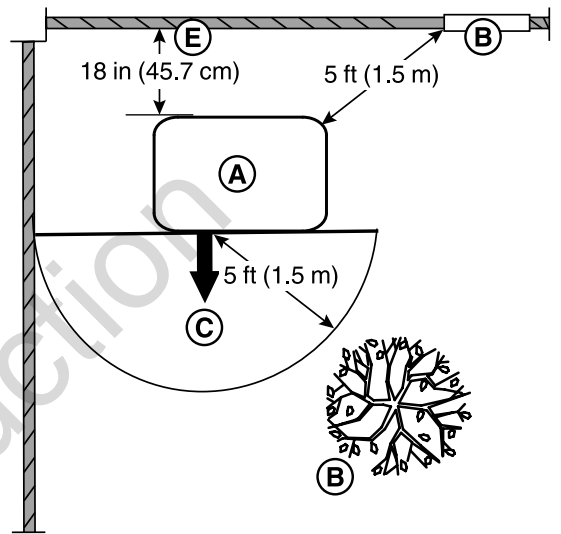
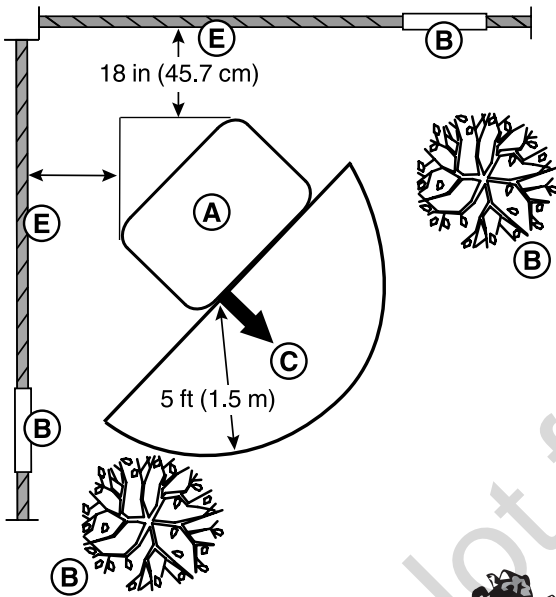
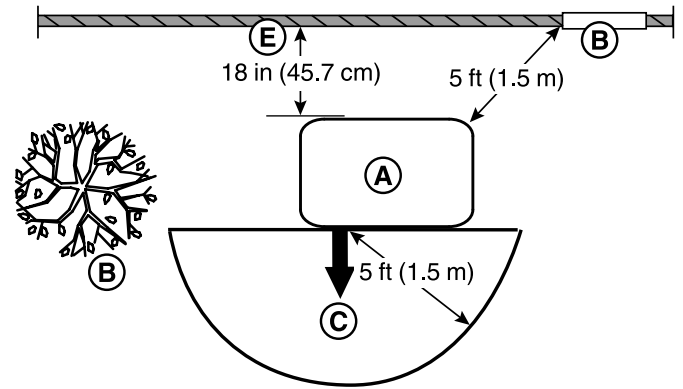
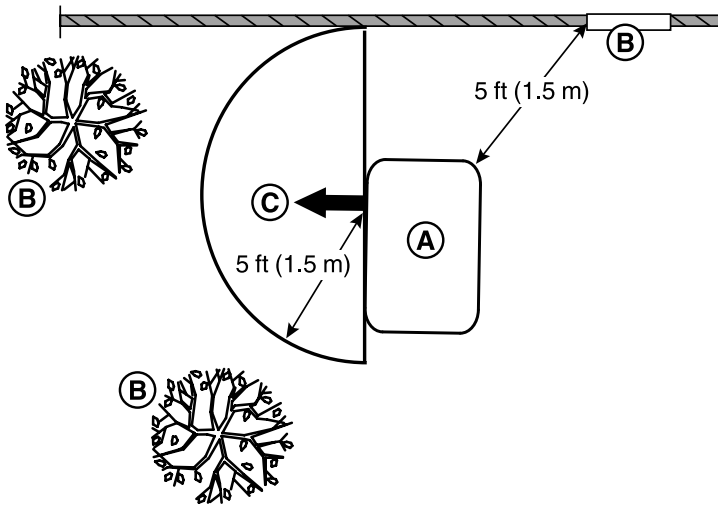

Legend for Generator Locations to reduce the risk of fire:

(A) Standby Generator

- (B) Standby enclosure must be at least 5 ft (1.5 m) from windows, doors, any wall opening, shrubs or vegetation over 12 inches (30.5 cm) in height.
- (C) Exhaust outlet of standby enclosure must have at least 5 ft (1.5 m) minimum clearance from any structure, shrubs, trees or any kind of vegetation.
- (D) Standby enclosure must have a minimum of 5 feet (1.5 m) overhead clearance from any structure, overhang or trees.
- (E) Standby enclosure must have a minimum of 18 inches (45.7 cm) clearance from any structures with or without a fire rating.

## Other General Location Guidelines

- Place the standby generator in a prepared location that is flat and has provisions for water drainage.
- Install the standby generator in a location where sump pump discharge, rain gutter down spouts, roof run-off, landscape irrigation, or water sprinklers will not flood the unit or spray the enclosure and enter any air inlet or outlet openings.
- Install the standby generator where it will not affect or obstruct any services (including covered, concealed and underground), such as telephone, electric, fuel (natural gas / LPG vapor), irrigation, air conditioning, cable, septic, sewer, well and so forth.
- Install the standby generator where leaves, grass, snow, etc will not obstruct air inlet and outlet openings. If prevailing winds will cause blowing or drifting, you may need to construct a windbreak to protect the unit.

Not for  
Reproduction

## Installation

This product is only for use as an optional generator system which provides an alternate source of electric power and to serve loads such as heating, refrigeration, and communication systems that, when stopped during any power outage, can cause discomfort or inconvenience.

Every effort has been made to make sure that the information in this manual is accurate and current. However, we reserve the right to change, alter, or otherwise improve the product and this document at any time without prior notice.

Only current licensed electrical and plumbing professionals can attempt generator system installations. Installations must strictly comply with all applicable codes, industry standards, laws and regulations.

## Lifting the Generator



### WARNING



Hazardous Voltage - Contact with power lines could cause electric shock or burns, resulting in death or serious injury.

- If lifting or hoisting equipment is used, DO NOT contact any power lines.
- DO NOT lift or move generator without assistance.

Proper tools, equipment, and qualified personnel must be used in all phases of handling and moving the generator. The approximate weight of the generator is listed in the *Generator Specifications* section.

Use the lifting holes (A) in the base of the generator to lift the generator onto the concrete pad. Lift the generator in accordance with OSHA or local lifting regulations. Retouch any chipped paint with the supplied touch-up paint.

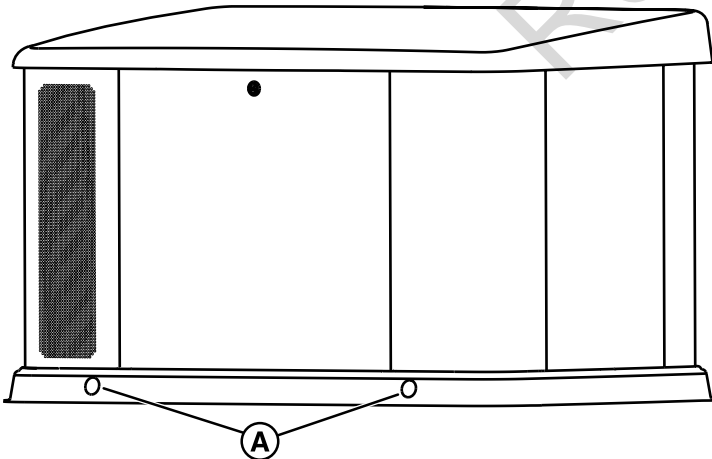

## Cold Weather Kit

If the generator operates in temperatures below 30°F (-1°C), it is HIGHLY RECOMMENDED that a Cold Weather Kit be installed.

Cold Weather Kit, Part No. 6578 (Fortress models) includes:

- Battery warmer
- Battery stand

Cold Weather Kit, Part No. 6567 (Briggs & Stratton models) includes:

- Oil warmer
- Battery warmer
- Battery stand
- Wire harness

These items are available at your local service dealer.

If you need more information, please call **800-732-2989** between 8:00 AM and 5:00 PM CT.

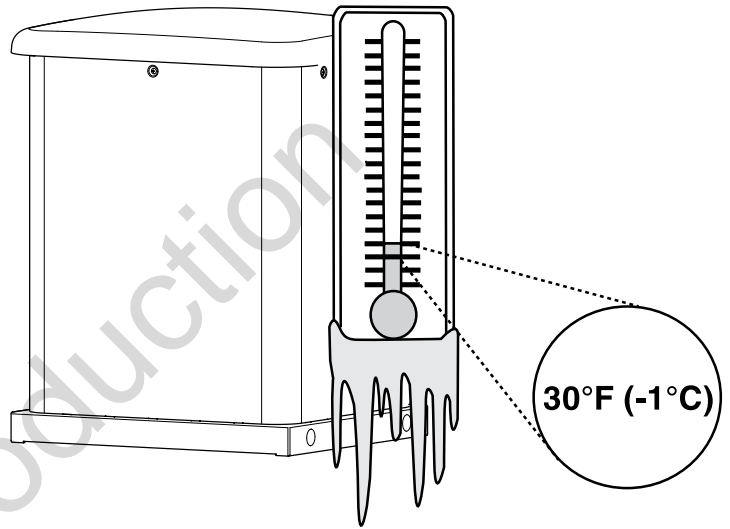

## Anchoring and Wind Rating

### Concrete Anchoring of Unit to Poured or Existing Slab

To achieve the listed wind rating, the generator must be installed in strict compliance with this installation manual. The product components must be of the material specified and all screws must be installed in accordance with the applicable provisions and the anchor manufacturer's published installation instructions.

The concrete slab/pad must meet the requirements below and the generator must be anchored with the anchors of **Anchor Types 1 or 2**.

### Anchor Types

1. Qty (4) 3/8" SS ITW RED HEAD LDT, Anchor embedded 2 1/2" (63.5mm) in 3000 psi concrete. 3" (76.2mm) from the edge minimum, 6" (152.4mm) spacing minimum.

2. Qty (4) 3/8" SS Powers/Dewalt Power Stud +SD2 Anchor embedded 2 1/2" (63.5mm) in 3000 psi concrete. 3" (76.2mm) from the edge minimum, 6" (152.4mm) spacing minimum.

There are four 7/16" hole locations (A) in the base of the generator in which to anchor the unit.

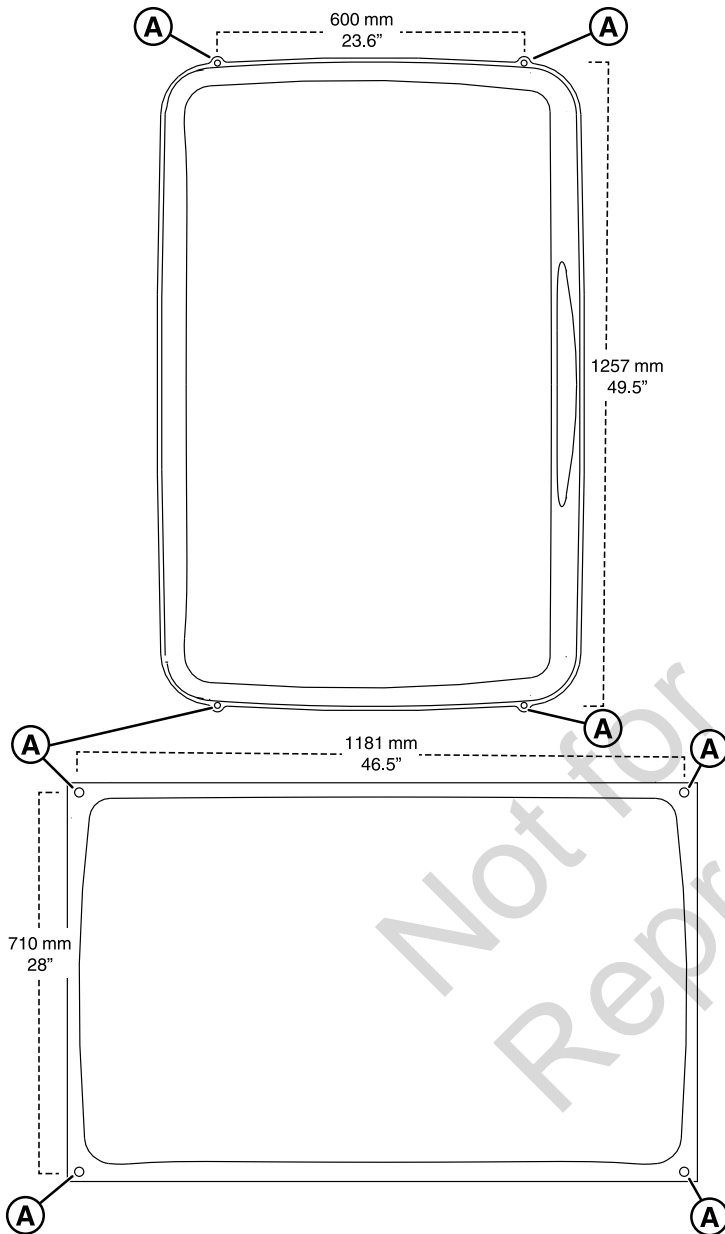

140 to 175	Poured	38in (965.2mm)	55in (1397mm)	5in (127mm)	3000 PSI
------------	--------	-------------------	------------------	----------------	----------

These items are available at your local service dealer.

**NOTICE** Unless mandated by local or state codes, or required to achieve wind rating, a concrete slab/pad is not required

## Electrical and Fuel Inlet Locations

The 3/4 inch N.P.T. fuel inlet connector (A) and electrical inlet locations (B) are shown below.

A 1/2 inch knock-out is provided for the electrical inlet. This inlet may be enlarged or supplemented to accommodate a maximum conduit size of 1-1/2 inches. Make sure that the installed conduit(s) enter the unit in zone (C) as shown in the drawing below so that they properly enter the electrical box and do not interfere with the fully opened roof.

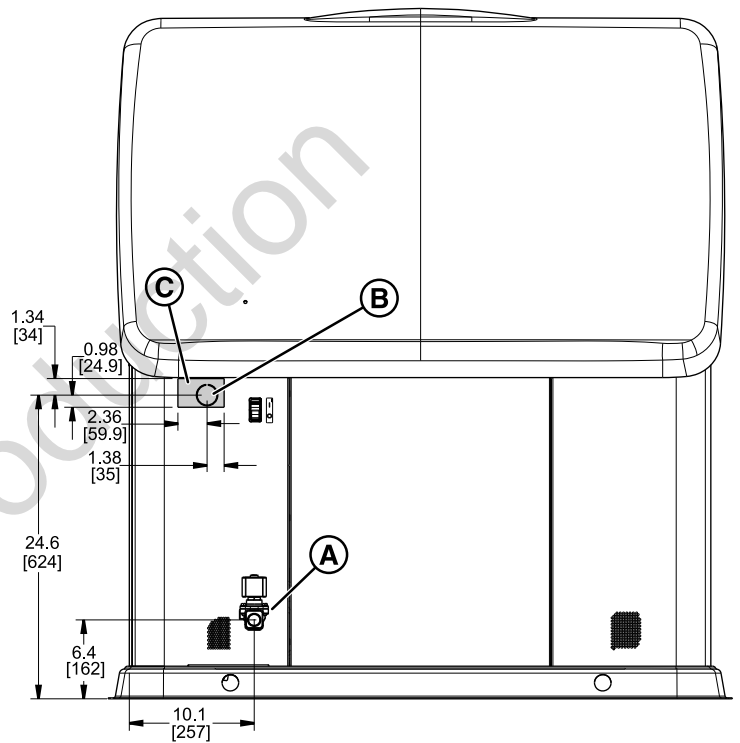

## Concrete Slab/Pad Types

WIND RATING MPH	PAD MODEL	PAD DIMENSIONS			CONCRETE SPEC
		Width	Length	Thickness	
Up to 140	Pre-cast Pad (contact dealer)	37in (939.8mm)	54.4in (1381.8mm)	3in (76.2mm)	3000 PSI
140 to 175	Pre-cast Pad (contact dealer)	37in (939.8mm)	54.4in (1381.8mm)	4in (101.6mm)	3000 PSI

## Access Panels

The generator enclosure has several access panels, as shown.

The access panels and the components located behind them are listed below:

- (A) Roof (Control Panel, air filter, oil dipstick, and circuit breaker)
- (C) Rear Access Panel (fuel regulator, fuel selector, and engine starter)
- (D) Control Panel Cover (field wiring and control wires)
- (F) Battery Panel (battery and generator data label)
- (H) Front Access Panel (oil drain and oil filter)

Each generator is shipped with a set of identical keys fastened to the fuel solenoid.

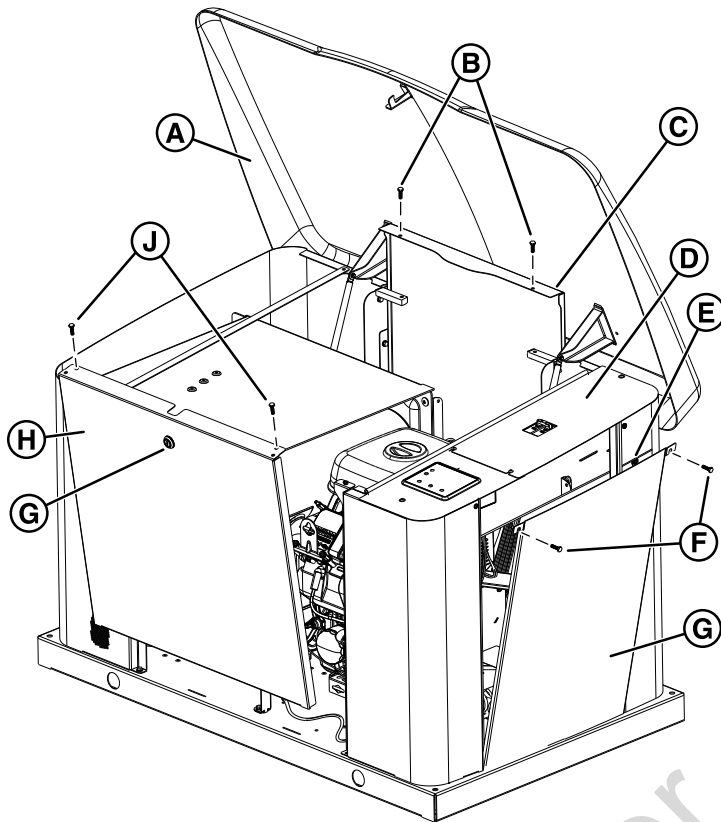

#### Open the roof (A):

1. Insert key into lock (G) of front panel (H). Gently push down on the roof above the lock to assist in turning the key. Turn the key one quarter turn clockwise.
2. Lift the roof (A) to the open position.

#### Front panel removal (H):

1. Remove the two bolts (J) that secure the panel (H) to the unit.
2. Lift the panel (H) to remove from unit.

#### Attach the front panel (H):

1. Put the panel (H) in the unit.
2. Attach the panel (H) with the two bolts (J).

#### Rear panel removal (C):

1. Make sure that the roof (A) is in the open position.
2. Remove the two bolts (B) that secure the panel (C) to the unit.
3. Lift the panel (C) to remove it from the unit.

#### Attach the rear panel (C):

1. Slide the panel (C) into place on the unit.
2. Attach the panel with the two bolts (B).

#### Battery panel removal (G):

1. Make sure that the roof is in the open position.
  2. Remove the two bolts (F) that secure the panel (G) to the unit.
  3. Lift up on the panel (G) and remove it.
- Note:* Fuse holder (E) is located behind the battery panel (G).

#### Attach battery panel (G):

1. Put the panel (G) in the unit.
2. Attach the panel (G) with the two bolts (F).

## Fuel Installation Plan



### WARNING



Propane and Natural Gas are extremely flammable and explosive, which could cause burns, fire or explosion resulting in death or serious injury.

- Installation must be performed by a licensed professional.
- Install the fuel supply system according to NFPA 37 and other applicable fuel-gas codes.
- Before placing the generator into service, the fuel system lines must be properly purged and leak tested.
- NO leakage is permitted.
- DO NOT operate engine if smell of fuel is present.

**NOTICE** The supplied flexible fuel line is not to be installed underground or in contact with the ground.

- *The entire flexible fuel line must be visible for periodic inspection and must not be concealed within nor contact nor run through any wall, floor, or partition.*

**The information below is provided to assist gaseous fuel system technicians in planning installations. In no way should this information be interpreted to conflict with applicable fuel gas codes. Consult with your local fuel supplier or Fire Marshall if questions or problems arise.**



### WARNING



Propane and Natural Gas are extremely flammable and explosive, which could cause burns, fire or explosion resulting in death or serious injury.

- The generator is equipped with an automatic safety gas fuel shut-off valve.
- DO NOT operate the equipment if the fuel shut-off valve is missing or inoperative.



**WARNING**

Propane and Natural Gas are extremely flammable and explosive, which could cause burns, fire or explosion resulting in death or serious injury.

- LP gas is heavier than air and will settle in low areas.
- Natural gas is lighter than air and will collect in high areas.
- The slightest spark could ignite these fuels and cause an explosion.
- DO NOT light a cigarette or smoke.

**TO THE INSTALLER:** Consult with the generator owner(s) and convey any technical considerations that can affect their installation plans before applying these general guidelines.

The following general rules apply to gaseous fuel system piping:

- The piping material must conform to federal and local codes, be rigidly mounted, and be protected against vibration.
- Piping should be protected from physical damage, especially where it passes through flower beds, shrub beds, and other cultivated areas where damage can occur.
- Install the provided flexible fuel line (B) between the generator fuel inlet port (A) and the rigid piping to prevent thermal expansion and contraction from causing excessive stress on the piping material.
- A union (C) or a flanged connection must be provided downstream to permit removal.
- A manometer test port (D) should be installed for vapor fuels. Use the port to install a manometer and check if the engine receives the correct fuel pressure for operation. A digital manometer (P/N 19495) or an analog manometer is available at your service center for vapor fuels only. When the initial test runs are completed, the manometer is removed and the port is plugged.
- For vapor fuels only: Where the formation of hydrates or ice is known to occur, piping should be protected against freezing. The termination of hard piping must include a sediment trap (E) where condensate is not likely to freeze.
- A minimum of one accessible, approved manual shutoff valve (F) shall be installed in the fuel supply line within 6 ft (180 cm) of the generator.
- You must install a manual fuel shut-off valve in the interior of the building.
- Where local conditions include earthquake, tornado, unstable ground, or flood hazards, special consideration shall be given to increase strength and flexibility of piping supports and connections.
- Piping must be of the correct size to maintain the required supply pressures and volume flow under varying generator load conditions with all gas appliances connected to the fuel system turned on and operating.

- Use a pipe sealant or joint compound approved for use with NG/LP on all threaded fittings to reduce the possibility of leakage.

**NOTICE** Keep thread sealant out of the gas piping to prevent component part damage.

- Installed piping must be properly purged and leak tested, in accordance with applicable codes and standards.

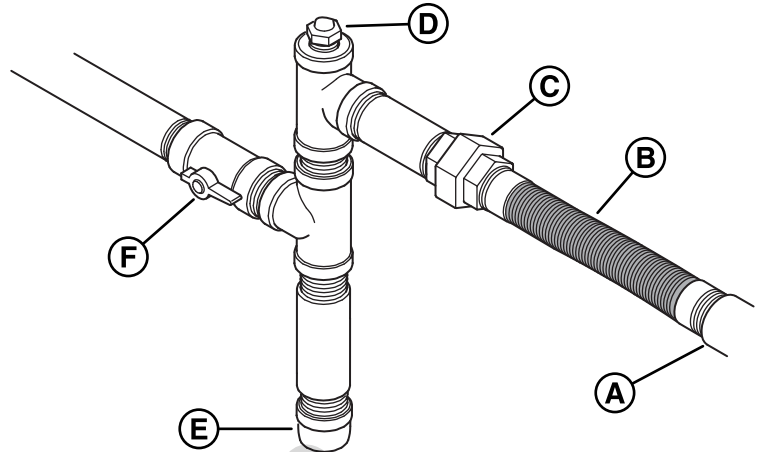

- (A) Generator Fuel Inlet
- (B) Flexible Fuel Line
- (C) Union Fitting
- (D) Manometer Test Port
- (E) Sediment Trap
- (F) Manual Shut-off Valve

**Fuel Consumption**

Estimated fuel supply requirements at half and full load for natural gas and LP vapor fuels are shown below.

**LP Vapor (Propane)**

		20 kW	17 kW
Full Load	Cu Ft/Hr	135	118
	Gal/Hr (liquid)	3.75	3.28
	BTU/Hr	337500	295000
3/4 Load	Cu Ft/Hr	109	99
	Gal/Hr (liquid)	3.03	2.75
	BTU/Hr	272500	247500
1/2 Load	Cu Ft/Hr	83	74
	Gal/Hr (liquid)	2.31	2.06
	BTU/Hr	207500	185000
1/4 Load	Cu Ft/Hr	56	54
	Gal/Hr (liquid)	1.56	1.5
	BTU/Hr	140000	135000
Exercise	Cu Ft/Hr	40	40
	Gal/Hr (liquid)	1.11	1.11
	BTU/Hr	100000	100000

**Natural Gas**

		20 kW (18 kW)	17 kW 15.3 kW
Full Load	Cu Ft/Hr	260	248
	BTU/Hr	260000	248000
3/4 Load	Cu Ft/Hr	240	218
	BTU/Hr	240000	218000
1/2 Load	Cu Ft/Hr	187	170
	BTU/Hr	187000	170000
1/4 Load	Cu Ft/Hr	135	128
	BTU/Hr	135000	128000
Exercise	Cu Ft/Hr	99	99
	BTU/Hr	99000	99000

Recommended Energy Content of Fuel Heating Value:	LP Vapor	Natural Gas
Heating Value:		
BTU per gallon (gross**)	91,547	
Cubic feet (gas)	2,500	1,000

## Fuel Type

An important consideration affecting the entire installation is the type of fuel used by your generator. The system was factory tested and adjusted using natural gas, but can be converted to use LP vapor. For correct engine function, factors that are inherent to each of these fuels, like your location and the duration of possible utility interruptions, are important considerations in the following fuel guidelines:

- Use clean, dry fuel that is free of moisture or any particulate material. Using fuels outside the recommendation values that follow can cause performance problems.
- In engines set up to run on propane (LP), commercial grade HD5 propane with a minimum fuel energy of 2500 BTUs/ft<sup>3</sup> with maximum propylene content of 5% and butane and heavier gas content of 2.5% and minimum propane content of 90% is required.

Natural gas rating will depend on specific fuel, but typical derates are between 10 and 20% of the LP gas rating.

Natural gas or LP engines are certified to operate on natural or liquid propane gas. The emissions control system for this engine is EM (Engine Modifications).

## Fuel Pressure

Both LP vapor and natural gas fuel supply pressure at the generator's fuel inlet port and must be between the following levels at full load with all gas appliances turned on and in operation.

- NG is 3.5-7" W.C.
- LP is 11-14" W.C.

Make sure that all gas line shutoff valves are OPEN and that adequate fuel pressure is available whenever automatic operation is desired.

For Natural Gas fuel pressure levels of 3.5 - 5" W.C., replace the regulator assembly with service kit 6331-00 (available at your local service dealer).

## Power Loss

Air density is less at high altitudes, resulting in less available engine power. Engine power will decrease by 3.5% for each 1,000 feet (300 m) above sea level and by 1% for each 10° F (5.6°C) above 77°F (25°C). Generators located in these conditions must have their transfer switch adjusted appropriately for this power decrease. See your Automatic Transfer Switch manual on how to adjust for the power decrease.

## The Gaseous Fuel System

### Fuel Pipe Sizing

NFPA 54 and 58 are common resources. The installer must consider the specific gravity of gas, compensate for a nominal amount of restriction from bends and fittings, and refer to federal and local codes for guidance.

### Fuel Conversion

The engine of your home generator system is factory Calibrated and set to operate on natural gas (NG). It may also be operated on liquefied petroleum (LP) vapor.

**NOTICE** Units are set to NG at the factory.

To convert to either fuel, follow these steps:

1. Put the key into the lock of the front panel. Lightly push down on the roof above the lock, and then turn the key one quarter turn clockwise.
2. Lift the roof to the open position.
3. Push the control panel OFF button.
4. Remove the battery panel.
5. Remove the 15 Amp fuse.
6. Remove utility power to generator to de-energize the battery charger.
7. Disconnect the negative (-) cable at the battery.
8. Remove the rear panel.
9. Find the fuel selector switch (A) on top of the fuel regulator (B).

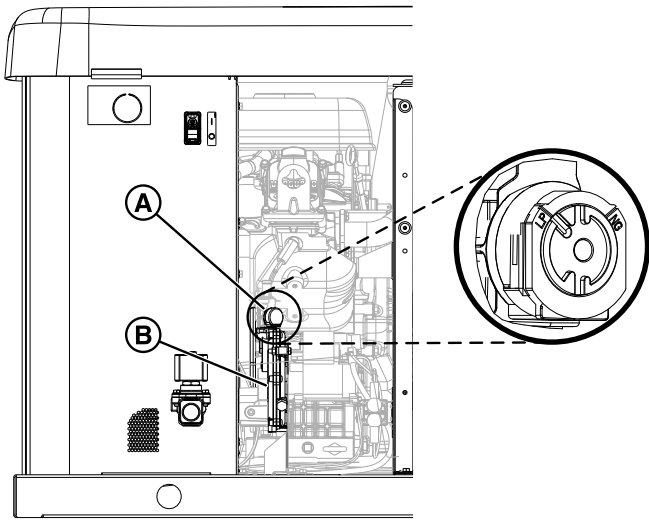

10. Set Fuel Selector:

- A. Remove cap (C) from the Fuel Select Valve by sliding it upward.

*Note:* If this is the first installation of this generator, the cap will be found in the parts bag.

- B. LP or NG is selected by using the cap (C) as a tool to rotate the indicator to the LP or NG mark (the image below shows the FSV set to LP fuel).

- C. Install the cap (C) after fuel selection is complete.

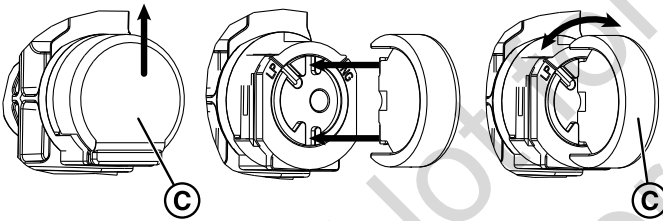

- 11. Once the fuel selection is complete, apply a drop of cyanoacrylate (super) glue on the Fuel Select Cap.
- 12. Connect the negative (-) cable at the battery.
- 13. Install the rear panel.
- 14. Install 15-amp fuse.
- 15. Install the battery panel.
- 16. Push and hold the CONFIG button to access the configuration menu.
- 17. Push SELECT to edit the items in the configuration menu.
- 18. To setup the generators control board for LP fuel you will need to enter the Configuration Menu by using the Dealer Password, which is available on the Power Portal.
- 19. Navigate to "SELECT PROFILE" and press select on the correct profile for the generator. For example "20KW\_LP" for operating a 20kW unit running on LP fuel.

*Note:* Selecting a profile that is not intended for the generator can cause the generator to run erratically and could result in damage.

- 20. To Save the new fuel setting, press and hold the STOP/ CONFIG button until "Saving Settings..." is displayed.
- 21. For Additional information on the operation of the generator controller please refer to the "Operation Instructions GC1031 GENSET Controller Manual," PN: 80086364.
- 22. Close the roof.
- 23. Restore utility power to generator.
- 24. Push the control board AUTO button.

## Fuel Consumption

### LP Vapor (Propane)

		20kW	17kW
<b>Full Load</b>	Cu Ft/Hr	135	118
	Gal/Hr (liquid)	3.75	3.28
	BTU/Hr	337,500	295,000
<b>3/4 Load</b>	Cu Ft/Hr	109	99
	Gal/Hr (liquid)	3.03	2.75
	BTU/Hr	272,500	247,500
<b>1/2 Load</b>	Cu Ft/Hr	83	74
	Gal/Hr (liquid)	2.31	2.06
	BTU/Hr	207,500	185,000
<b>1/4 Load</b>	Cu Ft/Hr	56	54
	Gal/Hr (liquid)	1.56	1.5
	BTU/Hr	140,000	135,000
<b>No Load</b>	Cu Ft/Hr	40	40
	Gal/Hr (liquid)	1.11	1.11
	BTU/Hr	100,000	100,000

### Natural Gas

		20kW	17kW
<b>Full Load</b>	Cu Ft/Hr	260	248
	BTU/Hr	260,000	248,000
<b>3/4 Load</b>	Cu Ft/Hr	240	218
	BTU/Hr	240,000	218,000
<b>1/2 Load</b>	Cu Ft/Hr	187	170
	BTU/Hr	187,000	170,000
<b>1/4 Load</b>	Cu Ft/Hr	135	128
	BTU/Hr	135,000	128,000
<b>No Load</b>	Cu Ft/Hr	99	99
	BTU/Hr	99,000	99,000

Recommended Energy Content of Fuel:	Natural Gas	Propane (LP Vapor)
Heating Value: BTU per gallon liquid (gross*)	N/A	91,547
Heating Value: BTU per Cubic feet (vapor)	1,000	2,500

# Electrical Field Connections



**WARNING**



Generator and utility voltage could cause electrical shock or burn resulting in death or serious injury.

- Installation must be performed by a licensed professional.
- Disconnect all sources of electricity before installing or servicing equipment.
- Ground system before applying power.



**WARNING**



Hazardous Voltage - Installing low and high voltage wire in same conduit could cause electric shock or burns, resulting in death or serious injury.

- Do not run low and high voltage wire in the same conduit unless the insulation rating on ALL wiring is rated for 600V. See NFPA 70 for more information.

Low Voltage connections are made via a field connections terminal block (E) in main electrical area. Compare this illustration with your generator to familiarize yourself with the location of these connections.

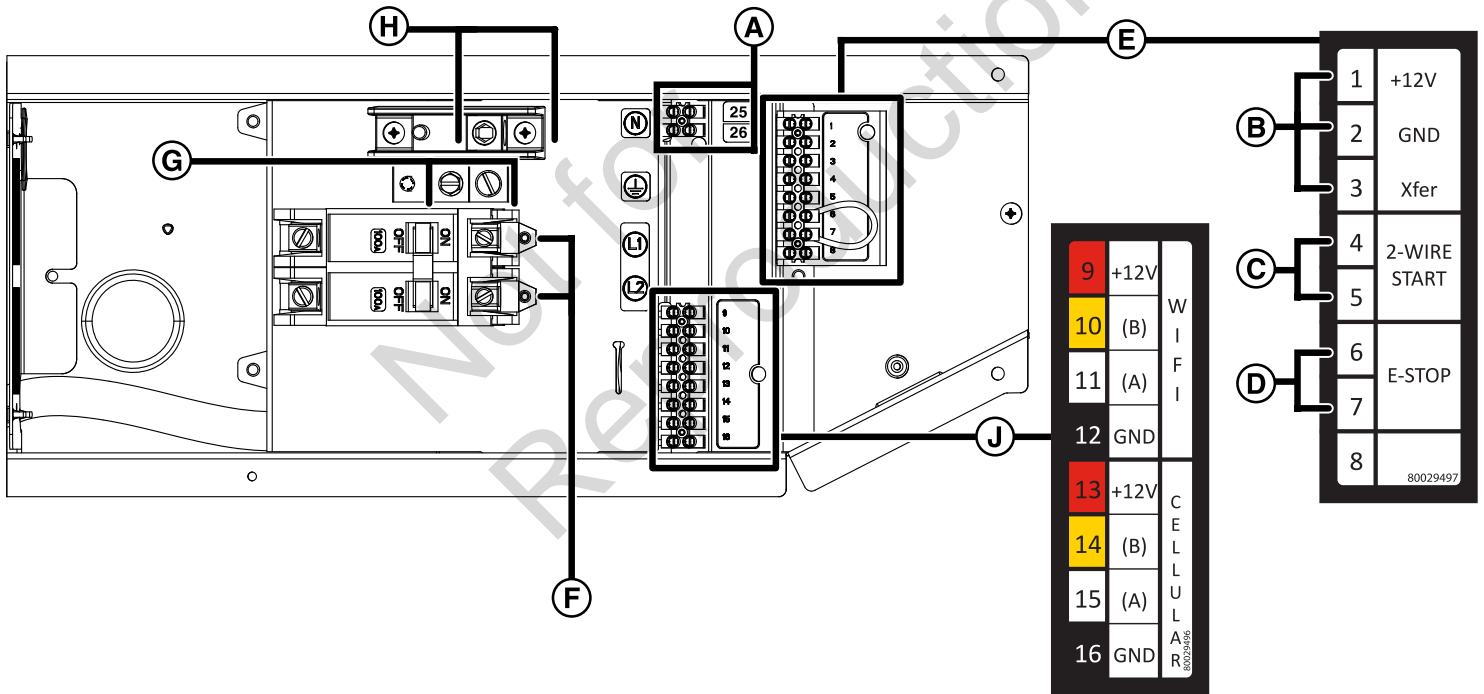

## Legend for System Connector Location

(A) Two Pin Terminal Block — Used to connect utility 240 VAC from fuse block in ATS to the control board. Connect only one wire per terminal. Use #14 [2.5mm<sup>2</sup>] AWG minimum 300 volt wire.

(B) Transfer Switch Connection — Controls Briggs & Stratton<sup>®</sup> transfer switch.

(C) 2-wire start — Used for optional remote start contact.

(D) E-Stop — For use with optional external E-stop.

(E) Field Connections Terminal Block — Reference the table that follows.

(F) Power Connection (L1 and L2) — Power connection to transfer switch.

(G) Ground Connection — Connect to transfer switch ground wire.

(H) Neutral Connection — Connect to transfer switch neutral wire.

(J) Communications Terminal Block — Reference the table that follows.

Pin Number	Description	Wire type	Connect To	Notes
1	12VDC	18AWG[1mm <sup>2</sup> ] conductors, 300V minimum, 90°C Cu wire.	Transfer switch basic controller J7-8 12VDC	Transfer switch Transfer Signal (only works with basic Transfer Switch Controller).
2	GND	18AWG[1mm <sup>2</sup> ] conductors, 300V minimum, 90°C Cu wire.	Transfer switch basic controller J7-7 GND	
3	Transfer Signal	18AWG[1mm <sup>2</sup> ] conductors, 300V minimum, 90°C Cu wire.	Transfer switch basic controller J7-4 T/R	
4	2 Wire-Start	18AWG[1mm <sup>2</sup> ] conductors, 300V minimum, 90°C Cu wire.	Refer to Transfer switch manual to verify if this function is available.	Contact Close for Genset Start. <b>(Only for transfer switch that provides this option)</b>  Mains monitoring must be disabled in the controller.
5	2 Wire-Start	18AWG[1mm <sup>2</sup> ] conductors, 300V minimum, 90°C Cu wire.		
6	E-Stop	18AWG[1mm <sup>2</sup> ] conductors, 300V minimum, 90°C Cu wire.	E-Stop Switch	Contact Open to Shutdown Genset
7	E-Stop	18AWG[1mm <sup>2</sup> ] conductors, 300V minimum, 90°C Cu wire.	E-Stop Switch	
8	Not Used			
9	12VDC	18AWG[1mm <sup>2</sup> ] conductors, 300V minimum, 90°C Cu wire.	Refer to the Amplify Gateway Manual.	Comm to WIFI module  Twisted pair #1: +12V and GND  Twisted pair #2: (A) and (B)
10	(B)	18AWG[1mm <sup>2</sup> ] conductors, 300V minimum, 90°C Cu wire.		
11	(A)	18AWG[1mm <sup>2</sup> ] conductors, 300V minimum, 90°C Cu wire.		
12	GND	18AWG[1mm <sup>2</sup> ] conductors, 300V minimum, 90°C Cu wire.		
13	12VDC	18AWG[1mm <sup>2</sup> ] conductors, 300V minimum, 90°C Cu wire.	Refer to the InfoHub™ Premium Manual.	Comm to Cellular module  Twisted pair #1: +12V and GND  Twisted pair #2: (A) and (B)
14	(B)	18AWG[1mm <sup>2</sup> ] conductors, 300V minimum, 90°C Cu wire.		
15	(A)	18AWG[1mm <sup>2</sup> ] conductors, 300V minimum, 90°C Cu wire.		
16	GND	18AWG[1mm <sup>2</sup> ] conductors, 300V minimum, 90°C Cu wire.		
25	Utility	14AWG [2.5mm <sup>2</sup> ] 300V minimum, 90°C Cu Wire	Transfer switch Utility	Voltage Sensing for Genset Start. Use either this signal or 2-wire start signal for Genset Start Signal.
26	Utility	14AWG [2.5mm <sup>2</sup> ] 300V minimum, 90°C Cu Wire	Transfer switch Utility	

- For power output connection (L1, L2, Neutral (N), and Ground), refer to the National Electric and local codes.
- For communication wires use #18 AWG [1mm<sup>2</sup>] twisted pair conductors, no greater than 500 ft in length, 300 volt wire.
- When connecting to the terminal block, fasten only one wire to each connector screw.
- Torque terminal block screws to 4.4 in-lb [0.49 Newton meter].
- Torque circuit breaker connections to 45 in-lb [5 Newton meter].

## Generator AC System Connection

A single-phase, three-wire AC connection system is used in the generator. The stator assembly consists of a pair of stationary windings with two leads brought out of each winding. The junction of leads 22 and 33 forms the neutral lead, as shown schematically and as a wiring diagram.

**NOTICE** Generator must be used with only an UL approved transfer switch that is compatible with the generator.

**NOTICE** Neutral is not bonded to ground at generator.

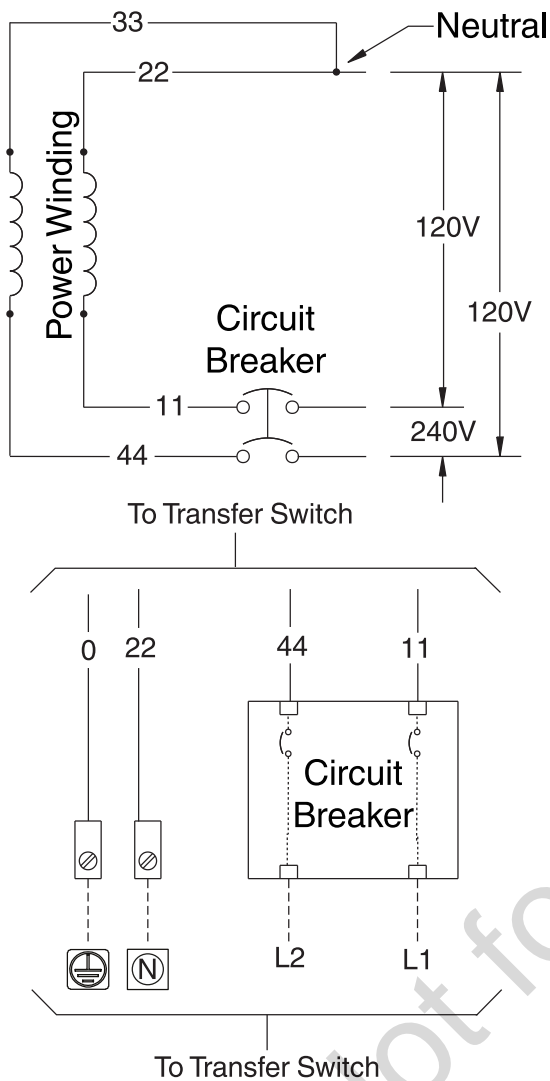

## Grounding the Generator

Unless mandated by local code, additional chassis grounding to earth at the generator is not required. Any grounding at generator must use metal piercing lock washers (or equal), listed terminals installed per terminal supplier's instructions, and comply with national electrical codes and local requirements.

## Power Connections from the Generator to the Transfer Switch



**WARNING**



Failure to isolate generator from utility power could result in death or serious injury to electric utility workers due to backfeed of electrical energy.

- Use a listed transfer switch to connect to a building electrical system.

## Utility Circuit Connection

240V Utility leads must be routed in conduit. The 240V Utility leads deliver power to the generator's circuit board, optional battery warmer and optional oil warmer. This power also charges the battery. In AUTO Mode, when the power on these leads is lost, the generator will start. Using the installer-supplied minimum 300V, 14 [2.5 mm<sup>2</sup>] AWG wire, connect each control circuit terminal in the generator (25 and 26) to the fuse block in the automatic transfer switch.

## Generator Power Connection

Using the installer supplied minimum 300V wires and the table located in the *Electrical Field Connections* section, connect generator power output L1, L2, neutral (N), and ground to the corresponding L1, L2, neutral (N) and ground in the transfer switch.

**NOTICE** Refer to the National Electric Code for correct electrical field connections and wire size calculations.

## Final Installation Considerations

### Engine Oil

**NOTICE** Any attempt to crank or start the engine before it has been correctly filled with the recommended oil will result in equipment failure and service codes.

- Refer to *Maintenance* in the *Operation* section of this manual for oil fill information.
- Damage to equipment resulting from failure to obey this instruction will void the engine and generator warranty.

This engine is shipped from the factory pre-run and filled with synthetic oil (API SJ/CF 5W-30). This allows for system operation in a wide range of temperature and climate conditions. Before starting the engine, check the oil level as described in the *Maintenance* section of this manual.

The use of synthetic oil does not alter the required oil change intervals described in the *Operation* section of this manual.

For operation in temperatures below 30°F (-1°C), the use of fully synthetic oil (minimum API SJ) of viscosity 5W30 is required.

## Battery



**WARNING**



Storage batteries give off explosive hydrogen gas during recharging. Slightest spark could ignite hydrogen and cause explosion, resulting in death or serious injury.

- DO NOT dispose of battery in a fire. Recycle battery.
- DO NOT allow any open flame, spark, heat, or lit cigarette during and for several minutes after charging a battery.

**WARNING**

Generator and utility voltage could cause electrical shock or burn resulting in death or serious injury.

- Installation must be performed by a licensed professional.
- Disconnect all sources of electricity before installing or servicing equipment.
- Ground system before applying power.

**WARNING**

Battery electrolyte fluid contains acid and is extremely caustic. Contact with battery contents could cause severe chemical burns.

- DO NOT open or mutilate the battery
- Wear protective goggles, rubber apron, rubber boots and rubber gloves.
- Immediately wash electrolyte from skin with water.
- If electrolyte contacts eyes, immediately flush with water and seek medical attention.
- Spilled electrolyte is to be washed down with an acid neutralizing agent.

The installer must supply and install a rechargeable 12 volt starting battery. The starting battery MUST conform to the specifications shown in this chart.

Battery Specifications		
Specifications	Standard	Cold Start (Less than 30°F / -1°C)
Volts	12 Volt DC	12 Volt DC
Amps (Minimum)	540 CCA (Cold Cranking Amps)	800 CCA (Cold Cranking Amps)
Construction	Wet Lead Acid	Wet Lead Acid
Terminal Type	Top Post Type Battery	Top Post Type Battery
Dimensions (Maximum)	BCI Size 26 or BCI Size 51	BCI Size 24

**WARNING**

With the battery connected, the generator may crank and start without warning resulting in death or serious injury.

- Do not connect the negative (-) cable at the battery until the installation is complete.

Install the battery as described in *Servicing the Battery* in the *Maintenance* section of this manual. Always make sure that the NEGATIVE cable is connected last and that the red POSITIVE terminal insulator is secure.

Use the supplied tie-down strap to secure the battery to the unit. Each end of the strap should be attached to the existing tabs in the base of the unit.

## System Control Board

**NOTICE** Please see separate online manual: "Operation Instructions GC1031 GENSET Controller" (part number 80086364) for details on set up and operation.

The generator control panel, located inside the generator housing, is shown below. Brief descriptions of the controls used during installation are:

- (A) Menu / Programming Navigation Buttons
- (B) Stop / Config Button
- (C) Start / Select Button
- (D) Auto / Manual Button
- (E) Alarm
- (F) Digital Display — Displays generator mode, menu options, and alarms.

Detailed descriptions of the controls are located in the *Description of Control Keys* section inside the online "Operation Instructions GC1031 GENSET Controller" manual (part number 80086364).

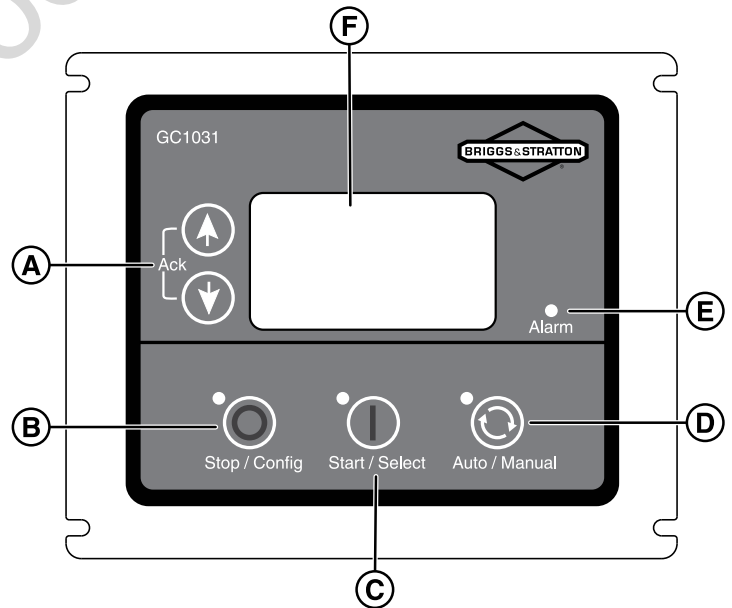

## Initial Start-Up (No Load)



Exhaust heat/gases could ignite combustibles causing a fire, resulting in death or serious injury.

- Remove all combustible materials from in and around the generator compartment.

The unit has been set-up for NG operation at the factory. Fuel conversion, if needed, must be completed prior to performing these steps. See Fuel Conversion.

Before operating the standby generator or placing it into service, inspect the entire installation carefully. Then begin testing the system without any electrical loads connected, as follows:

**NOTICE** When the generator is started for the very first time, it will require that any air in the gaseous fuel lines be purged. This can cause the engine to run roughly for a few minutes.

1. Remove three screws (A) that secure control box cover to enclosure to expose unit's circuit breaker.
2. Connect an accurate multi-meter to line side of generator's main circuit breaker.
3. Set generator's main circuit breaker to ON (closed) position.
4. Remove the battery panel.
5. Install 15 Amp fuse in the fuse holder behind the battery panel.
6. Push the ON/OFF Switch on the back of the generator to the "ON" (I) position.
7. Push the START/SELECT button on the control board. The engine will start in Low Idle Mode (LIM). Push again to bring the engine to full speed.
8. Listen for unusual noises, vibration or other indications of abnormal operation. Check for oil leaks while engine runs.
9. Let engine warm up for approximately 5 minutes to allow internal temperatures to stabilize.
10. Check generator output at load side of circuit breaker. Voltage should be 225 - 250 Volts, frequency should be 59.0 - 61.0 Hz.
11. Check generator output between one generator connection lug and neutral lug, then between other generator connection lug and neutral lug. In both cases, voltage reading should be between 112 and 125 Volts.
12. Push the STOP/CONFIG button on the control board. The engine will enter cool-down mode for approximately 5 minutes. Push again to stop the engine.
13. Install control box cover again.
14. Install the battery panel.



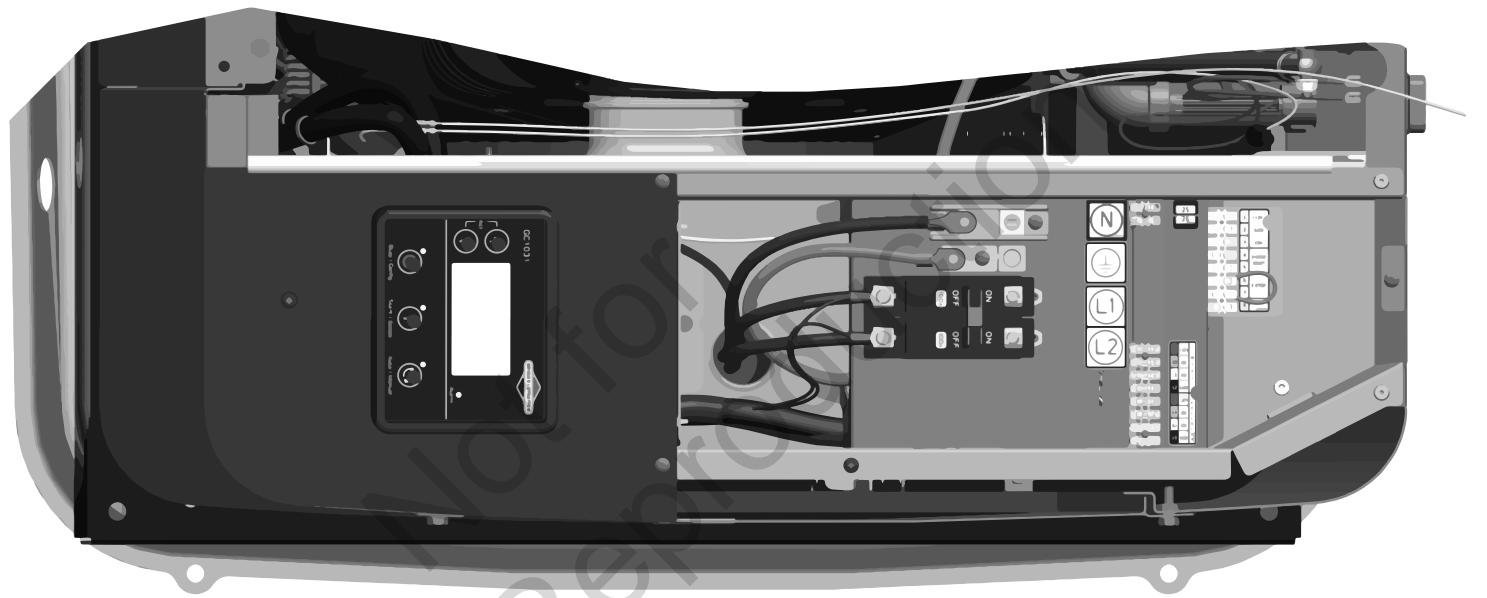
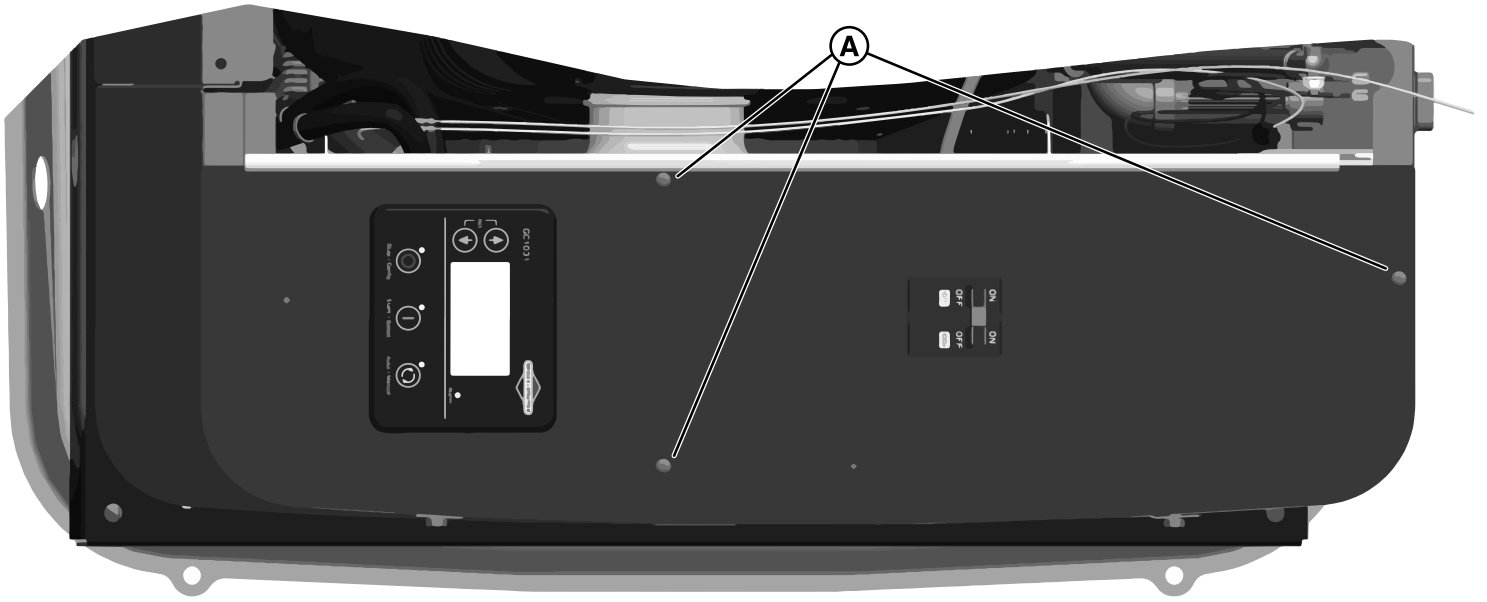

# Operation

## Features and Controls - 17kW and 20kW Generators



**WARNING**



Failure to read and obey the operator's manual, all warnings, and operating instructions could result in death or serious injury.

### 17kW and 20kW Generator (Front View)

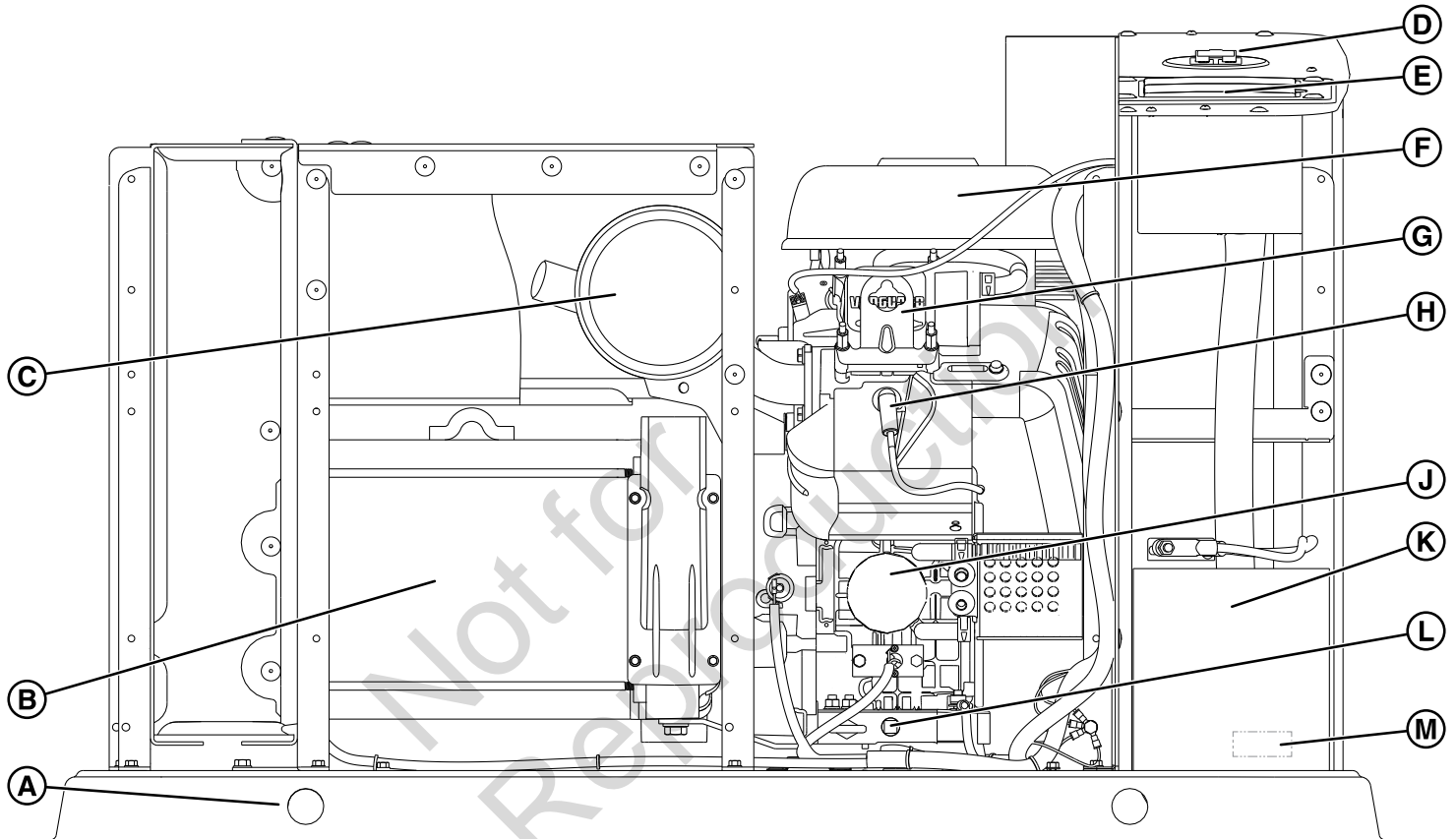

Generator is shown with roof and access covers removed for clarity.

Legend for System Connector Locations:

- (A) Lifting Holes — Provided at each corner for lifting generator.
- (B) Alternator — An electrical machine that generates an alternating current
- (C) Muffler — High-performance muffler lowers engine noise to comply with most residential codes.
- (D) Circuit Breaker — Protects the system from shorts and other over-current conditions.
- (E) Control Board — Used for generator operation control, menu start-up, and informational display functions.
- (F) Air Cleaner — Uses a dry type filter element to protect engine by filtering dust and debris out of intake air
- (G) Engine Label — Identifies engine model and type (located on the valve cover).
- (H) Spark Plug — A device in the cylinder head of the engine that ignites the fuel mixture by means of an electric spark.
- (J) Oil Filter — Filters engine oil to prolong generator life.
- (K) Battery (installer supplied) — 12 Volt DC, lead acid, automotive style battery provides power to start the engine.

(L) Oil Drain Hose — Provided to facilitate oil changing.

(M) Generator Data Label — Identifies generator model number and serial number. Located inside battery access compartment.

### 17kW and 20kW Generator (Back View)

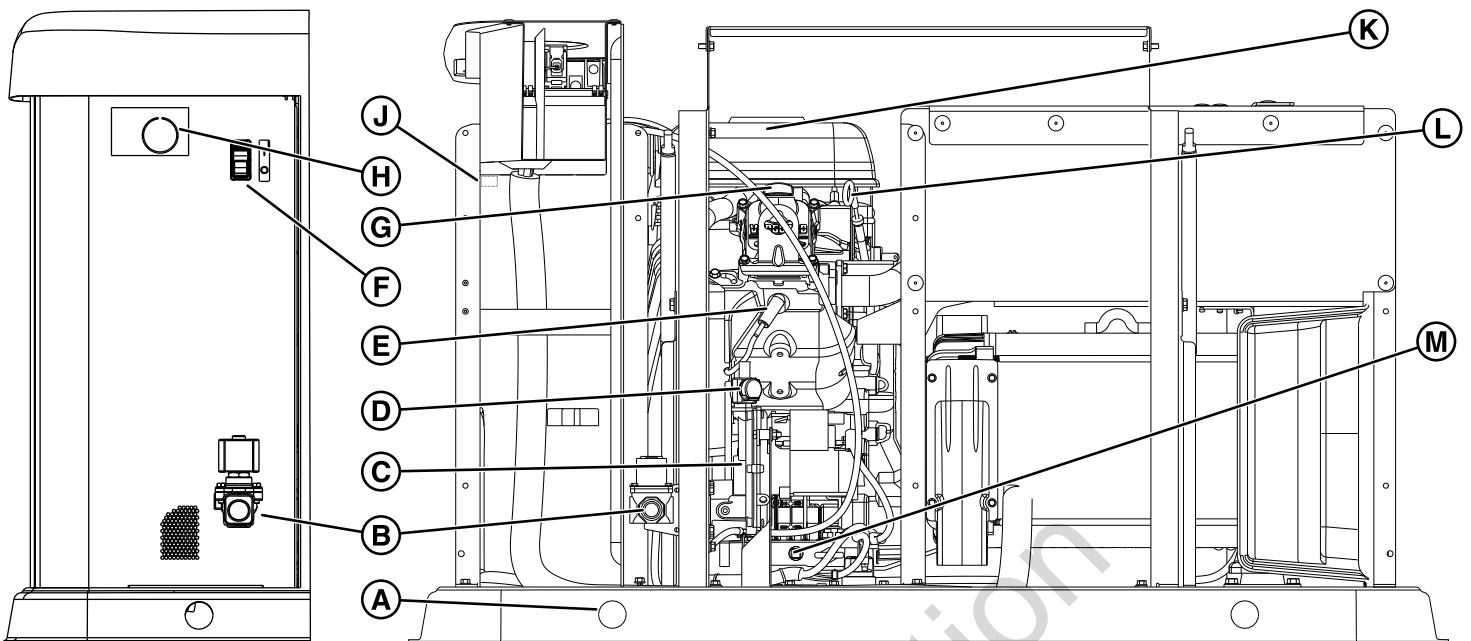

(A) Lifting Holes — Provided at each corner for lifting generator.

(B) Fuel Solenoid — Automatically opens and closes to supply fuel to unit when needed.

(C) Fuel Regulator — Controls fuel flow to engine for proper operation.

(D) Fuel Selector Valve — Used to select proper fuel type (LP or NG).

(E) Spark Plug — A device in the cylinder head of the engine that ignites the fuel mixture by means of an electric spark.

(F) ON / OFF Switch — Used to turn the generator on (I) and off (O).

(G) Oil Fill Cap — Location for adding oil to engine.

(H) Electrical Field Wiring Inlet — Wires to and from generator are centered in this location.

(J) Fuse Holder — For the 15 Amp ATO-type fuse (fuse holder is located in the upper battery bay).

(K) Air Cleaner — Uses a dry type filter element to protect engine by filtering dust and debris out of intake air.

(L) Engine Oil Dipstick — Allows user to check engine oil level easily.

(M) Oil Heater — Provided to warm engine oil to promote easy starting in cold climates.

## Important Owner's Considerations



Engine exhaust contains carbon monoxide, a poisonous gas that could kill you in minutes. You cannot smell it, see it, or taste it. Even if you do not smell exhaust fumes, you could still be exposed to carbon monoxide gas.

- Carbon monoxide detector(s) MUST be installed and maintained indoors according to the manufacturer's instructions/recommendations. Smoke alarms cannot detect carbon monoxide gas.
- If you start to feel sick, dizzy, weak, or your carbon monoxide alarm sounds while using this product, get to fresh air right away. Call emergency services. You may have carbon monoxide poisoning.



Propane and Natural Gas are extremely flammable and explosive, which could cause burns, fire or explosion resulting in death or serious injury.

- The generator is equipped with an automatic safety gas fuel shut-off valve.
- DO NOT operate the equipment if the fuel shut-off valve is missing or inoperative.

### Engine Oil

The engine is shipped from the factory pre-run and filled with synthetic oil (API SJ/CF 5W-30). This allows for system operation in a wide range of temperature and climate conditions. Before starting the engine, check the oil level as described in *Maintenance*.

**NOTICE** Any attempt to crank or start the engine without being correctly filled with the recommended oil will result in equipment failure.

- Damage to equipment resulting from failure to obey this instruction will void engine and generator warranty.

### Battery

The installer must supply a rechargeable 12 volt DC starting battery. See Battery in *Final Installation Considerations* in this manual.

### 15 Amp Fuse

Make sure that the fuse is correctly installed before operating your generator.

## Automatic Operation Sequence

The generator's control board monitors utility voltage. If the utility voltage drops below a preset level, the control board will signal the engine to crank and start. When the utility

voltage is restored above a preset voltage level, the engine is signaled to shut down. The actual system operation is not adjustable and is sequenced by sensors and timers on the control board, as follows:

### Utility Voltage Dropout Sensor

- This sensor monitors the utility source voltage.
- If the utility source voltage drops below approximately 70 percent of the nominal supply voltage, the sensor initiates a timer. The timer is used to 'sense' brown-outs.
- Once the timer has expired, the engine will crank and start.

### Utility Voltage Pickup Sensor

This sensor monitors the utility voltage. When the utility voltage is restored above approximately 80 percent of the nominal source voltage, a shut-down timer is initiated and the engine will go to engine cool-down.

### Engine Cool-down Timer

When the utility power is sensed, the load transfers to the utility source and the engine will go into a 5 minute cool down period.

## Setting the Exercise Timer

1. Push and hold the Stop/Config button (B).
2. Push the Start/Select button (C) to enter WRITE MODE.
3. Enter the password (0000) by using the arrow keys (A) and the Start/Select button (C).
4. In the CONFIGURATION screen use the arrow keys (A) to find MODULE.
5. Push the Start/Select button (C) and using the arrow keys (A) find AUTO EXERCISE.
6. Push the Start/Select button (C) and using the arrow keys (A) select each parameter and choose the desired settings.
7. To save your settings when completed, push and hold the Stop/Config button (B) until "Saving Settings" shows on the display.

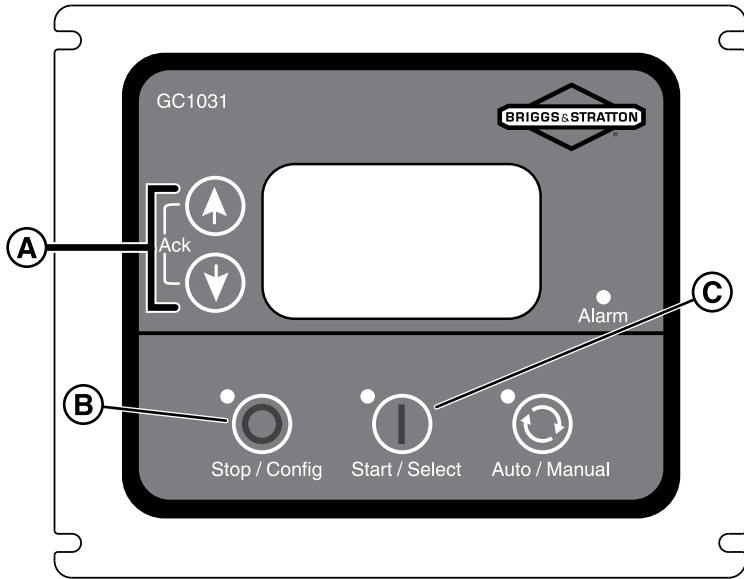

A detailed list of all the on screen parameters is located in the *Configuration of GCU* section inside the online *"Operation Instructions GC1031 GENSET Controller"* manual (part number 80086364)

Not for  
Reproduction

# Maintenance

## Servicing the System



**WARNING**



Generator and utility voltage could cause electrical shock or burn resulting in death or serious injury.

- DO NOT allow unqualified persons to operate or service this equipment.



**WARNING**



With the battery connected, the generator may crank and start without warning resulting in death or serious injury.

- Before servicing, stop the generator and disconnect the negative (-) cable at the battery.

Before performing any generator maintenance, always do the following steps

1. Push the ON/OFF Switch on the back of the generator to the "OFF" (0) position.
2. Remove utility power to the generator to de-energize the battery charger.
3. Unlock and open the roof as described in the *Access Panels* section of this manual.
4. Remove the battery panel.
5. Remove the 15 Amp fuse from the fuse holder located behind the battery panel.
6. Disconnect the negative (-) cable at the battery.
7. Perform service steps as specified.
8. Connect the negative (-) cable at the battery.
9. Install the 15 Amp fuse into the fuse holder.
10. Install the battery panel.
11. Close and lock the roof.
12. Restore utility power to the generator.
13. Push the ON/OFF Switch on the back of the generator to the "ON" (I) position.
14. Set the generator mode to AUTO.

## Maintenance Schedule

Follow the hourly or calendar intervals of operation, whichever occurs first.

<b>Every 8 Hours of Operation or Daily</b>
Clean Debris
Check the Engine Oil Level
<b>Every 100 Hours of Operation or Annually</b>
Change the Air Filter
Change the Engine Oil and Filter
Replace the Spark Plugs

Check the Valve Clearance
Check the Circuit Breaker Torques
<b>Annually</b>
Clean the Oil Cooler Fins

Regular maintenance will improve the performance and extend the life of the generator. See any authorized dealer for service.

## Emissions Control

Maintenance, replacement, or repair of the emissions control devices and systems can be done by any non-road engine repair establishment or an individual. However, to obtain "no change" emissions control service, the work must be done by a factory authorized dealer. See the Emissions Warranty.

## Generator Maintenance

The generator's warranty does not cover items that have been subjected to operator abuse or negligence. To receive full value from the warranty, the operator must maintain the generator as instructed in this manual.

Some adjustments will need to be made periodically to correctly maintain your generator.

All service and adjustments must be made at least once each season. Obey the requirements in the *Maintenance Schedule* chart.

Generator maintenance consists of keeping the unit clean. Operate the unit in an environment where it will not be exposed to excessive dust, dirt, moisture or any corrosive vapors. The cooling air louvers on the enclosure must not become clogged with snow, leaves, or other foreign material. To prevent generator damage caused by overheating, keep the enclosure cooling inlets and outlets clean and unobstructed at all times.

Check the cleanliness of the unit frequently and clean when dust, dirt, oil, moisture or other foreign substances are visible on its exterior/interior surface. Inspect the air inlet and outlet openings inside and outside the enclosure to make sure the air flow is not blocked.

**NOTICE** Incorrect treatment of generator can damage it and shorten its life.

- DO NOT expose generator to excessive moisture, dust, dirt, or corrosive vapors.
- DO NOT insert any objects through cooling slots.

## Cleaning the Generator

 **WARNING**

 Exhaust heat/gases could ignite combustibles causing a fire, resulting in death or serious injury.

- Keep the area near the generator clean and free of debris.

**NOTICE** DO NOT use direct spray from a garden hose to clean generator. Water can enter the engine and generator and cause damage.

**NOTICE** Periodically inspect the engine exterior for contamination and potential damage from dirt, leaves, rodents, spider webs, insects, etc. and remove.

1. Push the ON/OFF Switch on the back of the generator to the “OFF” (0) position.
2. Remove utility power to the generator to de-energize the battery charger.
3. Unlock and open the roof as described in the *Access Panels* section of this manual.
4. Remove the battery panel.
5. Remove the 15 Amp fuse from the fuse holder located behind the battery panel.
6. Disconnect the negative (-) cable at the battery.
7. Clean generator as follows: Use a damp cloth to wipe exterior surfaces clean. Use a soft, bristle brush and vacuum cleaner to loosen and pick up dirt and debris. Use low pressure air (not to exceed 25 psi) to blow away dirt and debris. Clean the air inlets and outlets of any snow, leaves, or debris. To prevent generator damage caused by overheating, these openings must be kept unobstructed.
8. Connect the negative (-) cable at the battery.
9. Install the 15 Amp fuse into the fuse holder.
10. Install the battery panel.
11. Close and lock the roof.
12. Restore utility power to the generator.
13. Push the ON/OFF Switch on the back of the generator to the “ON” (I) position.
14. Set the generator mode to AUTO.

## Engine Maintenance

### Engine Oil

Use only Briggs & Stratton® 80028446 SAE 5W-30 full synthetic engine oil.

### Checking Engine Oil Level

Oil must be maintained between the “ADD” and the “FULL” marks on the dipstick. To make sure that an accurate reading is shown on the dipstick, make sure the following steps are taken before checking the oil level.

1. Push the ON/OFF Switch on the back of the generator to the “OFF” (0) position.

2. Remove utility power to the generator to de-energize the battery charger.
3. Unlock and open the roof as described in the *Access Panels* section of this manual.
4. Remove the battery panel.
5. Remove the 15 Amp fuse from the fuse holder located behind the battery panel.
6. Disconnect the negative (-) cable at the battery.
7. Allow approximately five minutes for the oil to drain back into the oil pan.
8. Remove the dipstick. Wipe it with a clean cloth or paper towel. Then, push the dipstick all the way into the dipstick tube.
9. Remove the dipstick and note the amount of oil on the dipstick. The oil level must be between the “ADD” and “FULL” marks.
10. If the oil level is below the “ADD” mark, install the dipstick and proceed to step 8.

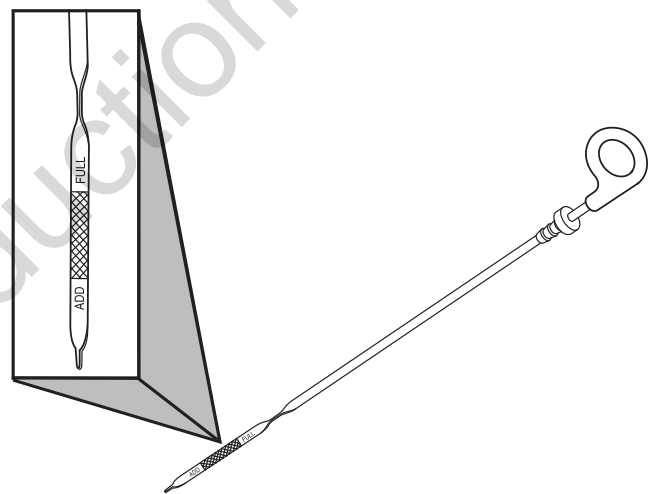

11. Remove the oil filler cap from the valve cover.
12. Add the required amount of oil to bring the level up to, but not over, the “FULL” mark on the dipstick. Install the oil filler cap to the valve cover and wipe up any spilled oil.
13. Connect the negative (-) cable at the battery.
14. Install the 15 Amp fuse into the fuse holder.
15. Install the battery panel.
16. Close and lock the roof.
17. Restore utility power to the generator.
18. Push the ON/OFF Switch on the back of the generator to the “ON” (I) position.
19. Set the generator mode to AUTO.

## Changing Engine Oil and Oil Filter

Change the oil while the engine is still warm from running.

1. Push the ON/OFF Switch on the back of the generator to the "OFF" (0) position.
2. Remove utility power to the generator to de-energize the battery charger.
3. Unlock and open the roof as described in the *Access Panels* section of this manual.
4. Remove the battery panel.
5. Remove the 15 Amp fuse from the fuse holder located behind the battery panel.
6. Disconnect the negative (-) cable at the battery.
7. Place the oil drain hose into an approved container.
8. Remove the brass fitting from the end of the oil drain hose.
9. When the oil has drained, replace the brass fitting on the hose.
10. Put an approved container beneath the oil filter area.
11. Remove the oil filter and dispose of it correctly.
12. Before installing a new oil filter, lightly lubricate the oil filter gasket with fresh and clean oil.
13. Install the oil filter by hand until the gasket contacts the oil filter adapter, then tighten the oil filter  $\frac{1}{2}$  to  $\frac{3}{4}$  turn.
14. Add the required amount of oil to bring the level up to, but not over, the "FULL" mark on the dipstick. Install the oil filler cap and wipe up any spilled oil.
15. Connect the negative (-) cable at the battery.
16. Install the 15 Amp fuse into the fuse holder.
17. Install the battery panel.
18. Close and lock the roof.
19. Restore utility power to the generator.
20. Push the ON/OFF Switch on the back of the generator to the "ON" (I) position.
21. Set the generator mode to AUTO.

## Engine Oil

The engine is filled with synthetic oil (API SJ/CF 5W-30). This allows for system operation in the widest range of temperature and climate conditions.

We recommend the use of Briggs & Stratton® 80028446 SAE 5W-30 full synthetic engine oil. Other high-quality detergent oils are acceptable if classified for service SJ or higher. Do not use special additives.

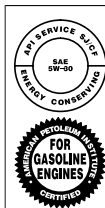

*Note:* Synthetic oil meeting ILSAC GF-2, API certification mark and API service symbol with "SJ/CF ENERGY CONSERVING" or higher, is an acceptable oil at all temperatures. Use of synthetic oil does not alter required oil change intervals.

## Adjust Valve Lash

The valve lash must be checked every 100 hours of operation. Measure the valve clearance with the engine cold. To adjust the valve lash, proceed as follows:

1. Push the ON/OFF Switch on the back of the generator to the "OFF" (0) position.
2. Remove utility power to generator to de-energize the battery charger.
3. Unlock and open the roof as described in the *Access Panels* section of this manual.
4. Remove the battery panel.
5. Remove the 15 Amp fuse from the fuse holder located behind the battery panel.
6. Disconnect the negative (-) cable at the battery.
7. Remove both spark plugs to ease manual rotation of engine crankshaft.
8. Access to rotate the engine by hand is available by:
  - A. Removing the engine intake screen in the battery compartment such that the crankshaft nut is accessible. Care must be taken when reassembling this screen using the self tapping screws as over-torqueing will strip out the partition material.
  - B. OR remove the front alternator outlet air scoop by removing the four screws that secure it. The crankshaft may be rotated via the aluminum alternator fan. Care should be taken not to damage the fan, and to reinstall the alternator outlet air scoop in the proper orientation.
9. Set the No. 1 cylinder at  $\frac{1}{4}$ " (6mm) past Top Dead Center (TDC) on the compression stroke.
10. Using a feeler gage (A), measure the valve clearance.
11. For proper valve clearance for both the intake and exhaust see *Engine Specifications* Section
12. Adjust the clearance by loosening the lock nut (B), then turn the adjusting screw (C).
13. Once the clearance is properly set, hold the adjusting screw while torqueing the lock nut to 70 in-lbs (8Nm).
14. Repeat these steps for cylinder No. 2.
15. Connect the negative (-) cable at the battery.
16. Install the 15 Amp fuse into the fuse holder.
17. Install the battery panel.
18. Close and lock the roof.
19. Restore utility power to the generator.
20. Push the ON/OFF Switch on the back of the generator to the "ON" (I) position.
21. Set the generator mode to AUTO.



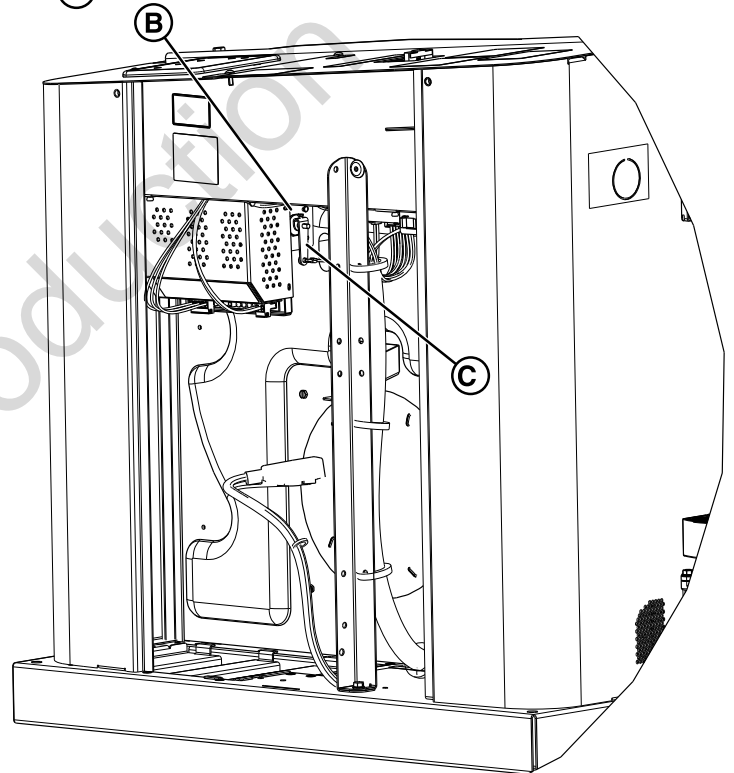
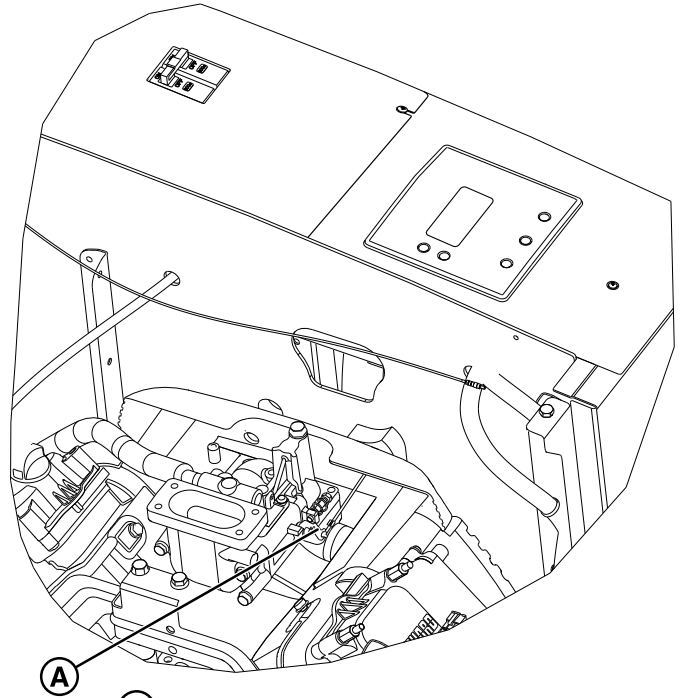
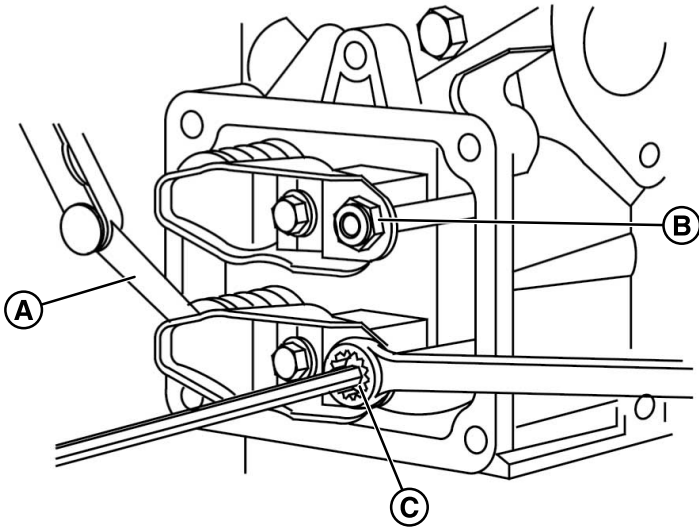

## Electronic Governor System

The engine electronic governor system allows for improved control and increased generator performance compared to mechanically governed systems. The result is a smooth steady-state operation without the “hunting” common to many mechanical governors. The system also reduces speed variations under engine loading and unloading and significantly reduces frequency fluctuation experienced when the engine is under higher loads.

The electronic governor system is composed of a stepper motor (B), stepper motor throttle control linkages (C), and throttle side linkage (A). The control board contains a digital controller that processes engine speed information and sends appropriate commands to the stepper motor to control the position of the engine throttle.

Since the electronic governing system controls the engine throttle demand based on generator load, the following service codes and/or conditions can be related to an electronic governing system issue:

- Engine Does Not Start
- Over Speed
- Under Frequency
- Unstable No Load Engine Control

While troubleshooting any of these conditions, a verification of the electronic governor system can be initiated through the control panel – Actuator Test.

## Electronic Governing Check

The generator has an electronic governing check feature that will turn on the stepper motor and move the throttle linkage clockwise and counterclockwise within the throttle limits. The test will rotate the stepper motor and move the throttle arm between the wide open throttle and dead idle limits for up to 10 seconds. This will allow visual verification that the stepper motor is functioning correctly and the control linkages are connected. The engine will not attempt to start during this test. If the stepper motor does not move, or if a linkage binds, then service will be required.

**NOTICE** If stepper motor does not move, please make sure the stepper motor connector is attached.

## Service the Spark Plugs



### WARNING

Unintentional sparking could cause fire or electric shock resulting in death or serious injury.

### WHEN ADJUSTING OR MAKING REPAIRS TO YOUR GENERATOR

- Disconnect the spark plug wire from the spark plug and place the wire where it cannot contact spark plug.

### WHEN TESTING FOR ENGINE SPARK

- Use approved spark plug tester.
- DO NOT check for spark with spark plug removed.

Changing the spark plugs will help your engine to start easier and operate better.

1. Push the ON/OFF Switch on the back of the generator to the "OFF" (0) position.
2. Remove utility power to the generator to de-energize the battery charger.
3. Unlock and open the roof as described in the *Access Panels* section of this manual.
4. Remove the battery panel.
5. Remove the 15 Amp fuse from the fuse holder located behind the battery panel.
6. Disconnect the negative (-) cable at the battery.
7. Clean the area around spark plugs.
8. Remove and inspect spark plugs.
9. Check electrode gap (A) with wire feeler gauge (B) and reset spark plug gap to recommended gap if necessary (see *Engine Specifications* at the end of this manual).

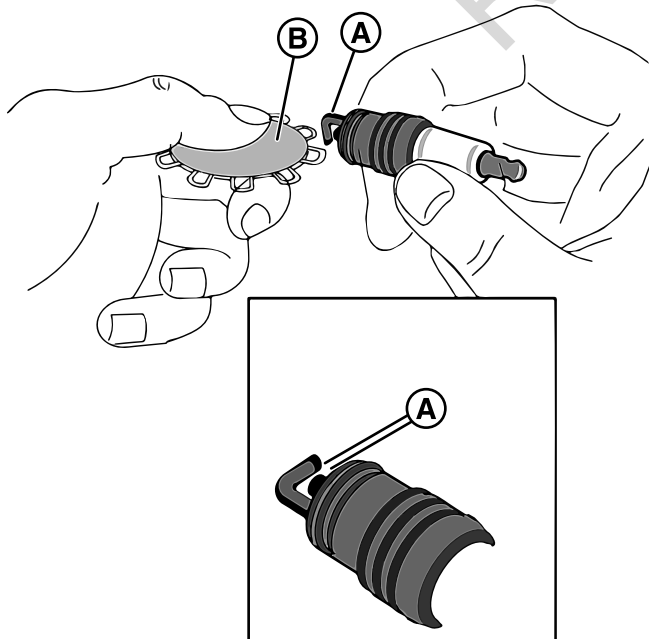

10. Replace the spark plugs if the electrodes are pitted, burned or the porcelain is cracked. Use the recommended replacement spark plugs (see *Engine Specifications* at the end of this manual).
11. Install the spark plugs and tighten them to 180 in/lbs (20 Nm).
12. Connect the negative (-) cable at the battery.
13. Install the 15 Amp fuse into the fuse holder.
14. Install the battery panel.
15. Close and lock the roof.
16. Restore utility power to the generator.
17. Push the ON/OFF Switch on the back of the generator to the "ON" (I) position.
18. Set the generator mode to AUTO.

## Engine Air Cleaner



### WARNING



Gaseous vapors are extremely flammable and explosive. Fire or explosion can cause severe burns or death.

- Never start and run the engine with the air cleaner assembly (if equipped) or the air filter (if equipped) removed.
1. Push the ON/OFF Switch on the back of the generator to the "OFF" (0) position.
  2. Remove utility power to the generator to de-energize the battery charger.
  3. Unlock and open the roof as described in the *Access Panels* section of this manual.
  4. Remove the battery panel.
  5. Remove the 15 Amp fuse from the fuse holder located behind the battery panel.
  6. Disconnect the negative (-) cable at the battery.
  7. Remove filter cartridge.
  8. Clean the outlet tube and check the Dust Unloader Valve (if equipped) - Use a clean cloth to wipe the filter sealing surface and the outlet tube surfaces. Make sure that all contaminant is removed before the new filter is inserted. Do not damage the sealing area on the tube. Check and squeeze the Dust Unloader Valve that is attached to the service cover to make sure it is flexible and not inverted, damaged or plugged.
  9. Clean the filter - Use a soft bristle brush to loosen dirt and a vacuum cleaner to remove dirt and debris. Replace the filter cartridge if you find any holes in the filter media.
  10. Install the clean filter correctly - Insert the filter carefully. Seat the filter by hand. Make sure it is completely seated in the air cleaner housing before you put the cover in place.
  11. Install the service cover. Make sure that all mounting bands, clamps, bolts, and connections in the entire air

cleaner system are tight and make sure there are no holes in piping - repair if needed.

12. Connect the negative (-) cable at the battery.
13. Install the 15 Amp fuse into the fuse holder.
14. Install the battery panel.
15. Close and lock the roof.
16. Restore utility power to the generator.
17. Push the ON/OFF Switch on the back of the generator to the "ON" (I) position.
18. Set the generator mode to AUTO.

## Exhaust System Maintenance



### WARNING



Contact with muffler area could cause burns resulting in serious injury.

- DO NOT touch hot parts and AVOID hot exhaust gases.
- Allow equipment to cool before touching.

When inspecting the exhaust system, check the following:

- Inspect the exhaust manifold at the cylinder head for leaks.
- Check that all retaining bolts and shields (if used) are in place.
- Inspect the fasteners between the manifold and the exhaust pipe to make sure they are tight and that there are no exhaust leaks. Repair as necessary.
- Inspect exhaust pipe connection for leaks. Repair as necessary.

It is a violation of California Public Resource Code, Section 4442, to use or operate the engine on any forest-covered, brush-covered, or grass-covered land unless the exhaust system is equipped with a spark arrester, as defined in section 4442, maintained in effective working order. Other states or federal jurisdictions may have similar laws; reference Federal Regulation 36 CFR Part 261.52.

## Fuel System Maintenance



### WARNING



Propane and Natural Gas are extremely flammable and explosive, which could cause burns, fire or explosion resulting in death or serious injury.

- Inspect the fuel system periodically.
- NO leakage is permitted.
- DO NOT operate engine if smell of fuel is present.

## Pressure Regulator

The pressure regulator components have been specifically designed and calibrated to meet the fuel system requirements of the engine.

If the regulator fails to operate or develops a leak, it must be repaired or replaced with the OEM recommended replacement parts. When inspecting the regulator, check the following:

- Check for any fuel leaks at the inlet and outlet fittings.
- Check for any fuel leaks in the regulator body.
- Check to make sure the regulator is correctly mounted and the mounting bolts are tight.
- Check the regulator for external damage.

## Mixer/Throttle Control Device

The mixer and throttle body components have been specifically designed and calibrated to meet the fuel system requirements of the engine.

A dirty air filter can significantly alter the mixer performance. Make sure the air filter is clean. When inspecting the mixer and throttle body, check the following:

- Check for leaks at all the fittings.
- Make sure the mixer and throttle body are securely mounted.
- Inspect and clean the air filter element according to the recommended service intervals listed in the maintenance chart.
- Inspect air inlet hose connection and clamp. Inspect hose for cracking, splitting, or chafing. Replace as necessary.
- Check fuel lines for cracking, splitting, or chafing. Replace as necessary.
- Check for leaks at the throttle body and intake manifold.

## Alarms (Service Code Detection System)

The generator will have to run for long periods of time with no operator present. For that reason, the system is equipped with sensors that automatically shut down the generator in the event of potentially damaging conditions, such as low oil pressure, high temperature, over speed, and other conditions.

The generator's control board shows service alarm descriptions on the digital display. The service alarm descriptions are listed in the "Alarms" section inside the online "Operation Instructions GC1031 GENSET Controller" manual (part number 80086364).

## Acknowledge and Reset the Alarms (Service Code Detection System)

Push the up and down arrows (A) simultaneously to reset the alarm.

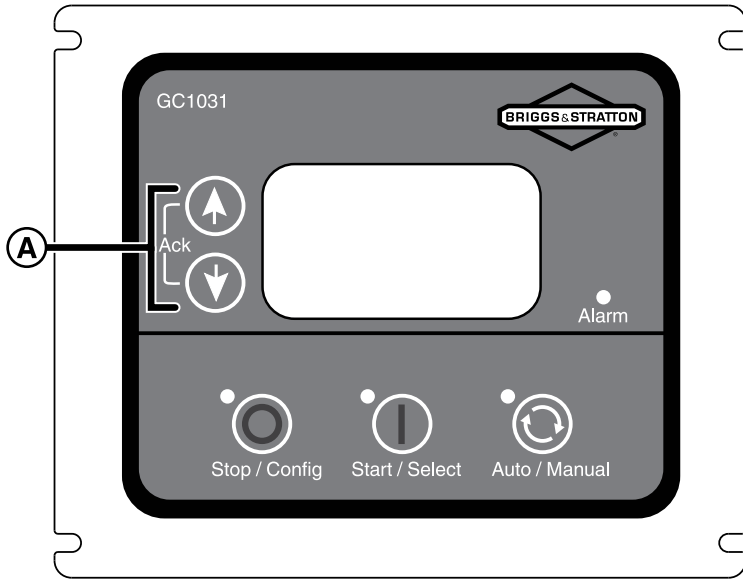

**WARNING**

Battery electrolyte fluid contains acid and is extremely caustic. Contact with battery contents could cause severe chemical burns.

- DO NOT open or mutilate the battery
- Wear protective goggles, rubber apron, rubber boots and rubber gloves.
- Immediately wash electrolyte from skin with water.
- If electrolyte contacts eyes, immediately flush with water and seek medical attention.
- Spilled electrolyte is to be washed down with an acid neutralizing agent.

**WARNING**

Storage batteries give off explosive hydrogen gas during recharging. Slightest spark could ignite hydrogen and cause explosion, resulting in death or serious injury.

- DO NOT dispose of battery in a fire. Recycle battery.
- DO NOT allow any open flame, spark, heat, or lit cigarette during and for several minutes after charging a battery.

## Electrical System Maintenance

### Wiring and Connections

The generator electrical system incorporates computers to control various components. The electrical system connectors and grounds require good connections. When inspecting the electrical system, check the following:

- Check the positive (+) and the negative (-) battery cables for corrosion, rubbing, chafing, burning, and make sure there are tight connections at both ends.
- Check the battery for cracks or damage to the case. Replace as necessary.
- Inspect the engine wire harness for rubbing, chafing, pinching, burning, and cracks or breaks in the wiring.
- Make sure that the engine harness connectors are correctly locked in.
- Inspect the ignition coil wire for hardening, cracking, chafing, burning, separation, and split boot covers.
- Inspect the spark plug wires for hardening, cracking, chafing, burning, separation, and split boot covers.
- Replace the spark plugs at the required intervals listed in the maintenance chart.
- Make sure that all electrical components are securely mounted to the engine or chassis.
- Make sure that any additional electrical services installed by the owner are correctly installed in the system.

### Servicing the Battery

Servicing of the batteries is to be performed or supervised by personnel knowledgeable of batteries and the required precautions. Keep unauthorized personnel away from the batteries.

**WARNING**

A battery presents a risk of high short circuit current.

- Remove watches, rings, or other metal objects.
  - Use tools having insulated handles.
  - Disconnect charging source prior to connecting or disconnecting battery terminals.
  - Do not lay tools or metal parts on top of batteries.
  - Disconnect the negative (-) cable at the battery during installation and maintenance.
1. Push the ON/OFF Switch on the back of the generator to the "OFF" (0) position.
  2. Remove utility power to the generator to de-energize the battery charger.
  3. Unlock and open the roof as described in the *Access Panels* section of this manual.
  4. Remove the battery panel.
  5. Remove the 15 Amp fuse from the fuse holder located behind the battery panel.
  6. Disconnect the negative (-) cable at the battery.
  7. Disconnect the positive (+) cable at the battery.
  8. Service or replace the battery as required.
  9. Connect the positive (+) cable at the battery.
  10. Connect the negative (-) cable at the battery.
  11. Install the 15 Amp fuse into the fuse holder.

12. Install the battery panel.
13. Close and lock the roof.
14. Restore utility power to the generator.
15. Push the ON/OFF Switch on the back of the generator to the "ON" (I) position.
16. Set the generator mode to AUTO.

### Replacing the Battery

1. Push the ON/OFF Switch on the back of the generator to the "OFF" (0) position.
2. Remove utility power to the generator to de-energize the battery charger.
3. Unlock and open the roof as described in the *Access Panels* section of this manual.
4. Remove the battery panel.
5. Remove the 15 Amp fuse from the fuse holder located behind the battery panel.
6. Disconnect the negative (-) cable at the battery.
7. Disconnect the positive (+) cable at the battery.
8. Remove the battery and install replacement battery.



DON'T POLLUTE. CONSERVE RESOURCES.  
RETURN USED BATTERY TO RECYCLING  
COLLECTION CENTER.

9. Connect the positive (+) cable at the battery.
10. Connect the negative (-) cable at the battery.
11. Install the 15 Amp fuse into the fuse holder.
12. Install the battery panel.
13. Close and lock the roof.
14. Restore utility power to the generator.
15. Push the ON/OFF Switch on the back of the generator to the "ON" (I) position.
16. Set the generator mode to AUTO.

### Charging the Battery

If it is necessary to charge the battery, proceed as follows:

1. Push the ON/OFF Switch on the back of the generator to the "OFF" (0) position.
2. Remove utility power to the generator to de-energize the battery charger.
3. Unlock and open the roof as described in the *Access Panels* section of this manual.
4. Remove the battery panel.
5. Remove the 15 Amp fuse from the fuse holder located behind the battery panel.
6. Disconnect the negative (-) cable at the battery.

**NOTICE** Failure to disconnect negative battery cable could result in equipment failure. DO NOT attempt to jump start the generator. Damage to equipment resulting from failure to follow this instruction will void engine and generator warranty.

7. Charge battery with the battery charger at 2 Amps until the battery holds 12 Volts. DO NOT exceed 13.7 volts when charging the battery.

**NOTICE** DO NOT use a battery booster to quick charge a low battery.

8. Connect the negative (-) cable at the battery.
9. Install the 15 Amp fuse into the fuse holder.
10. Install the battery panel.
11. Close and lock the roof.
12. Restore utility power to the generator.
13. Push the ON/OFF Switch on the back of the generator to the "ON" (I) position.
14. Set the generator mode to AUTO.

# Troubleshooting

Instructions GC1031 GENSET Controller" manual (part number 80086364)

The service alarm descriptions and their causes are listed in the table of the "Alarms" section inside the online "Operation

## Troubleshooting

PROBLEM	CAUSE	CORRECTION
Engine is running, but no AC output is available.	<ol style="list-style-type: none"> <li>1. Circuit breaker is open or defective.</li> <li>2. Alarm on generator control board.</li> <li>3. Poor wiring connections or defective transfer switch.</li> </ol>	<ol style="list-style-type: none"> <li>1. Reset or replace circuit breaker.</li> <li>2. Refer to <i>Alarms</i> section inside the online "Operation Instructions GC1031 GENSET Controller" manual (part number 80086364). Contact local service facility.</li> <li>3. Check and repair or contact local service facility.</li> </ol>
Engine runs well at no-load but "bogs down" when loads are connected.	<ol style="list-style-type: none"> <li>1. Generator is overloaded.</li> <li>2. Short circuit in a connected load.</li> <li>3. Shorted generator circuit.</li> <li>4. Fuel pressure or mixture is incorrect.</li> <li>5. Kinked fuel line between regulator and engine.</li> <li>6. Clogged air filter.</li> </ol>	<ol style="list-style-type: none"> <li>1. Remove one or more loads.</li> <li>2. Disconnect shorted electrical load.</li> <li>3. Contact local service facility.</li> <li>4. See <i>Gaseous Fuel System</i> in this manual.</li> <li>5. Remove kink. Replace if necessary.</li> <li>6. Clean or replace air filter.</li> </ol>
Engine will not start; or starts and runs rough	<ol style="list-style-type: none"> <li>1. 15 Amp fuse missing or blown.</li> <li>2. Thermal fuse(s) blown.</li> <li>3. Fuel supply turned off or depleted.</li> <li>4. Incorrect fuel selection.</li> <li>5. Failed battery.</li> <li>6. Clogged air filter.</li> <li>7. Throttle linkage binding</li> </ol>	<ol style="list-style-type: none"> <li>1. Install (new) 15 Amp fuse. See <i>System Control Board</i></li> <li>2. Replace thermal fuse(s).</li> <li>3. Open fuel valve(s); check propane tank.</li> <li>4. Check fuel selector switch and set to proper setting. (If applicable)</li> <li>5. Replace battery.</li> <li>6. Clean or replace air filter.</li> <li>7. Check linkage.</li> </ol>
Engine shuts down during operation.	<ol style="list-style-type: none"> <li>1. Fuel supply turned off or depleted.</li> <li>2. Control board digital display shows an alarm.</li> </ol>	<ol style="list-style-type: none"> <li>1. Check fuel valves, fill propane tank.</li> <li>2. Refer to <i>Alarms</i> section inside the online "Operation Instructions GC1031 GENSET Controller" manual (part number 80086364).</li> </ol>
Loss of power on circuits.	<ol style="list-style-type: none"> <li>1. Generator circuit breaker is open.</li> <li>2. Transfer switch problems.</li> </ol>	<ol style="list-style-type: none"> <li>1. Reset circuit breaker.</li> <li>2. See transfer switch manual.</li> </ol>
Unit will not exercise.	<ol style="list-style-type: none"> <li>1. Control board not set to AUTO.</li> <li>2. Exercise timer not set or set to OFF.</li> <li>3. Unit date and time not set.</li> <li>4. Failed battery.</li> <li>5. 15 Amp fuse missing or blown.</li> </ol>	<ol style="list-style-type: none"> <li>1. Push AUTO button on control board.</li> <li>2. Set exercise timer.</li> <li>3. Set unit date and time.</li> <li>4. Replace the battery.</li> <li>5. Install a (new) 15 Amp fuse. See <i>System Control Board</i>.</li> </ol>
Excessive Vibration	<ol style="list-style-type: none"> <li>1. Loose mechanical fastener.</li> </ol>	<ol style="list-style-type: none"> <li>1. Check and repair or contact local service facility.</li> </ol>
Odor of fuel	<ol style="list-style-type: none"> <li>1. Fuel leak.</li> </ol>	<ol style="list-style-type: none"> <li>1. Turn off manual shutoff fuel valve. Contact local service facility.</li> </ol>
Utility power returns, unit does not stop	<ol style="list-style-type: none"> <li>1. Blown fuses in transfer switch.</li> <li>2. 5 minute cool down not lapsed.</li> <li>3. Poor wire connection or defective controllers.</li> </ol>	<ol style="list-style-type: none"> <li>1. Install (new) fuses.</li> <li>2. Wait 5 minutes.</li> <li>3. Check, repair or contact local service facility.</li> </ol>
Possible issues in MANUAL MODE	See Table 7 (Common faults and their remedial actions) inside the online "Operation Instructions GC1031 GENSET Controller" manual (part number 80086364).	

Possible issues in AUTO MODE	See Table 7 (Common faults and their remedial actions) inside the online "Operation Instructions GC1031 GENSET Controller" manual (part number 80086364).	
Possible issues with Electronic Governing	See Table 7 (Common faults and their remedial actions) inside the online "Operation Instructions GC1031 GENSET Controller" manual (part number 80086364).	

Not for  
Reproduction

# Diagrams and Schematics

## Wiring Diagram and Schematic

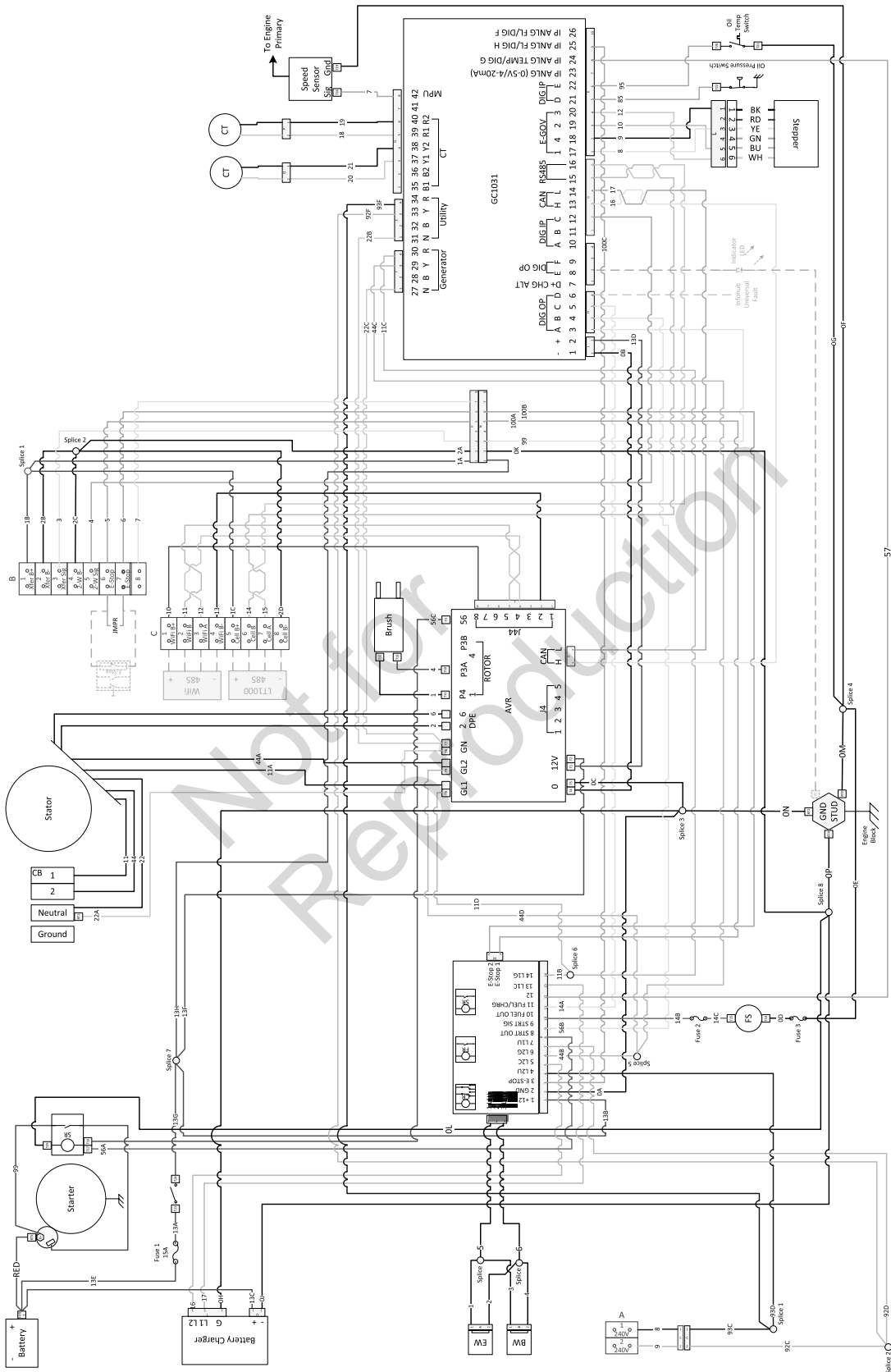



# Specifications

## Generator Specifications: 17kW and 20KW

\* 17k Watt.

Rated Maximum Load Current* (at 25°C/77°F, LP)*: at 240 Volts	70.8 Amps
Rated AC Voltage	120/240 Volts
Phase	Single phase
Rated Frequency	60 Hertz
Generator Breaker	80 Amp
Normal Operating Range	-20°F (-28.8°C) to 104°F (40°C)
Output Sound Level	69.1 dB(A) at 23 ft. (7 m) at normal load
Shipping Weight	610 lb (278 kg)

\* 20k Watt

Rated Maximum Load Current* (at 25°C/77°F, LP)*: at 240 Volts	83.3 Amps
Rated AC Voltage	120/240 Volts
Phase	Single phase
Rated Frequency	60 Hertz
Generator Breaker	100 Amp
Normal Operating Range	-20°F (-28.8°C) to 104°F (40°C)
Output Sound Level	69.1 dB(A) at 23 ft. (7 m) at normal load
Shipping Weight	626 lb (278 kg)

\* Natural gas rating will depend on specific fuel but typical derates are between 10 to 20% off the LP gas rating.

## Engine Specifications

\* 17k Watt.

Displacement	60.60 ci. (993 cc)
Bore	3.405 in. (86.5 mm)
Stroke	3.366 in. (85.5 mm)
Spark Plug Gap	0.020 in. (0.51 mm)
Spark Plug Torque	180 lb-in. (20 Nm)
Armature Air Gap	0.005 - 0.008 in. (0.13 - 0.20 mm)
Intake Valve Clearance	0.004 - 0.006 in. (0.10 - 0.15 mm)
Exhaust Valve Clearance	0.007 - 0.009 in. (0.15 - 0.23 mm)
Oil Type	5W30 Synthetic
Oil Capacity (with filter)	78 - 80 oz. (2.3 - 2.4 L)
Engine End Cover Bolt	220 lb-in (25Nm)

\* 20k Watt.

Displacement	60.60 ci. (993 cc)
Bore	3.405 in. (86.5 mm)
Stroke	3.366 in. (85.5 mm)
Spark Plug Gap	0.020 in. (0.51 mm)
Spark Plug Torque	180 lb-in. (20 Nm)
Armature Air Gap	0.005 - 0.008 in. (0.13 - 0.20 mm)
Intake Valve Clearance	0.004 - 0.006 in. (0.10 - 0.15 mm)
Exhaust Valve Clearance	0.007 - 0.009 in. (0.15 - 0.23 mm)

Oil Type	5W30 Synthetic
Oil Capacity (with filter)	78 - 80 oz. (2.3 - 2.4 L)
Engine End Cover Bolt	220 lb-in (25Nm)

Not for  
Reproduction

Not for  
Reproduction

Not for  
Reproduction