

## Product Dimensions

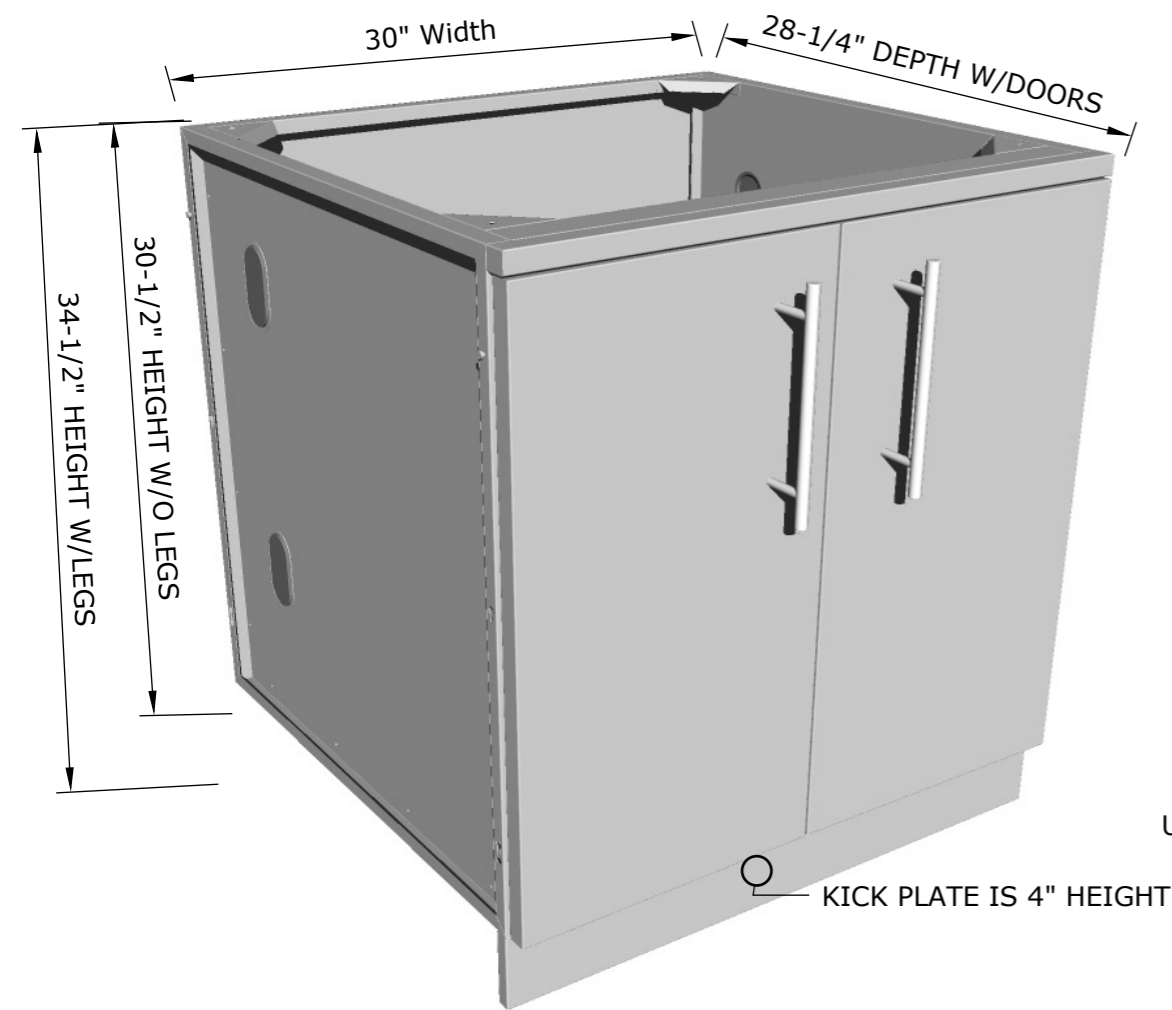

## Product Components

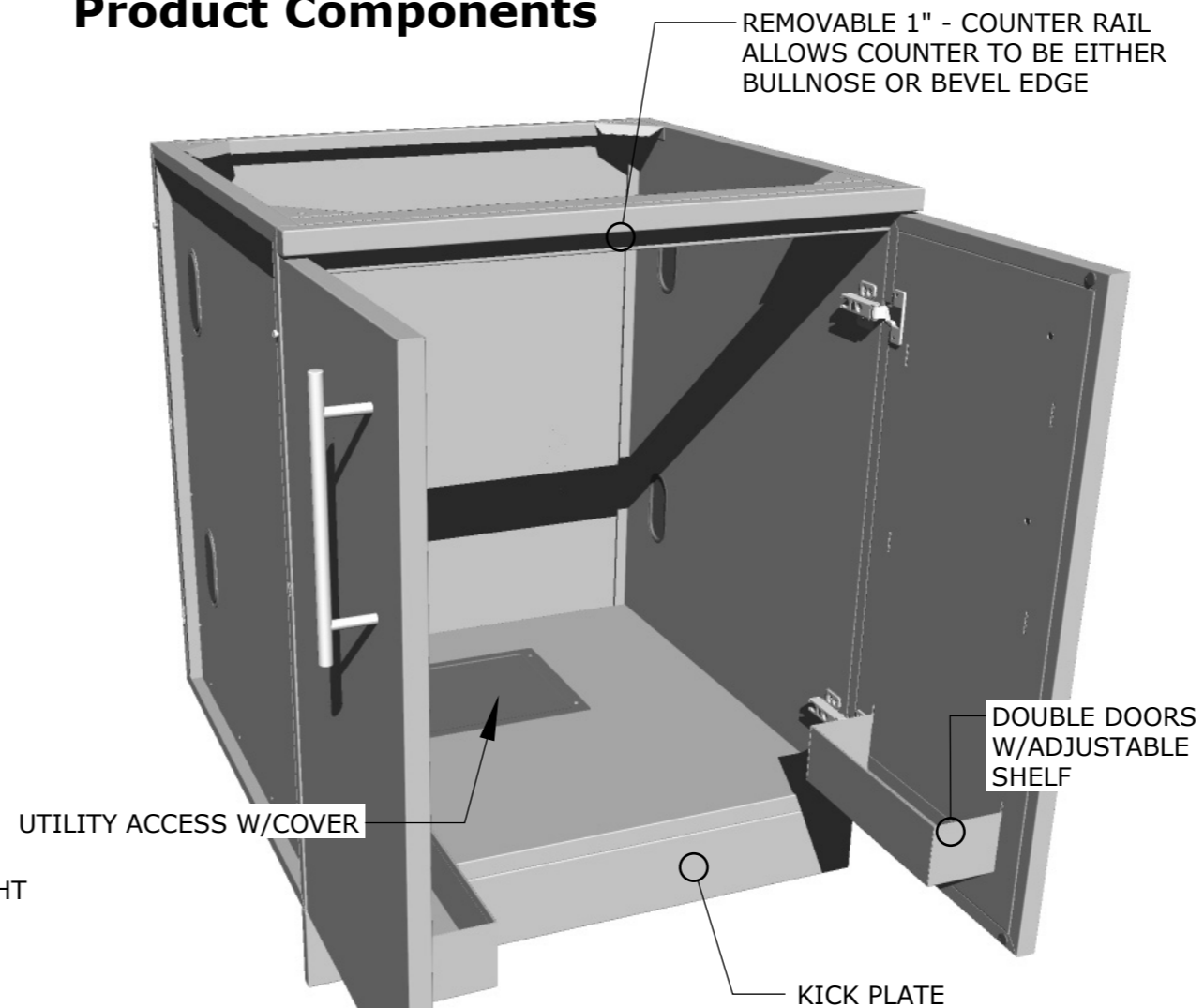

## Product Diagrams

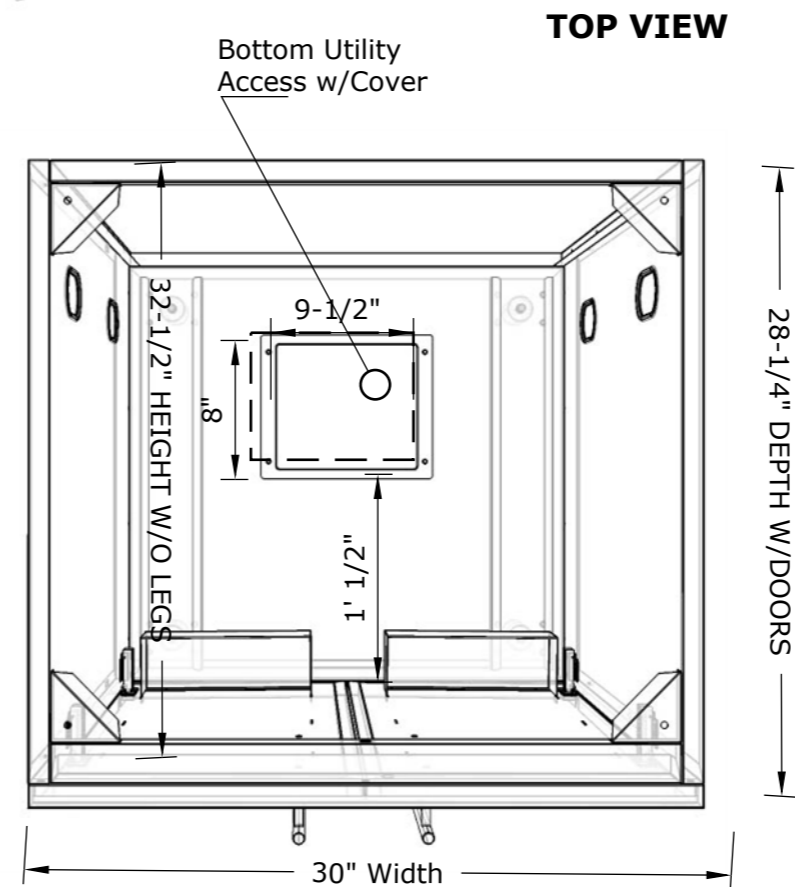
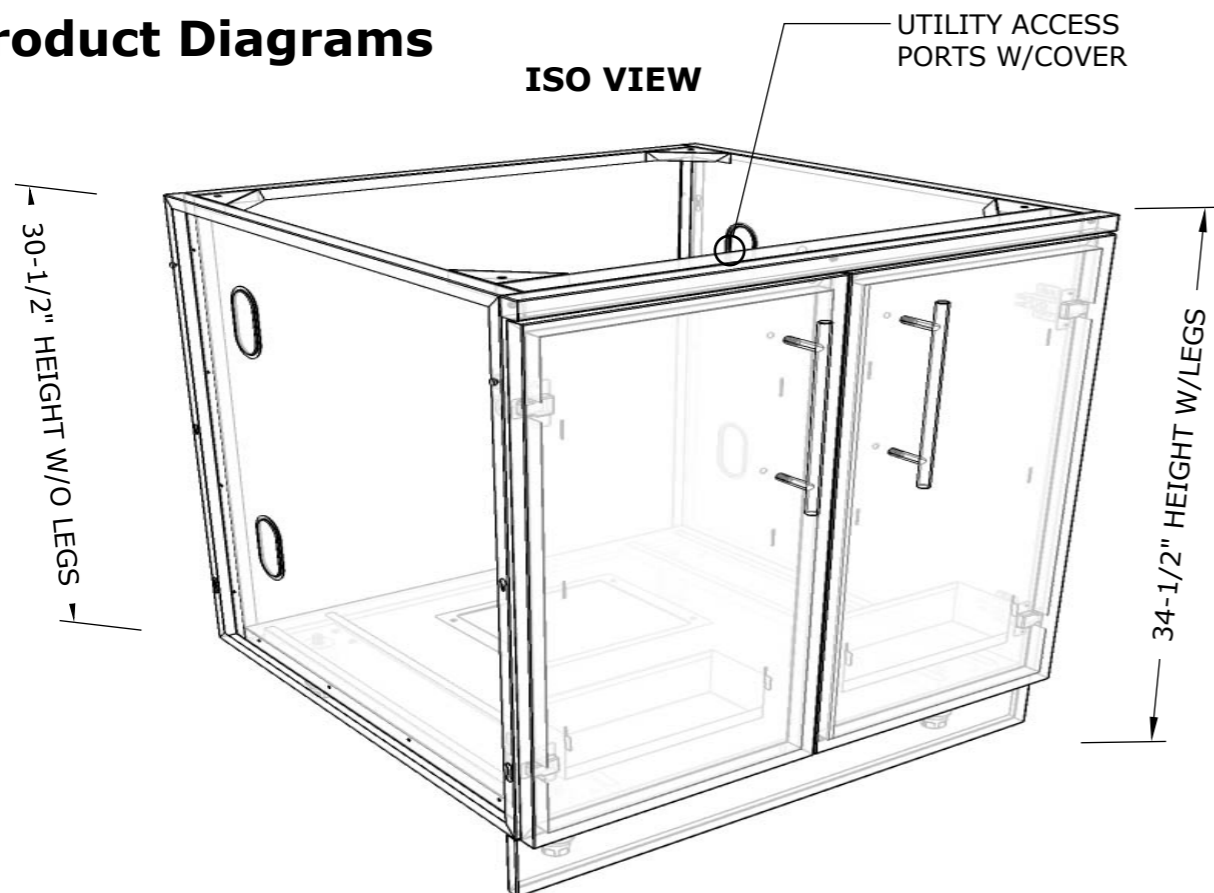

**SUNSTONE METAL PRODUCTS**  
 16004 CENTRAL COMMERCE DR.  
 PFLUGERVILLE, TEXAS 78660  
 Tel: 888.934.9449  
 Bus: 512.487.5116  
 Fax: 512.487.7016

### PRODUCT

30" Full Height Double Door Cabinet

**Item No.** SBC30FDD

### DESCRIPTION

30" Full Height Double Door Cabinet, Doors are double walled with adjustable shelf.

- Lifetime Structure Warranty
- 304 Stainless Steel Structure
- 304 SS Rod Handles
- Front & Back Kick-Plates
- Easy Pin-Lock Installation
- Soft-Close Drawer Tracks
- Covered Access Ports
- Adjustable Peg-Legs
- Optional Wheel Casters

### INCLUDED COMPONENTS

- Front Kick Plates
- Back Solid Kick Plate
- (4) Adjustable Peg Legs

### PRODUCT DIMENSIONS

30"W x 28-1/4"D (w/Doors) x 34-1/2"H (w/Legs) or 30-1/2"H (no Legs) or Upto 36" Max Adjustable Height

### INSERT DIMENSIONS

28"Width x 18"Depth

### INSERTABLE PRODUCTS

Single Side Burner - 1SSB  
 Premium Sink - B-PS21  
 Standard Sink - A-SS17  
 Drop-In Ice Chest - A-IC

### MATERIAL SPECS

304 Stainless Steel entire structure, 18 Gauge for Door Panel, 18 Gauge for Cabinet Box, 18 Gauge for Shelf, Handles are made of Solid 304 Stainless Steel Bar.