

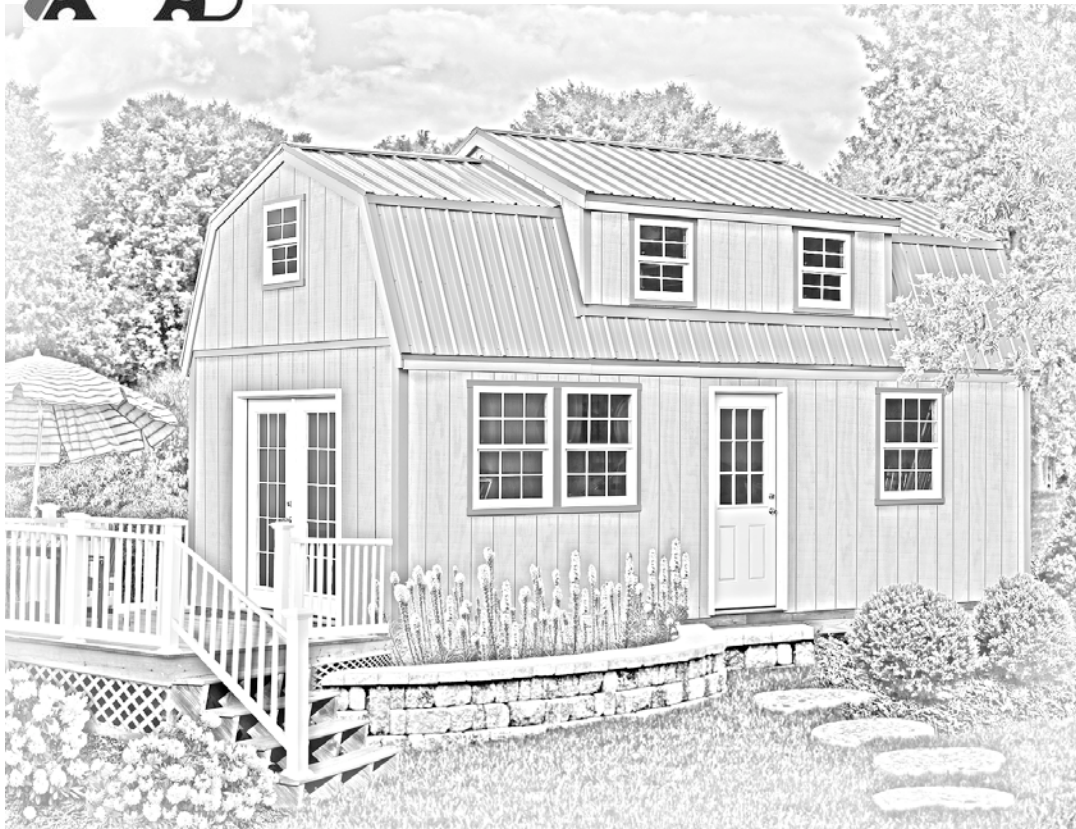

Sentry Buildings

Assembly Book

November 22 , 2017



the Lakewood

12' x 24'

Manufactured by Reynolds Building Systems, Inc.

205 Arlington Drive

Greenville, PA 16125

This manual is copyrighted. Under the copyright laws, this manual may not be copied, in whole or in part, without consent from Reynolds Building Systems, Inc. © Copyright 2017

IMPORTANT INFORMATION ABOUT YOUR SHED KIT

Download the most current instruction book at www.barnkits.com; use the "[manuals](#)" link on the menu bar and then select your building kit and size.

Material Delivery: The building materials will be delivered in (2) two shipments. The material for the lower walls and loft floor, and the optional wood floor, will be delivered by a local lumber supplier. This enables us to provide long framing lumber not easily delivered by common carrier trucks. Check to see if you received the correct amount of material before you start construction. Call our office and report any discrepancy. The material for the 2nd floor will be delivered with the kit from our factory. See the back page for the break down of both material deliveries.

Inspect All Windows: Inspect windows for damage. To get a replacement window you must report any damage by calling the number listed above within seven (7) days from date of delivery. The six (6) upper windows are shipped in the smaller pallet.

Assembly Questions: It is very important to assemble our components in the order indicated in the instructions. Read the instructions before starting the assembly of the building. If you have any questions about assembling the kit, call 800-245-1577; business hours (8:00-5:00 ET) Monday thru Friday. After business hours call 724-866-HELP (4357) or send an email to help@barnkits.com.

Multiple Design Options: There are multiple options for constructing the front and end walls, depending on window and door layout. Review each option and decide which is appropriate for your building before beginning construction.

Window/Door Placement: Four (4) dormer windows and two (2) gable windows are included in our kit. The entry door and lower windows are not included. The manual gives general instructions on installing windows and door opening in the walls. You will need to adjust the opening size if you do not use the same window make and size indicated in the manual.

Metal Roof Kit: A pre-cut metal roof kit is available with limited color selection. Go to www.shedkitstore.com for more information and price.

Extra 2x4s were built into the main shipping pallet to be used for wall bracing. Unpack the material from the pallets, then unscrew the top 2x4s. The bit for the screws is packed in the hardware bag.

Tool List

- | | |
|---|--|
| <input type="checkbox"/> Hammer & Power Screwdriver | <input type="checkbox"/> Measuring Tape & Caulking Gun |
| <input type="checkbox"/> Framing Square & Level | <input type="checkbox"/> Two 12' Step Ladders |
| <input type="checkbox"/> Hand & Circular Saw | <input type="checkbox"/> Safety Glasses & Harnesses |
| <input type="checkbox"/> Router or Jig Saw | <input type="checkbox"/> Scaffolding - <i>see note below</i> |

A nail gun is not listed on the tool list. However, because of the amount of nailing required for this building, it would save assembly time. The breakdown of nails needed is listed on the back page. You may be able to receive credit to exchange the nails at your local lumber supplier.

You will need to rent (6) six sections of scaffolding to safely install the roof trusses and sheathing. Use safety harnesses when reaching over the scaffolding. Consider hiring a professional roofer to install the shingles or metal roof. They have the knowledge and equipment to do the job properly.

Read Me First: Important Information on Building The Walls



Study the information below on assembling the wall frames and applying the siding. This information may not be repeated in the assembly steps.

Always wear safety glasses when cutting or nailing.

Pre-cut wall studs will measure 92-1/4" to 93" in length, depending on your location. Nail studs to bottom (treated) wall plates with 16d galvanized nails, and use 16d coated sinkes for top plates; (2) two nails on each end.

Square the wall frame before applying siding. Measure the wall diagonally (corner to corner), then measure the opposite corners. These measurements will be the same when the wall is square.

The siding is made in 4x8 sheets with grooves cut into the face, the long edge is beveled so that the siding overlays where they butt. To identify which edge we want you to use, we will refer to the edge as either the 'LAP' Edge or the Tongue Edge. Nail siding with 8d galvanized box nails, spaced 8" apart.

Paint the bottom edges of the siding and keep dirt, grass, mulch, snow away from the lower part of the siding. The siding manufacturer generally recommend 8" or more of clear space.

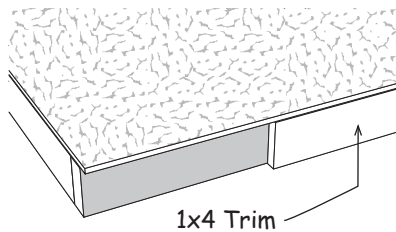
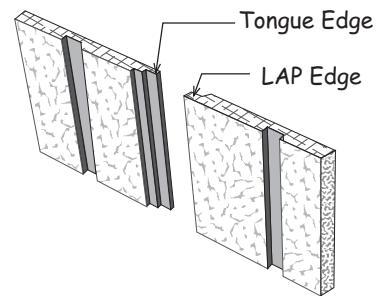
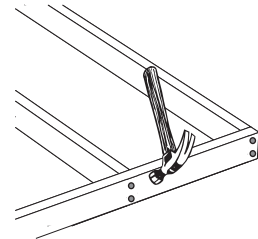

Install the siding flush with the bottom plate when installing the building on a concrete slab.

When installing the building on a wood floor the siding should extend 3/4" below the bottom plate to cover the edge of the flooring.

Tip: Use a 1x4 trim board as a gauge to extend siding the proper distance.

Our instructions show assembling the wall frames while the frames are flat on the floor. This makes it easier when squaring the walls and cutting out the window openings. However, most windows for new construction requires the windows to be installed before applying the siding. If you apply siding to the the larger walls with windows installed, the wall will be very heavy. Walls without windows or smaller walls with windows can be moved with four people.

You can precut the siding while the walls are laying flat on the floor and remove the siding before setting the walls.

Another alternative, square the wall frame and install one siding panel to hold the frame square. Install the remaining panels after the wall is set on the floor.



Tip: Insert nails partway between the wood floor sheathing and the 2x4 floor frame. Rest the siding on the nails.

Construction Details for Optional 12'x24' Floor System

Foundation size is 12'-0" x 24'-0". Check local building codes in your area, the construction may have to change.

1. Cut (20) twenty 2x4-12' treated boards to 11' 8-7/8". These will be the floor joists.
2. Cut (2) two 2x4-12' treated boards into 3' long blocks to secure the 4x4s where they butt together. Secure the blocks to the 4x4s with 16d galvanized deck nails.

3. Cut (2) two 2x4-12' treated boards to a length of 12'-0"; they will be used for the joist headers. Layout, from left, for 16" on center joist spacing. 'X' marks where floor joist will be placed.

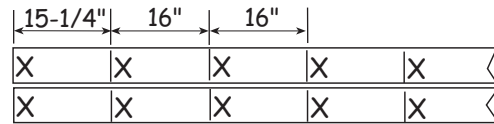

4. Install the floor joists cut above between the 12' joist headers. Secure with 16d galvanized deck nails. Build (2) two floor sections measuring 12' x 12'.
5. Place a floor assembly over the 4x4s. Square floor assembly by measuring the floor diagonally (corner to corner), then measure the opposite corners. The measurements will be equal when the floor is square. Toenail the frame to the 4x4s to keep it from moving. Install the second floor section.

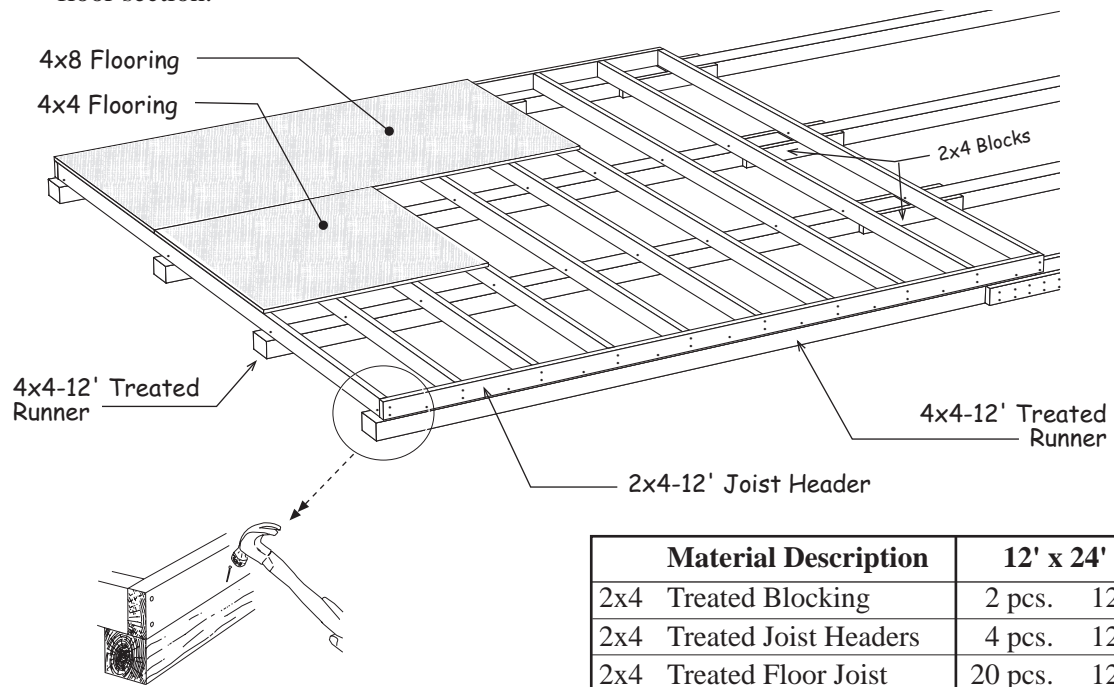

6. Install 4x8 flooring over the 2x4 floor using 8d galvanized spiral floor nails spaced 8" apart.

Material Description	12' x 24'
2x4 Treated Blocking	2 pcs. 12'
2x4 Treated Joist Headers	4 pcs. 12'
2x4 Treated Floor Joist	20 pcs. 12'
4x4 Treated Runners	8 pcs. 12'
Flooring 3/4"	9 pcs. 4x8
Galv. Spiral Floor Nails	5 lb. 8d
Galvanized Deck Nails	5 lb. 16d

Step 1 Assemble (2) Two Dormer Trusses



Building Tip: To aid in the assembly of the trusses, temporarily tack 1x4 blocks to the floor. There are short 1x4s supplied in the kit for this purpose. This will trap the truss parts and ensures the other truss will be assembled the same.

1. Assemble a dormer truss using (2) two 78-3/4" long 2x6 rafters, (1) one 95-3/4" long 2x4 with angle cuts on the ends, and a pre-built saddle. There should be 140" between the notch in the 2x6s. Hold parts in place with 1x4 blocks. Secure the 95-3/4" long 2x4 with (2) two 2-1/2" deck screws.

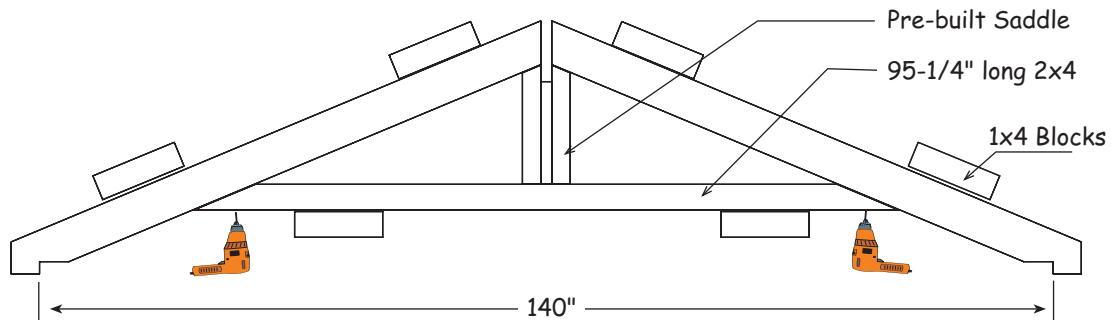

2. Install pre-cut OSB gussets over the dormer truss parts to secure them in place. Apply wood glue between the framing and OSB gussets. Attach gussets with (2) two rows of 6d common nails spaced 6" apart.
3. Remove the siding that covers the slot in the saddle. This will allow the ridge beam to extend through the truss.

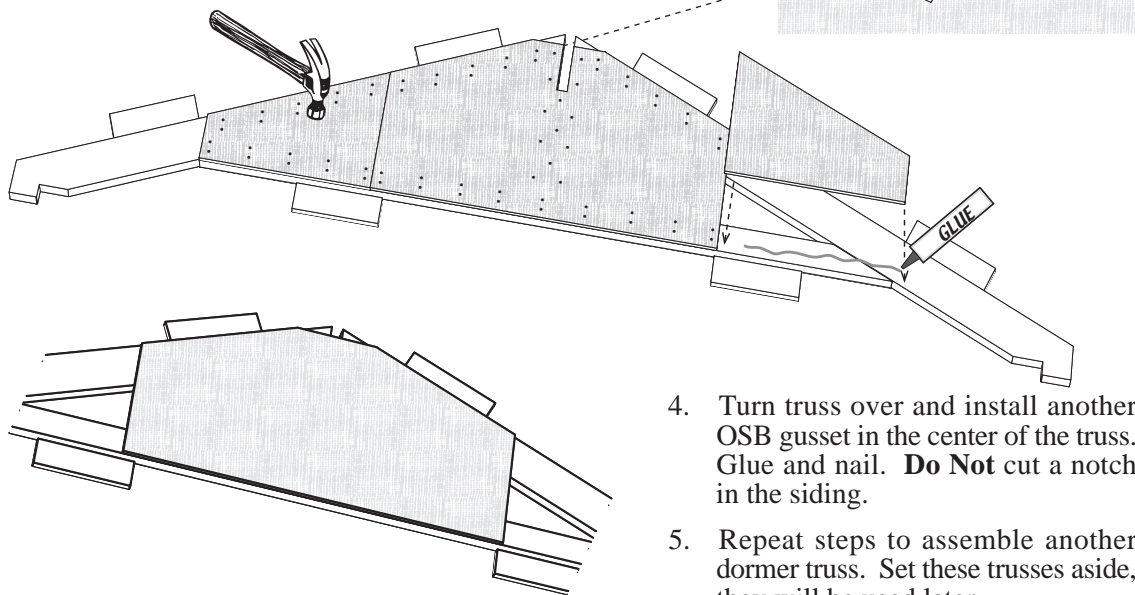

4. Turn truss over and install another OSB gusset in the center of the truss. Glue and nail. **Do Not** cut a notch in the siding.
5. Repeat steps to assemble another dormer truss. Set these trusses aside, they will be used later.



The length of pre-cut studs will vary from 92-1/4" to 93" depending on what part of the county you are located. The length does not matter in assembling the walls.

If you want to install windows or a patio door in the end walls, review the 'General Window Instructions' on the next page and go to **Step 3A** for instructions on building the wall frame with windows or **Step 3B** for an end wall frame with a patio door.

IMPORTANT: Only build (2) two 12' end wall frames.

Step 2 Assemble 12' End Wall - Without Windows

1. Framing lumber may not be the exact length. If necessary cut (1) one treated 2x4-12' and (1) one untreated 2x4-12' to a length of 12'-0" (or 144"). Position the boards together and indicate with 'X' marks where the wall studs will be located.

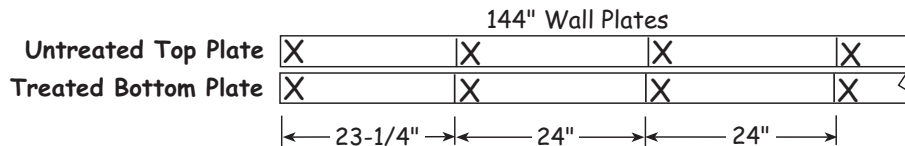

2. Install (7) seven pre-cut wall studs between the top & bottom plates. Nail studs to wall plates with 16d galvanized nails for the treated bottom plate and 16d coated sinker nails for the untreated top plate; (2) two nails on each stud end.

144" Untreated Wall Plate

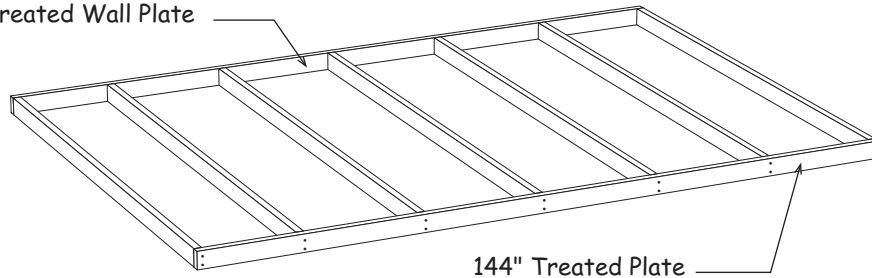

3. Square the wall frame. Install the first siding panel with the 'LAP' edge flush with the end of the wall and nail siding with 8d galvanized box nails spaced 8" apart.
4. Install (2) two more siding panels.

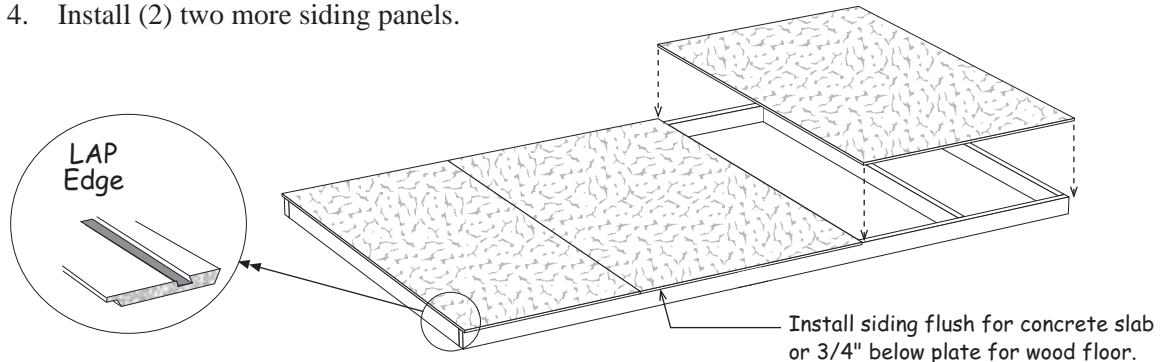

5. Repeat this step if you do not want windows in the second end wall, otherwise review the 'General Window Instructions' and then follow **Step 3A** or **3B** to build a second end wall.

General Window Instructions



The instructions below shows how to assemble window and/or door headers and frame in window openings. There are extra pre-cut 2x4 wall studs, 2x6 boards and 7/16" OSB fillers provided for this. Additional filler strips can be cut from the 4'x7' OSB cover sheet on the main pallet (you will need a 4'x4' section of the cover sheet for **Step 20**). Sample door and windows opening are shown for reference. Adjust the opening sizes to fit the windows and doors you purchase.

1. Assemble window or door headers by cutting 2x4 pre-cut wall studs or 2x6 boards . Cut OSB fillers from material supplied in our kit. Headers should be made 3" longer than the window or door rough opening measurements.
2. Assemble a window header using wood glue and 10d coated sinker nails, nailing both sides.
3. Cut 2x4 pre-cut wall studs to construct a window frame.

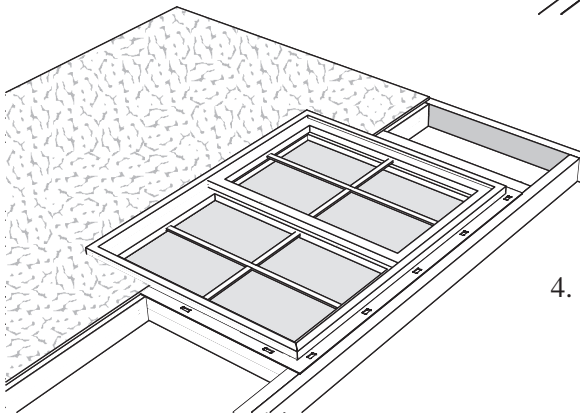
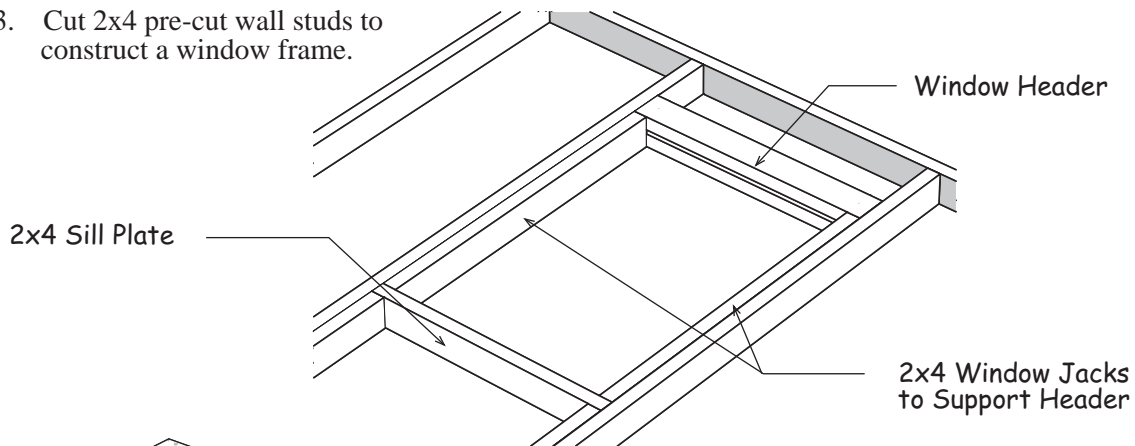
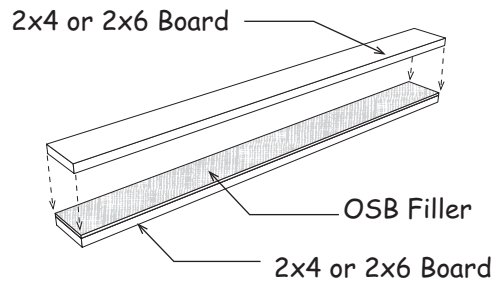

4. Install window following the manufacturer's instructions. Cut exterior siding to fit around the window.

Step 3A Assemble 12' End Wall With Two Windows

 This layout shows assembling an end wall using a 24"x36" Jeld-Wen (V-2500 Series) single hung window. ThermaStar, by Palla, makes a similar window; their window is 24"x38". Adjust the opening size to the window header and framing around the window opening.

1. Cut (1) one treated 2x4-12' and (1) one untreated 2x4-12' to a length of 144" and install (7) seven 2x4 pre-cut wall studs between the boards where shown, using 16d galvanized nails for the bottom plate and 16d coated sinker nails for the top plate.
2. Assemble 2x4 window headers using pre-cut studs. Headers should be 3" longer than the rough opening width for the window.
3. Cut pre-cut wall studs to frame in the window openings.
4. Assemble the window opening using the above parts and using 10d coated sinker nails.

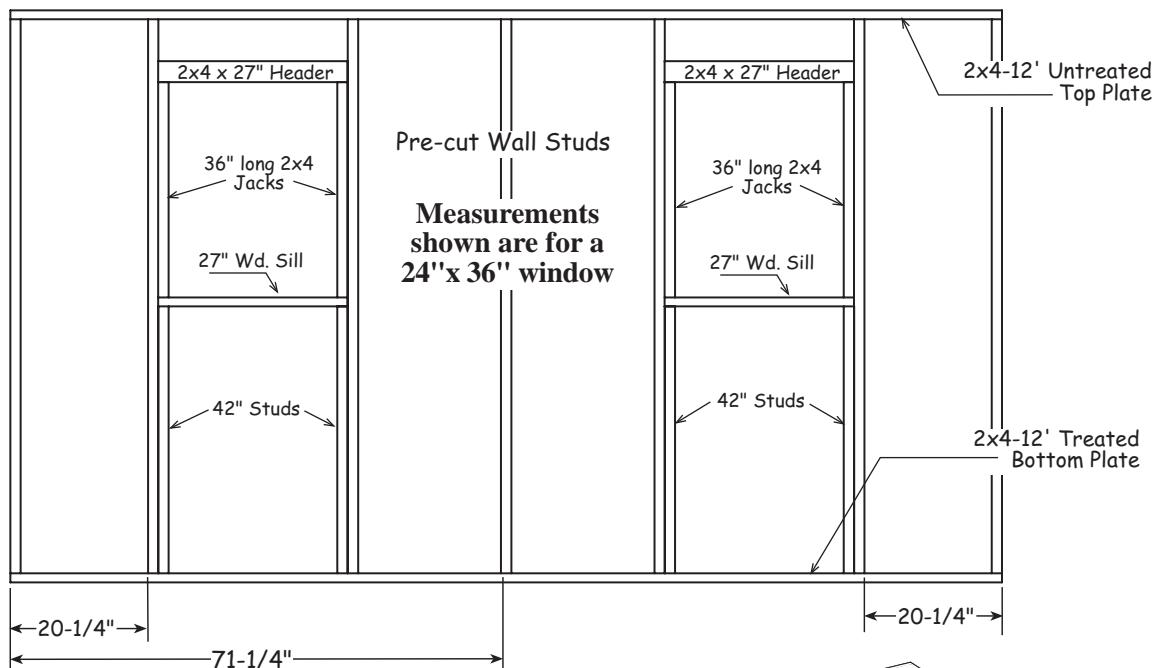

5. Pre-cut (3) three siding panels. It is recommended to install the windows and siding after the wall frame is installed on the floor.

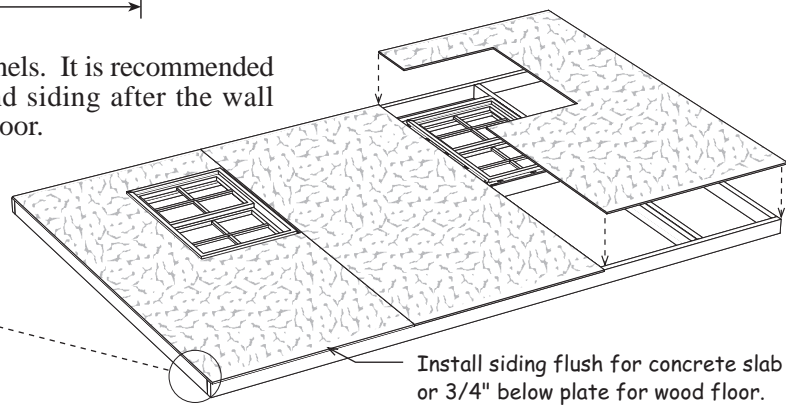
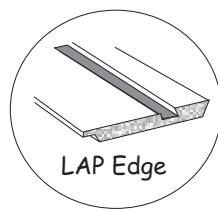

Step 3B Assemble 12' End Wall - With Patio Door



The instructions below shows how to assemble a wall for a 6' patio door.
Adjust the opening size for other types and sizes of entry doors.

1. Cut (1) one treated 2x4-12' and (1) one untreated 2x4-12' to a length of 12'-0" (or 144"). Install (6) six pre-cut wall studs between the boards where shown in drawing below using 16d galvanized nails for the bottom plate and 16d coated sinker nails for the top plate.
2. Cut (2) two pre-cut wall studs to 78-1/2" and install on each side of the door opening using 10d coated sinker nails.
3. Cut (2) two 2x6-8' boards to 75". Assemble a door header using these boards and a OSB filler supplied in our kit. Install the header using 10d coated sinker nails toenailed to the studs.

4. Cut 2x4 blocks and install above the door header.

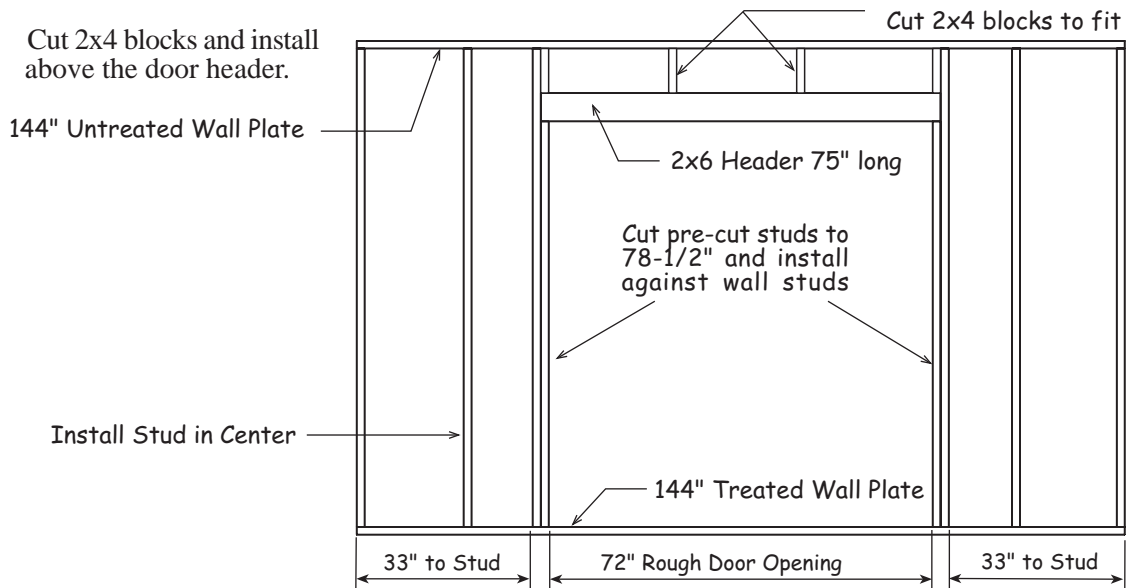

5. Install a 4x8 siding panel on the left side of the wall panel using 8d galvanized box nails spaced 8" apart. Before you install the siding, cut and remove the siding that extends into the door opening.

6. Cut and install a siding panel above the door opening.

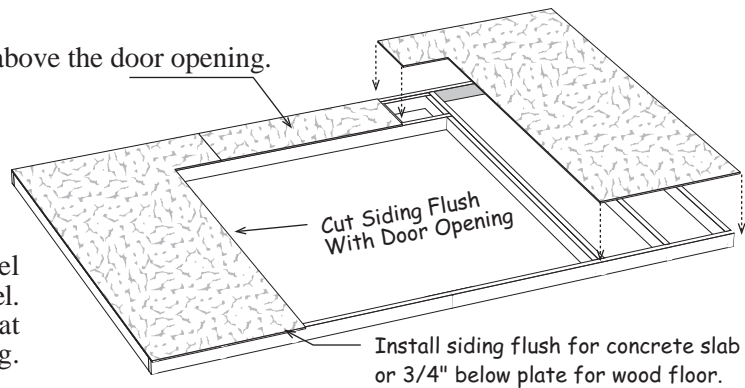

7. Install another 4x8 siding panel on the right side of the wall panel. Cut and remove the siding that extends into the door opening.

Step 4 Assemble 140-1/2" Long Back Wall

1. Cut (1) one treated 2x4-12' and (1) one untreated 2x4-12' to a length of 140-1/2". Position the boards together and indicate with 'X' marks, where the wall studs will be located.

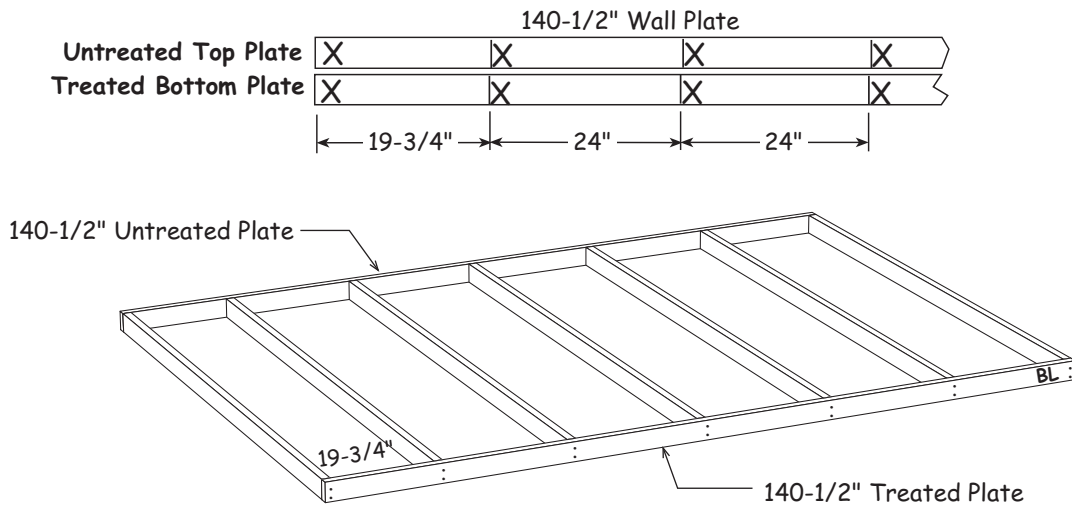

2. Install pre-cut wall studs between the top and bottom plates using 16d galvanized nails for the treated bottom plate and 16d coated sinker nails for the top plate. Mark this panel as 'BL'.
3. Square the wall frame. Install the first siding panel with the 'LAP edge' extending 3-1/2" beyond the end of the wall. Secure using 8d galvanized box nails spaced 8" apart.
4. Install (2) two more siding panels.

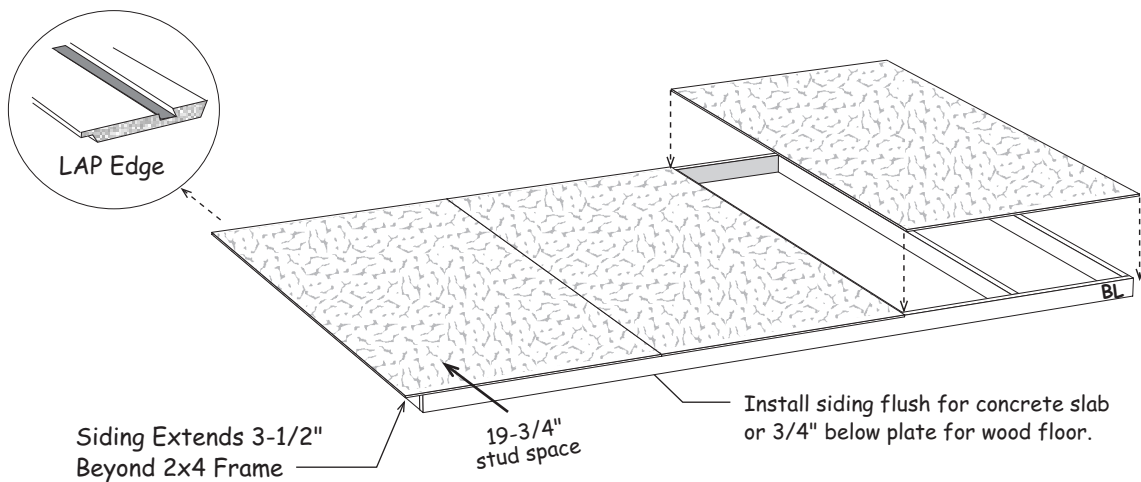

Step 5 Assemble Another 140-1/2" Long Back Wall

1. Cut (1) one treated 2x4-12' and (1) one untreated 2x4-12' to a length of 140-1/2". Position the boards together and indicate with 'X' marks, where the wall studs will be located.

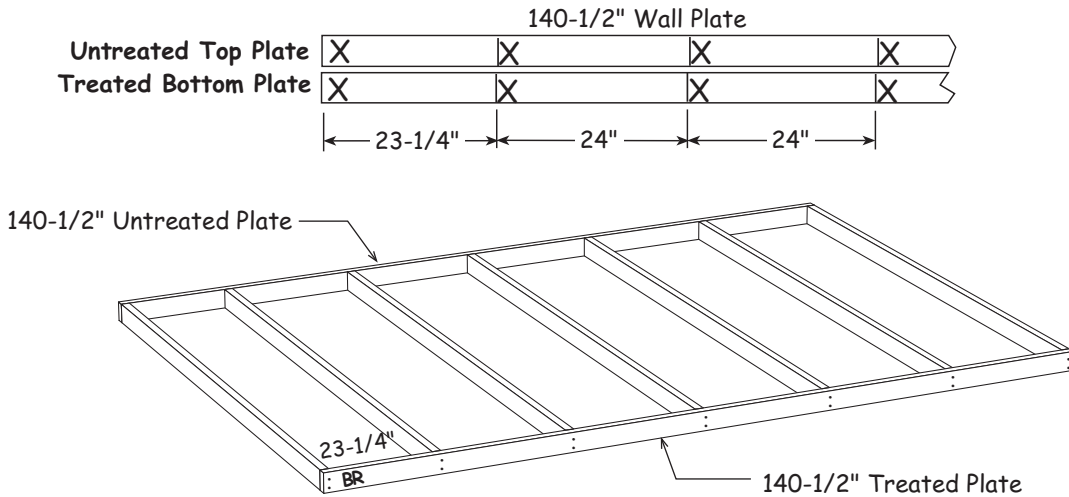

2. Install pre-cut wall studs between the top and bottom plates using 16d galvanized nails for the treated bottom plate and 16d coated sinker nails for the top plate. Mark this panel as 'BR'.
3. Butt the above wall frame against the 'BL' wall panel from **Step 4**. **Do Not** nail the frames together so that they can be separated later.
4. Square the wall frame and install a siding panel. **Do Not** nail the long edge that overlaps the siding on the adjoining panel so they can be separated. Install (2) two more siding panels; the last panel will extend 3-1/2" past the wall frame. Separate wall panels.

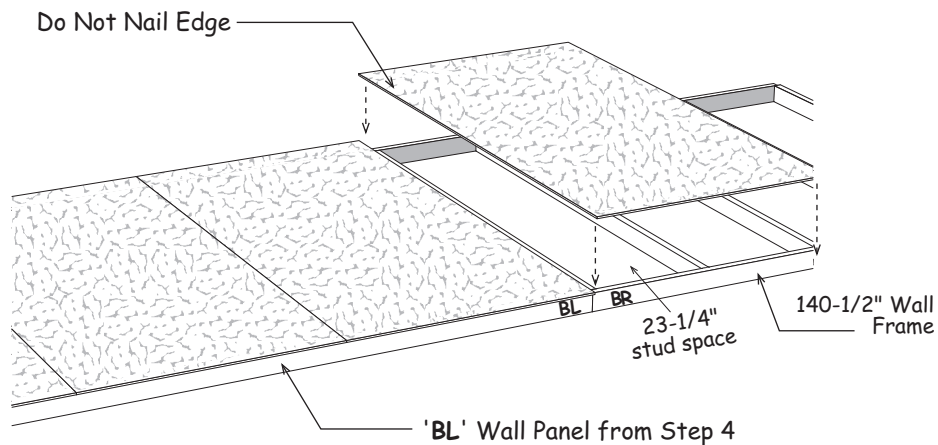

Step 6 Build Front Walls with Walk-in Door Opening



The instructions below shows how to assemble a wall for a 2/8x6/8 door. Adjust the opening size for other types and sizes of entry doors.

1. Cut (1) one treated 2x4-8' and (1) one untreated 2x4-8' to a length of 96"
2. Install (6) six pre-cut wall studs, *colored gray in the drawing*, between the 8' long 2x4s using 16d galvanized (bottom plate) and 16d coated sinker nails (top plate).
3. Cut (2) two pre-cut studs to a length of 80-1/2". Install them against the center wall studs using 10d coated sinker nails
4. Cut (2) two 2x4 boards to a length of 37-1/2" and assemble a door header using these boards and an OSB filler supplied in the kit. Install the header using 10d coated sinker nails toenailed to the adjacent studs.
5. Cut 2x4 blocks to fit and install between the door header and top plate using 10d coated sinkers.

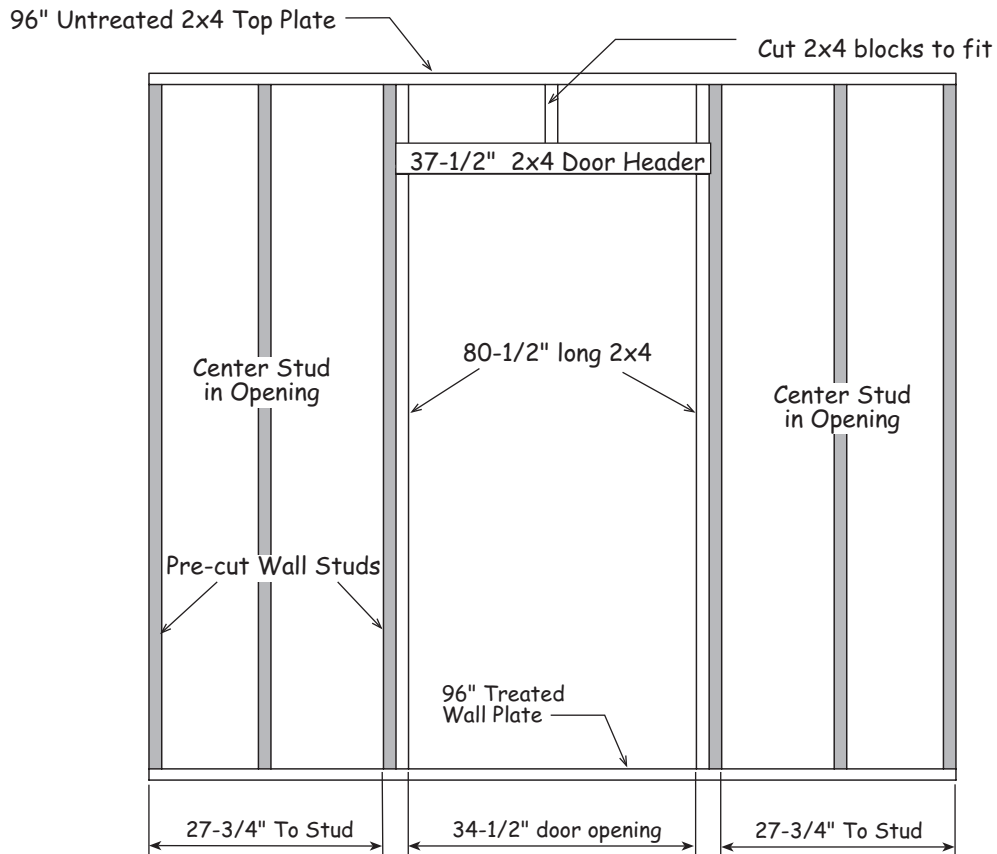

Step 7 Build Front Walls with Window Opening



The instructions below shows how to assemble a wall for a 32" x 41" Jeld-Wen (V-2500 Series) single hung window. Adjust the opening size and corresponding changes to the window header and framing around the window opening.

1. Cut (2) two treated 2x4-8' and (2) two untreated 2x4-8' to a length of 92-1/2".
2. Install pre-cut studs, *colored gray in drawing below*, between the top and bottom plates using 16d galvanized nails for the treated bottom plate and 16d coated sinkers for the top plate.
3. Assemble 2x4 window headers using 2x4 pre-cut studs and OSB filler strips. Headers should be 3" longer than the rough opening width.
4. Cut pre-cut wall studs to frame in the window openings using 10d coated sinker nails.

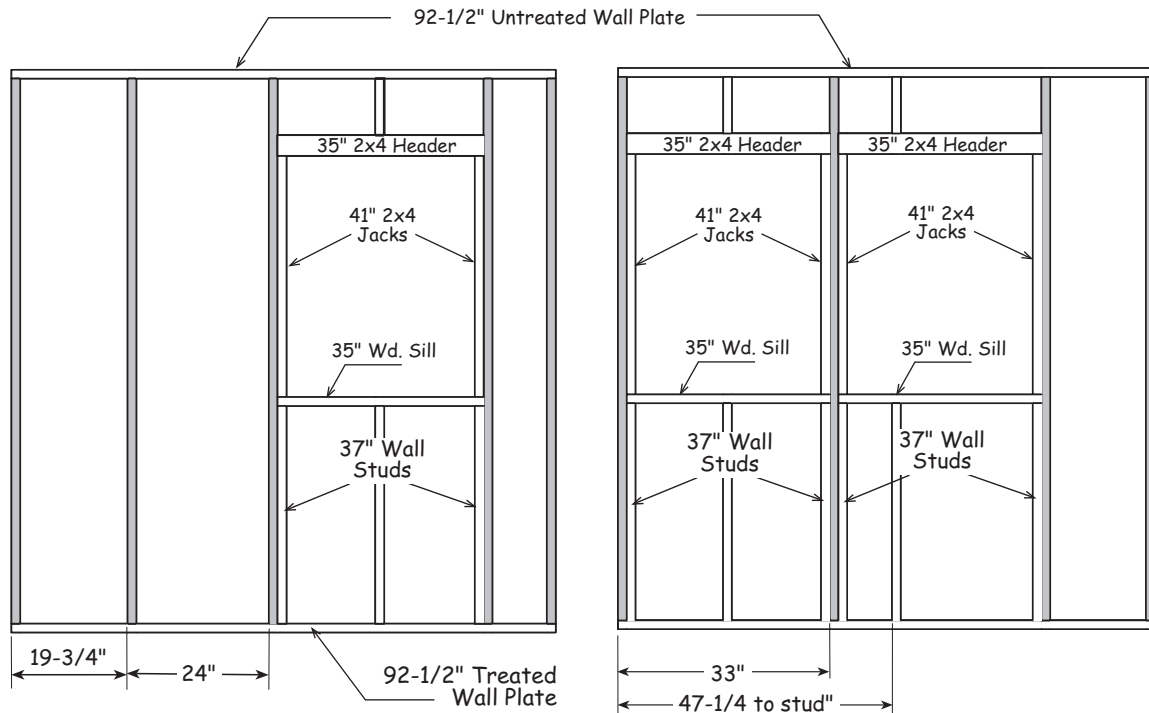

Step 8A Apply Front Wall Siding (Twin Window on Right)



Decide where you want the twin windows located; on the right, see cover photo, or on the left end of the building. To place the twin window located to the right follow the instructions below. If you want the twin window on the left go to **Step 8B**.

1. Select the wall frame with the single window opening and butt it against the center wall frame. **Do Not** fasten the frames together so they can be separated after the siding is applied. This will make setting the walls easier and assures the siding matches where the walls meet.
2. Install the window. Install a siding panel with the LAP edge extending 3-1/2" past the left end of the wall frame using 8d galvanized box nails spaced 8" apart. Cut siding around window and install siding panel.
3. Install (2) two siding panels on the center wall frame. **Do Not** nail along the edge that joins the left wall panel so the wall can be separated.
4. Cut out for the door opening.

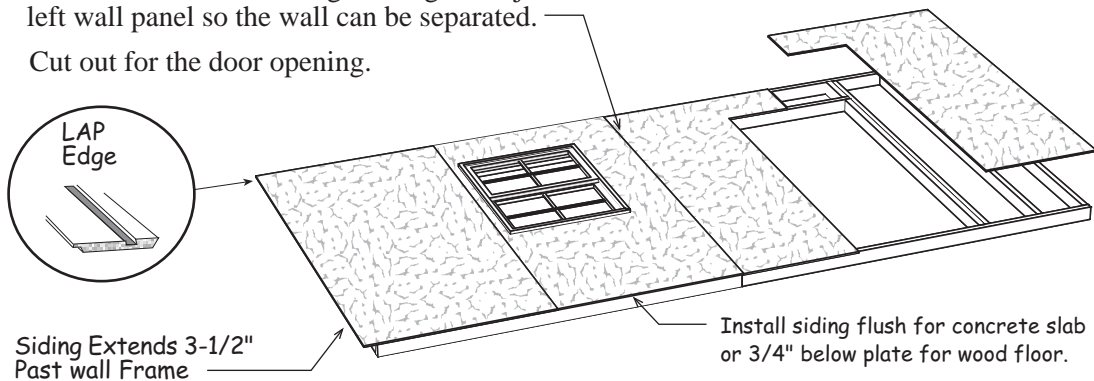

6. Butt the remaining wall frame against the 8' center wall. **Do Not** nail frames together.
7. Install the windows. Install a siding panel, removing siding around the window. **Do Not** nail along the long edge that overlaps the 8' center wall panel. You can nail this edge after the wall panels are installed.
8. Install the last siding panel, it will extend 3-1/2" past the end of the wall frame. Cut out siding in the window opening.

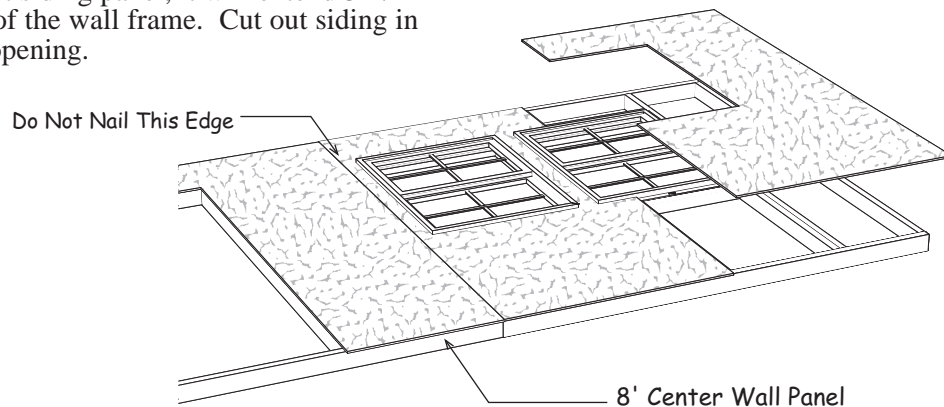

Step 8B Apply Front Wall Siding (Twin Window on Left)

1. Select the wall frame with the twin window openings and butt it against the center wall frame. **Do Not** fasten the frames together so they can be separated after the siding is applied. This will make setting the walls easier and assures the siding matches where the walls meet.
2. Install the windows. Install a siding panel with the LAP edge extending 3-1/2" past the left end of the wall frame using 8d galvanized box nails spaced 8" apart. Cut siding around window. Install another siding panel.
4. Install (2) two siding panels on the center wall frame. **Do Not** nail along the edge that joins the left wall panel so the wall can be separated.

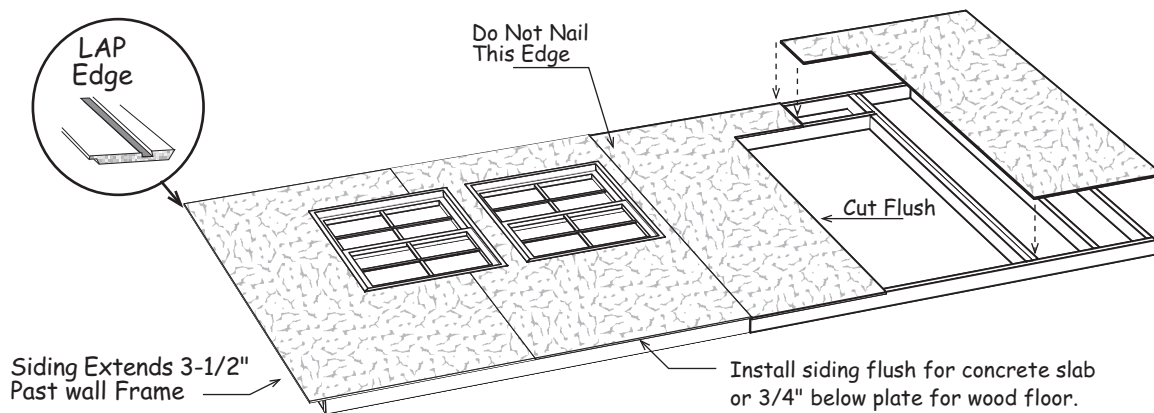

6. Butt the remaining window wall frame against the 8' center wall. **Do Not** nail these frames together so they can be separated later.
7. Square the wall frame. Install a siding panel but **Do Not** nail along the long edge that overlaps the 8' wall panel. You can nail this edge after the wall panels are installed. Cut out siding from the window opening.
8. Install the last siding panel, it will extend 3-1/2" past the end of the wall frame.

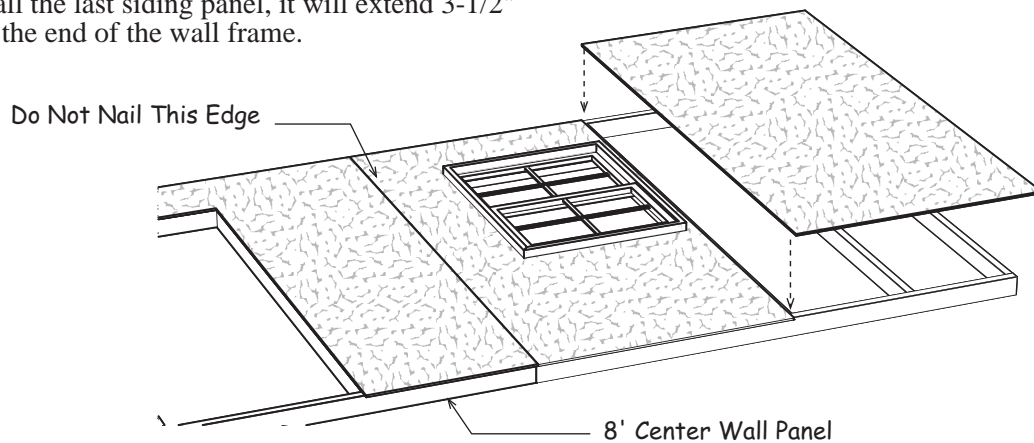

Step 9 Set Back & End Walls

1. Select the back wall panel marked 'BL' and one of the end wall panels. Install these panels at the back corner. Secure wall panels together at the corners using (5) five 10d coated sinker nails. Nail wall panels to the floor using 16d galvanized nails in every stud opening.

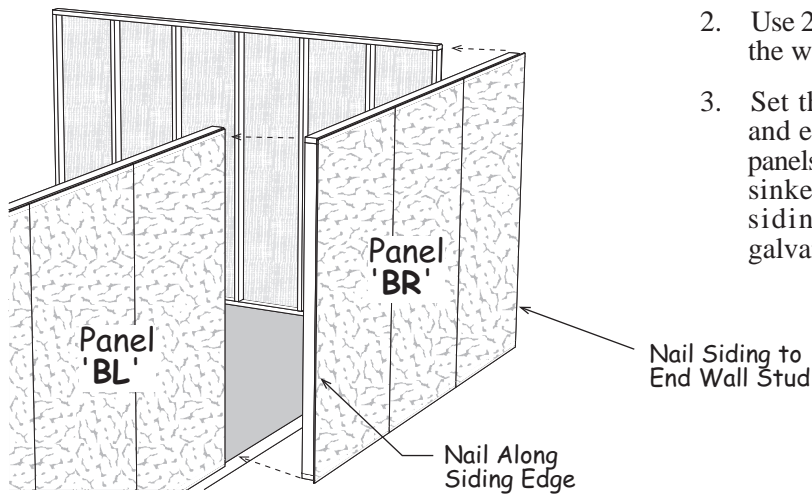

2. Use 2x4s from the pallet to hold the wall straight.
3. Set the other back wall panel and end wall panel. Nail wall panels together using 10d coated sinker nails. Nail where the siding overlaps using 8d galvanized box nails.

4. Nail along the siding edge where the back wall panels overlap using 8d galv. box nails.
5. Set the front wall panels. Nail along the siding edge where the side wall panels overlap.
6. Cut and remove the bottom 2x4 in the door openings.

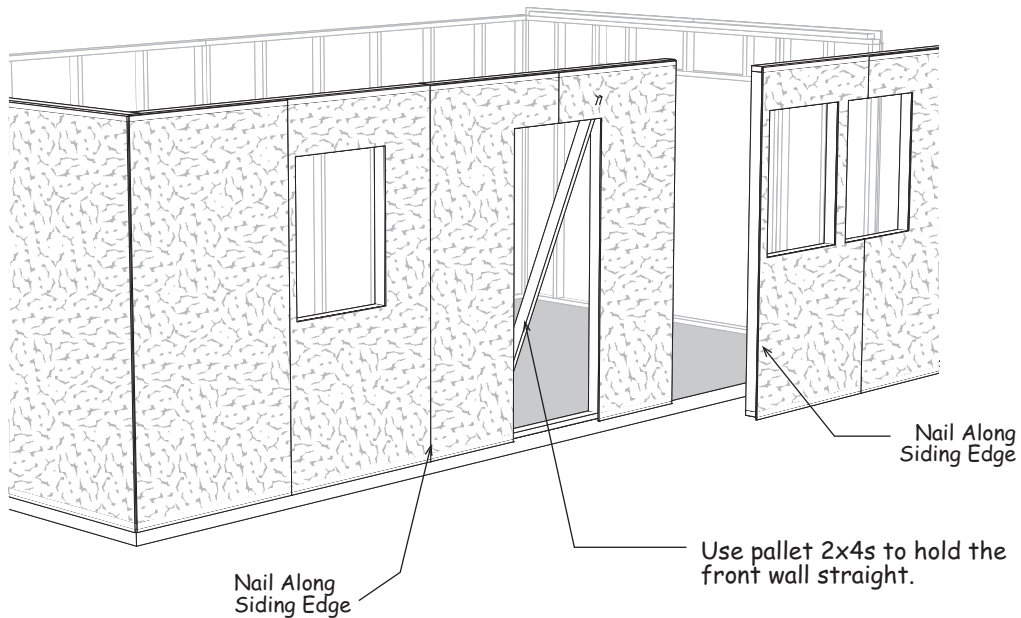

Step 10 Install 2x4 Tie Plates

1. Cut a 2x4-12' in half and install a 6' long 2x4 flush with the 2x4 top plate on the front wall panel. Use 10d coated sinker nails, double row, spaced 18" apart. Install a 2x4-12' board next, and then install the other 6' long 2x4 flush with the right corner. Repeat to install 2x4s across the top of the back wall.
2. Cut a 12' long 2x4 to 137". Install on the end wall. Repeat on the opposite end wall.

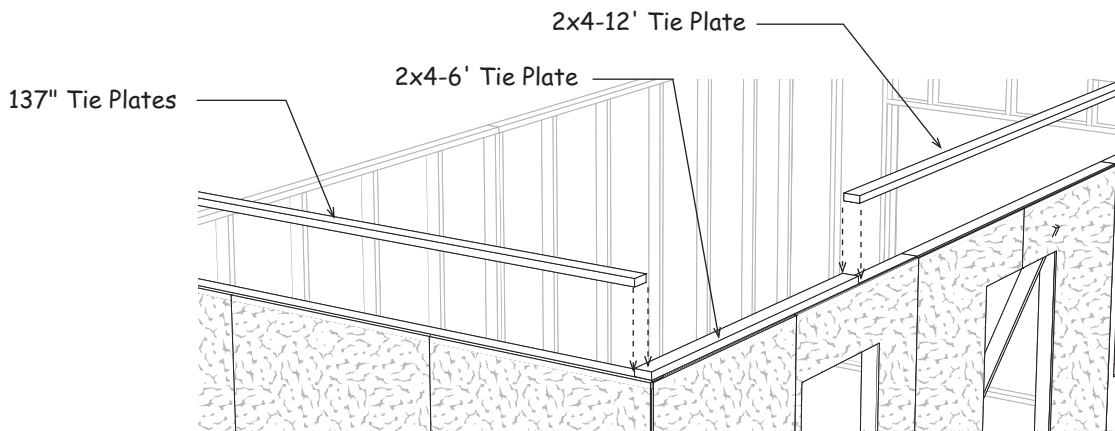

Step 11 Loft Flooring Layout

The diagram below show the loft sheathing layout with the open area position on the right. Draw a line to mark the center of the loft floor.

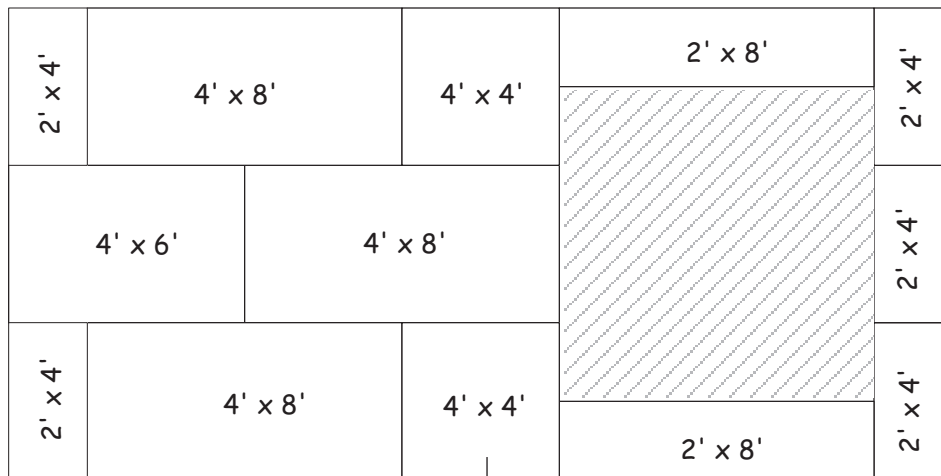

For reference later, draw a line in the center of the floor.

Step 12 Install 2x6 Joist Headers & Floor Joist



Material is provided for a 12'x14' loft over one end of the building. The instructions below will place the loft on the left end, see **Step 11** for diagram. If you want the loft on the right end start installing floor joist on the right end of the building.

1. Cut (4) two 2x6-12' boards to a length of 140-1/2". Install these 2x6 boards to the inside of front and back walls on the building, flush with the 2x4 tie plate. Secure with 16d coated sinkers nailing to the tie plate, the wall plate, and wall studs, as shown below.
2. Cut (12) twelve 2x6-12' boards to 134". Install one of the boards against the end wall.
3. Mark the joist header where the floor joist will be installed. The first floor joist will be 23-1/4" from the outside edge of the 2x4 wall plate. Mark the header for (8) eight more floor joist spaced 16" apart. Repeat to mark the joist spacing on the front wall header board. **Important:** On the front wall, make sure you put the 'X' on the left side of the line.

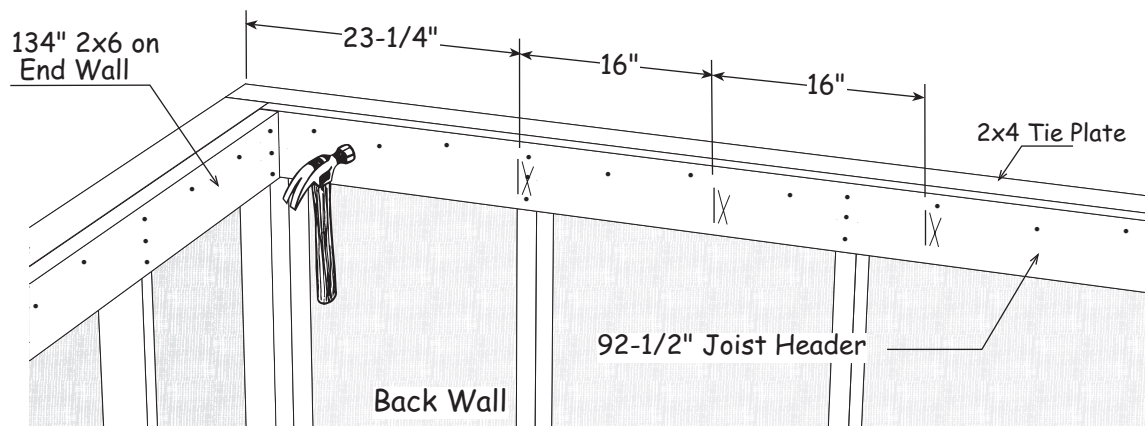

4. Install (9) nine 2x6 floor joist, using metal joist hangers, over the 'X' marks. Install metal hangers with 10d coated sinker nails.

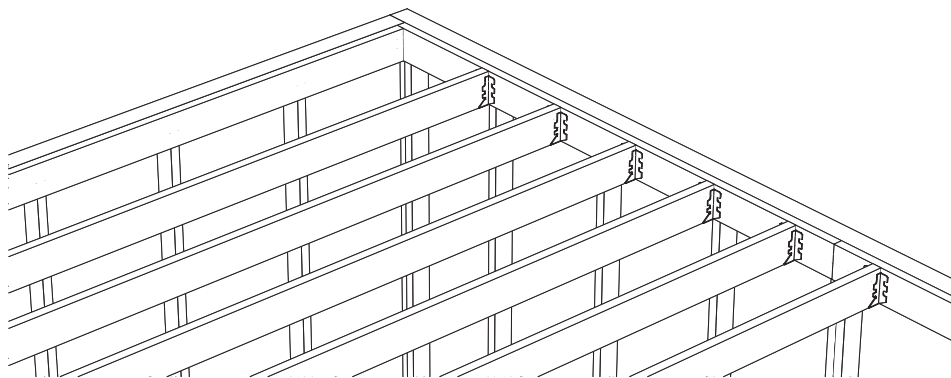

Step 13 Install Double 2x6 Joists

1. Nail the last (2) two 134" long 2x6 boards together with 10d coated sinker nails, double row spaced 16" apart. Install this double floor joist using a double joist hanger; see drawing below.

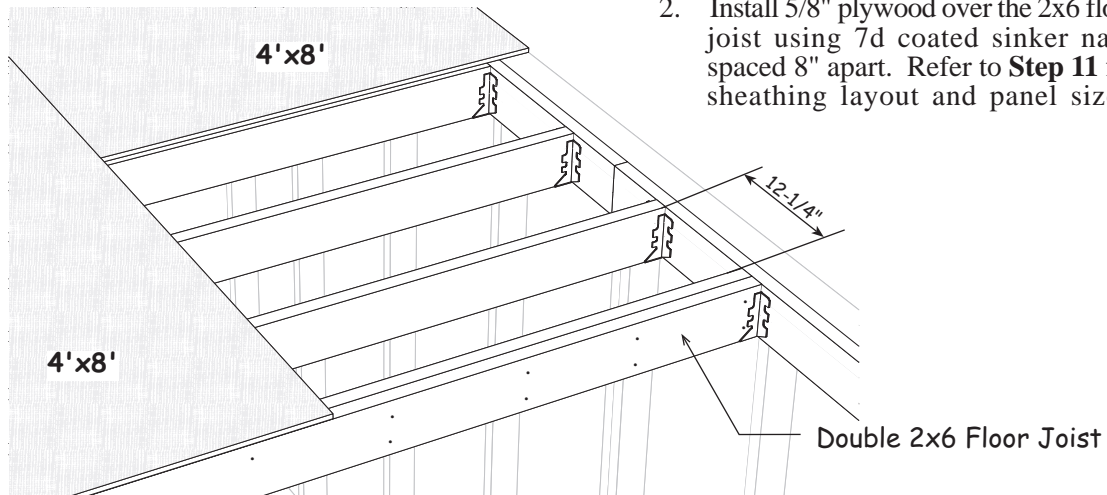

2. Install 5/8" plywood over the 2x6 floor joist using 7d coated sinker nails spaced 8" apart. Refer to **Step 11** for sheathing layout and panel sizes.

Step 14 Install Loft Shelf on 12' End Wall

1. Cut (2) two 2x6-12' floor joist to a length of 134". Nail (1) one 2x6 across the end wall using 16d coated sinker nails.
2. Using (2) two metal joist hangers, install the other floor joist with a 17-1/2" space between the 2x6s. Cut (5) five 17-1/2" long 2x4 blocks, *from wall bracing or pallet material or leftover cut-offs*, and install the blocks between these 2x6 floor joist. Use 10d coated sinkers to toenail blocks into the 2x6s.
3. Using the 4x6 sheet left over from the larger floor section, cut and install 2'x4' flooring over this shelf ledge using 7d coated sinker nails.

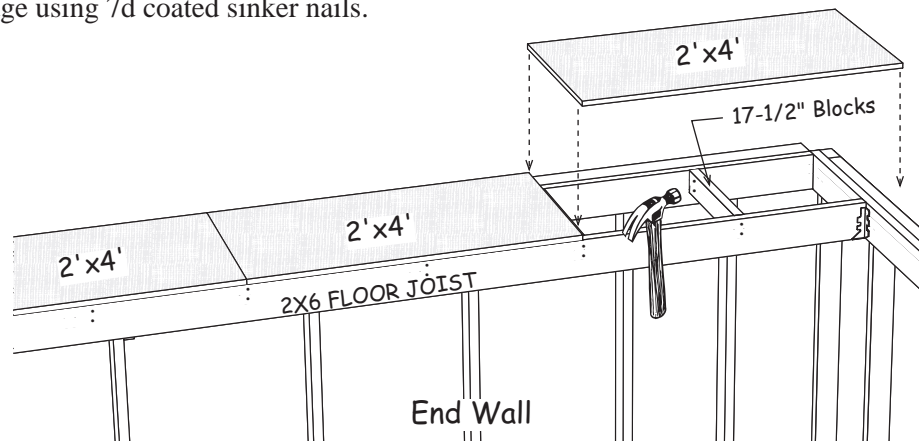

Step 15 Install Loft Shelf on 12' Back Wall

1. Install a 2x6-8' board between the loft floor and the ledge on the end wall. Cut and install (2) two 17-1/2" long 2x4 blocks between this 2x6 and joist header.
2. Cut a 4'x8' floor panel in half lengthwise creating (2) two 2'x8' panels. Install one over the loft shelf using 7d coated sinkers.

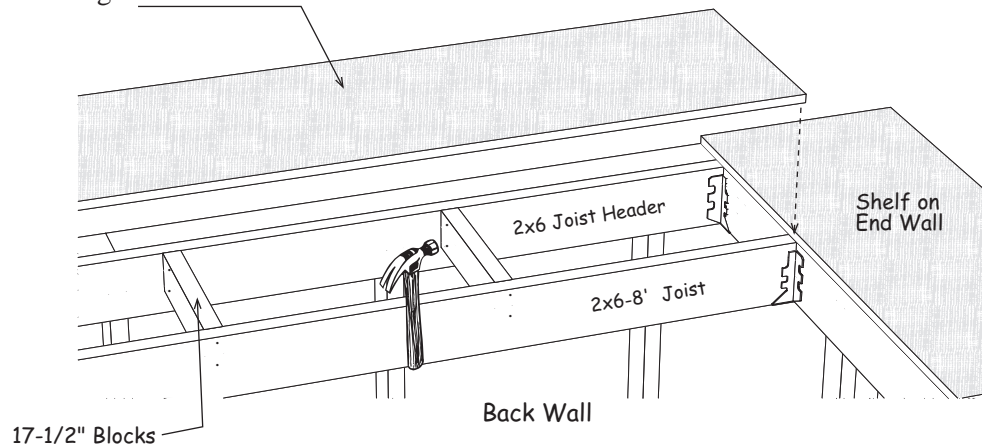

3. Install another ledge on the front of the building.

Step 16 Install End Wall Trim

IMPORTANT: End Wall Trim Must Be Installed Before Installing Roof Gables!

1. Tack 2-1/2" x 48-3/4" filler strips on both 12' end walls, flush with the loft flooring using 6d common nails spaced 24" apart.
2. Install (2) two 72" long 1x4 white pine trim boards flush with the top of the loft flooring. The trim will not be flush with the siding on the front and back walls. Use 8d galvanized box nails, double row, spaced 16" apart nails.
3. Cut 96" long 1x4 trim boards to length and install as corner trim to the end walls. Install trim flush with the siding on the front and back walls. Use 8d galvanized nails, double row, spaced 16" apart.
4. Repeat to install trim boards to the other end wall panel.

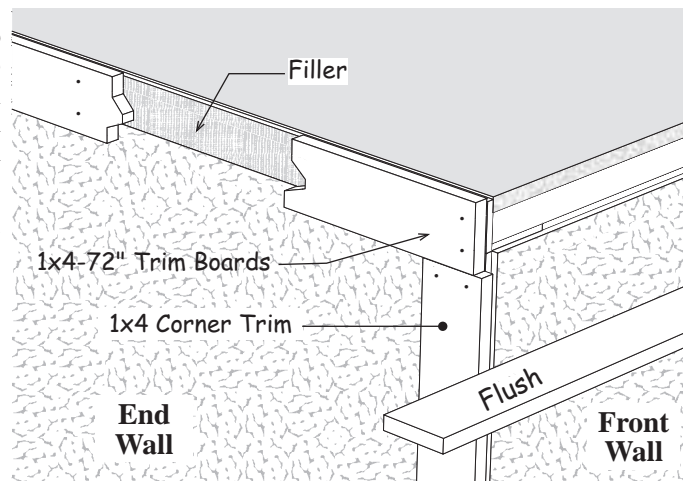

Step 20 Assemble (2) Two 12' Dormer Walls

 Since the dormer walls will be installed on the upper loft, it may be easier to build them on the loft floor. When built, slide the walls over the open area of the loft.

1. Cut (2) two 2x4-12' to 140-1/2". Indicate with 'X' marks, where the wall studs will be located.

140-1/2"	X	X	Window	X	X	X	Window	X	X	
Wall Plates	X	X		X	X	X		X	X	
	← 18-1/2" →		← 27" →		← 24" →		← 24" →		← 27" →	

2. Install (7) seven pre-cut 43-1/2" wall studs from the kit between the top & bottom plates. Nail a 25-1/2" long 2x4 under the top 2x4 wall plate where the windows will be installed. Use 10d coated sinker nails.
3. Install 3-1/2" x 27-3/4" OSB filler boards on the sides of the window openings. Use (6) six 6d common nails per filler strip.
4. Install pre-cut 25-1/2" long 2x4s under the OSB fillers. Toenail using 10d coated sinkers.
5. Cut a 2x4-12' to 140-1/2" and install as a tie plate across the top of the wall frame using 10d coated sinkers spaced 16".

window opening detail

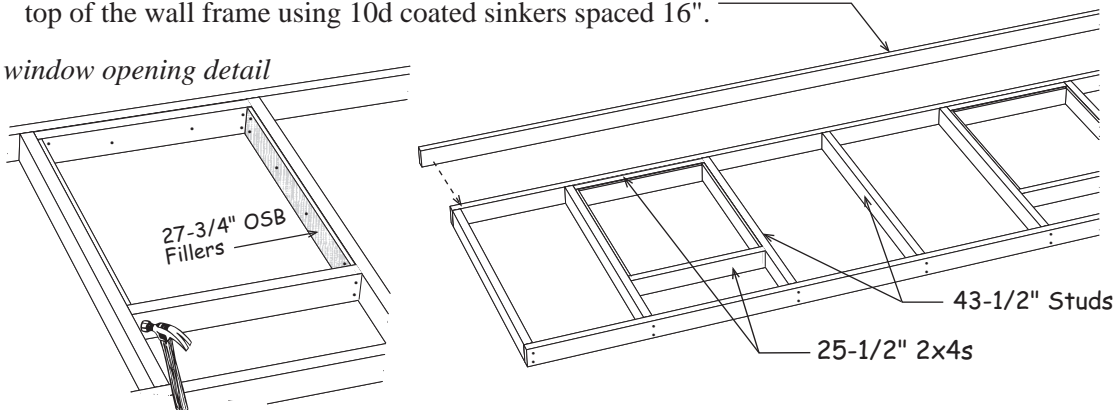

6. Locate the OSB panel that was used to cover a pallet and cut to a length of 48". Locate the other 48" OSB panel shipped in the kit for use in this step as well.
7. Square the wall frame. Install (2) two 46-1/4" x 48" high OSB panels (with window cut-outs) on the ends of the wall frame and (1) one 48" x 48" solid panel in the middle. Use 7d coated sinker nails spaced 10" apart.
8. Draw a line in the center of the wall panel for reference.
9. Repeat steps to assemble another dormer wall panel.

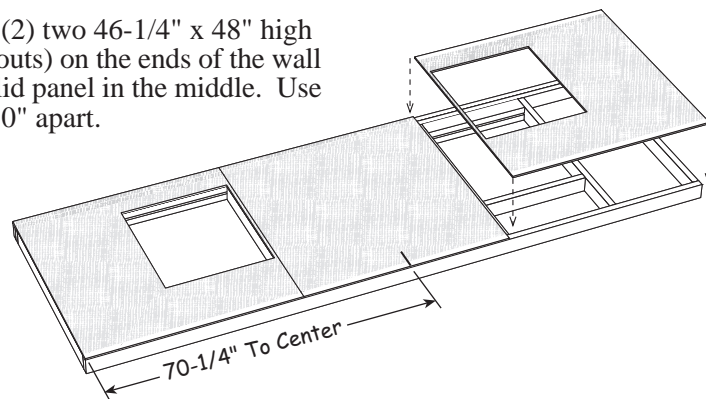

Step 18 Assemble Roof Gables End Frames

1. The gable frames are shipped nested together. Remove hardware and other material placed inside the frames. Separate these frames by removing screws. The screw bit is packaged in the hardware bag.

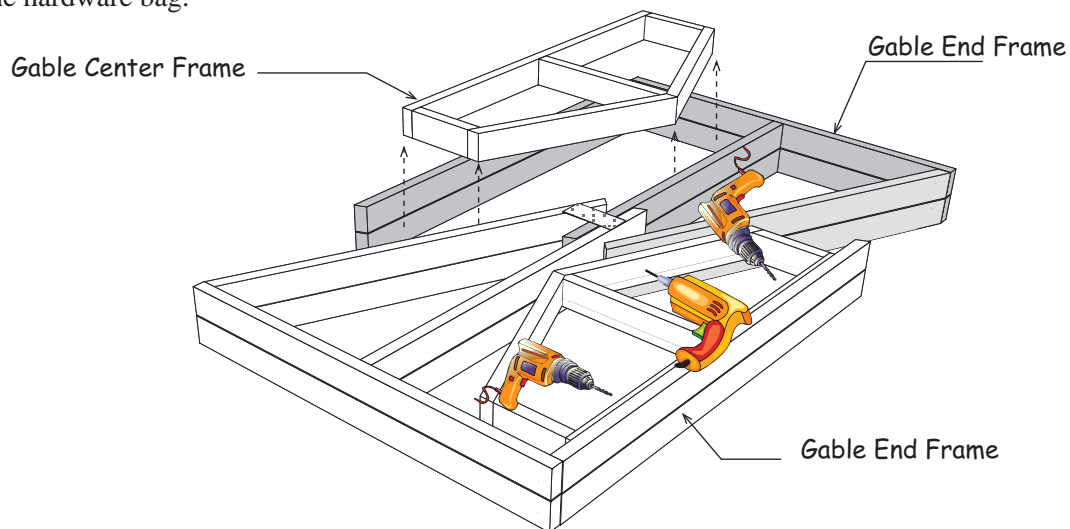

2. After the frames are separated select one of the end frames and install a 31-3/4" long 2x4 (angle cut both ends) across the top. Secure the 2x4 with 2-1/2" wood screws. The siding, installed next, will securely hold all the 2x4s in place.

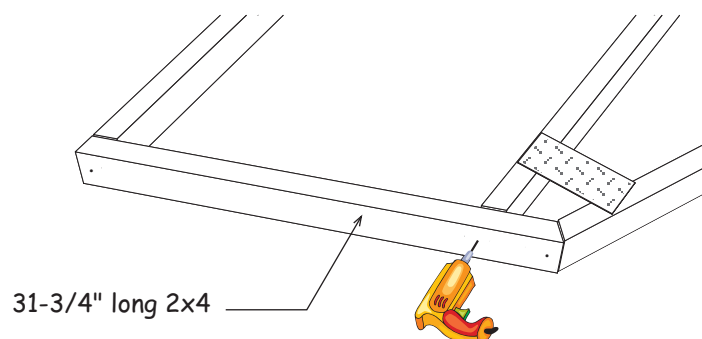
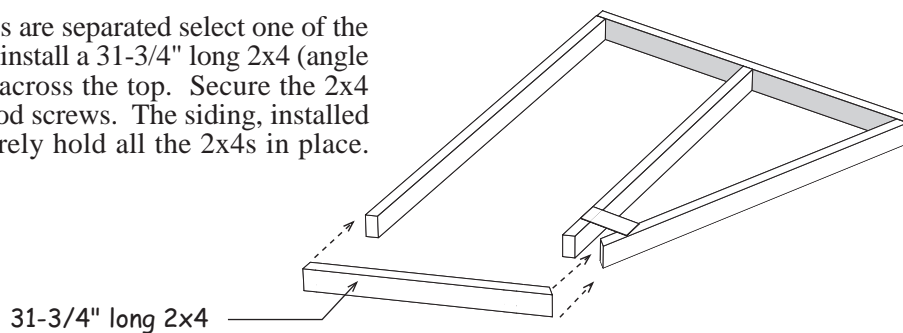

3. Repeat process to disassemble and install the top 2x4 on all (4) four gable frames.

Step 19 Assemble Roof Gables

👉 Building Tip: To aid in the assembly of the gables, temporarily tack 1x4 blocks to the floor. This will trap the gable frames and ensure the other gable and roof trusses, *assembled next*, will be assembled the same.

1. Place a left and right and center gable frame on the floor and hold the frame in position using 1x4 blocks; tack-nail blocks to floor. Secure frames together using 2-1/2" screws.
2. Screw (2) two 47-1/2" long 2x4s to the sides of the left and right end wall frames using 2-1/2" wood screws.

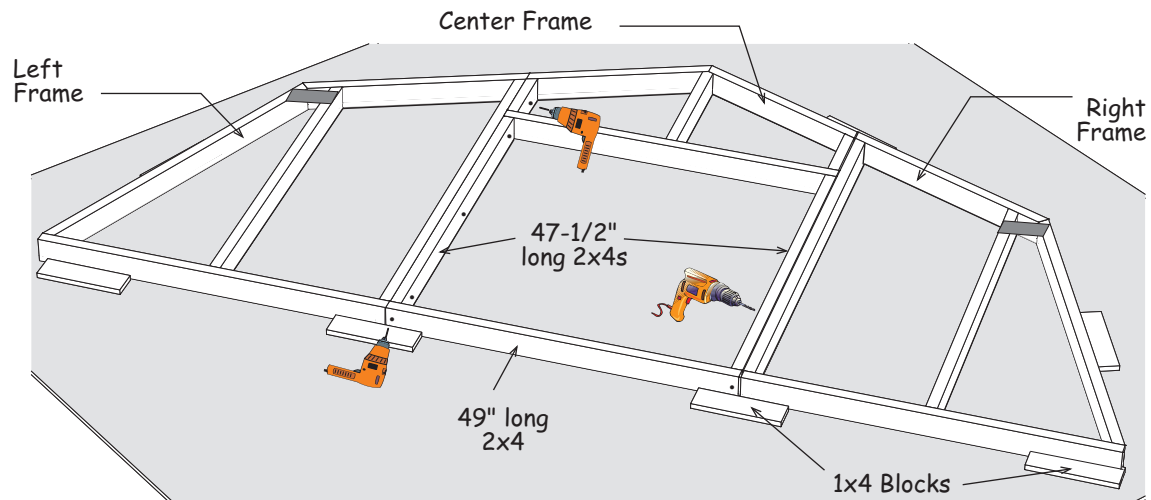

3. Screw (1) one 49" long 2x4 to the bottom of the 2x4s installed above using 2-1/2" screws.

4. Install (2) two 47-1/2" wall studs where shown in detail on right using 10d coated sinker nails.

5. Cut the 2x4s listed below from (2) two 2x4-6' boards.

1 pc. 24-1/4"

2 pcs. 18-1/2"

6. Install these 2x4s in the center of the gable.

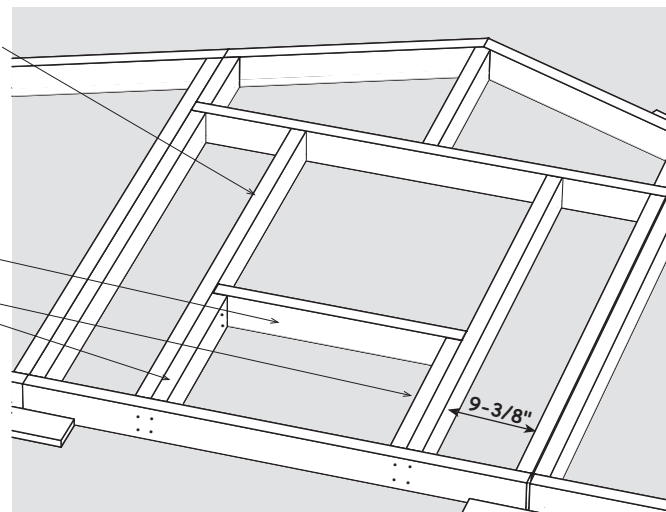

Step 20 Apply Siding to Roof Gables

1. Install a siding panel on the left end of the gable frame with the 'Cut Edge' flush with the side of the frame. The siding should extend $\frac{3}{4}$ " below the bottom plate. Use 8d galvanized box nails spaced 8" apart. Install the center panel and the right end siding panel.
2. Remove this gable panel, placing it on top of the dormer walls to allow room to assemble another set of gable frames. Repeat **Steps 22 & 23** to assemble and apply siding to a second set of gable frames.

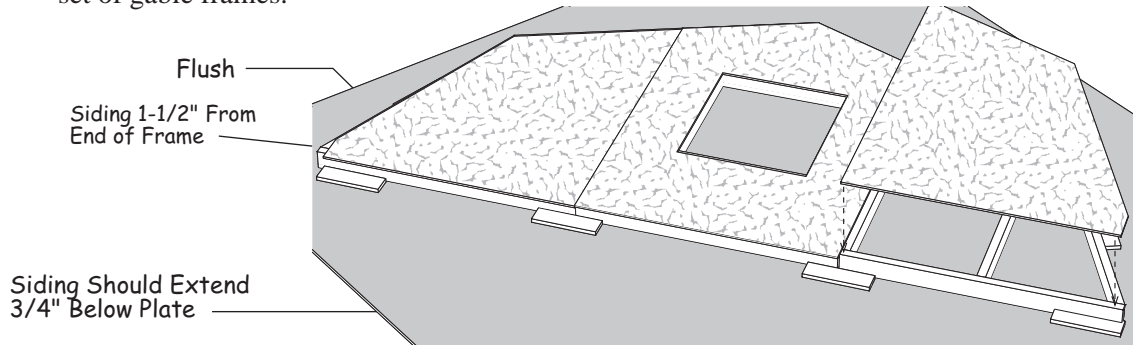

Step 21 Assemble Roof Trusses

1. Place (2) two 58- $\frac{1}{2}$ " long 2x6s and (2) two 50" long 2x6s against the 1x4 blocks. This will ensure the trusses will be aligned with the roof gables. You will need to reposition the 1x4 blocks to meet the bottom of the rafter leg.
2. Secure the top 2x6 rafters in place with a 47- $\frac{1}{4}$ " long 2x4 and a 15- $\frac{3}{4}$ "x48" wood gusset. Apply wood glue between the boards. Secure gussets with (2) two rows of 6d common nails spaced 6" apart.
3. Secure the knee of the truss with a 24" long 2x4 and a 10- $\frac{1}{2}$ "x24" wood gussets. Use wood glue and secure gussets with (2) two rows of 6d common nails spaced 6" apart.

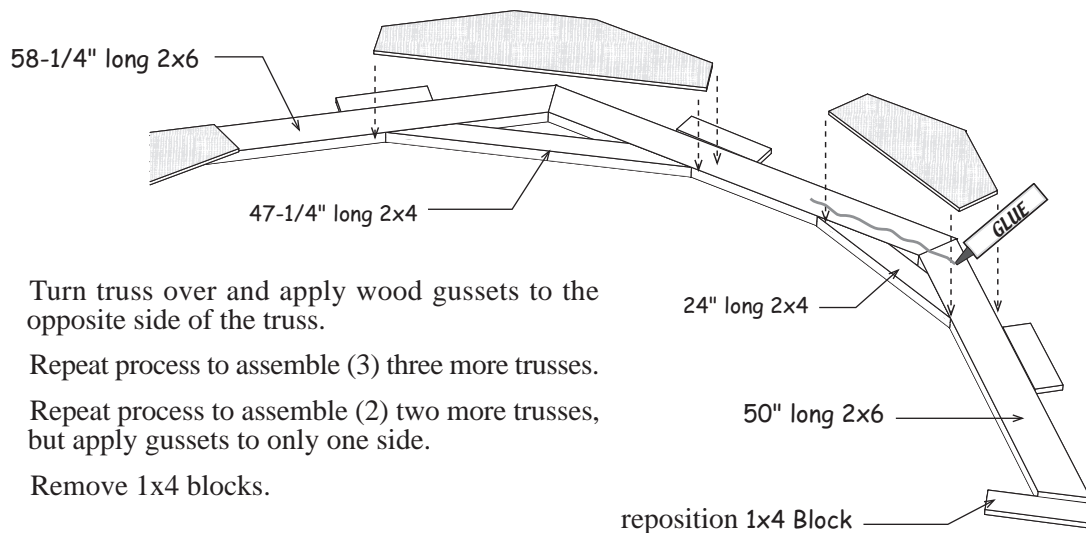

4. Turn truss over and apply wood gussets to the opposite side of the truss.
5. Repeat process to assemble (3) three more trusses.
6. Repeat process to assemble (2) two more trusses, but apply gussets to only one side.
7. Remove 1x4 blocks.

Step 22 Set Roof Gable and Dormer Wall

1. Install a roof gable over the end wall that has the large floor area. Set the gable with the siding extending over the trim on the lower wall, see **Detail 'A'**. Center the gable; the gable should extend 1-1/2" beyond the flooring on both sides of the building. Install a 2x4 wall brace to secure gable and nail through the bottom plate with 10d coated sinkers; use 3 nails per stud opening.
2. Set the dormer wall on the floor with the center mark on the dormer wall lined with the mark on the center of the loft floor. The dormer wall should be 2-1/2" from the edge of the loft floor; see **Detail 'B'**.
3. Nail the dormer wall to the floor using 10d sinkers, close to the back of the OSB so the nails go into the 2x6 joist header. Nail through the bottom plate into the 2x6 floor joist. Use 3 nails per stud opening.

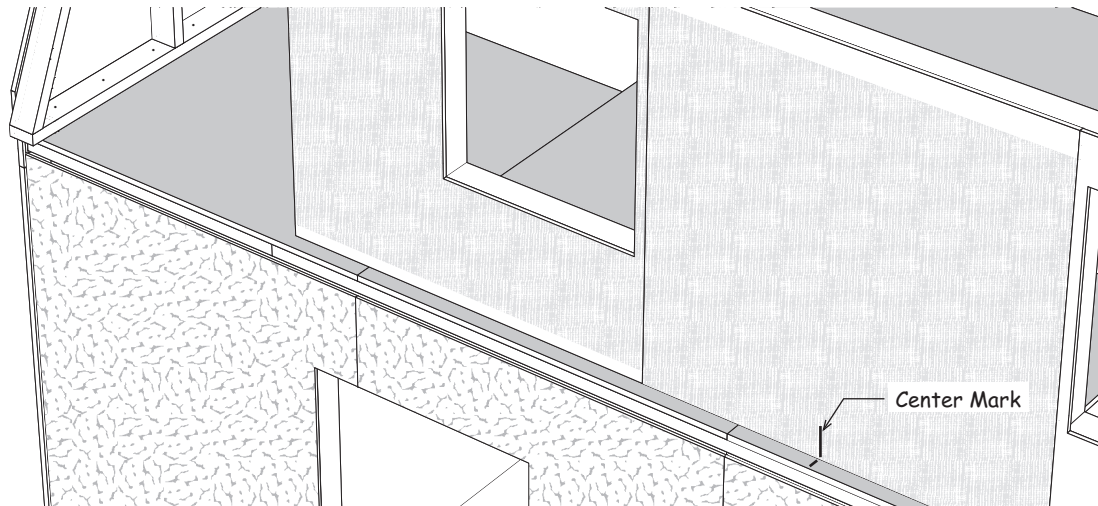

DETAIL 'A'

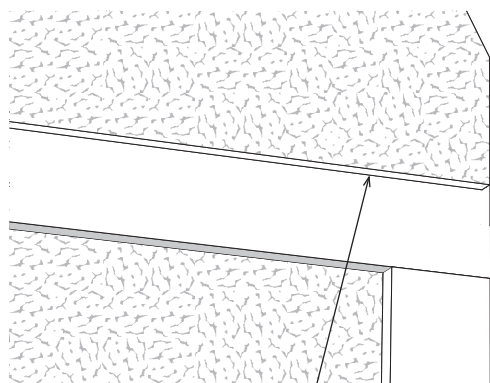

Gable Extends
1-1/2" Past Wall

Nail & Paint Bottom
Edge of Siding.

DETAIL 'B'

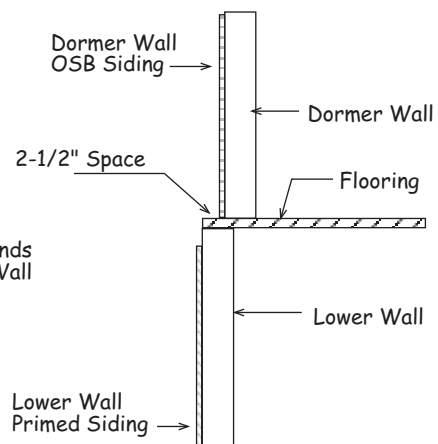

Dormer Wall
OSB Siding

Dormer Wall

2-1/2" Space

Flooring

Lower Wall

Lower Wall
Primed Siding

4. Repeat this step to set the second gable and dormer walls.

Step 23 Install 2x6 Truss Plates

1. Cut truss plates to length from 72" long 2x6 boards, the truss plates will be approximately 71-3/8" in length. Install one at each corner against the gable. Install the 2x6 plate 1/2" from the end of the gable plate. Nail each plate using 10d sinker nails.

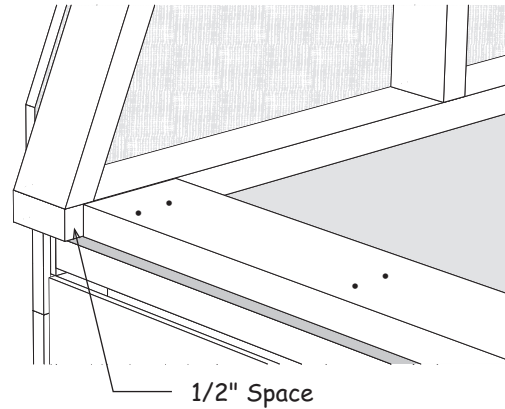

Step 24 Install Dormer Truss

1. Working on the loft floor, set the dormer truss assembled in **Step 1** on the end of the dormer wall with the side that has the notch cut into the OSB sheathing facing towards the center of the building. Nail a 2x4 block to the top of each side of the dormer wall to help support the dormer truss; see **Step 31**. Screw the truss to the 2x4 blocks with 2-1/2" wood screws to hold the truss upright.
2. Install pre-cut OSB sheathing flush with the top of the truss as shown below. Nail sheathing to dormer truss with two rows of 6d common nails. Install small filler shown below.

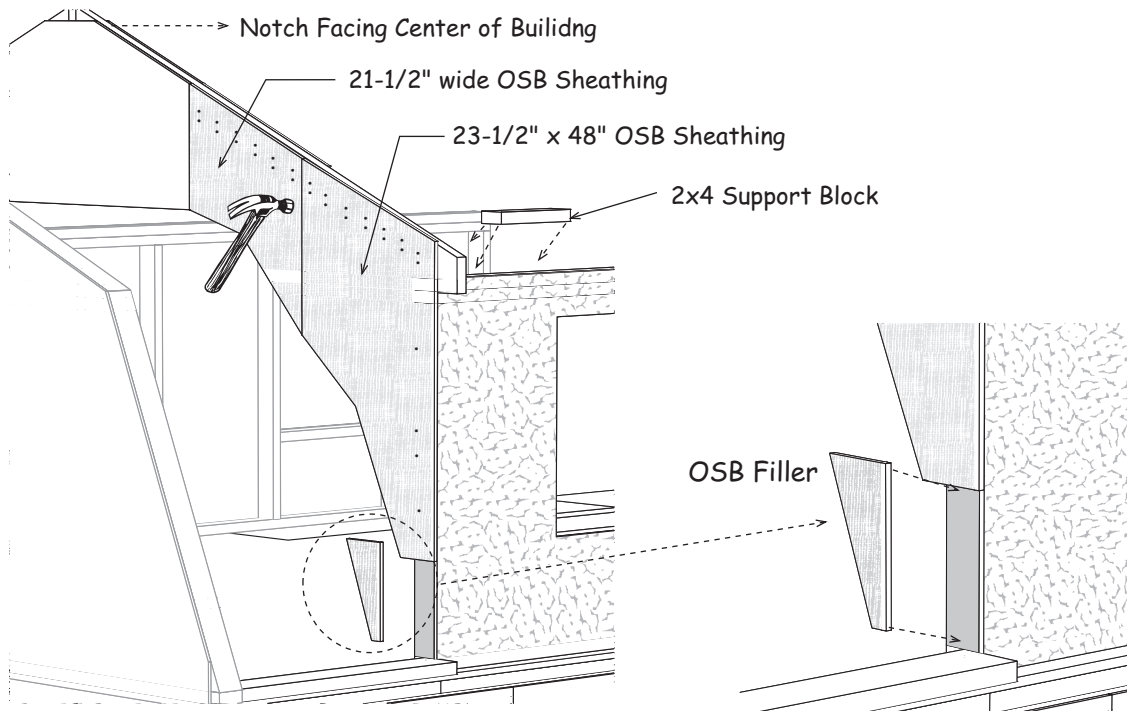

Step 25 Install Gambrel Truss

1. Select the truss that has a gusset applied to one side. Install this truss against the dormer wall with the gusset facing the roof gable. The bottom tip of the truss will extend past the truss plate. The truss should align with the gable end; refer to **Step 26**.

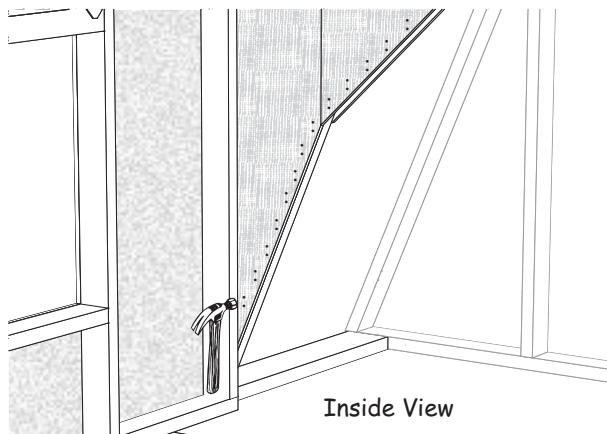
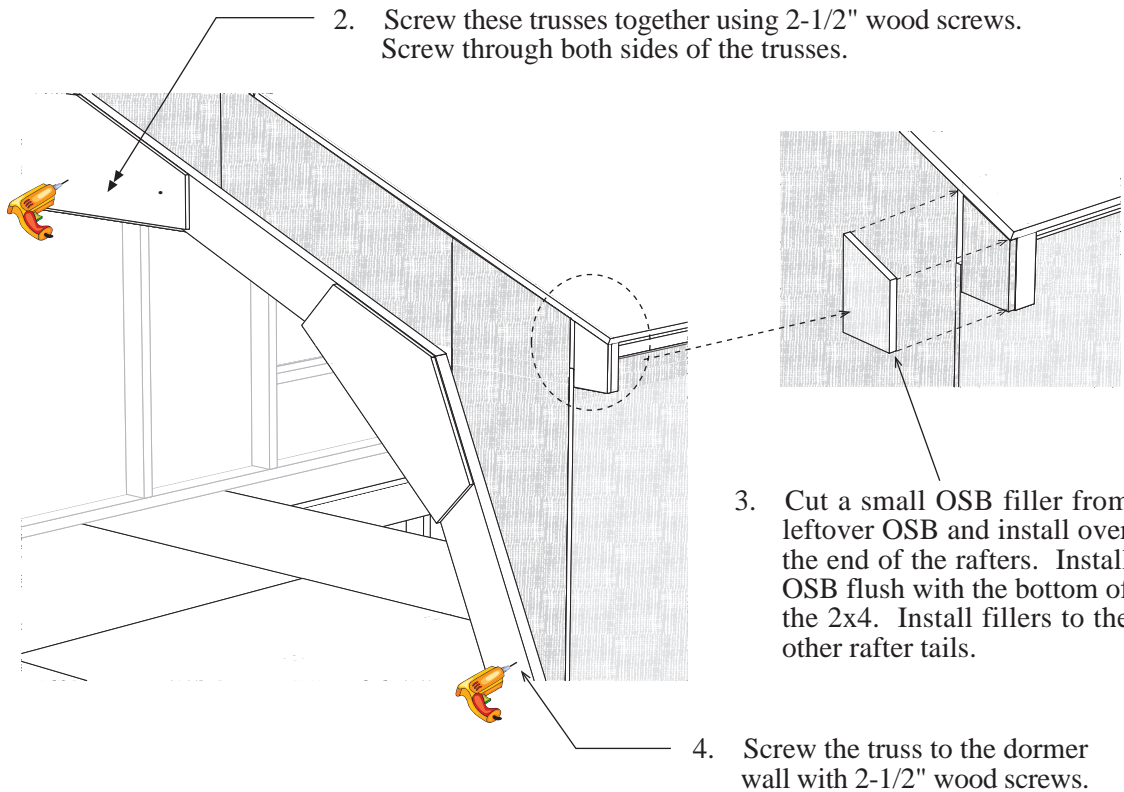

Step 26 Install Common Trusses

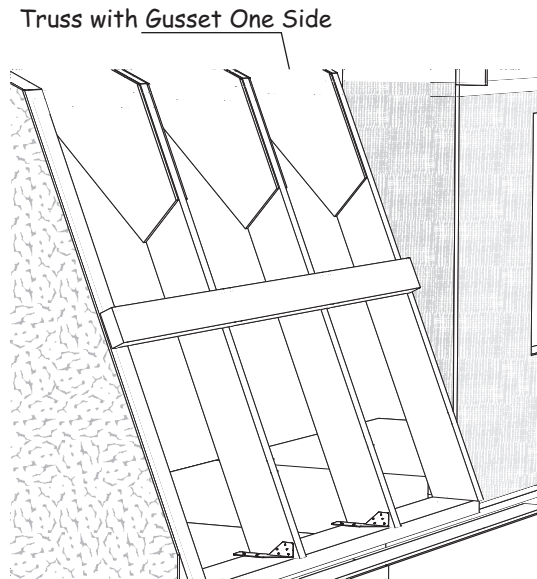

1. Select the trusses that have gussets applied to both sides. Install these trusses between the gable end and the truss just installed. Space the trusses as show below.
2. Secure these trusses using left and right metal brackets. Use 6d common nails to secure a bracket to the truss plate, and two 1-1/4" screws to secure the truss. Bend down the bracket where it extends past the 2x6 plate. Install another set bracket on the other side of the truss.
3. Install another truss in the center of the opening between the first truss and dormer wall.

Center This Truss

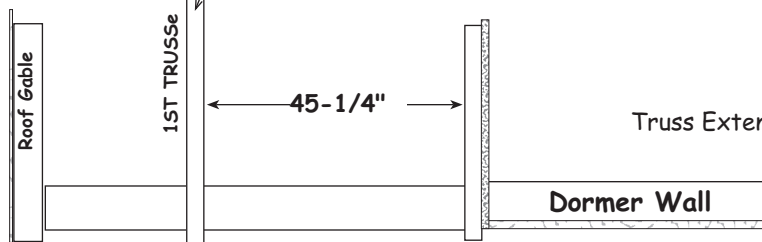
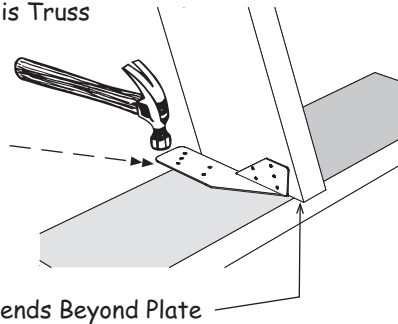

Step 27 Install Dormer Trusses

Use scaffolding and a helper to install the dormer truss, gambrel truss and common trusses. Repeat **Steps 24 - 26**.

Use caution while on the scaffolding.

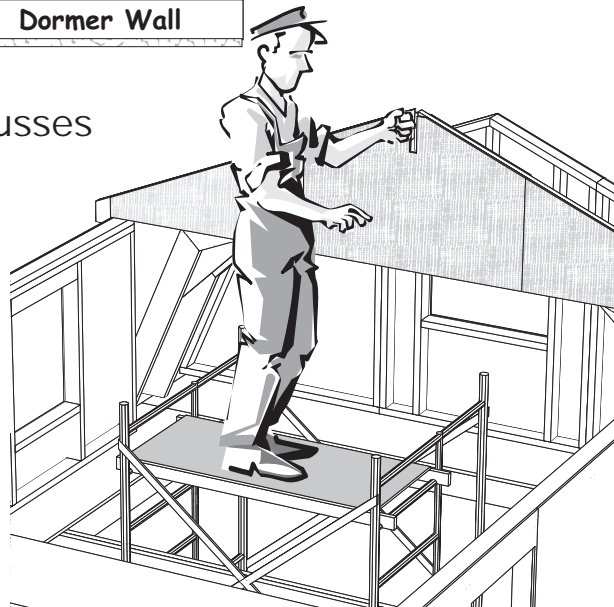

Step 28 Install 2x8 Ridge Beam

1. Cut a 2x8 board to a length of 140-1/2" and install as a ridge beam into the slots of the dormer trusses.
2. Secure the ends of the 2x8 with a metal joist hanger and 10d coated sinker nails.
3. Layout where the 2x6 rafters will be installed on the ridge beam; *see below*.

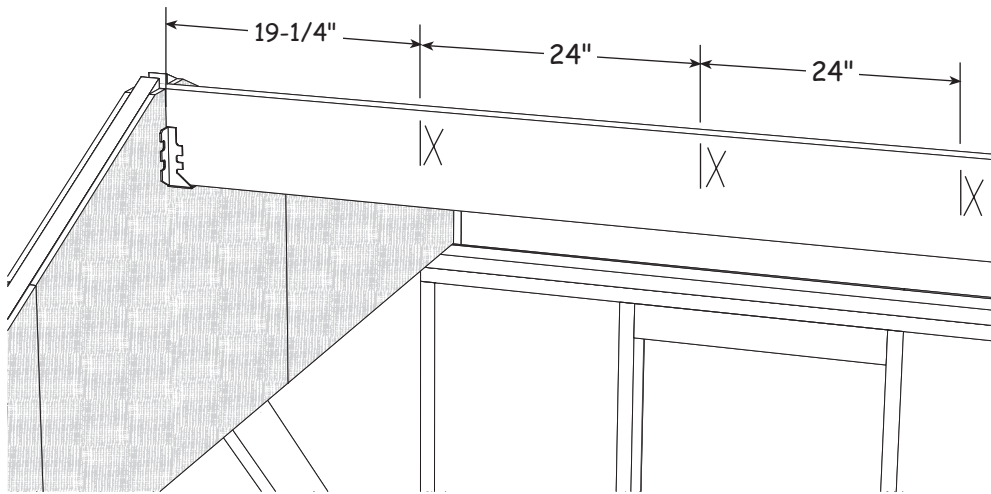

4. On both dormer walls, layout where the 2x6 rafters will be installed; *see below*. Install H1 hangers where the rafters will be placed over the 'X' marks. Use 6d common nails to nail the hangers to the truss plate. When the rafter is set (next step), use a 1-1/4" screw on each side of the hanger, and toenail the rafter to the truss plate using 10d coated sinker nails.

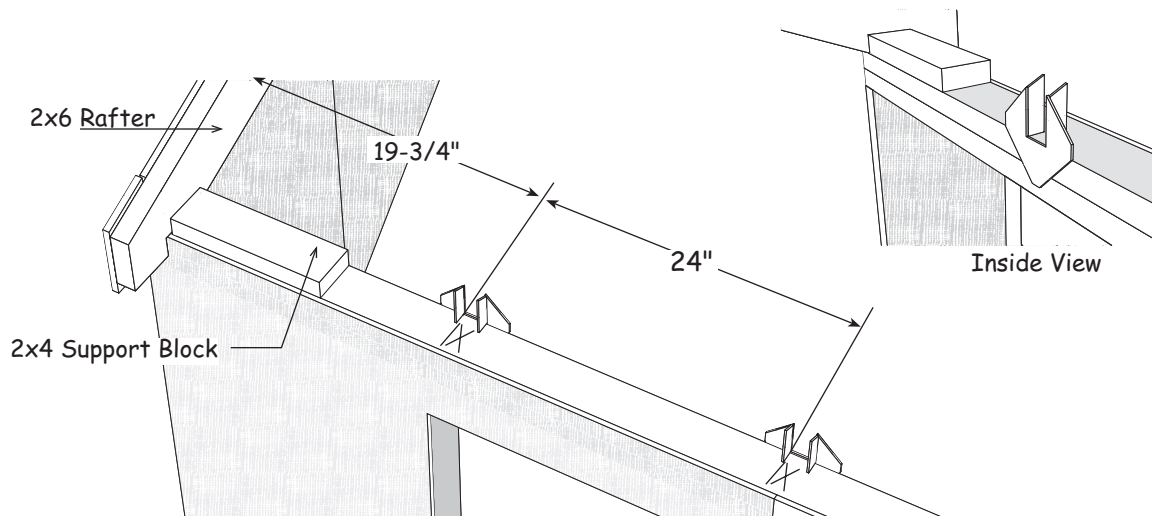

Step 29 Install 2x6 Rafters

Locate (10) ten 78-3/4" long 2x6 rafters. Working from the center, install (2) two rafters on the front side of the ridge and one back side. The rafters should align with the dormer trusses and will be approximately 3/4" above the ridge beam to allow for ventilation. Use a string to check the alignment. Secure the rafters to the ridge beam with H1 hangers using 1-1/4" screws. When possible screw through the ridge board into the rafter using 2-1/2" deck screws. Install the remaining rafters alternating one on the front of the ridge and then one on the back side. This will help keep the ridge board straight.

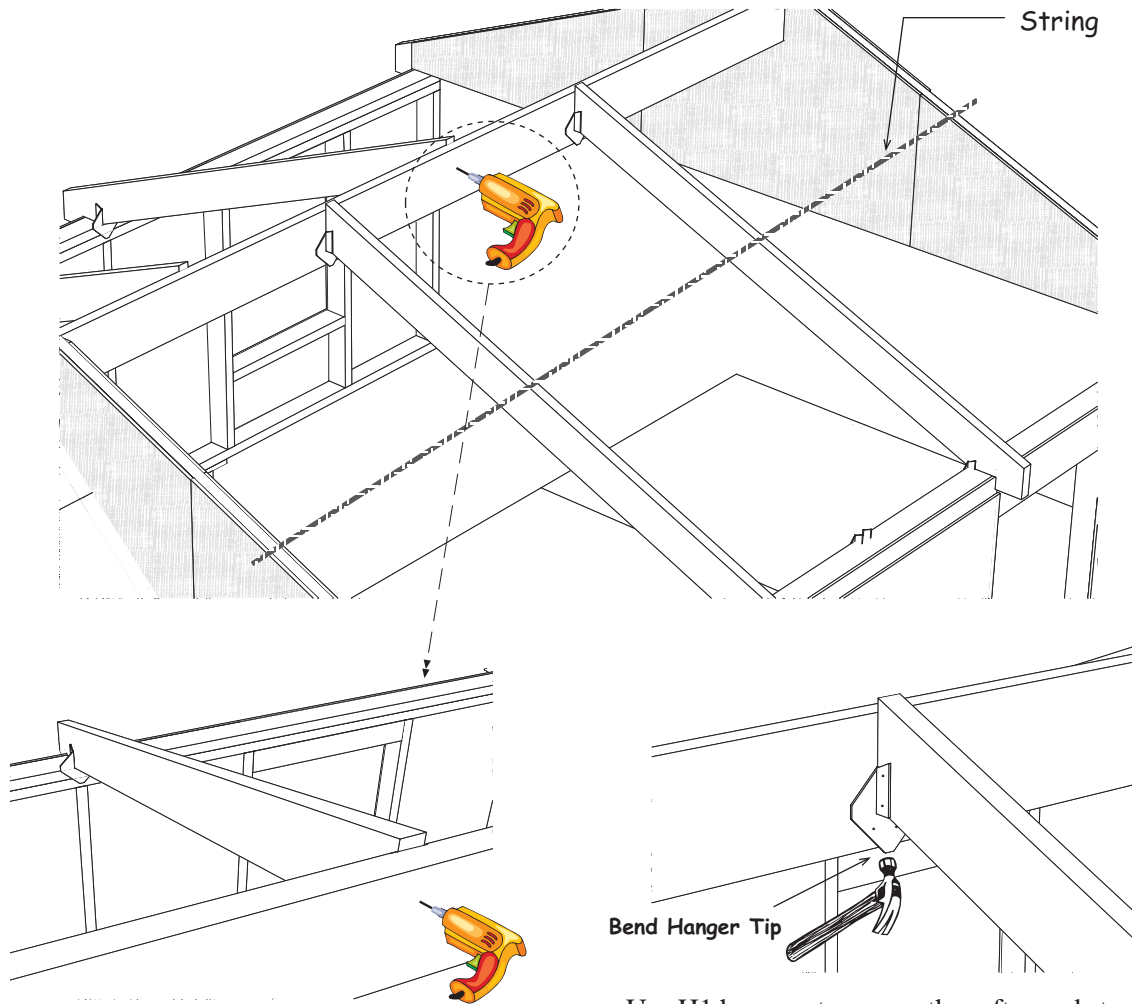

Use H1 hangers to secure the rafter ends to the ridge using 1-1/4" screws. Using a hammer, bend the hanger tips that extends below the ridge.

Step 30 Install Roof Sheathing & Soffit Boxes

1. Install 5/8" plywood roof sheathing as shown below. Install the roof sheathing starting in the center of the rafters. Insert pliclips between rafters; see **Step 31** for detail. The roof sheathing will extend approximately 1-1/4" past the sheathing on the dormer ends. Use 7d coated sinker nails spaced 6" apart. Extend the sheathing 3/8" below the end of the rafter. **Tip:** Use a piece of primed siding as a gauge. The top row of roof sheathing will be about 1-1/2" below the ridge to allow for ventilation.
2. Repeat on back of building to install roof sheathing.

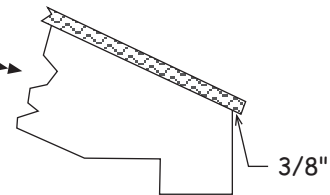
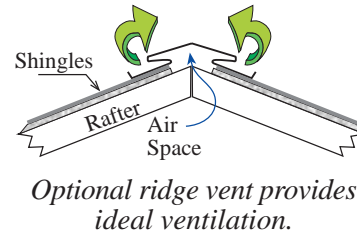
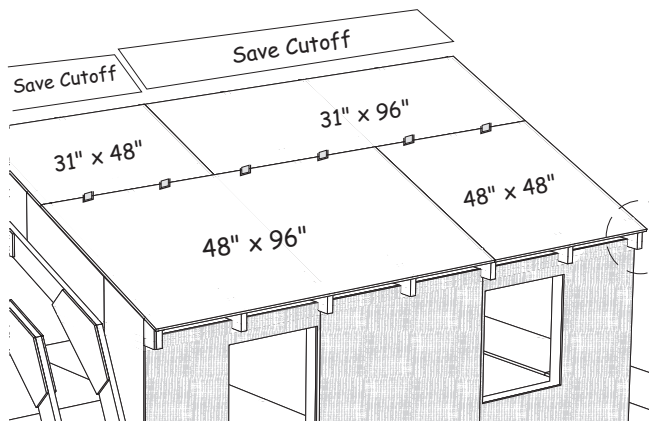

3. Use a soffit gauge block and a straight edge to set the location of the soffit box. Use the straight edge to align the top of the 2x4 block flush with the top of the 2x6 rafter. Draw a line across the siding to set the pre-built soffit boxes.
4. Install a 73" long pre-built soffit box on the front wall, flush with the siding on the roof gable (3/8" beyond the end wall corner trim). Screw the soffit box to the wall with 2-1/2" long screws anchoring into the wall studs behind.

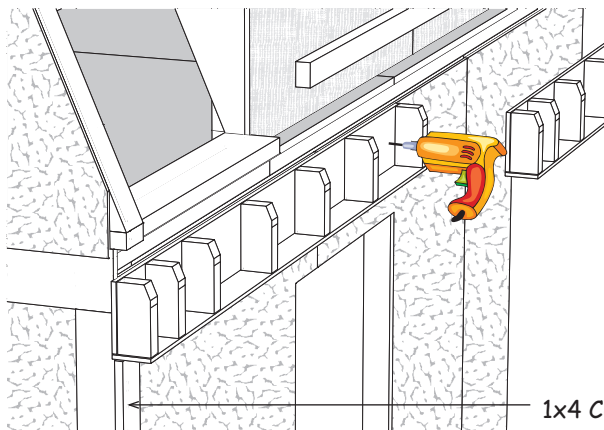
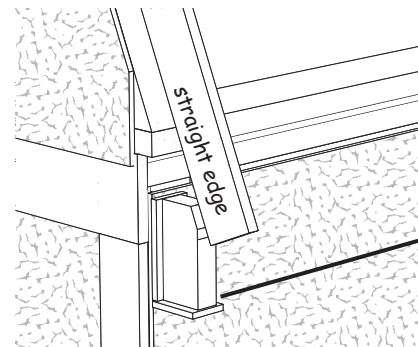

5. Install (2) two more 73" long soffit boxes and (1) one 72" soffit box. Screw soffit boxes together with a 2-1/2" screw.
6. Cut a 96" long 1x4 trim boards to length and install as corner trim on the lower wall using 8d galvanized box nails.
7. Repeat steps to install soffit boxes and trim on the back wall.

1x4 Corner Trim

Step 31 Install Roof Sheathing - Lower Roof

1. Screw (2) two 2x3-6' long boards (cut boards to fit) to the dormer wall to support the roof sheathing installed later. Use 2-1/2" wood screws spaced to catch the wall studs behind. Align the top corner of the 2x3 board with the top of the 2x6 truss.
2. Repeat to install 2x3s on the back dormer.

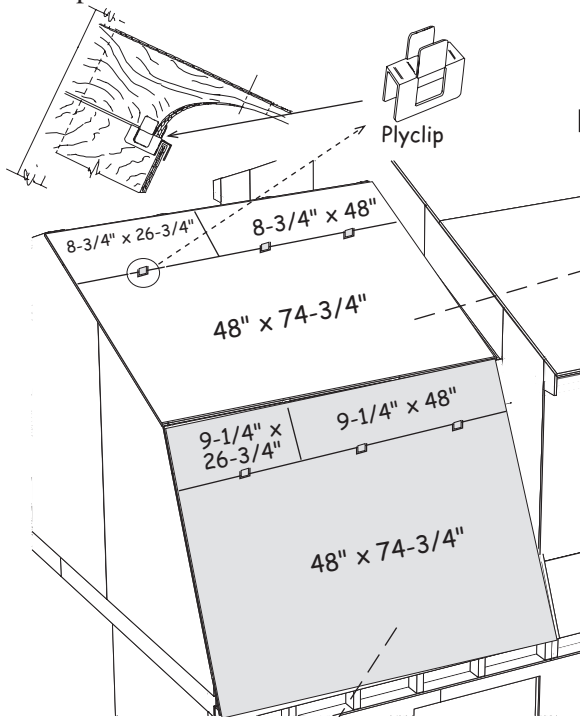
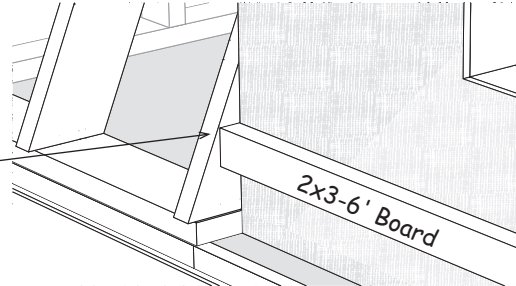

IMPORTANT: Use scaffolding and a helper to install this roof sheathing.

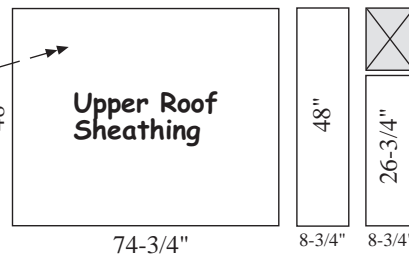

2. Cut a 5/8" plywood panel into the sizes shown above. Install the 8-3/4" panels 1" from the peak of the gambrel trusses. Install the 48" panel next, inserting plyclips between the smaller and large sheathing panels. Use 7d sinker nails spaced 6" apart.
3. Cut another plywood sheathing panel for the lower area.
4. Repeat procedure to install sheathing on the other corners.

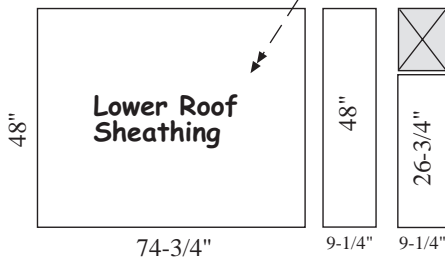

5. Use sheathing cutoffs from **Step 29** to fit and install under the front and back dormer walls. Nail the top of the sheathing into the 2x3 nailer using 7d coated sinker nails spaced 8" apart. Nail into each soffit block as well.

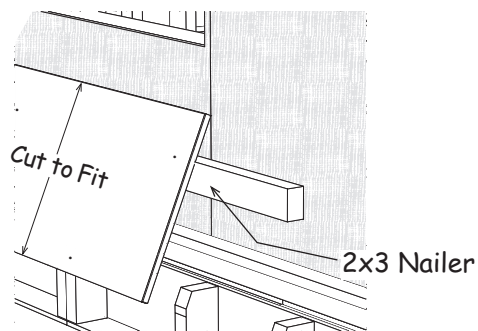

Step 32 Install 1x6 Fascia Boards on Lower Soffit

1. Install a 73" long 1x6 fascia board over the front soffit box. Install 1x6 against the bottom of the roof sheathing, flush with the siding on the roof gables. Use 8d galvanized box nails spaced to catch the 2x4 blocks behind.
2. Install (2) two more 1x6-73" fascia boards.
3. Repeat to install fascia on the back soffit boxes.

1x6 - 73" Fascia

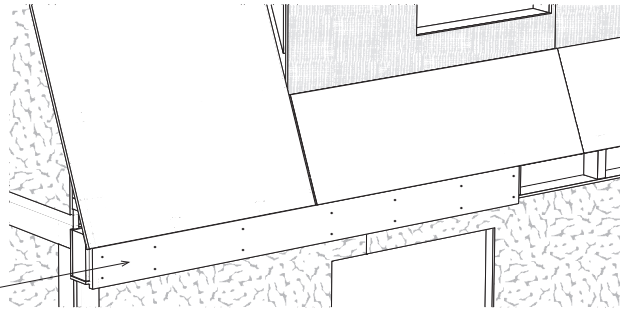

Install Roof Covering and Dormer Flashing - Owner Supplied



If you purchased our optional pre-cut metal roof package, follow the instructions included with that kit for the rest of the construction process. If you purchased a different metal roof system, follow the manufacture's installation instructions and special assembly instructions as noted in the following steps.

IMPORTANT: Flashing must be installed before applying the dormer siding. Apply flashing *prior to* installing shingles, or *after* metal roof panels are installed.

1. Install roof paper over the roof sheathing. Fold the roof covering so it also cover the sheathing on the dormer front and sides.
2. Install (2) two 78" long pieces of metal flashing over the dormer. Extend the flashing 2" beyond the front sheathing. Cut the flashing to extend around the dormer. Tack in place across the top using 6d common nails.
3. Install flashing on the back dormer.

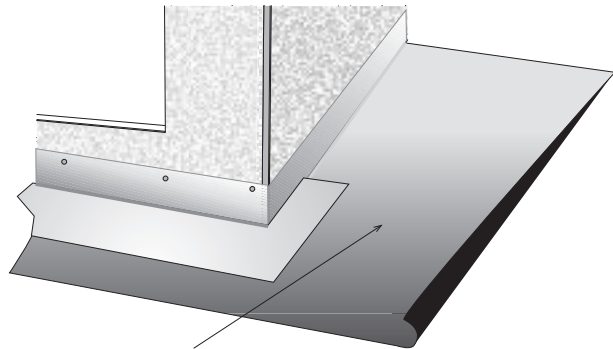

Roof Paper or Ice Guard

Step 33 Install Dormer Siding

1. Cut (2) two 72" long 1x4 boards across the bottom of the dormer rafters (see **Step 35** for larger detail). Use 8d galvanized box nails.
2. Install (3) three 33-3/4" high siding panels on the front and back dormer walls using 8d galvanized box nails spaced 8" apart. **Important:** Paint the bottom edge of the siding.

NOTE: If you are installing a meal roof, trim 1" off the bottom edge of the siding panels to allow more space between the top of the roof panels and bottom of the siding.

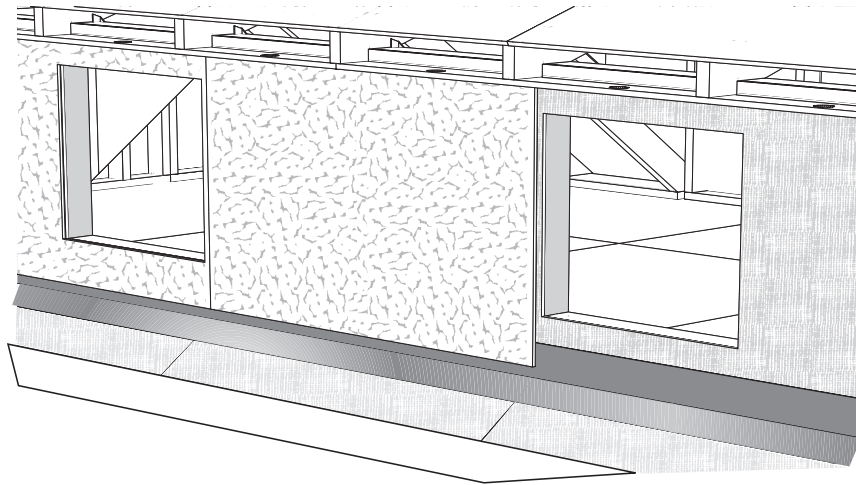

Install Finish Roof Covering - Owner Supplied

Install shingles according to the instructions on the wrapper. This roof design is more complex than a straight roof and requires flashing to be installed. You may want to consider hiring a professional roofer who has the necessary equipment to install the finish roof covering.

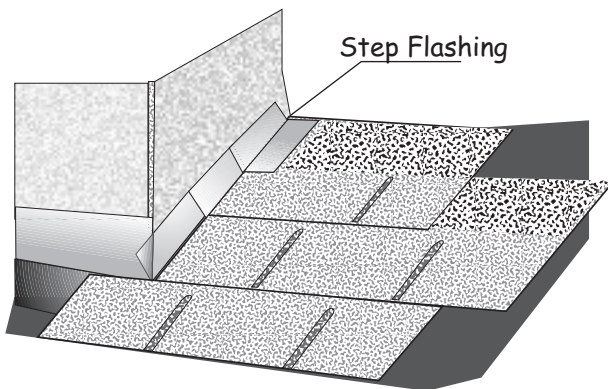

1. Install metal roof edging on the perimeter of the roof area. If you are not installing shingles at this time, you can purchase felt paper to protect the roof sheathing. Install the felt paper before you install the metal roof edge.
2. Interlace step flashing along the side of the dormer walls as you install shingles.

Building Tip: *Install ridge vent in lieu of shingles caps. Ridge vent provides ideal ventilation, preventing heat and moisture build-up from damaging your building or its contents.*

Step 34 Install Primed Siding on Dormer Sidewall

 *If you are installing a metal roof, trim 1" from the bottom edge of these siding panels to allow more clearance for the roof panels.*

1. Install a 27"x38" long primed siding panel under the roof sheathing on the side of the dormer. Install the siding flush with the siding on the front of the dormer. Use 8d galvanized box nails.
2. Install a 9" wide x 48-3/4" long primed siding panel on the dormer side using 8d galvanized box nails.
3. Install the same siding pieces on the back side of the building and on the opposite end of the dormer.

Important: Paint the edges of these siding pieces before installing.

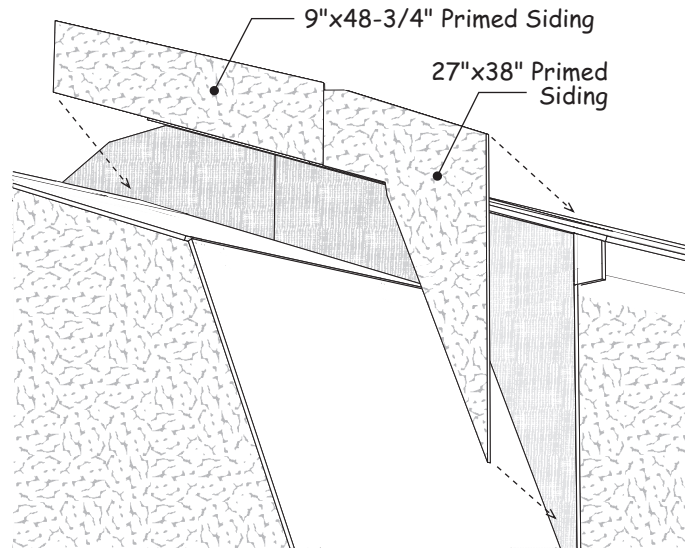

Step 35 Install Dormer Soffit & Corner Trim

1. Install 33-3/4" long 1x3 corner trim flush with the siding on the dormer sides. Use 8d galvanized box nails.
2. Repeat to install 1x3 trim on the other corners.

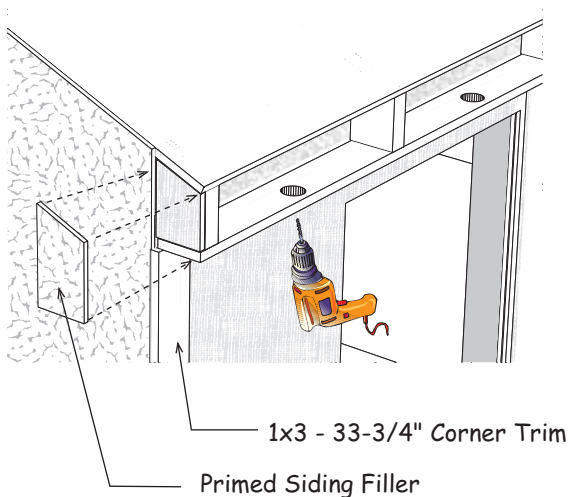

3. Cut small fillers from leftover siding to cover the end of the rafters and the 1x4 soffit boards. Install with 8d galvanized box nails. The gable trim applied later will cover most of the filler.

 *If you intend to insulate the roof, drill 2" holes between the dormer trusses and install the round soffit vents provided in the kit. You also need to drill (2) two 2" holes in the soffit area located below the gambrel trusses and install round soffit vents. Drill (2) two holes at each corner of the building. A hole saw drill bit can be purchased at any hardware store.*

Step 36 Install Upper 2x4 Gable Overhang

1. Install a 79-1/2" long 2x4 on the side of the dormer under the roof sheathing. Use 10d coated sinker nails.

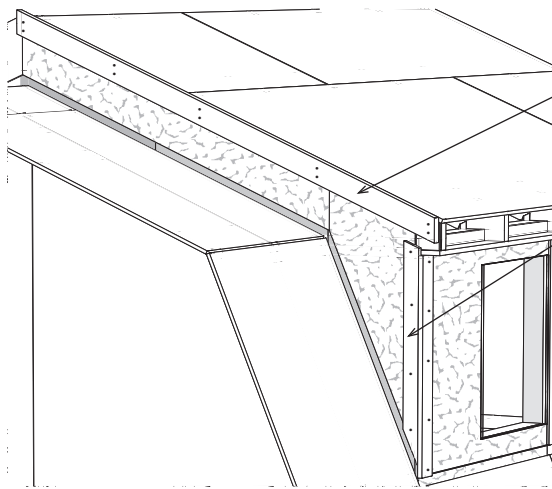

2x4 Gable Overhang

4. Install 36-1/2" long 1x3 corner trim on the side of the dormer using 8d galvanized box nails.
5. Repeat steps to install 2x4 and corner trim on the other corners.

Step 37 Install Upper Gable Trim & Fascia Trim

1. Install an 80-1/2" long 1x6 dormer rafter trim flush with the top of the roof sheathing and end of the rafters using 8d galvanized box nails spaced 16" apart. Trim to fit, if needed.

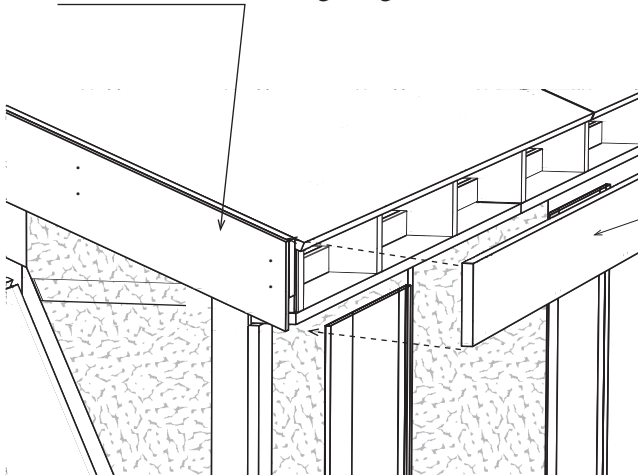

2. Install (2) two 73" long fascia boards across the rafters using 8d galvanized box nails. Trim to fit as needed.
3. Repeat to install gable trim and fascia on the opposite corner and the back of the building.

Step 38 Install Lower Gable Trim

1. Install (2) two 59" long 1x6 gable trim boards at the top of the roof gables, flush with the roof sheathing, using 8d galvanized box nails.

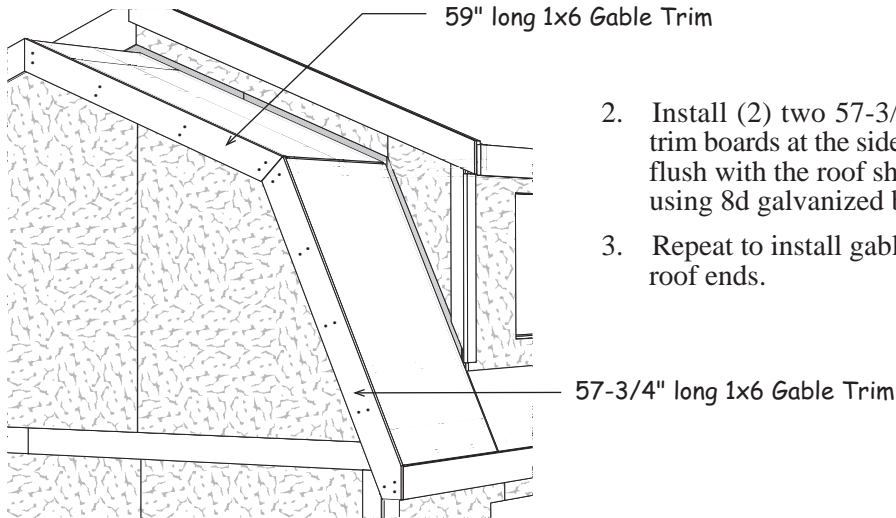

2. Install (2) two 57-3/4" long 1x6 gable trim boards at the side of the roof gables, flush with the roof sheathing and fascia, using 8d galvanized box nails.
3. Repeat to install gable trim on the other roof ends.

Step 39 Install Windows

General Instructions for Installing Upper Windows

1. Apply window caulking around the window opening before installing the windows.
2. Insert window in opening. Have someone hold window in place from the inside or the outside.
3. **DO NOT** use a hammer to nail through the flange.
4. Insert a 1x3 trim board along each side of the window, flush with the top and bottom window frame. Secure trim boards using (4) four trim screws.
5. Install the bottom and top trim boards.
6. Apply caulking along the top of the 1x3 trim board.



See instructions from the window manufacture for applying trim around lower window.

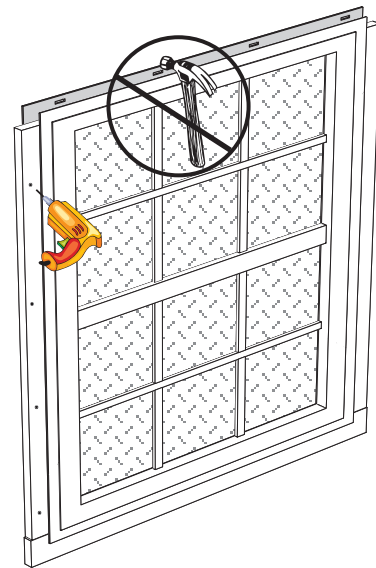

Optional Pre-cut Metal Roof Kit

A pre-cut metal roof kit offers pre-cut metal roof panels and all necessary flashing and trim accessories. This kit will eliminate costly waste as all the roof panels are cut to exact length. The metal flashing around the dormer is pre-cut to fit properly. Metal roof edging, gable trim and ridge cap is also pre-cut and supplied. Necessary screws and insect-guard for the ridge is included along with a detailed instruction manual. Protective covering (felt paper or underlayment) over the roof sheathing should be installed prior to the roof panels. You will need to purchase 630 sq. ft.

For more information and ordering go to www.shedkitstore.com

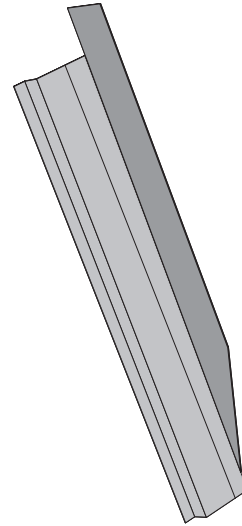
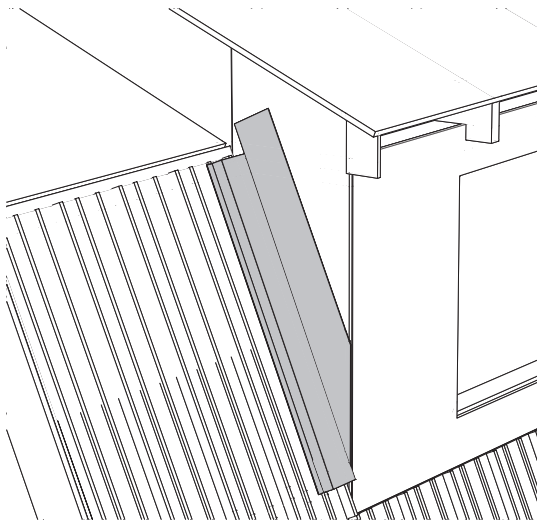

✓	Material Supplied By Local Home Center	
64	Pre-cut Wall Studs	
3	Wall Plates - Treated	2x4 - 8'
4	Wall Plates - Treated	2x4 - 12'
3	Wall Plates	2x4 - 8'
16	Wall & Tie Plates	2x4 - 12'
1	Ridge Beam	2x8 - 12'
4	Floor Joist / Door Header	2x6 - 8'
18	Floor Joist for Loft	2x6 - 12'
18	LP Exterior Siding	3/8" - 4' x 8'
21	Plywood Sheathing	5/8" - 4' x 8'
2	Tubes of Window Caulking	
2	Tubes of Wood Glue	

✓	<i>Cardboard Wrap</i>	✓	<i>49" x 84" Main Pallet</i>	✓	<i>49" x 84" Main Pallet</i>
	2 2x4 95-3/4"		2 lbs. 16d Galvanized Nails		14 2x6 78-3/4"
	8 1x4 96"		5 lbs. 16d Coated Sinkers		4 2x4 79-1/2"
✓	<i>44" x 72" Pallet</i>		8 lbs. 10d Coated Sinkers		2 2x4 49"
	2 2x6 72"		10 lbs. 8d Galvanized Box		4 2x4 31-3/4" angled
	8 2x6 58-1/2"		6 lbs. 7d Coated Sinkers		4 1x6 80-1/2"
	8 2x6 50"		7 lbs. 6d Common Nails		10 1x6 73"
	2 2x4 72"		100 ea. 1-5/8" Trim Screws		4 1x6 59" angled
	8 2x4 47-1/2"		115 ea. 1-1/4" Drywall Screws		4 1x6 57-3/4" angled
	14 2x4 43-1/2"		120 ea. 2-1/2" Deck Screws		8 1x4 72"
	8 2x4 25-1/2"		30 ea. 5/8" Plyclips		4 1x3 33-3/4"
	4 2x3 72"		22 ea. 2x6 Joist Hangers		4 1x3 36-1/2" angled
	12 1x3 29-3/4"		20 ea. 2" Round Soffit Vents		8 27-3/4" OSB Fillers
	12 1x3 27-1/4"		20 ea. H-1 Hangers		1 Soffit Gauge Block
	6 24" x 27" Windows		8 ea. 6-1/2" L/R Hangers		2 2" Screw bits for drill

✓	<i>49" x 84" Main Pallet</i>	
4	Pre-built Gable Frames	49" x 60"
2	Pre-built Gable Frames	49" x 22"
6	Pre-built Soffit Boxes	6" x 73"
2	Pre-built Truss Saddles	6-1/2" x 9"
4	LP Siding for Gables	48" x 60"
2	LP Siding for Gables	48" x 72"
1	OSB Siding for Dormer	48" x 48"
1	OSB Siding for Dormer	48" x 84"
4	OSB Siding for Dormer	46-1/4" x 48"
4	LP Siding for Dormer	46-1/4" x 33-3/4"
2	LP Siding for Dormer	48" x 33-3/4"
2	LP Siding 	9" x 53-3/4"
6	LP Siding Fillers	2-1/2" x 48"
1	5/8" Plywood Flooring	24" x 48"
1	OSB Header Filler	3-1/2" x 84"
1	OSB Header Filler	5-1/2" x 84"

Finish Roof Covering by Owner

16	bdl.	Roof Shingles (and nails)
16	pcs.	10' Metal Roof Edge
90	pcs.	5x7 Step Flashing
24	l.f.	Dormer Flashing
2	roll	#15 Felt Paper

Odd-Shaped Components

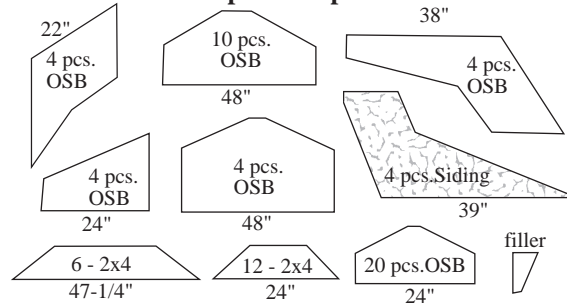

✓	Material in 6' Extension Kit	
2	Pre-built Soffit Boxes	6" x 72"
2	2x6	72"
4	2x6	58-1/2"
4	2x6	50"
2	1x6	72"
1	lb. 16d Coated Sinker nails	
2	lbs. 10d Coated Sinker nails	
2	lbs. 8d Galvanized Box nails	
1	lb. 7d Coated Sinker nails	
3	lbs. 6d Common nails	
8	6-1/2" L/R Hangers	
6	2x6 Joist Hangers	
8	5/8" Plyclips	
4	2" Round Soffit Vents	