

# ASSEMBLY INSTRUCTIONS

## WF195047-DINING TABLE

### IMPORTANT NOTE :





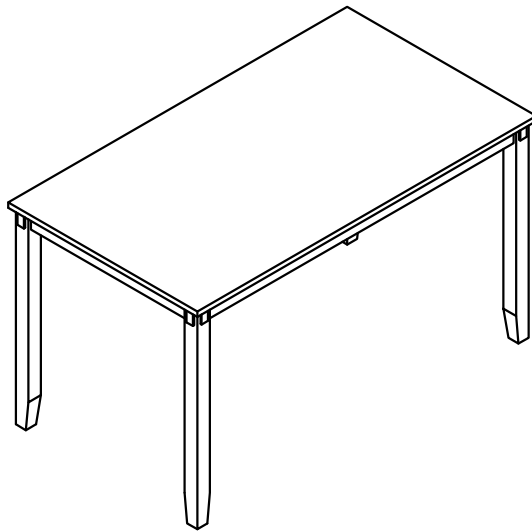

\*\* PLACE ALL PARTS ON A CLEAN AND SMOOTH SURFACE SUCH AS A RUG OR CARPET TO AVOID THE PARTS FROM BEING SCRATCHED.

\*\* BEFORE YOU BEGIN, KINDLY FOLLOW THE ASSEMBLY INSTRUCTIONS STEP BY STEP.

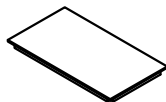
\*\*DO NOT TIGHTEN ALL SCREWS AND BOLTS UNTIL THE TABLE IS FULLY SET-UP.

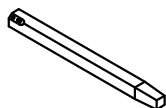

CARTONS ONLY ONE/ CARTONS SEULEMENT UN

PART LISTS				HARDWARE LISTS			
NO.	DESCRIPTION	SKETCH	Q'TY	NO.	DESCRIPTION	SKETCH	Q'TY
1	TABLE TOP		1 PC	A	BOLT Ø5/16" x 60mmL		8 PCS
2	LEGS		4 PCS	B	SPRING WASHER Ø5/16" x 13mmL		8 PCS
				C	FLAT WASHER Ø5/16" x 19mmL		8 PCS
				D	ALLEN KEY		1 PC

MADE IN VIETNAM

1 OF 2

# ASSEMBLY INSTRUCTIONS

## STEP 1:

Remove the corner protectors before assembling legs

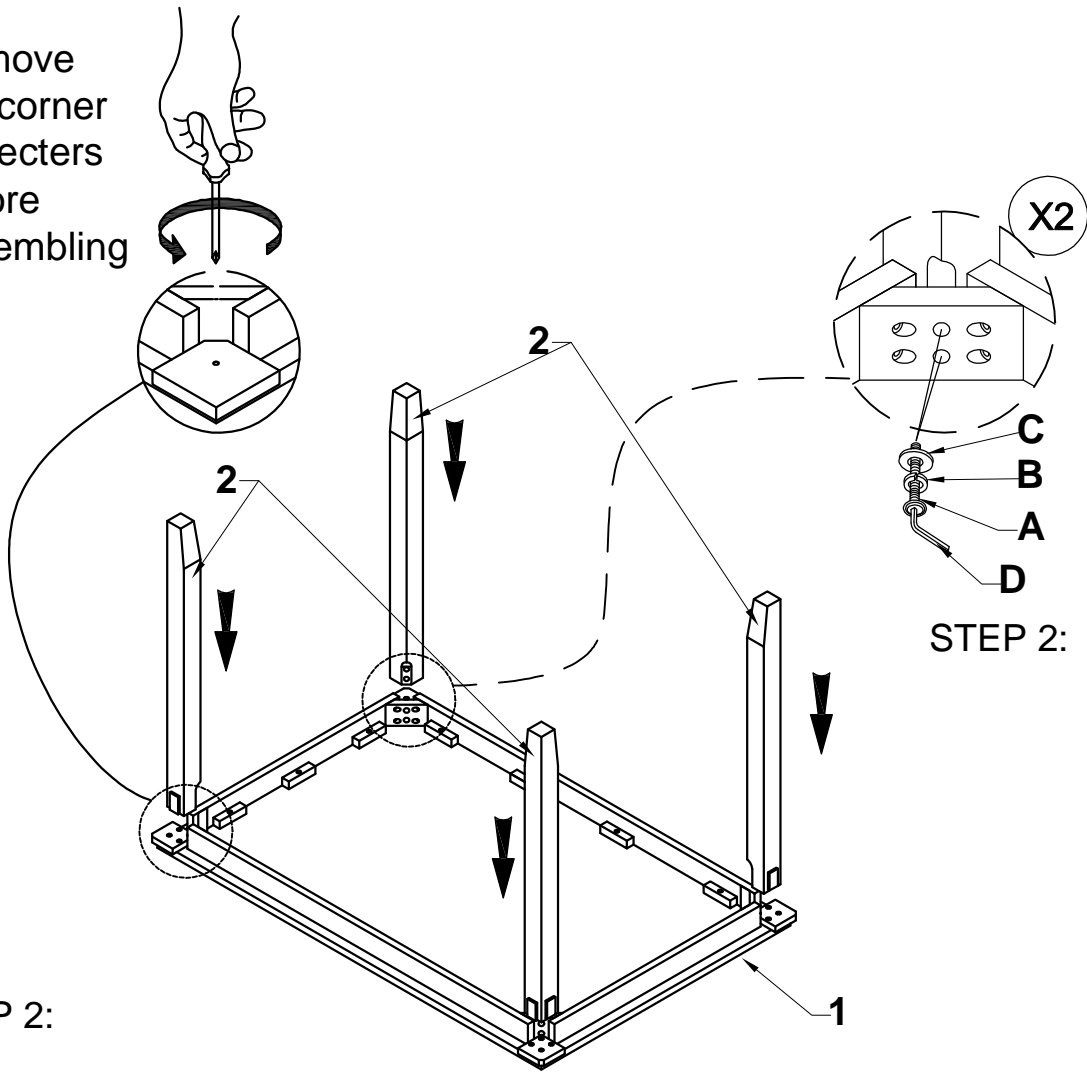

## STEP 2:

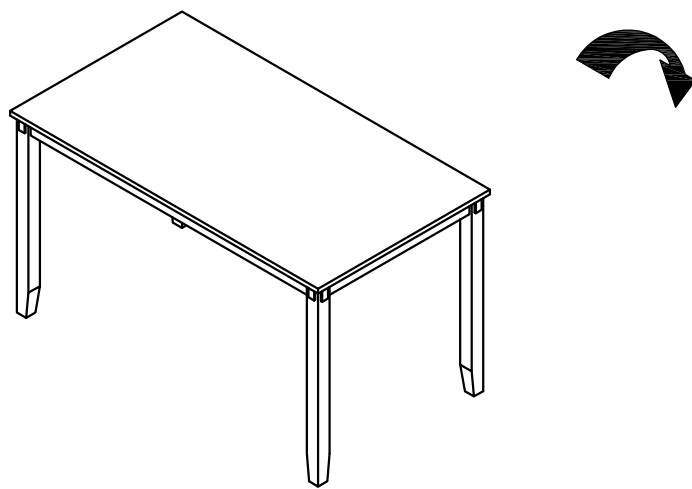

# ASSEMBLY INSTRUCTIONS

WF195048-DINING BENCH

## IMPORTANT NOTE :







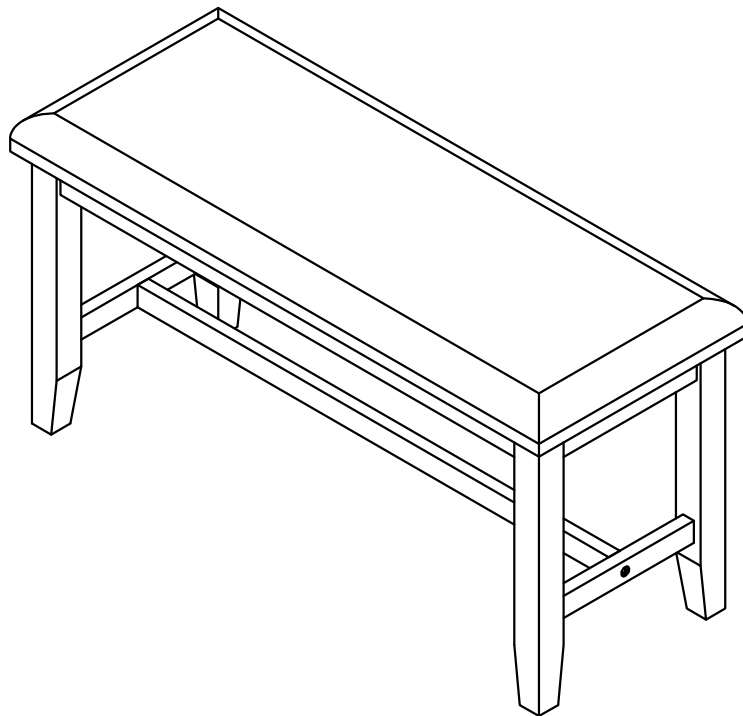

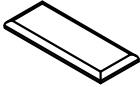

\*\* PLACE ALL PARTS ON A CLEAN AND SMOOTH SURFACE SUCH AS A RUG OR CARPET TO AVOID THE PARTS FROM BEING SCRATCHED.

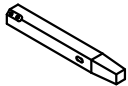
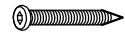
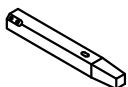
\*\* BEFORE YOU BEGIN, KINDLY FOLLOW THE ASSEMBLY INSTRUCTIONS STEP BY STEP.

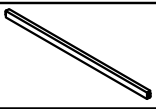
\*\*DO NOT TIGHTEN ALL SCREWS AND BOLTS UNTIL THE CHAIR IS FULLY SET-UP.



CARTONS ONLY ONE/ CARTONS SEULEMENT UN

PART LISTS				HARDWARE LISTS			
NO.	DESCRIPTION	SKETCH	Q'TY	NO.	DESCRIPTION	SKETCH	Q'TY
1	TABLE TOP		1 PC	A	BOLT Ø1/4" x 60mmL		8 PCS
2	LEG - L		2 PCS	B	BOLT Ø1/4" x 40mmL		2 PCS
3	LEG - R		2 PCS	C	SPRING WASHER Ø1/4" x 13mmL		8 PCS
4	MIDDLE STRECHER		1 PC	D	FLAT WASHER Ø1/4" x 19mmL		8 PCS
5	HORIZONTAL STRECHER		2 PCS	E	CREW Ø4 x 45mmL		4 PC
				F	ALLEN KEY		1 PC
							Not Included

## ASSEMBLY INSTRUCTIONS

### STEP 1:

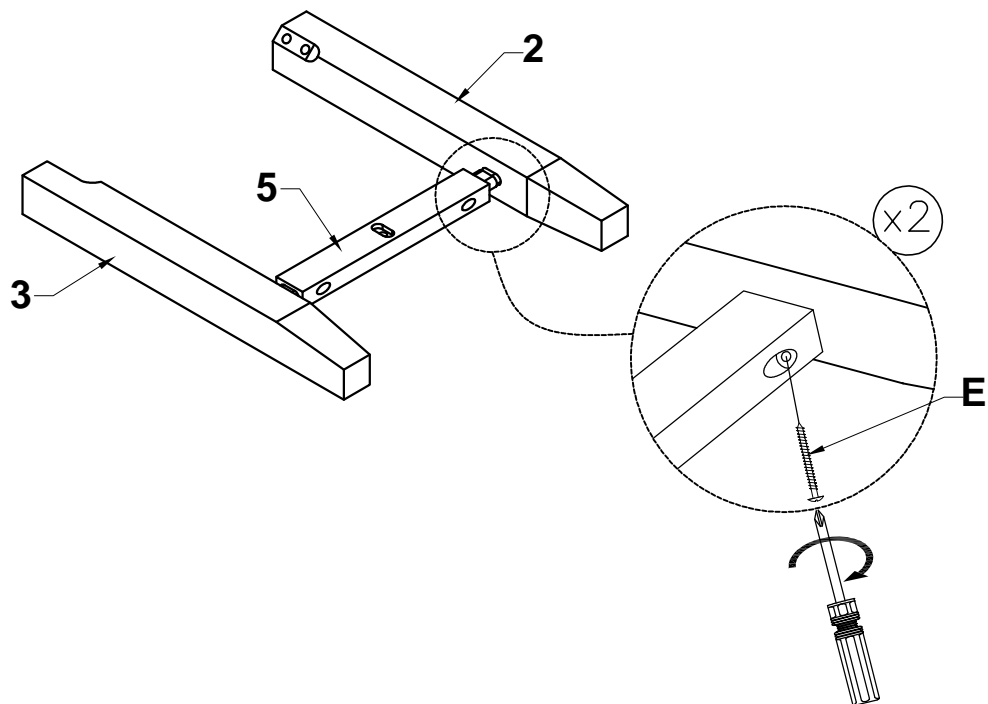

# ASSEMBLY INSTRUCTIONS

STEP 2:

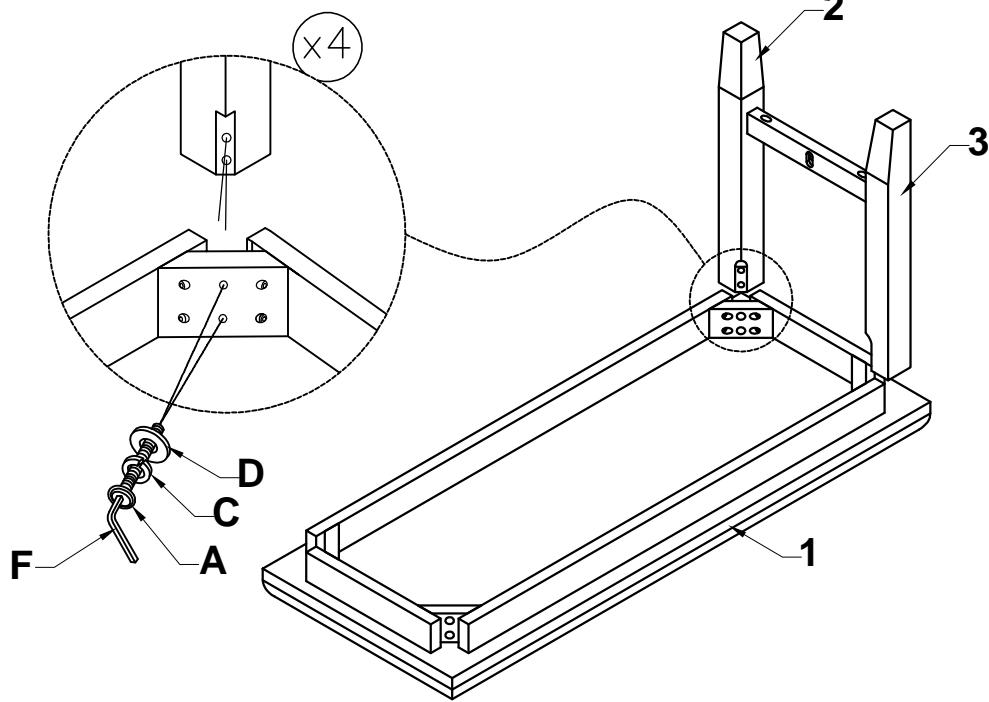

STEP 3:

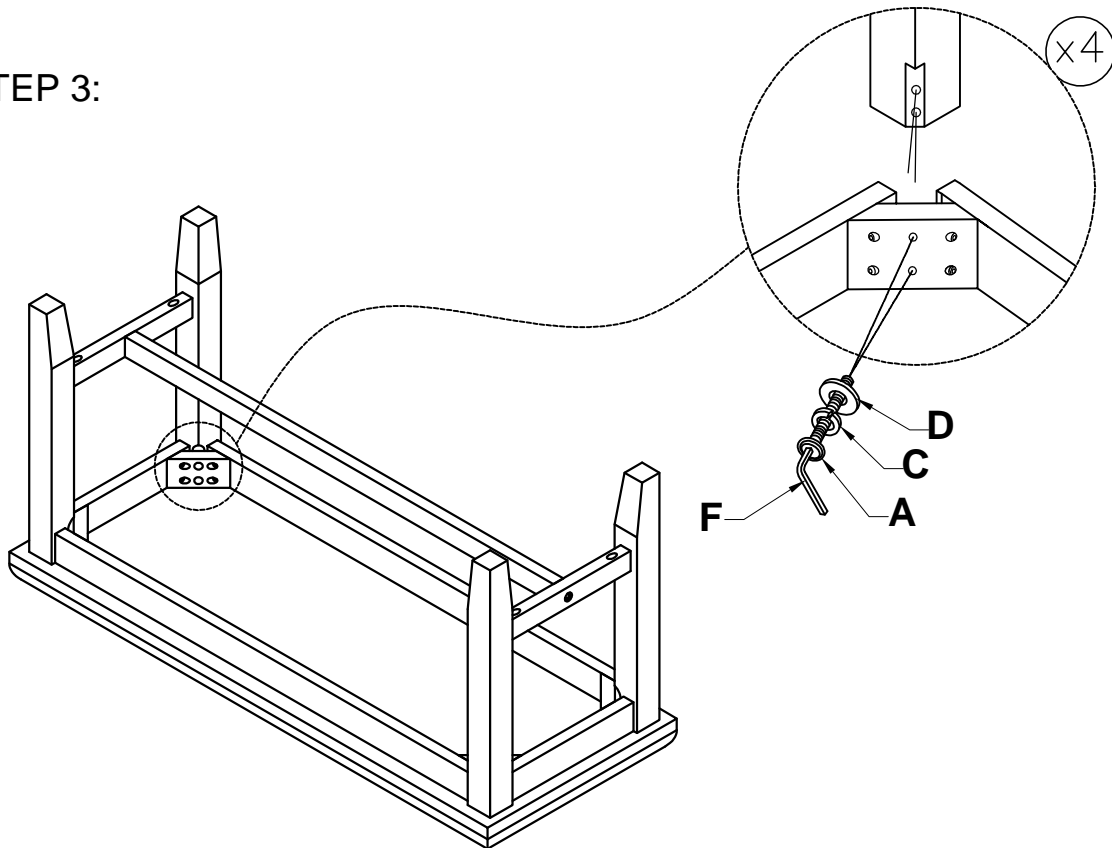

# ASSEMBLY INSTRUCTIONS

STEP 4:

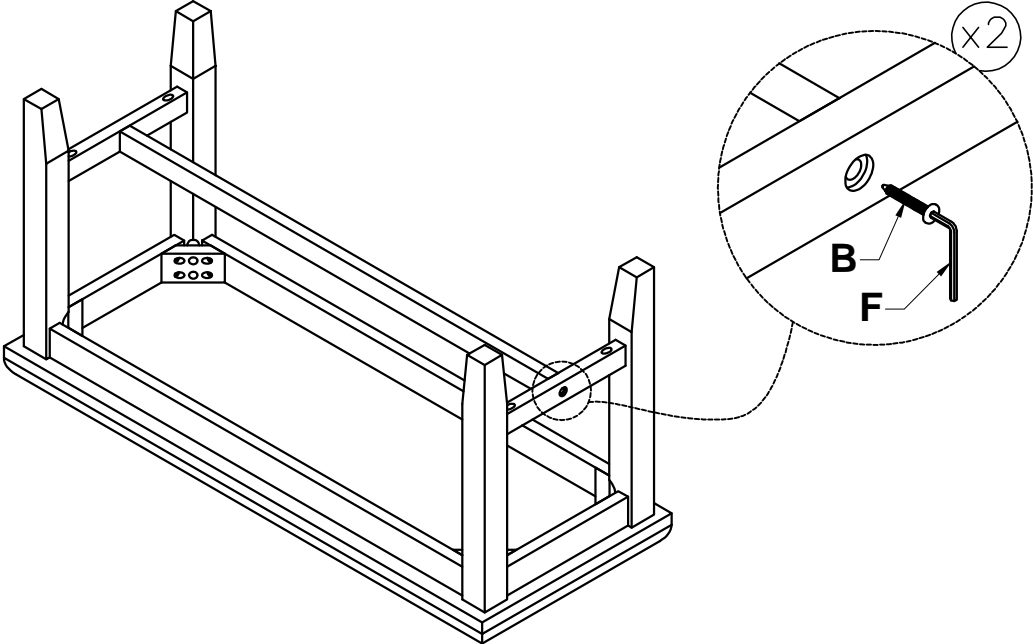

STEP 5:

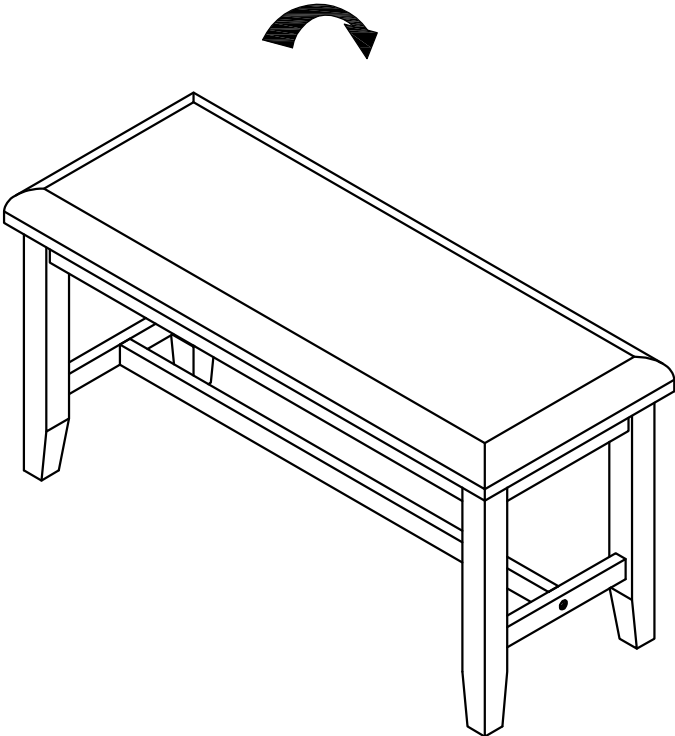

# ASSEMBLY INSTRUCTIONS







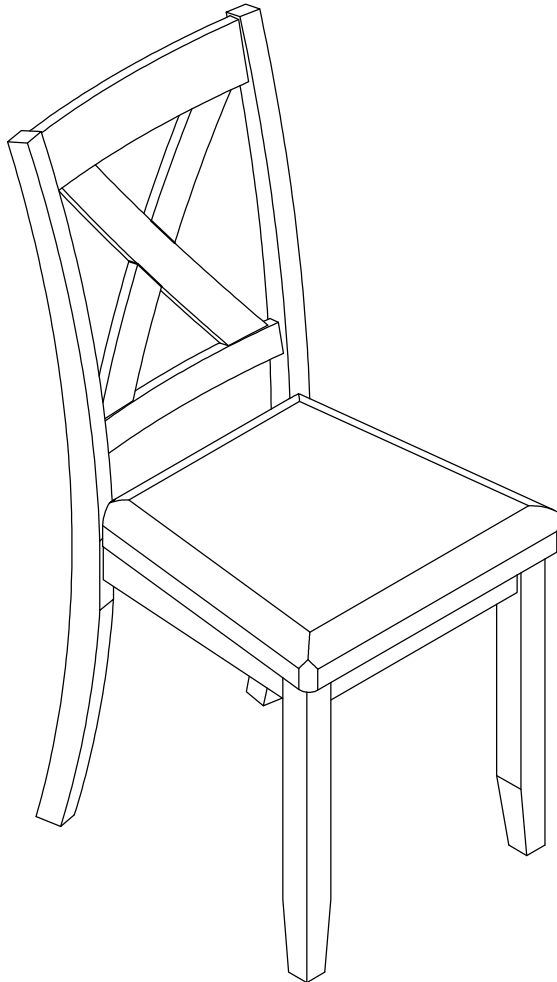

## WF195048-DINING CHAIR

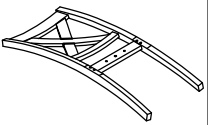
### IMPORTANT NOTE :

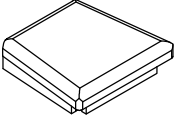
- \*\* PLACE ALL PARTS ON A CLEAN AND SMOOTH SURFACE SUCH AS A RUG OR CARPET TO AVOID THE PARTS FROM BEING SCRATCHED.
- \*\* BEFORE YOU BEGIN, KINDLY FOLLOW THE ASSEMBLY INSTRUCTIONS STEP BY STEP.
- \*\*DO NOT TIGHTEN ALL SCREWS AND BOLTS UNTIL THE CHAIR IS FULLY SET-UP.

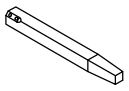

CARTONS ONLY ONE/ CARTONS SEULEMENT UN

PART LISTS				HARDWARE LISTS			
NO.	DESCRIPTION	SKETCH	Q'TY	NO.	DESCRIPTION	SKETCH	Q'TY
1	CHAIR BACK		4 PCS	A	BOLT Ø1/4" x 38mmL		8 PCS
2	SEAT FRAME		4 PCS	B	BOLT Ø1/4" x 60mmL		16 PCS
3	FRONT LEG		8 PCS	C	BOLT Ø1/4" x 75mmL		16 PCS
				D	SPRING WASHER Ø1/4" x 13mmL		40 PCS
				E	FLAT WASHER Ø1/4" x 19mmL		40 PCS
				F	ALLEN KEY		4 PCS

## ASSEMBLY INSTRUCTIONS

STEP 1:

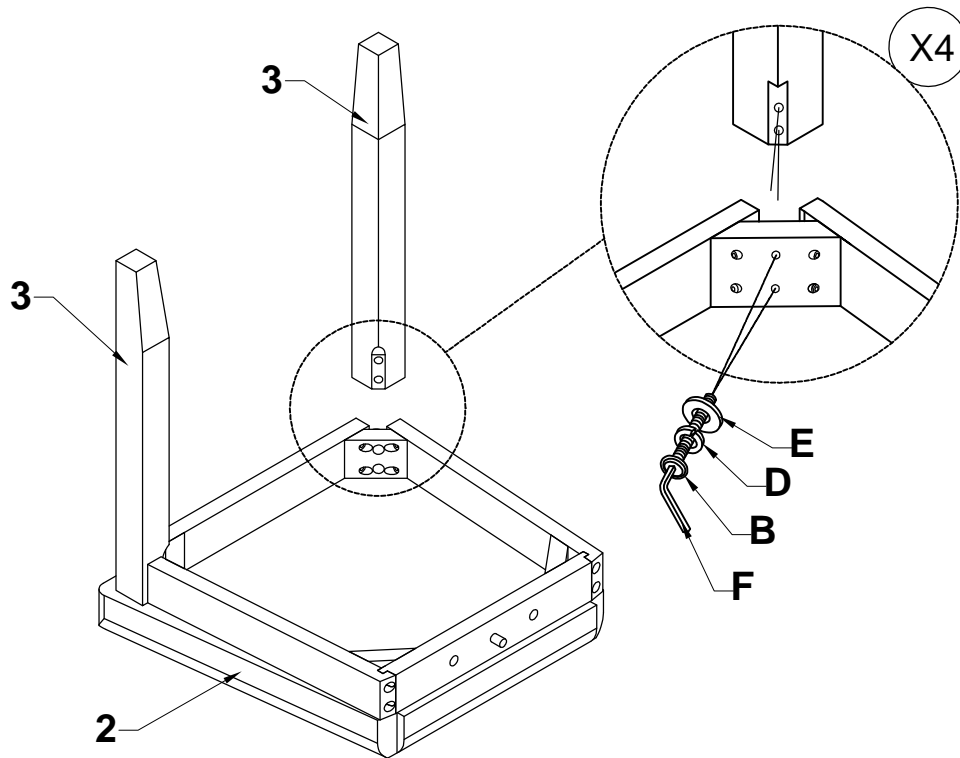



# ASSEMBLY INSTRUCTIONS

STEP 2:

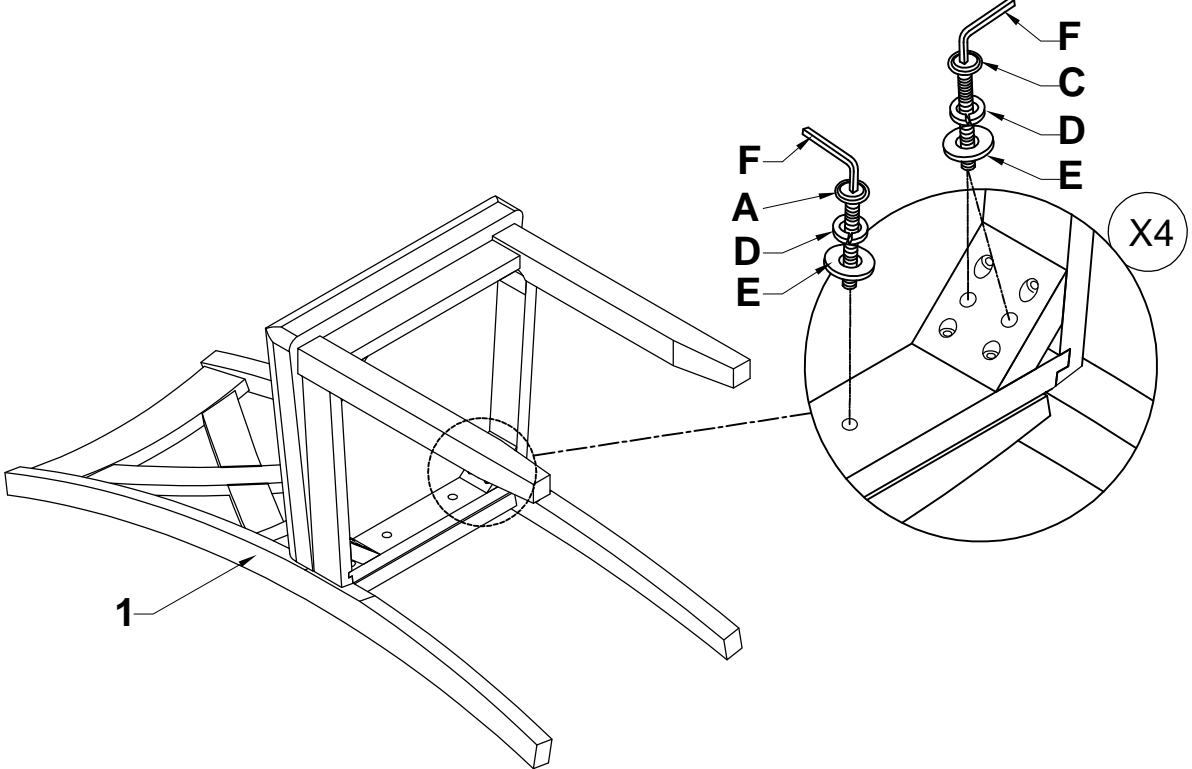

STEP 3:

