

# Basic Setup Dimensions

Place the set on level ground, not less than 6 ft-7 in [2 m] from any structure or obstruction such as a fence, garage, house, overhanging branches, laundry lines, or electrical wires.

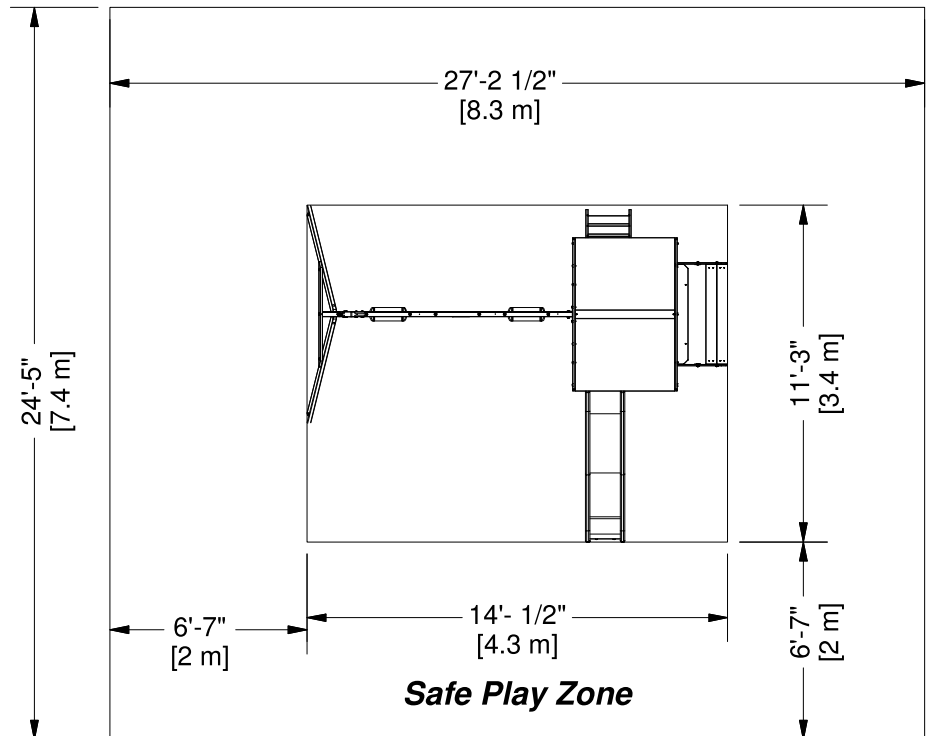

## **General Information:**

Your set has been designed and engineered for children only and for residential use only.  
A maximum of 150 lbs. per child is recommended for play activities designed for individual use.  
A maximum of 120 lbs. per child is recommended for play activities designed for multiple child use.  
A maximum of 9 children is recommended for this swing set.

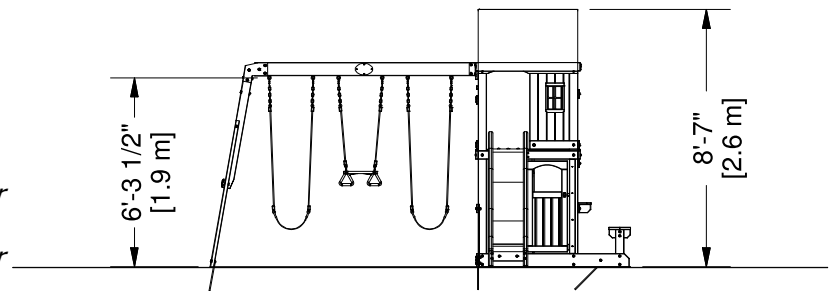

Safe play height: 14'-7" [4.4 m]  
Maximum fall height: 6'-3 1/2" [1.9 m]

## Important Assembly Notes

- 1) While assembling unit, take time before and after each step to make sure fort is level. If fort is not level, assembly will be difficult and improper assembly may result. Extra care must be taken to insure the fort is square.
- 2) Tighten bolts securely, tighten nuts on bolts flush to the tube or member, and place caps over exposed bolts snug to the nut.
- 3) Pay close attention to the ITEMS NEEDED FOR EACH STEP. They can be a valuable aid when sorting your wood and hardware. Assembly will be made easier if items are sorted by step.
- 4) Pay close attention to make sure you are using the correct hardware in the correct steps. Using incorrect hardware may result in improper assembly.
- 5) Whenever a T-nut is used, follow these directions. Place T-nut in pre-drilled hole. Tap in with hammer. Place bolt with washers in the opposite side. Hand tighten to make sure the bolt is in the T-nut. DO NOT over tighten.
- 6) Read the order of each step thoroughly. The written steps may include important information not shown in the illustrations.