

REPAIR SHEET

BRAND RYOBI		DESCRIPTION 18 Volt Brushless Power Head
MODEL NO. P20104 P20104VNM	MFG. NO. 315286001 315286101	

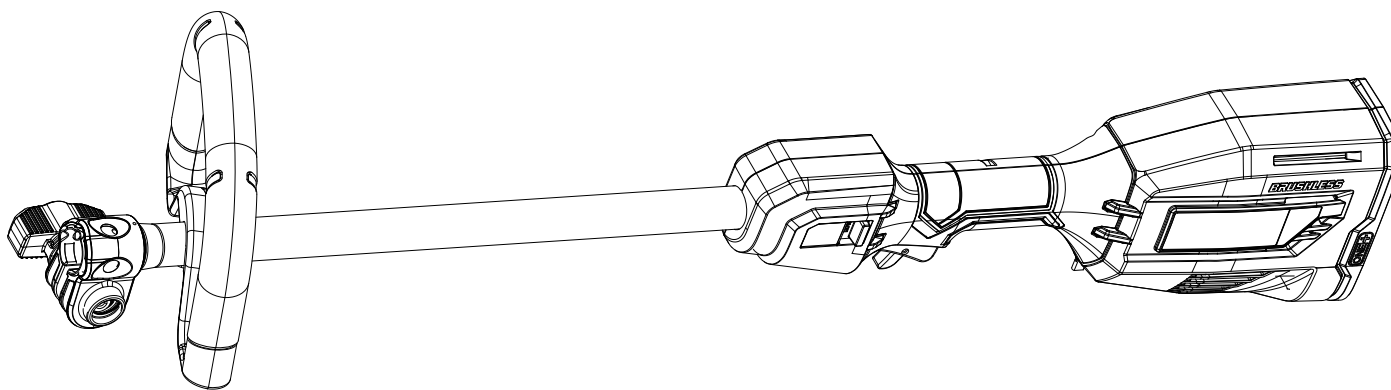

TTI OUTDOOR POWER EQUIPMENT, INC.

P.O. Box 1288, Anderson, SC 29622 ■ 1-800-525-2579 ■ www.ryobitools.com

11-22-21 (Rev:06)

The model number and manufacturing location will be found on a label attached to the product. Always mention this information in all communications regarding this product and when ordering parts.

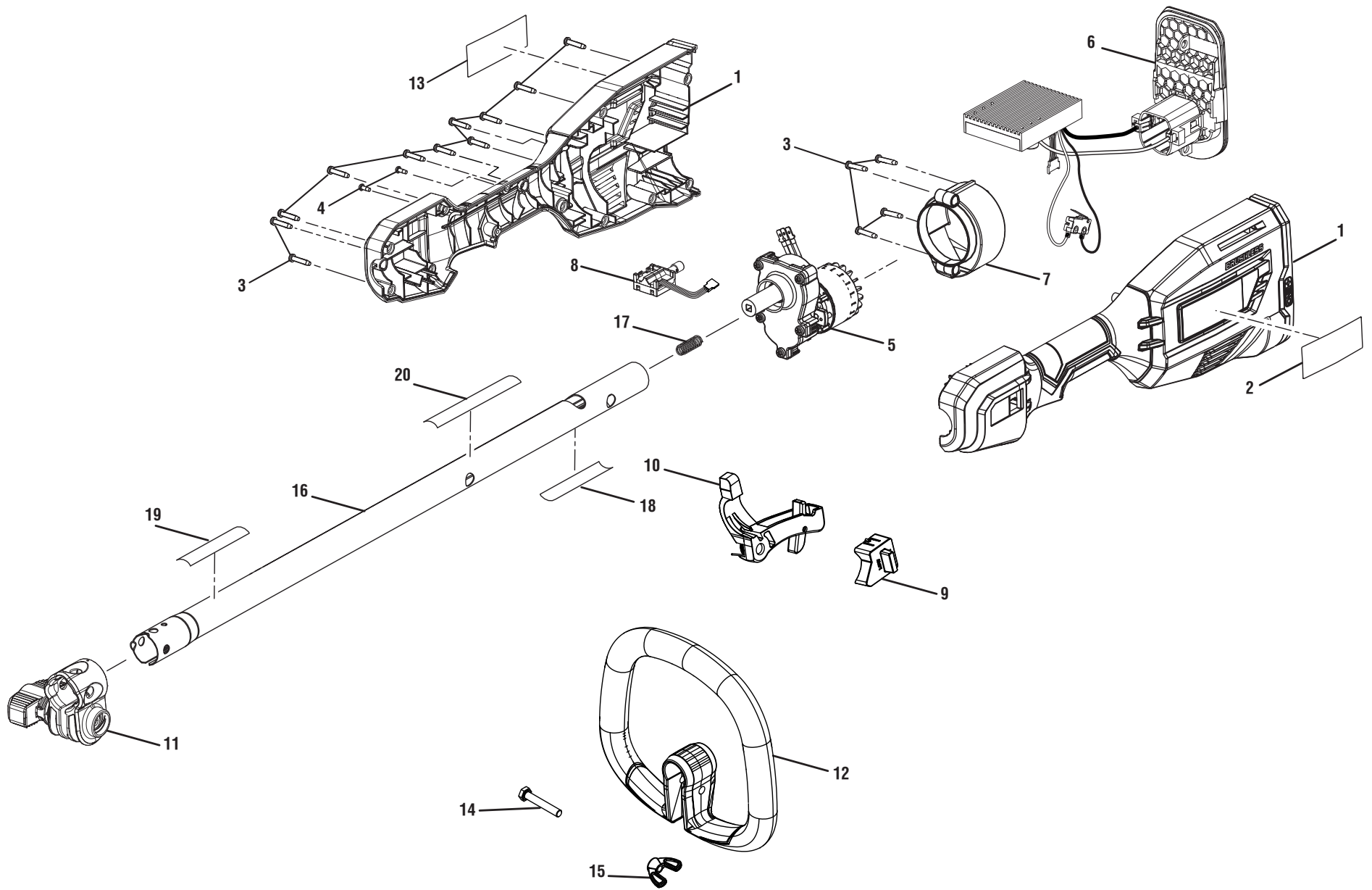



P20104/P20104VNM

PARTS LIST

KEY NO.	PART NO.	DESCRIPTION	QTY.
1	315989001	Rear Handle Assembly (Inc. Key No. 2 & 13)	1
2	940705585	Logo Label	1
3	661864007	Screw (M4 x 18 mm, T15 Torx Pan Hd.)	15
4	660203052	Screw (M3 x 8 mm, Pan Hd.)	2
5	313244003	Motor & Gear Box Assembly	1
6	292194001	Motor Controller & Switch Assembly	1
7	315990001	Motor Volute Assembly	1
8	760649001	Variable Speed Switch	1
9	539255001	Hi-Lo Switch Cover	1
10	314833001	Switch Trigger Assembly	1
11	315386001	Boom Clamp Assembly	1
12	308991003	Front Handle Assembly (Inc. Key Nos. 14-15)	1

KEY NO.	PART NO.	DESCRIPTION	QTY.
13	941588484	Data Label (P20104)	1
	941588902	Data Label (P20104VNM)	1
14	660643008	Screw (1/4-20 x 40 mm, Hex Hd.)	1
15	518949001	Wing Nut (1/4-20)	1
16	315991001	Boom Assembly (Inc. Key Nos. 18-20, P20104)	1
	316009001	Boom Assembly (Inc. Key Nos. 18-20, P20104VNM)	1
17	690140011	Compression Spring	1
18	941013005	Warning Label (French/Spanish)	1
19	941851150	Attachment Capable Label	1
20	941588795	Warning Icons Label	1
	Not Shown:		
	995000973	Operator's Manual	



P20104/P20104VNM

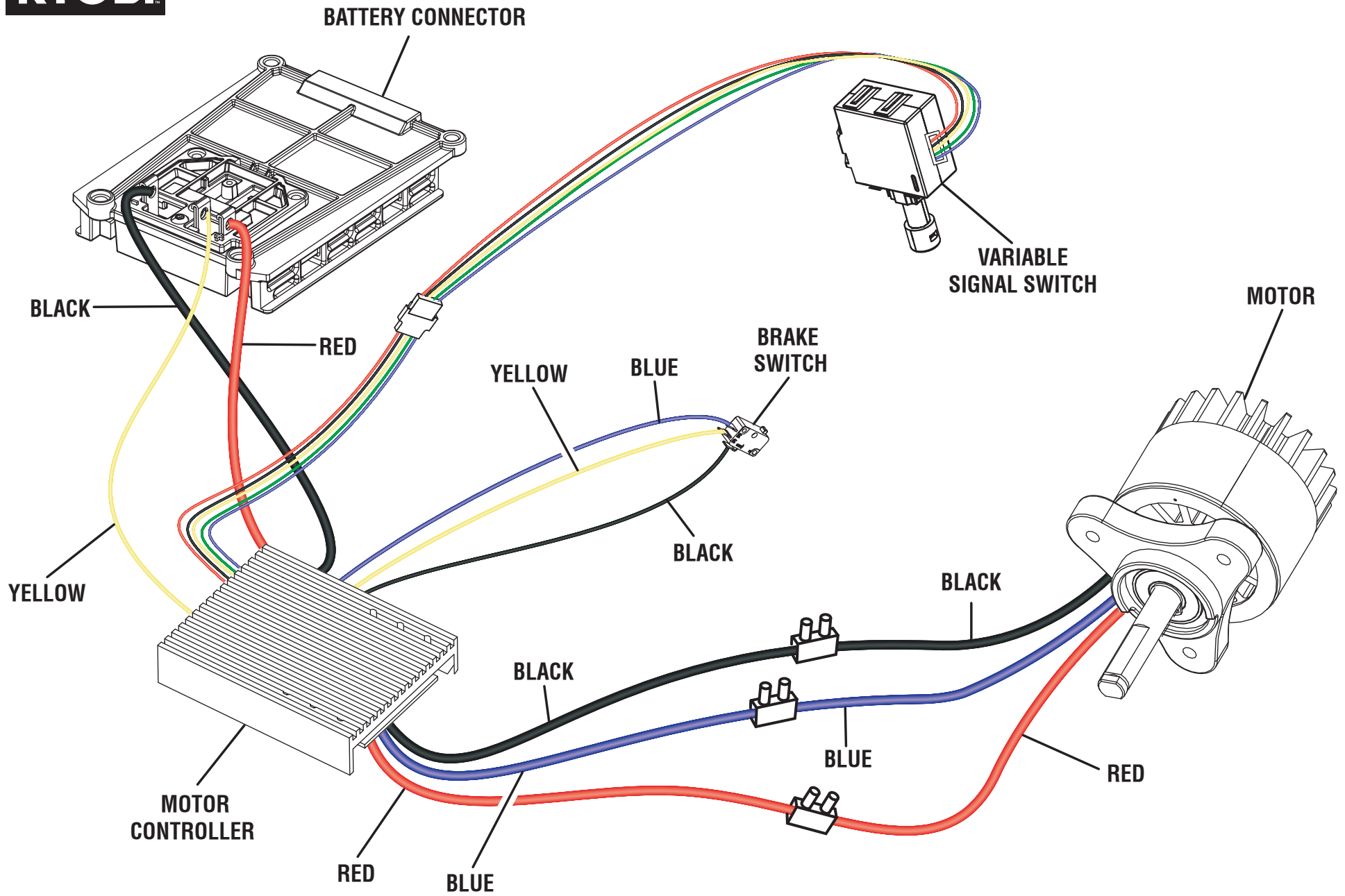

WIRING DIAGRAM

REPAIR SHEET

BRAND RYOBI		DESCRIPTION EXPAND-IT Straight Shaft Trimmer Attachment with 3-in-1 Trimmer Head Accessories
MODEL NO. RY15526 RY15526VNM	MFG. NO. 311247005 311247101	

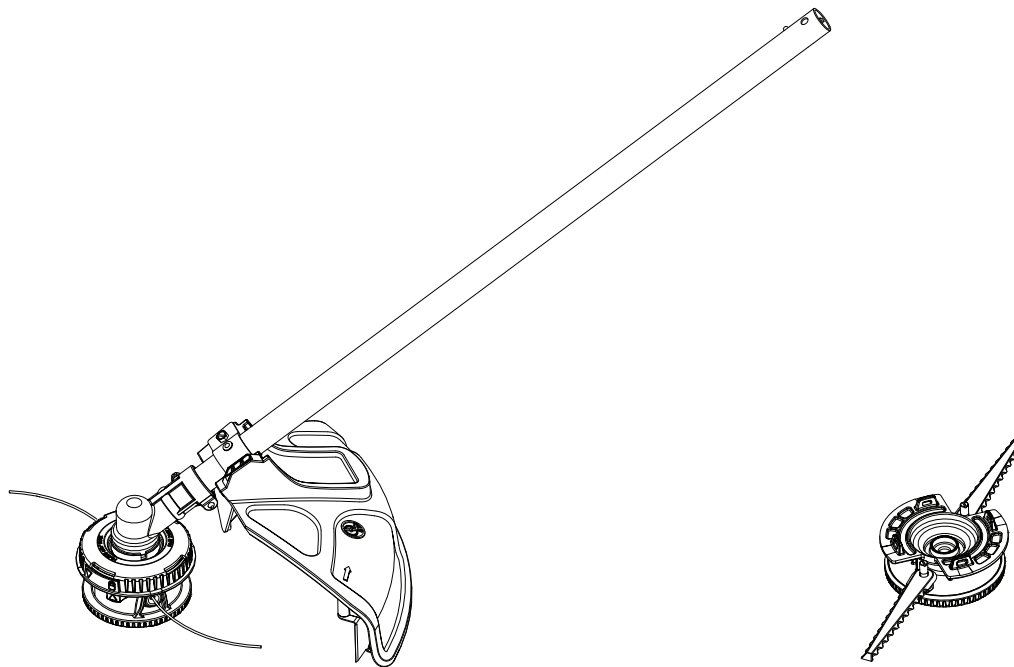

TECHTRONIC INDUSTRIES POWER EQUIPMENT

P.O. Box 1288, Anderson, SC 29622 ■ 1-800-525-2579 ■ www.ryobitools.com

7-6-21 (Rev:03)

The model number and manufacturing location will be found on a label attached to the product. Always mention this information in all communications regarding this product and when ordering parts.

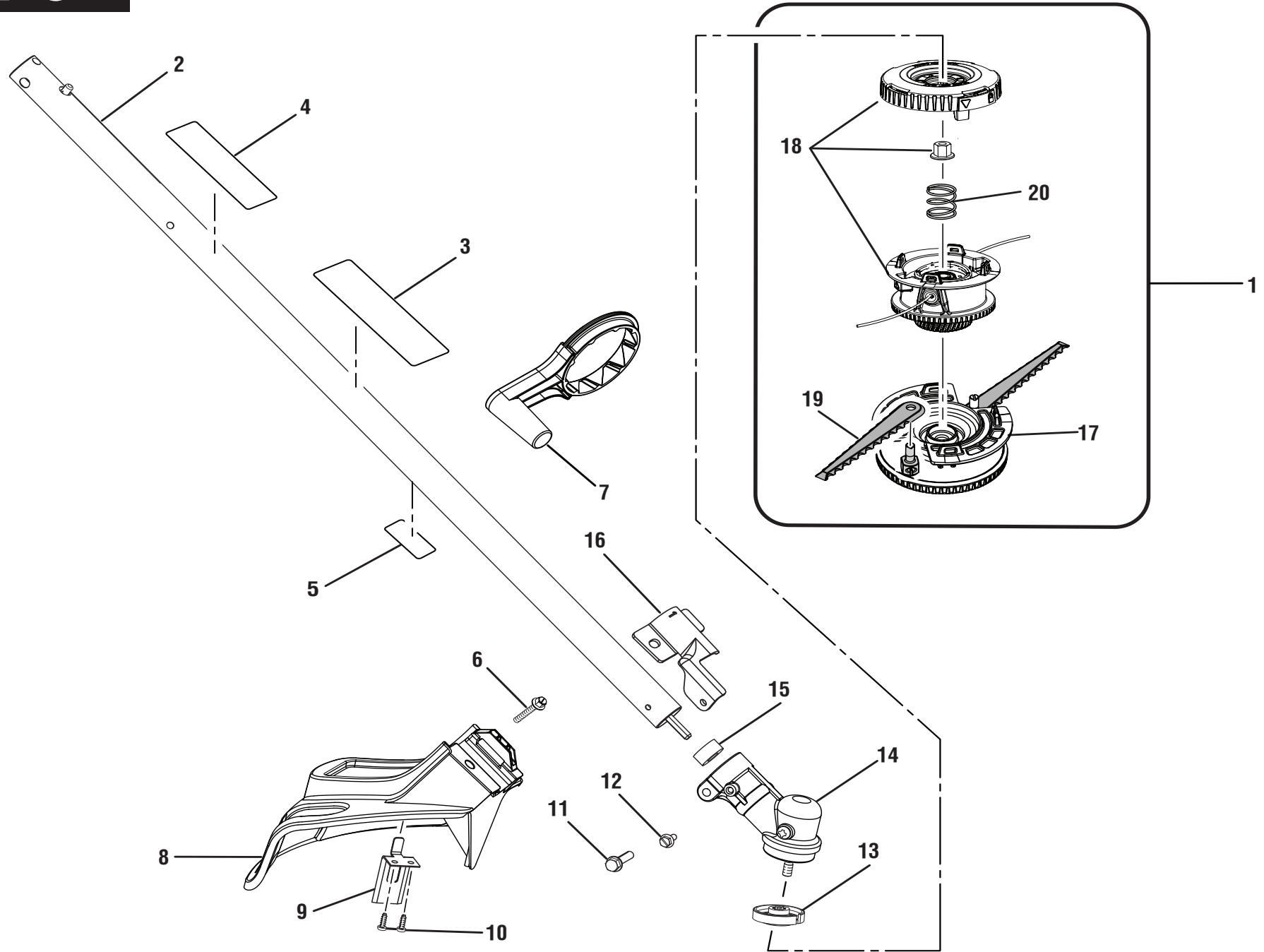



RY15526/RV15526VNM

PARTS LIST

KEY NO.	PART NO.	DESCRIPTION	QTY.
1	315614001	String Head Reel Assembly (Inc. Key Nos. 17-20)	1
2	311247008	Straight Shaft Assembly (RY15526, Inc. Key Nos. 3-5)	1
	311247009	Straight Shaft Assembly (RY15526VNM, Inc. Key Nos. 3-5)	1
3	940749005	Warning Icon Label	1
4	941851149	RYOBI EXPAND-IT Label	1
5	941588453	Data Label (RY15526)	1
	941588468	Data Label (RY15526VNM)	1
6	660738002	Screw (1/4-20 x 1-1/4 in., Hex Washer Hd.)	1
7	532048003	Crank Handle	1
8	313285005	Grass Deflector Assembly (Inc. Key Nos. 6 & 9-10)	1
9	638016003	Line Cut-off Blade	1
10	662148001	Screw (M4.5 mm x 1 mm, Pan Hd.)	2

KEY NO.	PART NO.	DESCRIPTION	QTY.
11	660642001	Screw (1/4-20 x 1-1/4 in., Hex Washer Hd.)	1
12	660641001	Screw (10-24 x 5/8 in., Hex Washer Hd.)	1
13	678011001	Flanged Washer	1
14	308210009	Gear Head	1
15	518367001	Spacer	1
16	638125001	Grass Deflector Clamp	1
17	314795003	Fixed Line (0.095 in.) and Blade Housing Assembly	1
18	314608005	Bump Feed Trimmer Head Assembly (Inc. Key No. 20)	1
19	537603002	Flail Blade	2
20	679958001	Compression Spring	1
	Not Shown:		
	995000924	Operator's Manual	