



STEEL PUMP JACK SYSTEM

NEW



STEEL PUMP JACK SYSTEM

- Exclusive Pole-Trak™ system with rugged hand crank and safety brake
- Slip-resistant foot lever with oversized boot strap
- Accommodates up to a 24" wide plank
- Economical and easy to operate
- OSHA and ANSI approved

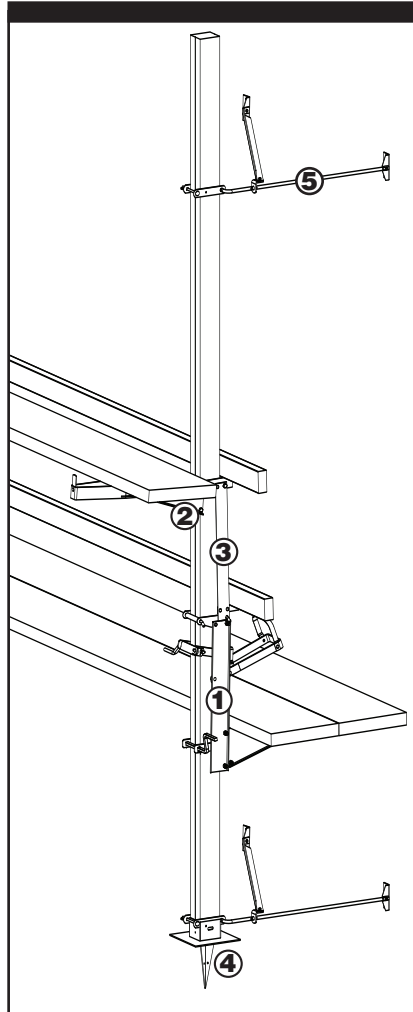

250^{RATED LOAD} lbs.

Combined Weight of User and Materials
Maximum load not to exceed rated load of either plank or pump jack.

Components shown

Description	Model Number	Carton Height (in)	Carton Width (in)	Carton Length (in)	Product Weight (lbs)	Qty Per Carton
① Steel Pump Jack	SPJ-100	26.1	6.3	19.3	23.0	1.00
② Steel Work Bench/Guardrail Combo	SPJ-WB	26.1	6.0	10.1	11.0	1.00
③ Steel Guardrail Holder	SPJ-GRH	26.2	5.8	6.8	5.5	1.00
④ Steel Pump Jack Pole Anchor (4 Pk)	SPJ-PA-4	8.8	24.5	17	23.0	4.00
⑤ Steel Pump Jack Foldable Support Brace	SPJ-SBF	1.8	6.9	48.7	7.0	1.00

NOTE: When working 10 ft and above, OSHA requires fall protection. Refer to product labels.

Easy Set Up*

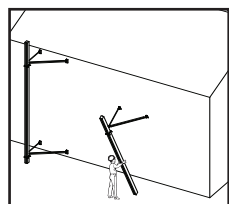

1 Install wood pole to work wall

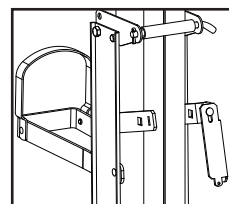

2 Install Steel Pump Jack to Wood pole

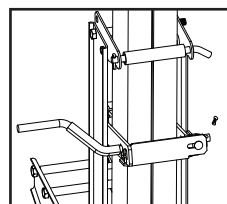

3 Close pole latch insert crank handle

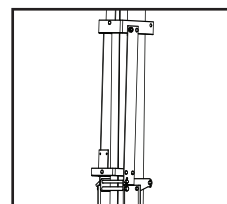

4 Install work bench to Pump Jack

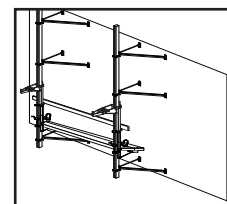

5 Install walk platform

*Note: Be sure to follow all safety and assembly instructions.



A10.8.2000



SYSTEM COMPONENTS

- Pump Jack
- Work Bench with Guardrail Holder
- Pole Anchor
- Foldable Brace



A10.8.2000



The #1 Brand in Professional Climbing Equipment.

A Versatile and Durable Steel Pump Jack System from the Most Trusted Name in Ladders

NEW

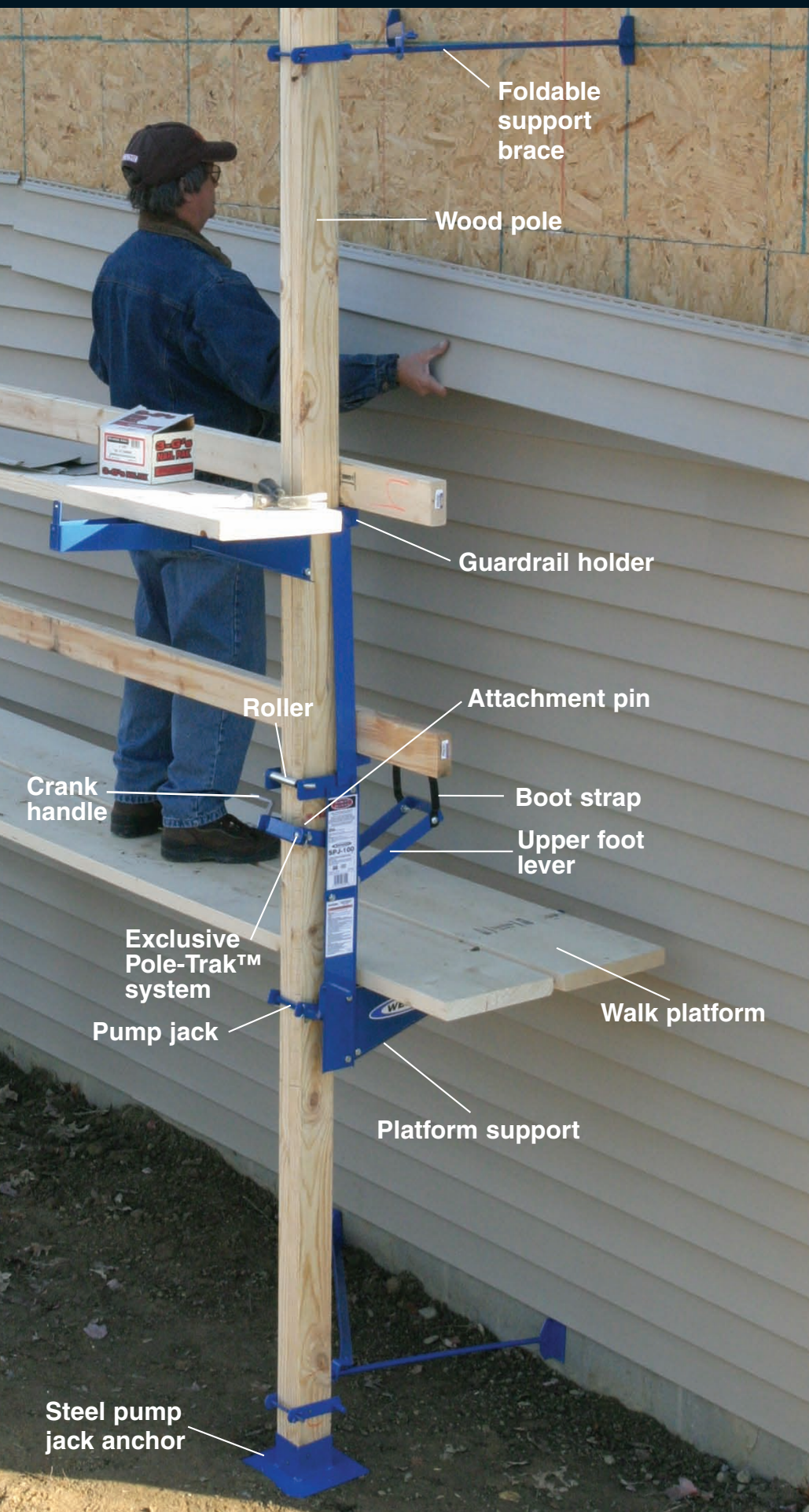

- Exclusive Pole-Trak™ system with rugged hand crank and safety brake



- Slip-resistant foot lever with oversized boot strap



- Accommodates up to a 24" wide plank

NOTE: When working 10 ft and above, OSHA requires fall protection. Refer to product labels.

SYSTEM COMPONENTS

Foldable Support Brace
model #SPJ-SBF

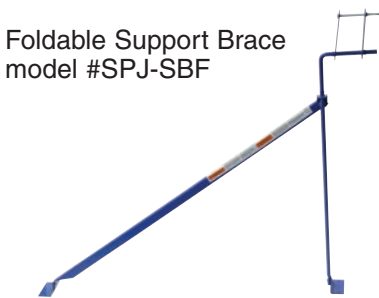

FOLDABLE BRACE (SPJ-SBF)

- Easily attaches to pole.
- Swivels to allow easy attachment.
- Provides triangular bracing (per OSHA).

Work Bench/
Guardrail holder
model #SPJ-WB



WORKBENCH/GUARDRAIL HOLDER (SPJ-WB)

- Easily attaches to pole and pump jack.
- Provides work surface at comfortable user height.
- Accommodates up to 20" wide platforms.

Guardrail Holder
model #SPJ-GRH

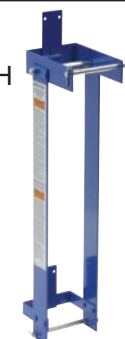

GUARDRAIL HOLDER (SPJ-GRH)

- Easily attaches to pole.
- Provides for 2x4 upper and mid-level guardrails (per OSHA).

Pump Jack
model #SPJ-100



PUMP JACK (SPJ-100)

- Powder coated steel for appearance and durability.
- Ribbed side plates for added strength and twist-resistance.
- Large boot strap for ease of use.
- Large, slip-resistant foot lever.
- Crank handle safety latch.
- Accommodates up to 24" wide platforms.

Pole Anchor
model #SPJ-PA-4



POLE ANCHOR (SPJ-PA-4)

- Easily attaches to pole.
- Provides a mudsill when firm base for pole is not available.