

MAINTENANCE

- Check for loose hardware, misalignment of parts, cracked, broken, or bent parts, and any other condition that may make your cart unsafe before each use.
- Keep your Service Cart clean by wiping the surfaces off regularly. Dirt, oil, grease, and other debris can cause a potential safety hazard.

We advise keeping this instruction manual, saving the receipt by attaching it to the instruction manual, and recording the purchase date in this space: _____ in case you need to exercise the 2-year warranty.

PARTS

Label	Part No.	Description	Qty.
A	73162-001	Cover	4
B	73162-002	Leg	8
C	73162-003	Shelf	3
D	73162-004	Nut M10	4
E	73162-005	Washer	4
F	73162-006	Holder	4
G	73162-007	Caster	2
H	73162-008	Locking Caster	2
I	73162-009	Hex Tool	1

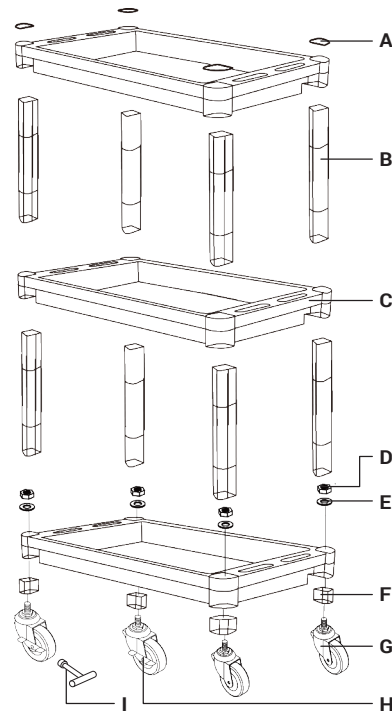

NEED HELP? CONTACT US!

Have product questions? Need technical support?
Please feel free to contact us at:

 **800-232-1195 (M-F 8-5 CST)**

 **techsupport@wenproducts.com**

 **WENPRODUCTS.COM**



3-SHELF POLYPROPYLENE SERVICE CART

CHARIOT UTILITAIRE

SPECIFICATIONS

Total Load Capacity	300 lb. (evenly distributed), 100 lb. on each shelf
Caster Information	4 x swivel casters (2 locking), 4 in. diameter, non-marring
Inner Shelf Dimensions	27 in. x 16-1/4 in. x 3-3/4 in. each
Overall Dimensions	32 in. x 18-1/2 in. x 36 in.

SAFETY

Warning: When using product, basic safety precautions should always be followed to reduce the risk of personal injury and damage to equipment.

- Keep work area clean and well lit. Cluttered and dimly lit areas invite injuries.
- When not in use, the Service Cart must be stored in a safe and clean location. Always secure products and keep out of reach of children.
- Check for damaged parts. Before using any product, any part that appears damaged should be carefully checked to determine that it will operate properly and perform its intended function. Replace or repair damaged or worn parts immediately.
- When servicing, use only identical replacement parts. The use of any other parts will void the warranty.
- Do not exceed the product's maximum load capacity of 300 lbs total; 100 lbs on each shelf, evenly distributed. Uneven weight distribution could cause tipping. Do not lean or climb on the Service Cart. Be aware of dynamic loading. Sudden load movement may briefly create excess load causing product failure.
- Only use on a flat surface capable of supporting the Service Cart and its maximum capacity load of 300 lbs. It is easy to lose control of the Service Cart if attempting to pull a load on a sloping or uneven surface.
- Do not allow children to play on, stand upon or climb on the Service Cart. The Service Cart is not for carrying people or animals.
- Always check hardware and assembled parts after assembling. All connections should be tight and hardware properly tightened.

WARNING: The warnings, cautions, and instructions discussed in this instruction manual cannot cover all possible conditions and situations that might occur. Always use common sense and caution when using the cart.

INSTRUCTION MANUAL

GET TO KNOW YOUR SERVICE CART

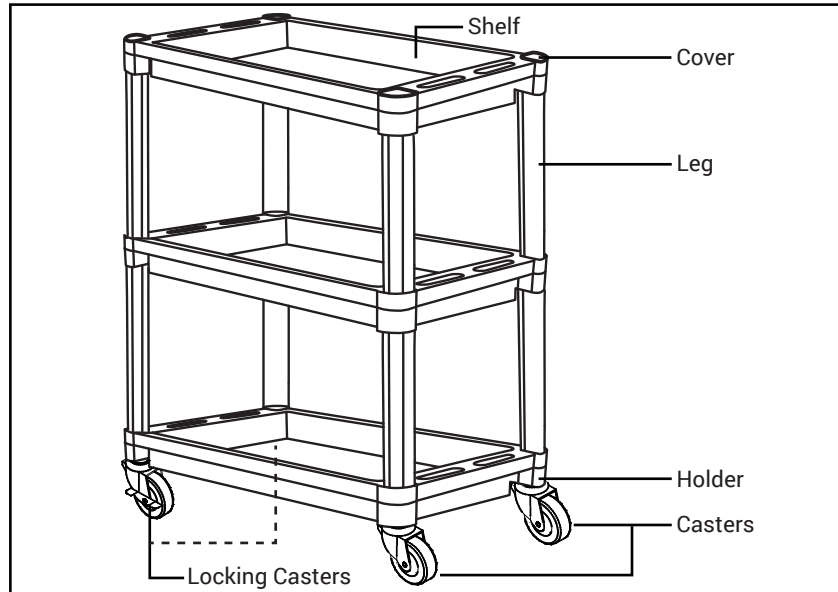

Fig. 1

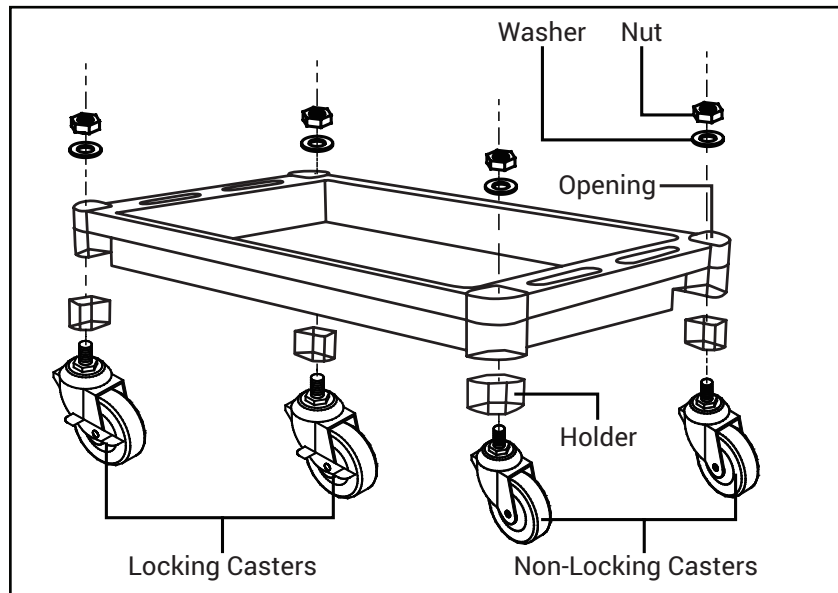

Fig. 2

ASSEMBLY

See the "Get to Know Your Service Cart" section on page 2.

1. Remove all parts and hex tool from the box.
 2. Place the bottom shelf upside down on the floor. Insert a holder into each of the four openings located on the corners of the shelf. Use a rubber hammer (not included) to secure them into place; there should be no space where the holders and base meet.
 3. Push a nut into the hex tool and set aside. Propping the shelf on its side, insert a caster through the hole in the holder and the base assembly. Place a washer onto the thread of the caster shank. Take the loaded hex tool and turn right to secure the nut onto the thread of the caster shank. Repeat with all four casters, making sure that the two non-locking casters and the two locking casters are on the same short sides as each other. See Fig. 2.
- NOTE:** To fully tighten the nuts, use a 17 mm socket and a socket wrench or impact driver.
4. Set the assembled base down with wheels touching the floor. Push four of the legs into the openings located on the corners of the base. Tap them into place with a rubber hammer.
 5. Take the middle shelf and align the legs with the openings in the corners of the shelf. Tap the four corners of the middle shelf with a rubber hammer to fasten the middle shelf to the legs.
 6. Push the remaining four legs into the openings located on the corners of the middle shelf. Tap them into place with a rubber hammer.
 7. Take the top shelf and align the legs with the openings in the corners of the shelf. Tap the four corners of the top shelf with a rubber hammer to fasten the top shelf to the legs.
 8. Push the four covers into the openings on the corners of the top shelf. Tap into place with a rubber hammer.
 9. Make sure all connections are flush and hardware is tightly fastened. Roll the cart to make sure that the casters roll properly. Your service cart is now ready for use. Do not exceed the total load capacity of 300 lbs, evenly distributed.

OPERATION

Before operation, you must assemble your Service Cart following the instructions above.

1. On a level surface, with the rear casters locked, begin placing objects onto your service cart. Remember to distribute items evenly; uneven weight distribution could cause the cart to tip.
2. Unlock the rear casters and begin rolling the cart.
3. When stopped, lock the rear casters and unload the cart.

NOTE: Make sure the locking casters are in the OFF/unlocked position before attempting to push the Service Cart, otherwise you can risk damaging the casters.