

SECTION 10: PARTS

Motor and Arbor

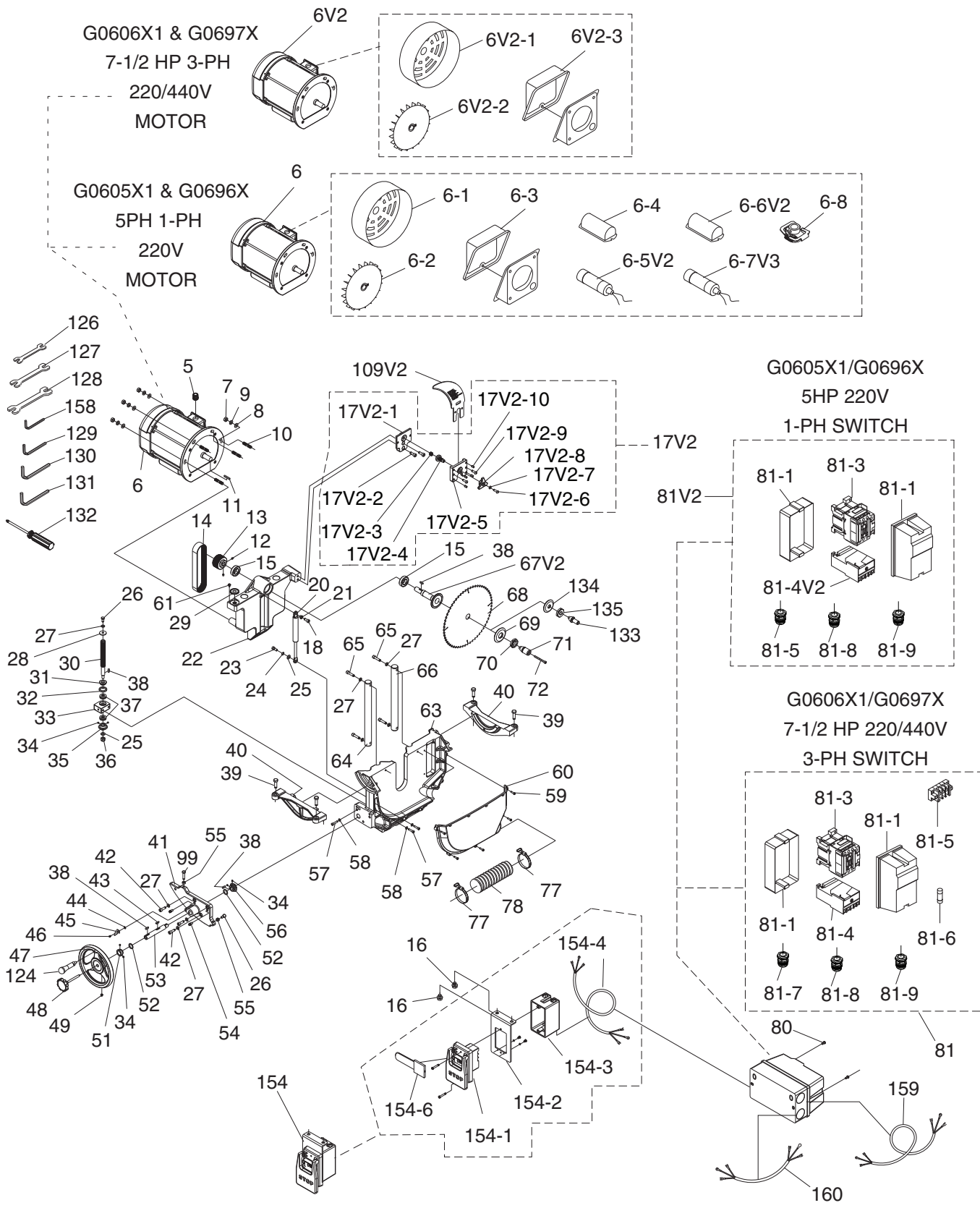

Motor and Arbor Parts List

REF	PART #	DESCRIPTION
5	P0605X1005	STRAIN RELIEF
7	PN02M	HEX NUT M10-1.5
8	PW04M	FLAT WASHER 10MM
9	PLW06M	LOCK WASHER 10MM
10	P0605X1010	MOTOR BOLT
11	PK02M	KEY 5 X 5 X 40
12	PSS03M	SET SCREW M6-1 X 8
13	P0605X1013	MOTOR PULLEY
14	P0605X1014	FLAT BELT 220-J12
15	P6005-2RS	BALL BEARING 6005 2RS
16	PFB15M	FLANGE BOLT M8-1.25 X 12
17V2	P0605X1017V2	MOUNTING BRACKET V2.01.10
17V2-1	P0605X1017V2-1	MOUNTING BRACKET BASE V2.01.10
17V2-2	PCAP14M	CAP SCREW M8-1.25 X 20
17V2-3	P0661044V2-3	COMPRESSION SPRING V2.01.10
17V2-4	P0661044V2-4	LOCKING BOLT V2.01.10
17V2-5	P0605X1017V2-5	MOUNTING BRACKET PLATE V2.01.10
17V2-6	PBHS06M	BUTTON HD CAP SCR M5-.8 X 12
17V2-7	PLW01M	LOCK WASHER 5MM
17V2-8	P0661044V2-8	HANDLE V2.01.10
17V2-9	PBHS16M	BUTTON HD CAP SCR M5-.8 X 16
17V2-10	PSS47M	SET SCREW M3-.5 X 10
18	PCAP14M	CAP SCREW M8-1.25 X 20
20	P0605X1020	STRUT
21	P0605X1021	BUSHING
22	P0605X1022	BRACKET
23	P0605X1023	STRUT SCREW
24	P0605X1024	WAVE WASHER 10MM
25	PW04M	FLAT WASHER 10MM
26	PB09M	HEX BOLT M8-1.25 X 20
27	PLW04M	LOCK WASHER 8MM
28	PW01M	FLAT WASHER 8MM
29	P0605X1029	BRUSH
30	P0605X1030	LEADSCREW
31	P0605X1031	BUSHING
32	P0605X1032	GASKET
33	P0605X1033	LEADSCREW BRACKET
34	PSS07M	SET SCREW M5-.8 X 5
35	P0605X1035	LEFT BEVEL GEAR
36	PLN10M	LOCK NUT M10-1.25
37	P51102	THRUST BEARING 51102
38	PK14M	KEY 5 X 5 X 18
39	PB14M	HEX BOLT M10-1.5 X 35
40	P0605X1040	TRUNNION SLIDE
41	P0605X1041	PLATE
42	PCAP31M	CAP SCREW M8-1.25 X 25
43	P0605X1043	WOODRUFF KEY 22 X 5
44	PTLW05M	EXT TOOTH WASHER 6MM
45	P0605X021	TILT ARROW POINTER
46	PS14M	PHLP HD SCR M6-1 X 12
47	P0605X1047	HANDWHEEL

REF	PART #	DESCRIPTION
48	P0605X1048	HANDWHEEL LOCK KNOB
49	PSS17	SET SCREW 5/16-18 X 5/16
51	P0605X1051	LOCK COLLAR
52	PW18M	FLAT WASHER 18MM
53	P0605X1053	BLADE HEIGHT HANDWHEEL SHAFT
54	P0605X1054	ALIGNMENT PIN
55	PN03M	HEX NUT M8-1.25
56	P0605X1056	RIGHT BEVEL GEAR
57	PCAP06M	CAP SCREW M6-1 X 25
58	PLW03M	LOCK WASHER 6MM
59	PS06M	PHLP HD SCR M5-.8 X 20
60	P0605X1060	BLADE COVER
61	PS09M	PHLP HD SCR M5-.8 X 10
63	P0605X1063	TRUNNION
64	P0605X1064	FRONT COLUMN
65	PCAP12M	CAP SCREW M8-1.25 X 40
66	P0605X1066	REAR COLUMN
67V2	P0605X1067V2	ARBOR SHAFT 1" V2.01.10
68	P0605X1068	BLADE
69	P0605X1069	ARBOR FLANGE
70	P0605X1070	ARBOR NUT 1"-10
71	P0605X1071	ARBOR EXTENSION 1"-10
72	PCAP189M	CAP SCREW M6-1 X 60 BLK C12.9 USA
77	P0605X1077	HOSE CLAMP 60-80MM
78	P0605X1078	DUST CHUTE HOSE 63 X 1000MM
80	PS01	PHLP HD SCR 10-24 X 1/2
99	PB20M	HEX BOLT M8-1.25 X 35
109V2	P0605X1109V2	RIVING KNIFE V2.01.10
124	P0605X1124	HANDWHEEL HANDLE
126	PWR810	WRENCH 8 X 10MM OPEN-END
127	PWR1113	WRENCH 11 X 13MM OPEN-END
128	PWR1417	WRENCH 14 X 17MM OPEN-END
129	PAW04M	HEX WRENCH 4MM
130	PAW05M	HEX WRENCH 5MM
131	PAW06M	HEX WRENCH 6MM
132	P0605X1132	PHILLIPS/STANDARD SCREWDRIVER
133	P0605X1133	ARBOR EXTENSION 5/8"-12 x 1-1/4"
134	P0605X1134	ARBOR FLANGE 5/8"
135	P0605X1135	ARBOR NUT 5/8"-12
154	P0605X1154	ON/OFF SWITCH ASSY 5HP-1HP
154-1	P0605X1154-1	ON/OFF PUSH BUTTON SWITCH
154-2	P0605X1154-2	ON/OFF SWITCH BRACKET
154-3	P0605X1154-3	ON/OFF SWITCH BOX
154-4	P0605X1154-4	ON/OFF SWITCH CORD 16AWG X 4C
154-6	T23243	SWITCH PADLOCK W/KEY
158	PAW03M	HEX WRENCH 3MM
159	P0605X1159	MOTOR CORD 12G 3C (G0605X1/96X)
159	P0606X1159	MOTOR CORD 12G 4C ST 600V (G0606X1/97X)
160	P0605X1160	POWER CORD 12G 3C 600V (G0605X1/96X)
160	P0606X1160	POWER CORD 12G 4C ST 600V (G0606X1/97X)
161	P0605X1161	GROUND WIRE 12G 1C 150MM



G0605X1/G0696X 5HP, 1-PH MOTOR

REF	PART #	DESCRIPTION
6	P0605X1006	MOTOR 5HP 220V 1-PH
6-1	P0605X1006-1	MOTOR FAN COVER
6-2	P0605X1006-2	MOTOR FAN
6-3	P0605X1006-3	WIRING JUNCTION BOX
6-4V2	P0605X1006-4V2	R CAPACITOR COVER V2.08.11
6-5V2	P0605X1006-5V2	R CAPACITOR 35M 450V V2.08.11
6-6V2	P0605X1006-6V2	S CAPACITOR COVER V2.05.12
6-7V3	P0605X1006-7V3	S CAPACITOR 250M 300V 1-3/4 X 3-1/2 V3.05.12
6-8	P0605X1006-8	CENTRIFUGAL SWITCH

G0605X1/G0696X 5HP, 1-PH MAG SWITCH

REF	PART #	DESCRIPTION
81V2	P0605X1081V2	MAG SWITCH SDE MP-30 V2.08.11
81-1	P0605X1081-1	MAG SWITCH FRONT/BACK COVER
81-3	P0605X1081-3	CONTACTOR SDE MA-30 220V
81-4V2	P0605X1081-4V2	OL RELAY SDE RA-30 18-26A V2.08.11
81-5	P0605X1081-5	STRAIN RELIEF MG20A-10-STB-XA
81-8	P0605X1081-8	STRAIN RELIEF MG20AS-10B-XA
81-9	P0605X1081-9	STRAIN RELIEF MG20AS-06B-XA

G0606X1/G0697X 7½HP, 3-PH MOTOR

REF	PART #	DESCRIPTION
6V2	P0606X1006	MOTOR 7-1/2 HP 220V/440V 3-PH V2.11.11
6V2-1	P0606X1006-1	MOTOR FAN COVER
6V2-2	P0606X1006-2	MOTOR FAN
6V2-3	P0606X1006-3	WIRING JUNCTION BOX

G0606X1/G0697X 7½HP, 3-PH MAG SWITCH

REF	PART #	DESCRIPTION
81	P0606X1081	MAGNETIC SWITCH ASSY MPE-30
81-1	P0606X1081-1	MAG SWITCH FRONT/BACK COVER
81-3	P0606X1081-3	CONTACTOR SDE MA-18 220V
81-4	P0606X1081-4	OL RELAY SDE RA-30 11-22A
81-5	P0606X1081-5	TRANSFORMER
81-6	P0606X1081-6	FUSE
81-7	P0606X1081-7	STRAIN RELIEF
81-8	P0606X1081-8	STRAIN RELIEF
81-9	P0606X1081-9	STRAIN RELIEF



Cabinet

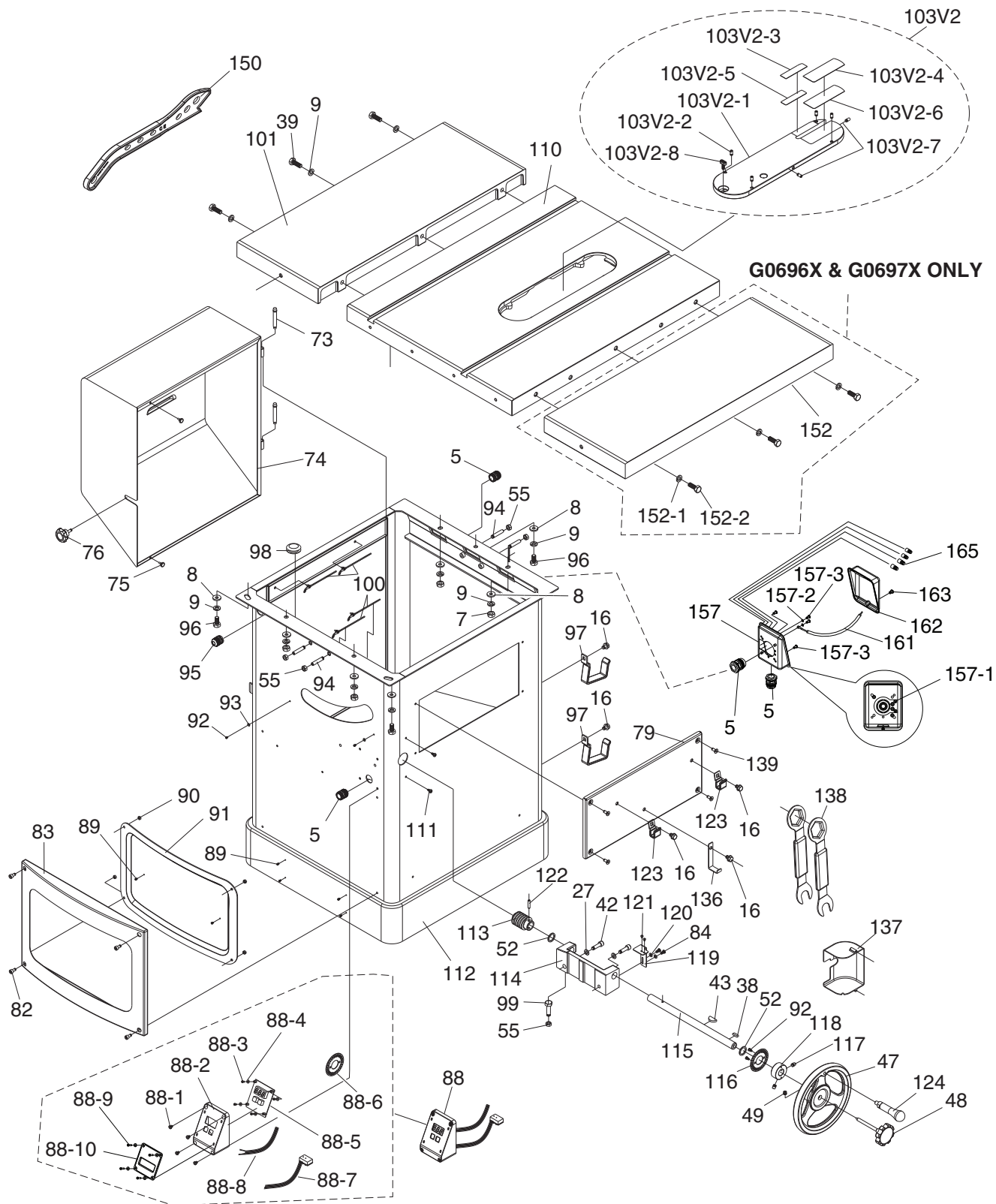

Cabinet Parts List

REF	PART #	DESCRIPTION
5	P0605X1005	STRAIN RELIEF
7	PN02M	HEX NUT M10-1.5
8	PW04M	FLAT WASHER 10MM
9	PLW06M	LOCK WASHER 10MM
16	PFB15M	FLANGE BOLT M8-1.25 X 12
27	PLW04M	LOCK WASHER 8MM
38	PK14M	KEY 5 X 5 X 18
39	PB14M	HEX BOLT M10-1.5 X 35
42	PCAP31M	CAP SCREW M8-1.25 X 25
43	P0605X1043	WOODRUFF KEY 22 X 5
47	P0605X1047	HANDWHEEL
48	P0605X1048	HANDWHEEL LOCK KNOB
49	PSS17	SET SCREW 5/16-18 X 5/16
52	PW18M	FLAT WASHER 18MM
55	PN03M	HEX NUT M8-1.25
73	P0605X1073	ALIGNMENT PIN
74	P0605X1074	MOTOR COVER
75	P0605X1075	RUBBER BUMPER
76	P0605X1076	LOCK KNOB M6-1 X 17
79	P0605X1079	RIGHT COVER
82	PCAP26M	CAP SCREW M6-1 X 12
83	P0605X1083	COVER
84	PS05M	PHLP HD SCR M5-.8 X 8
88	P0651083	DIGITAL SENSOR ASSEMBLY
88-1	PS05M	PHLP HD SCR M5-.8 X 8
88-2	P0651083-2	DIGITAL READOUT COVER
88-3	PS79M	PHLP HD SCR M3-.5 X 8
88-4	PW07M	FLAT WASHER 3MM
88-5	P0651083-5	CIRCUIT BOARD
88-6	P0651083-6	SENSOR PLATE
88-7	P0651083-7	DATA CORD 24 AWG X 450
88-8	P0651083-8	DIGITAL RDT CORD 18 AWG X 2C
88-9	PS50M	PHLP HD SCR M3-.5 X 12
88-10	P0605X1088-10	DIGITAL SENSOR COVER
89	PS79M	PHLP HD SCR M3-.5 X 8
90	PN06M	HEX NUT M5-.8
91	P0605X1091	PLATE
92	PS17M	PHLP HD SCR M4-.7 X 6
93	PW05M	FLAT WASHER 4MM
94	PSS42M	SET SCREW M8-1.25 X 50
95	P0605X1095	STRAIN RELIEF PGA13.5-11B
96	PB32M	HEX BOLT M10-1.5 X 25
97	P0651097	FENCE MOUNTING BRACKET
98	P0605X1098	STRAIN RELIEF

REF	PART #	DESCRIPTION
99	PB20M	HEX BOLT M8-1.25 X 35
100	P0605X1100	CHAIN
101	P0605X1101	LEFT EXTENSION WING
103V2	P0605X1103V2	TABLE INSERT ASSY V2.01.10
103V2-1	P0605X1103V2-1	PLATE V2.01.10
103V2-2	P0605X1103V2-2	BOLT V2.01.10
103V2-3	P0605X1103V2-3	LEFT PLATE V2.01.10
103V2-4	P0605X1103V2-4	RIGHT PLATE V2.01.10
103V2-5	P0605X1103V2-5	LEFT TAPE 19MM V2.01.10
103V2-6	P0605X1103V2-6	RIGHT TAPE 35MM V2.01.10
103V2-7	PSS04M	SET SCREW M6-1 X 12
103V2-8	P0661006V2	LOCK KNOB M5-.8 V2.01.10
110	P0605X1110	TABLE
111	PHTEK39M	TAP SCREW M4 X 12
112	P0605X1112	CABINET
113	P0605X1113	WORM GEAR
114	P0605X1114	BLADE TILT SHAFT BRACKET
115	P0605X1115	BLADE TILT SHAFT
116	P0651083-6	SENSOR PLATE
117	PSS16M	SET SCREW M8-1.25 X 10
118	P0605X1118	LOCK COLLAR
119	P0651112	L-PLATE
120	PW02M	FLAT WASHER 5MM
121	PHTEK30M	TAP SCREW M3 X 6
122	PRP27M	ROLL PIN 5 X 28
123	P0651106	MITER GAUGE MOUNTING BRKT
124	P0605X1124	HANDWHEEL HANDLE
136	P0651107	WRENCH MOUNTING BRACKET
137	P0651087	DUST COVER
138	P0651108	ARBOR WRENCH
139	PFH06M	FLAT HD SCR M6-1 X 20
150	P0661141	PUSH STICK
152	P0696X152	RIGHT EXTENSION WING
152-1	PLW06M	LOCK WASHER 10MM
152-2	PB14M	HEX BOLT M10-1.5 X 35
157	P0605X1157	JUNCTION BOX BASE
157-1	P0605X1157-1	GROUNDING LABEL
157-2	PTLW02M	EXT TOOTH WASHER 5MM
157-3	PS09M	PHLP HD SCR M5-.8 X 10
161	P0605X1161	GROUND WIRE 12G 1C 150MM
162	P0605X1162	JUNCTION BOX COVER
163	PS18	PHLP HD SCR 10-24 X 1/4
165	P0651161	WIRE NUT SW-P6H



Blade Guard

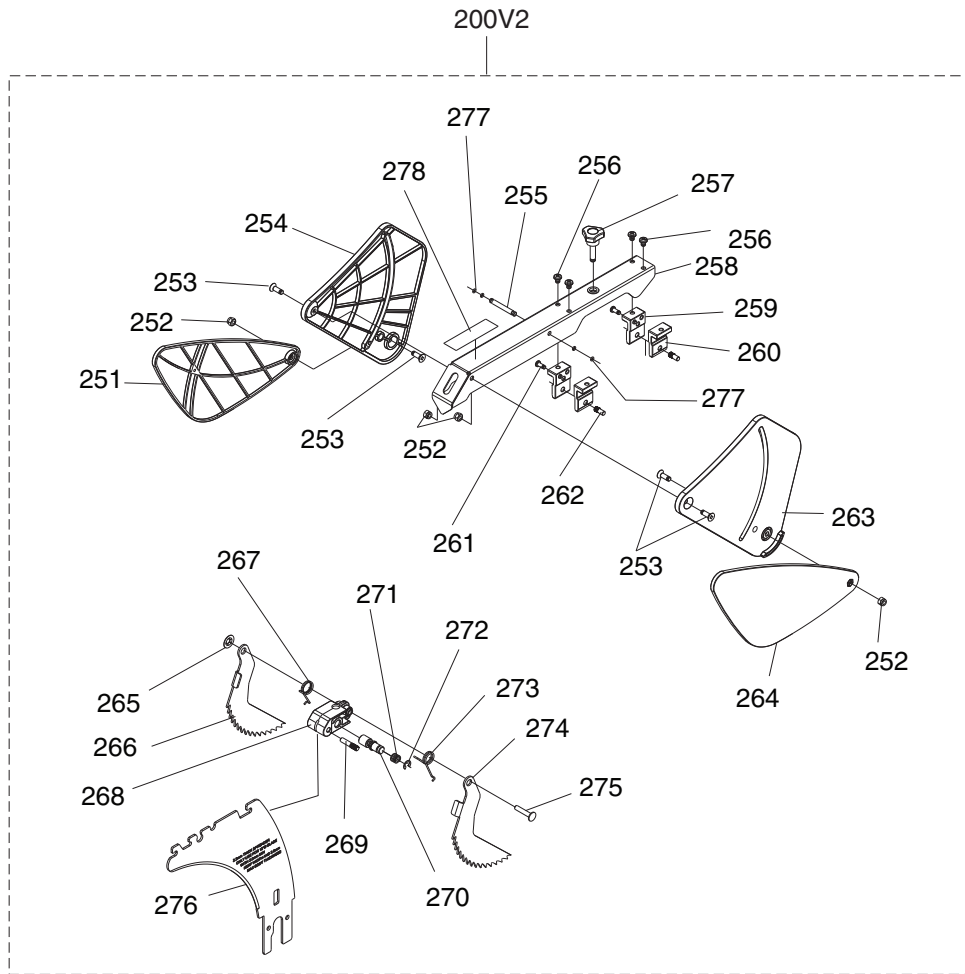

REF	PART #	DESCRIPTION
200V2	P0605X1200V2	BLADE GUARD ASSY V2.01.10
251	P0605X1200V2-1	LEFT PLATE V2.01.10
252	PLN02M	LOCK NUT M5-.8
253	PFH01M	FLAT HD SCR M5-.8 X 15
254	P0605X1200V2-4	LEFT COVER V2.01.10
255	P0661002V2-5	ROD CENTER PIN V2.01.10
256	PS19M	PHLP HD SCR M5-.8 X 6
257	P0661002V2-7	KNOB BOLT V2.01.10
258	P0605X1200V2-8	ROD V2.01.10
259	P0661002V2-9	LEFT BRACKET V2.01.10
260	P0661002V2-10	RIGHT BRACKET V2.01.10
261	PBHS24M	BUTTON HD CAP SCR M4-.7 X 10
262	P0661002V2-12	MOUNTING PIN V2.01.10
263	P0605X1200V2-13	RIGHT COVER V2.01.10
264	P0661002V2-14	RIGHT PLATE V2.01.10

REF	PART #	DESCRIPTION
265	P0661002V2-15	PUSH NUT 4MM V2.01.10
266	P0605X1200V2-16	LEFT PAWL V2.01.10
267	P0661002V2-17	RIGHT TORSION SPRING V2.01.10
268	P0661002V2-18	PAWL MOUNTING BRKT V2.01.10
269	P0661002V2-19	MOUNTING BRKT PIN V2.01.10
270	P0661002V2-20	MOUNTING BRKT SHFT V2.01.10
271	P0661002V2-21	SHAFT SPRING V2.01.10
272	PEC07M	E-CLIP 7MM
273	P0661002V2-23	LEFT TORSION SPRING V2.01.10
274	P0605X1200V2-24	RIGHT PAWL V2.01.10
275	P0661002V2-25	RIGHT PAWL SHAFT V2.01.10
276	P0605X1200V2-26	SPREADER V2.01.10
277	PORP003	O-RING 2.8 X 1.9 P3
278	P0661002V2-28	AMPUTATION HAZ LABEL V2.01.10



Fence

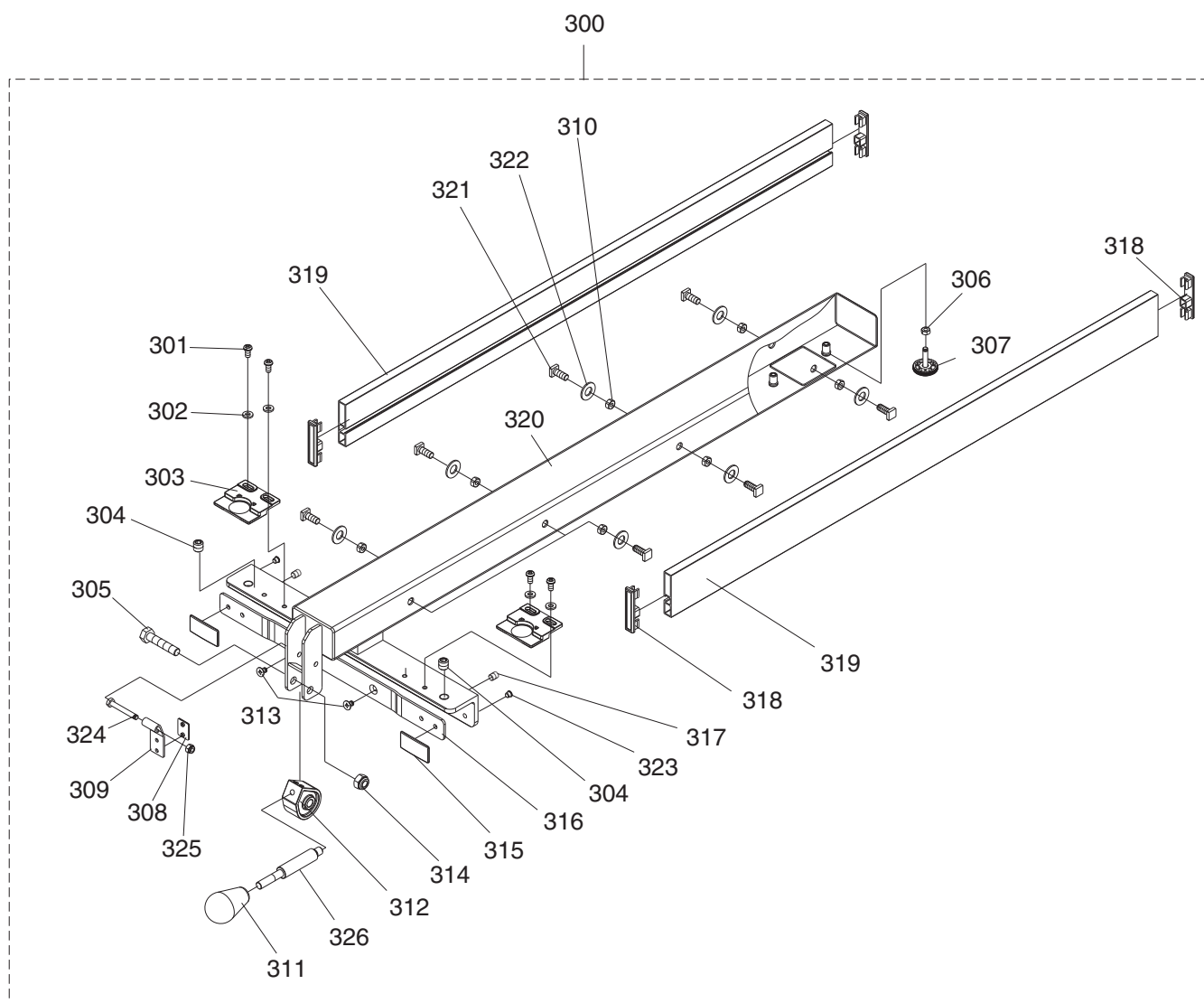

REF	PART #	DESCRIPTION
300	P0605X1300	FENCE ASSEMBLY
301	PS14M	PHLP HD SCR M6-1 X 12
302	PW03M	FLAT WASHER 6MM
303	P0605X1303	POINTER
304	P0605X1304	PLASTIC SET SCREW
305	PB73M	HEX BOLT M10-1.5 X 50
306	PN01M	HEX NUT M6-1
307	P0605X1307	REAR RAIL WHEEL
308	P0605X1308	PLATE
309	P0605X1309	BRACKET
310	PN03M	HEX NUT M8-1.25
311	P0605X1311	FENCE HANDLE
312	P0605X1312	CAM ASSEMBLY
313	PFH04M	FLAT HD SCR M6-1 X 8

REF	PART #	DESCRIPTION
314	PLN05M	LOCK NUT M10-1.5
315	P0605X1315	PLATE
316	P0605X1316	CLAMPING BRACKET
317	PSS20M	SET SCREW M8-1.25 X 8
318	P0605X1318	PLATE CAP
319	P0605X1319	FENCE PLATE
320	P0605X1320	FENCE
321	P0605X1321	T-BOLT M8-1.25 X 20
322	PW01M	FLAT WASHER 8MM
323	P0605X1323	BLOCK
324	PB71M	HEX BOLT M6-1 X 45
325	PLN03M	LOCK NUT M6-1
326	P0605X1326	SHAFT



Miter Gauge

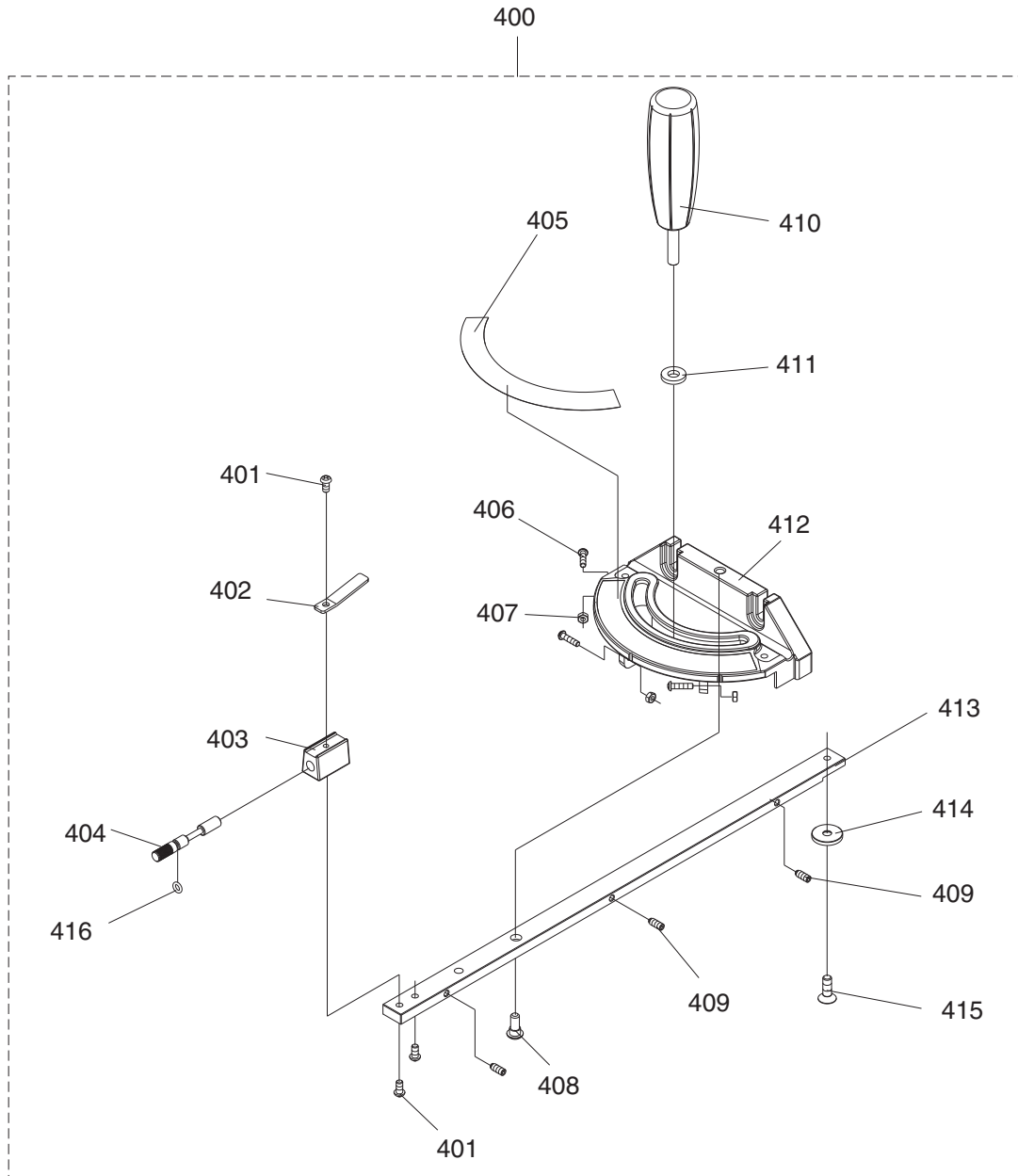

REF	PART #	DESCRIPTION
400	P0605X1400	MITER GAUGE ASSEMBLY
401	PS06	PHLP HD SCR 10-24 X 3/8
402	P0605X1402	POINTER
403	P0605X1403	BLOCK
404	P0605X1404	SHAFT
405	P0605X1405	MITER GAUGE LABEL
406	PS25	PHLP HD SCR 8-32 X 5/8
407	PN14	HEX NUT 8-32
408	P0605X1408	STEP SCREW 1/4-20 X 1/2

REF	PART #	DESCRIPTION
409	PSS53M	SET SCREW M5-.8 X 12
410	P0605X1410	MITER GAUGE HANDLE
411	PW01M	FLAT WASHER 8MM
412	P0605X1412	MITER GAUGE BODY
413	P0605X1413	PLATE
414	P0605X1414	GUIDE PLATE
415	PFH9M	FLAT HD SCR M6-1 X 6
416	PORP005	O-RING 4.8 X 1.9 P5



Rails (Model G0696X/G0697X)

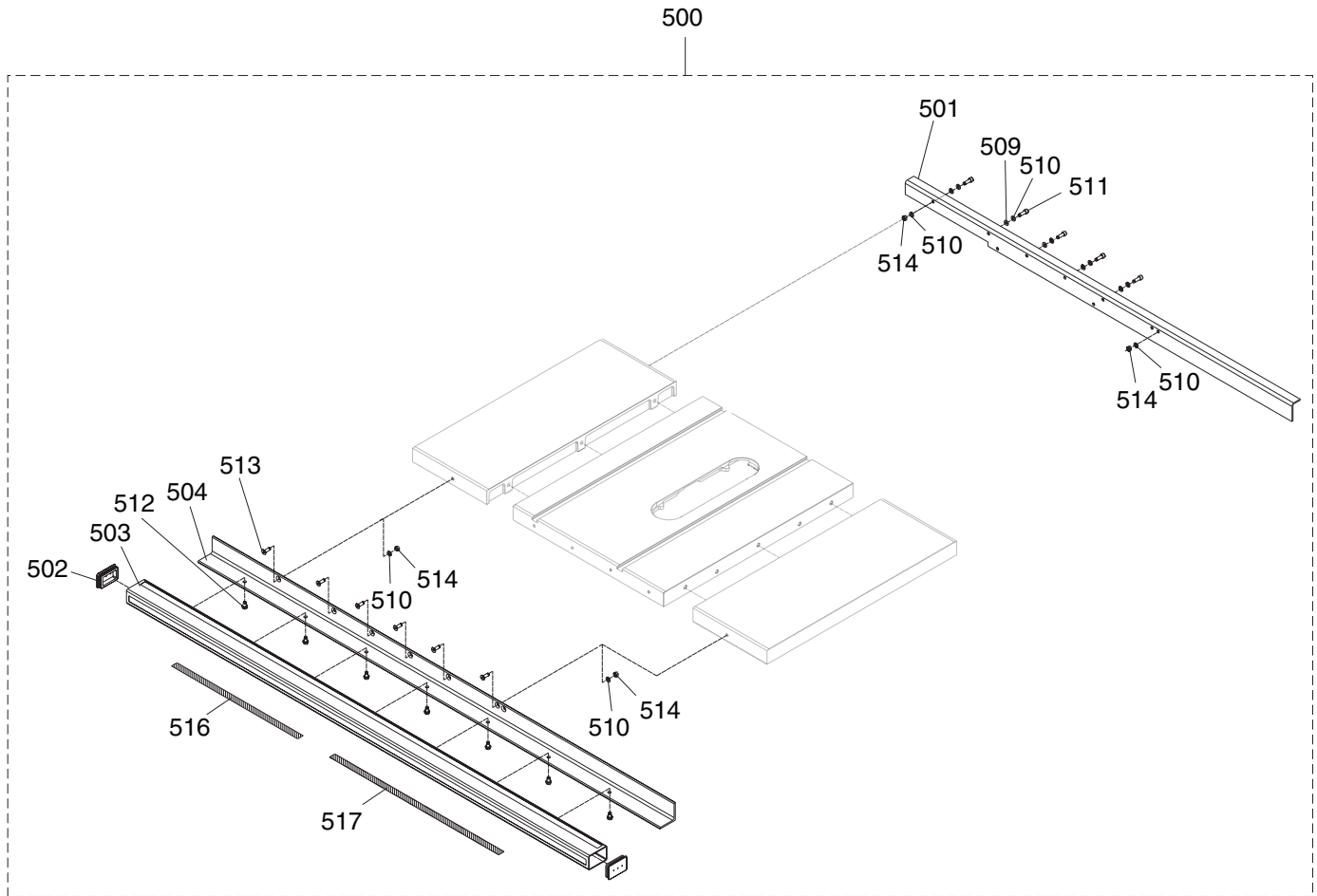

REF	PART #	DESCRIPTION
500	P0696X500	RAIL ASSEMBLY
501	P0696X501	REAR RAIL
502	P0696X502	END CAP
503	P0696X503	FENCE TUBE
504	P0696X504	FRONT RAIL
509	PW01M	FLAT WASHER 8MM
510	PLW04M	LOCK WASHER 8MM

REF	PART #	DESCRIPTION
511	PCAP31M	CAP SCREW M8-1.25 X 25
512	PFB15M	FLANGE BOLT M8-1.25 X 12
513	PFH21M	FLAT HD SCR M8-1.25 X 25
514	PN03M	HEX NUT M8-1.25
516	P0605X1501	LEFT SCALE 18"
517	P0696X517	RIGHT SCALE 36"



Labels & Cosmetic Parts

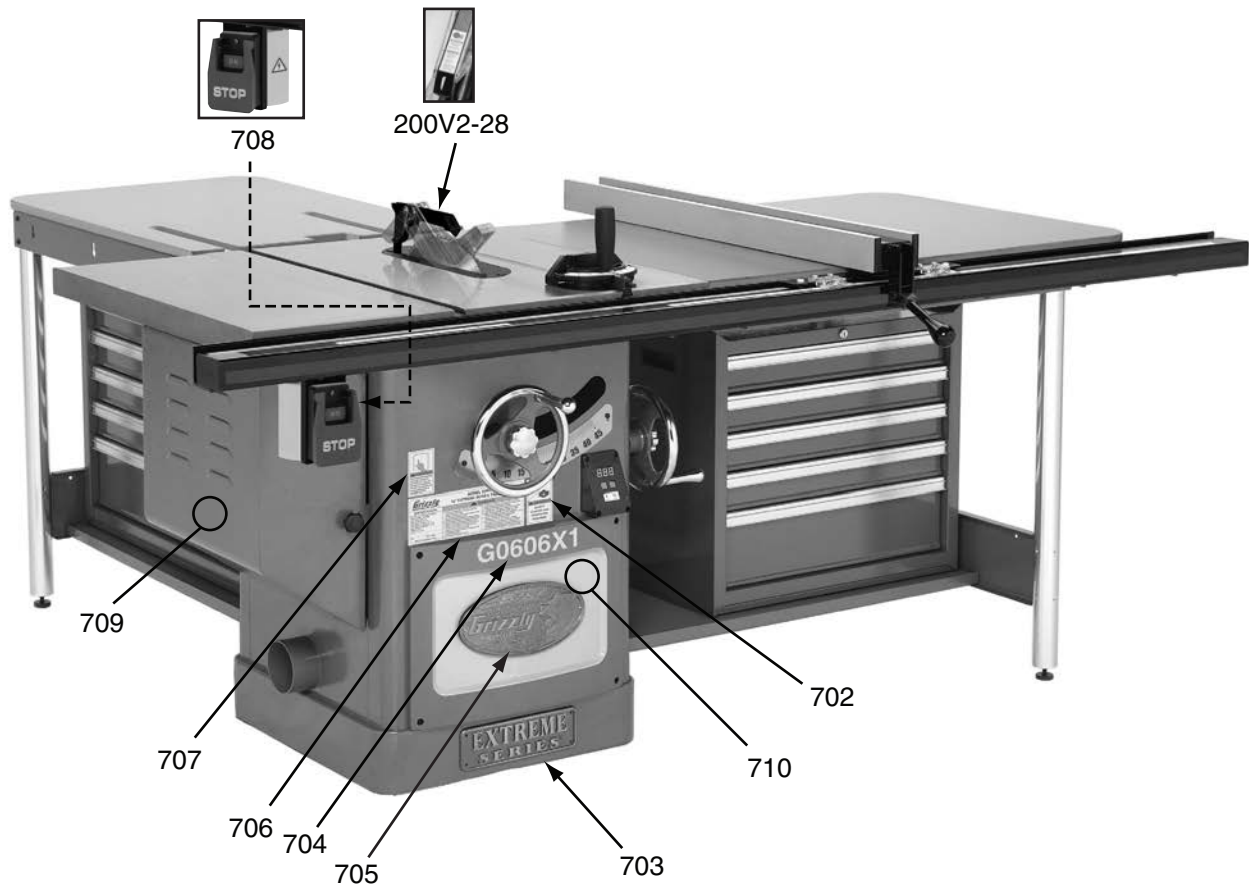

REF	PART #	DESCRIPTION
200V2-28	P0661002V2-28	AMPUTATION HAZ LABEL V2.01.10
702	PLABEL-57	GLASSES/RESPIRATOR 2W X 3.3H
703	H7942	EXTREME SERIES PLATE
704	P0605X1704	MODEL NUMBER LABEL
704	P0606X1704	MODEL # LABEL G0606X1
704	P0696X704	MODEL # LABEL G0696X
704	P0697X704	MODEL # LABEL G0697X
705	G8589	GRIZZLY NAMEPLATE-LARGE

REF	PART #	DESCRIPTION
706	P0605X1706	MACHINE ID LABEL G0605X1
706	P0606X1706	MACHINE ID LABEL G0606X1
706	P0696X706	MACHINE ID LABEL G0696X
706	P0697X706	MACHINE ID LABEL G0697X
707	PLABEL-12A	READ MANUAL-VERTICAL NS 7/05
708	PLABEL-14	ELECTRICITY LABEL
709	PPAINT-1	GRIZZLY GREEN PAINT
710	PPAINT-11	PUNITY TOUCH-UP PAINT

WARNING

Safety labels warn about machine hazards and ways to prevent injury. The owner of this machine **MUST** maintain the original location and readability of the labels on the machine. If any label is removed or becomes unreadable, **REPLACE** that label before using the machine again. Contact Grizzly at (800) 523-4777 or www.grizzly.com to order new labels.

