

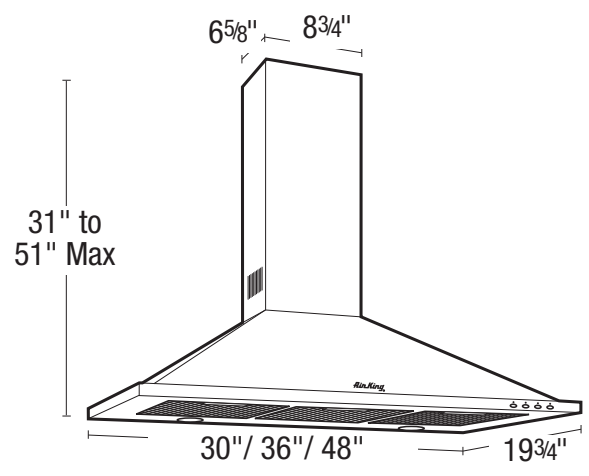

SPECIFICATIONS
GRANADA™
 WALL MOUNT RANGE HOODS

600 CFM/14.0 SONES @ 0.10" SP.

Barcelona®
Collection



- **Dimensions**
 Overall bottom projection - 19³/₄"
 Height (less chimney) - 11¹/₈"
 Available widths: 30", 36", 48"
- **Hood Body**
 Brushed stainless steel.
- **Motor**
 3 speed, permanently split capacitor motor. Rated 120 volts, 60 hz.
- **Lighting**
 Two - GU10 base, MR16, 50 watt halogen lights.
- **Ducting Options**
 Vertical ducting: 6" round duct adapter complete with polymeric back draft damper ensuring quiet operation.
 Ductless: Requires charcoal filter (not included).
- **Blower Wheel**
 Dual inlet, electronically balanced polymeric centrifugal blower wheel, 5³/₄" width 59 paddles.
- **Mounting**
 Ceiling mounted with included mounting bracket. Install 20" to 30" from cooking surface.
- **Filters**
 Grease Filter: Dishwasher safe, BCGF-01 (included).
 Charcoal Filter: BCCF-01 (not included).
- **Available Finishes**
 Stainless Steel.

EXPANDED PERFORMANCE

	Static Pressure (inches of w.g.)						Sones @ .1 SP	Fan Speed RPM	Power Watts	Amps
	0	0.1	0.25	0.5	0.75	1.0				
Air Flow - CFM	609	600	587	568	546	520	14.0	2560	542.0	2.8

PROJECT	ARCHITECT
LOCATION	ENGINEER
CONTRACTOR	SUBMITTED BY
	DATE

FAN NUMBER	MODEL NUMBER	CFM	IN W.C.	RPM	WATTS	AMPS	SONES	QTY	OPTIONAL EQUIPMENT & REMARKS



U.S.: 820 Lincoln Avenue
 West Chester, Pennsylvania 19380-4466
 Tel: (610) 692-7400 • 877-304-3785
 Fax: (610) 696-8048

Canada: 8 Edvac Drive
 Brampton, Ontario L6S 5P2
 Tel: (905) 456-2033 • 800-250-8767
 Fax: (905) 456-1015