

ID	Description	Technology	Status
SE4922-CA	Stone Effects 49x22in Capri VTop	Stone Effect	Approved for production
SER49-DN	Vtop SE Rect 49X22 Shark Tank Dot Com -Dune	Stone Effect	Approved for production
SERST49-WM	Vtop SE Rect 49X22 Shark Tank - Winter Mist	Stone Effect	Approved for production

Rev #	Approved by	Change
0	R. Rubio	Released

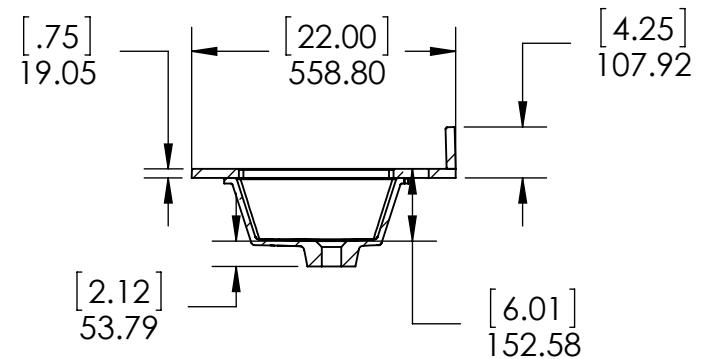
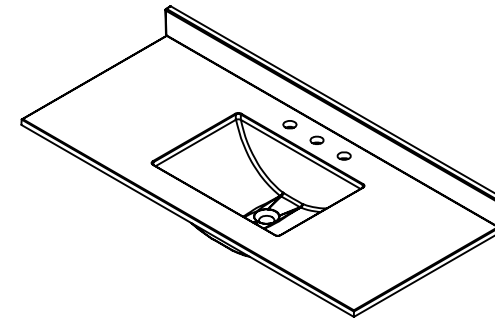
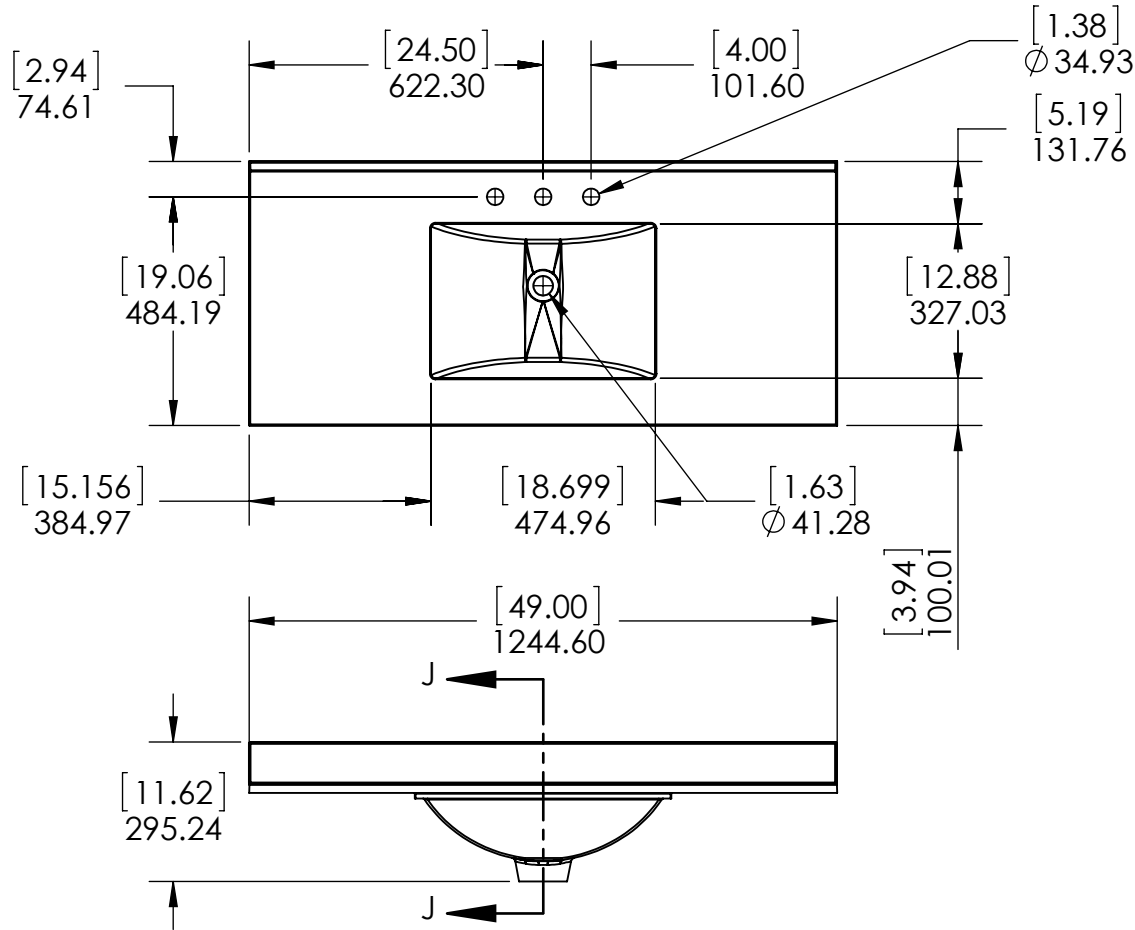

PROPRIETARY AND CONFIDENTIAL
 THE INFORMATION CONTAINED IN THIS DRAWING IS THE SOLE PROPERTY OF WOODCRAFTERS. ANY REPRODUCTION IN PART OR AS A WHOLE WITHOUT THE WRITTEN PERMISSION OF WOODCRAFTERS IS PROHIBITED.

UNLESS OTHERWISE SPECIFIED
 DIMENSIONS ARE IN MM. AND (INCHES)
 TOLERANCES ARE
 +0.125 [3.175] -0.125 [-3.175]
 SCALE:1:116

	NAME	DATE
DRAWN	R. Rubio	08/22/16
CHECKED	R. Rubio	08/22/16
ENG APPR.	R. Rubio	08/22/16
MFG APPR.	C. Leal	08/22/16

Wood Crafters

SIZE DWG. NO. **A** Vtop Stone Effect, Rect 49x22

SHEET 1 OF 1 REV: **0**

ITEM ID	DESCRIPTION
TB4821-CT	Thornbriar 48in x 21in D Vanity in Cement
TB4821-WH	Thornbriar 48in x 21in D Vanity in White

REV	ECO#	DESCRIPTION	REV'D BY DATE	CHK'D BY DATE	APR'V'D BY DATE
0		New Release	IASV 5/1/17	IASV 5/1/17	IASV 5/1/17

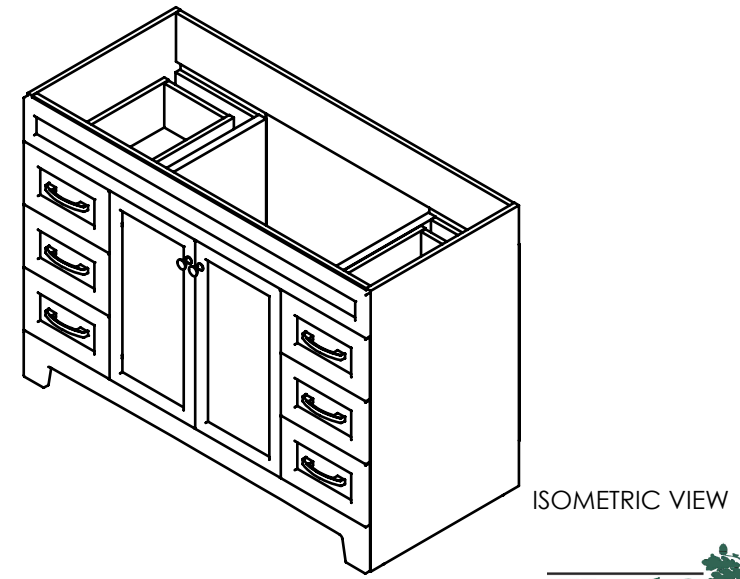
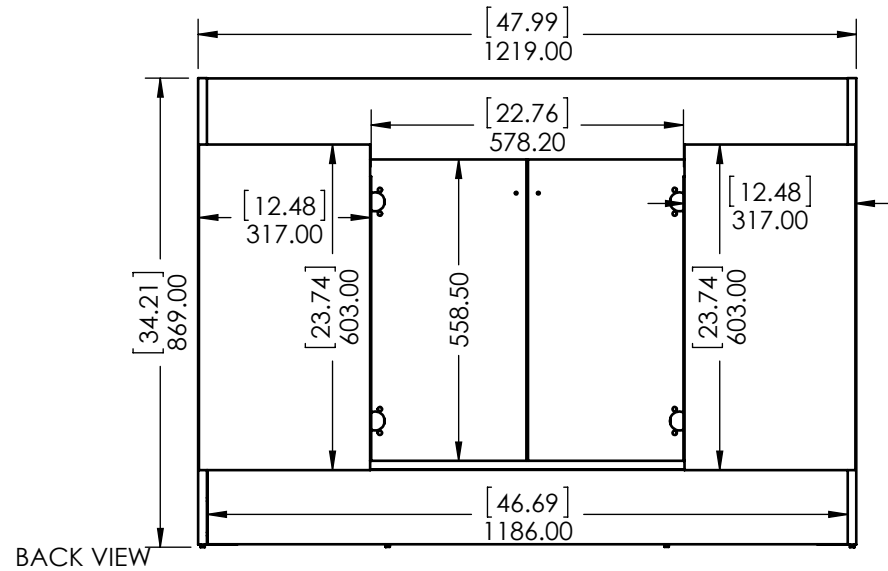
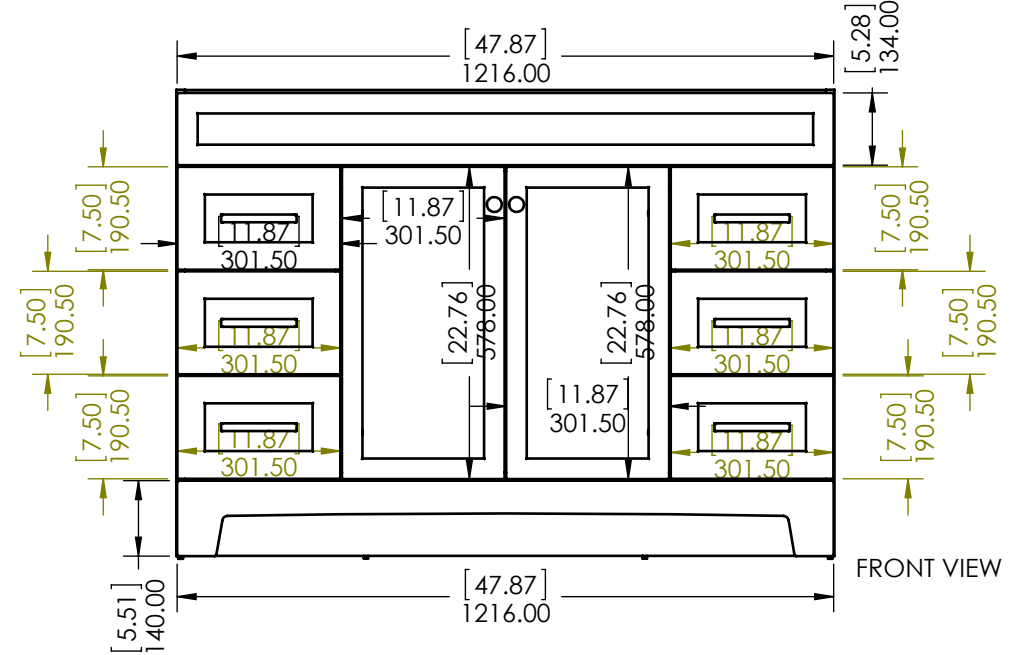
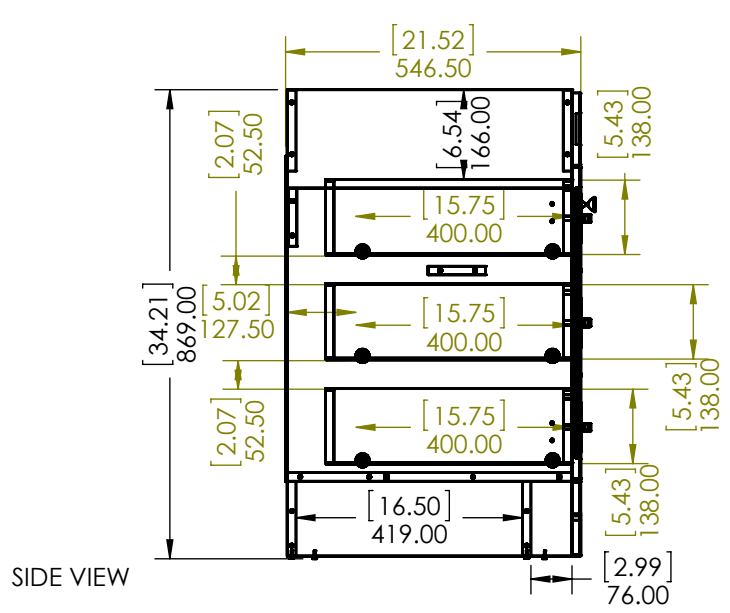

PROPRIETARY AND CONFIDENTIAL
 THE INFORMATION CONTAINED IN THIS DRAWING IS THE SOLE PROPERTY OF WOODCRAFTERS HOME PRODUCTS L.L.C. ANY REPRODUCTION IN PART OR AS A WHOLE WITHOUT THE WRITTEN PERMISSION OF WOODCRAFTERS HOME PRODUCTS L.L.C. IS PROHIBITED.

UNLESS OTHERWISE SPECIFIED
 DIMENSIONS ARE IN mm and [inches]
 AND TOLERANCES ARE +/- 1.0 [0.04]

DRAWN BY:	IASV	5/1/17
CHECKED BY:	IASV	5/1/17
APPROVED BY:	IASV	5/1/17
DO NOT SCALE DRAWING	SCALE: 1:10	SIZE: A

TITLE:	THORNBRIAR 48" ASSEMBLY		
PART NO:	PAGE	1 OF 1	REV: 0