

TAYAMA®

Rice Cooker with Steamer Attachment



Model: RC-3

Tayama Appliance USA Inc.
www.tayama-usa.com

Instruction Manual

Parts & Contents

Before using your Electric Rice Cooker for the first time, you should become familiar with all of the parts. Read all instructions and safeguards carefully before operating the unit.

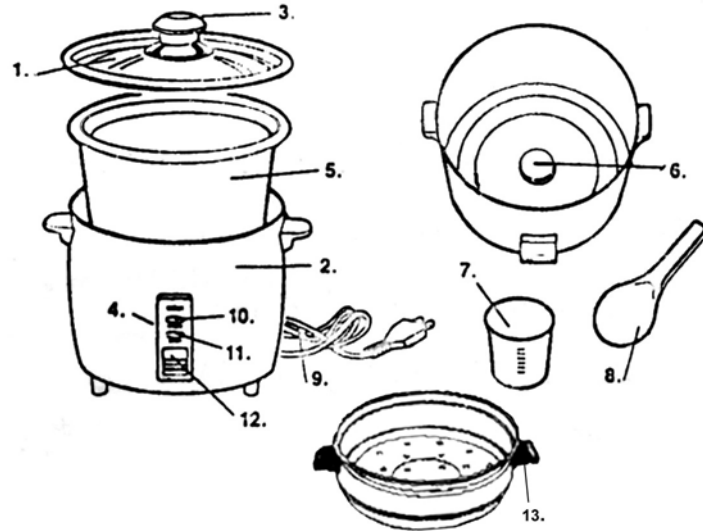

- | | | |
|--------------------------|------------------|------------------|
| 1) Lid | 5) Inner Pot | 9) Cord |
| 2) Heating Body | 6) Heating Plate | 10) "Warm" light |
| 3) Handle | 7) Measuring Cup | 11) "Cook" light |
| 4) Rice Cooking Switches | 8) Ladle | 12) Switch |
| | | 13) Steamer |

CAUTION:

To reduce the risk of electric shock, cook only in removable container.

Important Safeguards

When using electrical appliances, basic safety precautions should always be followed, including the following:

1. Read all instructions before operating.
2. Do not touch hot surfaces. Use handles or knobs.
3. To protect against electrical shock, do not immerse cord, plug or appliance itself in water or other liquids.
4. Close supervision is necessary when appliance is used near children.
5. Unplug from outlet when not in use and before cleaning. Allow to cool before putting on or taking off parts.
6. Do not operate any appliance with a damaged cord or plug or after the appliance malfunctions or has been damaged in any manner. Return the appliance to the nearest authorized service facility for examination, repair or adjustment.
7. The use of accessory attachments not recommended by the appliance manufacturer may cause injuries.
8. Do not use outdoors.
9. Do not let cord hang over edge of table or counter or touch hot surfaces.
10. Do not place on or near a hot gas or electric burner, or in a heated oven.
11. Always attach plug to appliance first, then plug cord into wall outlet. To disconnect, turn any control to OFF position, then remove plug from wall outlet.
12. Oversized foods or metal utensils must not be inserted in the appliance as they may cause a fire or risk of electrical shock.
13. A fire may occur if the appliance is covered or touching flammable material including curtains, draperies, walls and the like when in operation.
14. Do not clean with metal scouring pads. Pieces can break off the pad and touch electrical parts, involving a risk of electrical shock.
15. Extreme caution should be exercised when using containers constructed of other material other than metal or glass.
16. Do not store any materials other than manufacturers recommended accessories in this unit when not in use.
17. Do not place any of the following materials inside the unit: Paper, cardboard, plastic and the like.
18. This appliance is not intended for use by persons (including children) with reduced physical, sensory or mental capabilities, or lack of experience and knowledge, unless they have been given supervision or instruction concerning use of the appliance by a person responsible for their safety.
19. Children should be supervised to ensure that they do not play with the appliance.
20. If the supply cord is damaged, it must be replaced by a special cord or assembly available from the manufacture or its service agent.
21. If the supply cord is damaged, it must be replaced by the manufacturer, its service agent or similarly qualified persons in order to avoid a hazard.

SAVE THESE INSTRUCTIONS

THIS PRODUCT IS FOR HOUSEHOLD USE ONLY!

Before using your new Rice Cook

- 1) Only use this product with the correct AC voltage outlet. [For correct rated voltage, see box and label at the bottom of rice cooker unit.]
- 2) Be sure to unplug AC cord when pan is not in cooker, or when cooker is not being used. Remember the "Keep Warm" feature operates whenever the AC cord is plugged in.
- 3) Place the inner pot inside the cooker before operating. Turn the pot gently to the right and left.
- 4) If the switch button is difficult to depress to the "Cook" position, do not try to force it down. This difficulty usually occurs when inner pot is not fully inserted into the cooker or when the cooking cycle has just completed.
- 5) Place the lid on your inner pot while cooking. Keep the lid in place after serving to prevent your rice from drying out or discoloring.
- 6) Keep bottom of inner pot and surface of heater plate free of foreign matter to prevent operating malfunctions.

Check that the voltage on the rating plate of your appliance corresponds with your house electricity supply, which must be A.C. (Alternating Current).

If the socket outlet in your home is not suitable for the plug supplied with this appliance, the plug should be removed and fitted with the appropriate one.

WARNING: DO NOT USE A DAMAGED POWER CORD.

● **ATTENTION:** This appliance has a polarized plug (one blade is wider than the other). To reduce the risk of electric shock, this plug is intended to fit into polarized outlet only one way. If the plug does not fit fully into the outlet, reverse the plug. If it still does not fit, contact a qualified electrician. Do not attempt to modify the plug in the way.

WARNING: This appliance must be grounded.

Before using your cooker for the first time, wash and dry the bowl, steamer tray, lid and spatula in warm, soapy water. Afterwards dry thoroughly.

Maintenance Procedures

- 1) Remove inner pot and lid and wash them in hot soapy water, taking care to rinse completely, then dry with a soft cloth.
- 2) Clean outside of cooker with a clean damp cloth. Never clean any part of the cooker with abrasive cleaner. Use a damp cloth or sponge with water and mild dish detergent. Do not submerge any part of cooker in water. Wash only inner pot and lid.
- 3) To clean the heating plate and thermo-control plate, use steel wool to polish or remove any residue. Then wipe with a damp cloth. Allow to dry completely before re-using. You must keep the heating plate and thermo-control plate free from any foreign objects, otherwise the cooker will not operate properly.
- 4) Improper cleaning of cooker may cause unpleasant odors.
- 5) Any residue of vinegar or salt may cause pan to corrode.

How to Use

Always use the measuring cup provided in the package to measure and add rice to the inner pot.

COOKING RICE:

With measuring cup, add amount of water to the rice inside the inner pot according to the following estimated measurements provided below.

Cups of Uncooked Rice

15 Cups
14 Cups
12 Cups
10 Cups
8 Cups
6 Cups
4 Cups
2 Cups

Water added to line on pot

15 - 15 ½ Cups
14 - 14 ½ Cups
12 - 12 ½ Cups
11 - 11 ½ Cups
9 - 9 ½ Cups
7 - 7 ½ Cups
5 - 5 ½ Cups
3 - 3 ½ Cups

- 1) Set inner pot in cooker. Place rice and water in inner pot. Turn pan gently to right and left. Close lid securely.
- 2) Plug in power cord. Do not plug in until ready to cook. Otherwise rice may be spoiled. If pot is not in cooker, cooking will not begin.
- 3) Press switch to "Cook", indicator switch will say cooking has started.
- 4) When rice is done, the switch will pop up. Let rice stand covered for 15 minutes to steam rice.
- 5) Unplug after use. Grasp by the plug, not the cord to release.

*TIPS:

- Fill pot with uncooked rice after washing, Fill with water to overlap the layer of rice by ½ " to 1", this will result in "perfectly" cooked rice.

- When cooking brown rice, periodically lift the lid to stir the rice along the bottom of the pot to prevent sticking.

STEAMING:

You can also use your rice cooker to steam a variety of foods such as vegetables, fish, and even potatoes.

- 1) Fill the steamer attachment with desired food for steaming.
- 2) Fill the rice cooker half way with room temperature water.
- 3) Set the steamer onto the rice cooker.
- 4) Cover with glass lid.
- 5) Press the switch to "Cook", indicator switch will say cooking has started.
- 6) Be careful when removing the lid for hot steam will rush out.

STEW:

Stewing in the rice cooker is quite similar to stewing in a slow cooker. Simply combine all the ingredients for your stew and place into the inner pot. Make sure when stewing that the water capacity should not be more than 70% of the volume of the inner pot.

Simply follow the instructions for cooking rice to stew with your deluxe rice cooker.