

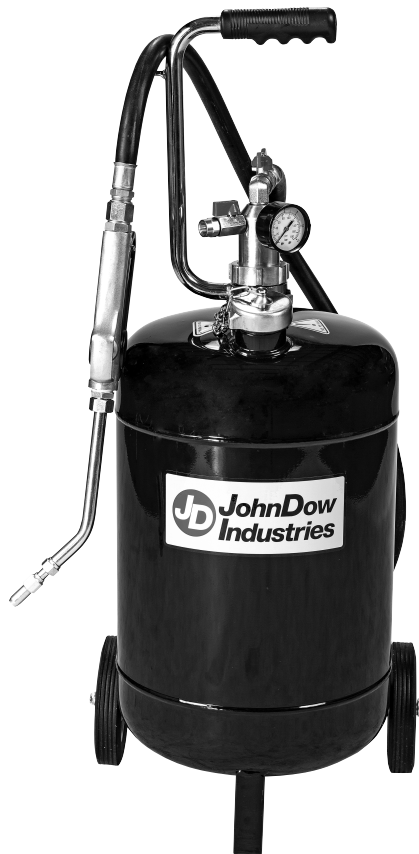

5-Gallon Fluid Dispenser

Model JDI-5DP
Owner's Manual



151 Snyder Ave.
Barberton, OH 44203

www.johndow.com
customerservice@johndow.com

REV 9/19/17

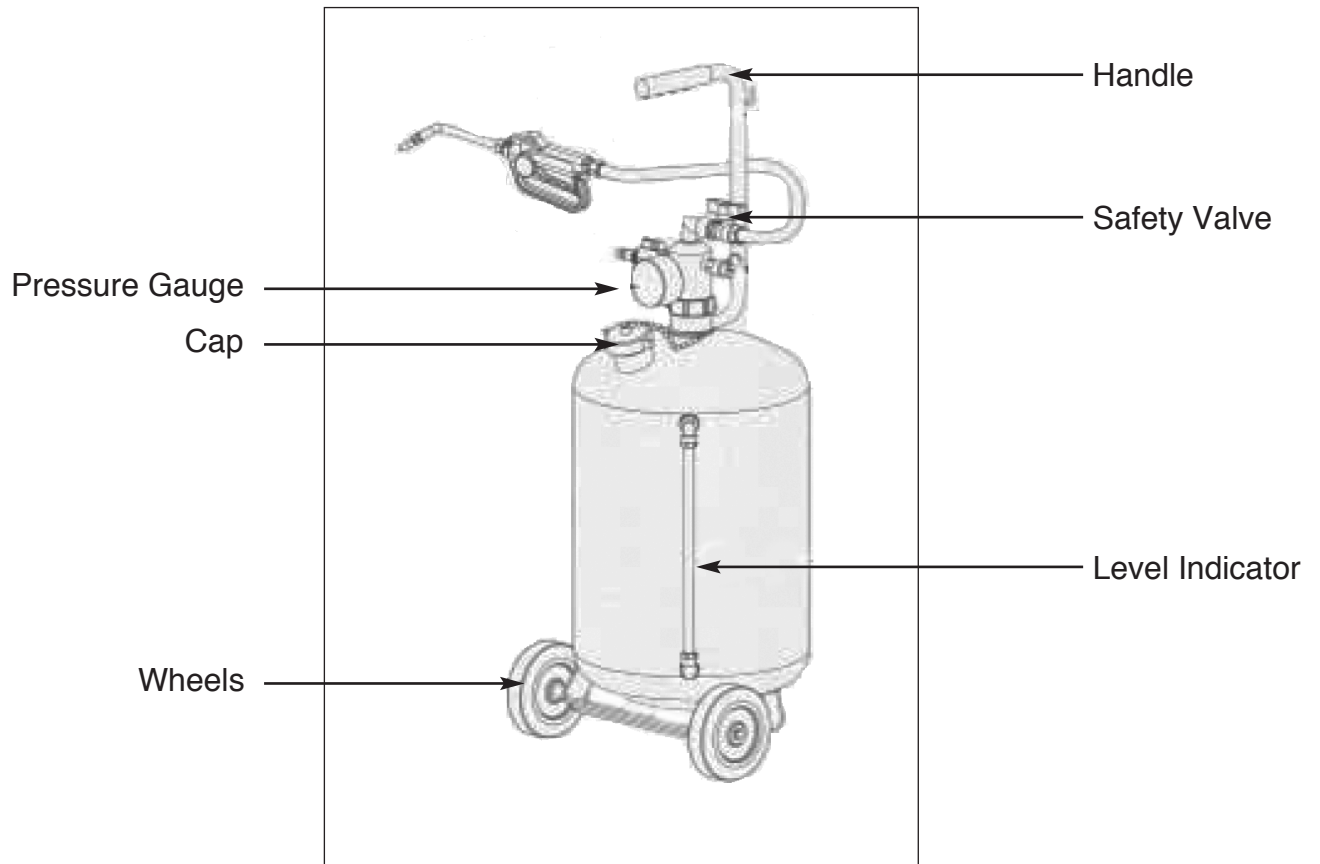

Operation:

1. Remove the cap A and fill the tank with oil no more than the maximum level shown on the level indicator B. (See Fig. 2)

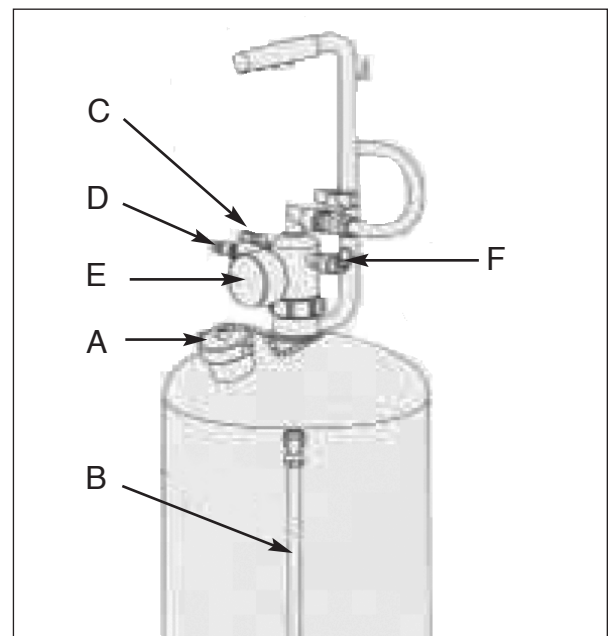

Fig. 2

Operation:

2. Replace the cap and tighten. (See Fig. 3)

3. Close air valve C. (See Fig. 3)

4. Open valve C to pressurize the tank 45 PSI (Maximum of 80 PSI). Monitor the pressure using the pressure gauge E. (See Fig. 3)

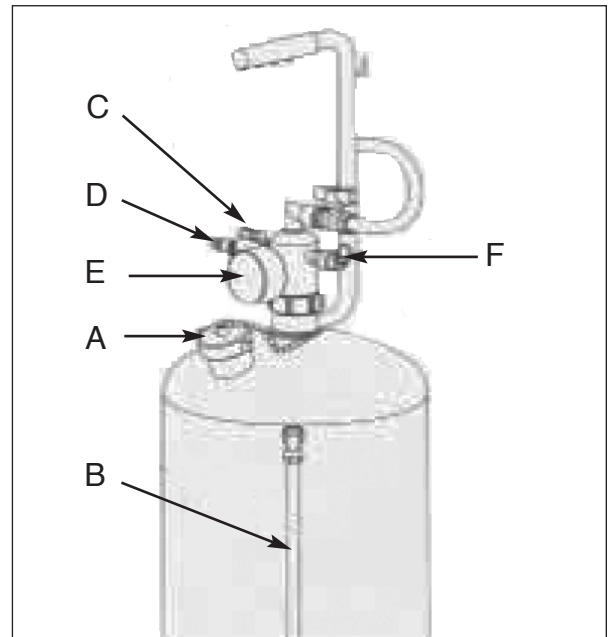

Fig. 3

NOTE: A safety valve F is installed to prevent over pressurization of the tank. The safety valve is calibrated at 90 PSI.

5. To dispense fluids, squeeze the handle on the fluid delivery gun G. (See Fig. 4)

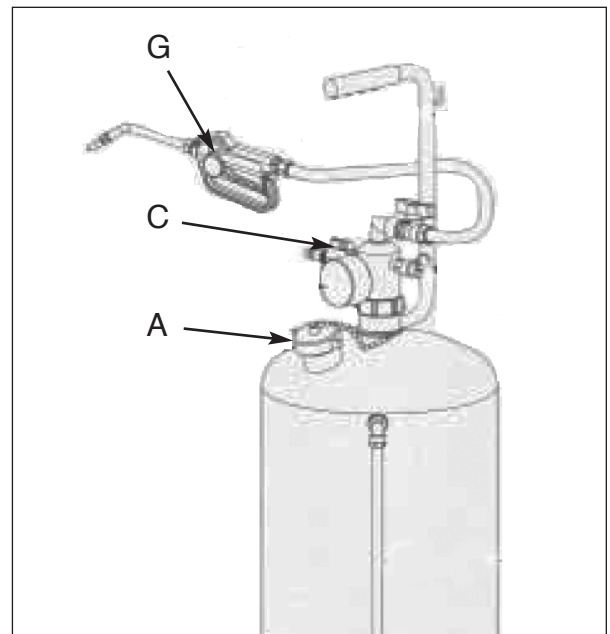

Fig. 4

Operation:

6. **IMPORTANT!** Before opening the cap A always discharge the tank of compressed air by opening valve C. (See Fig. 5)

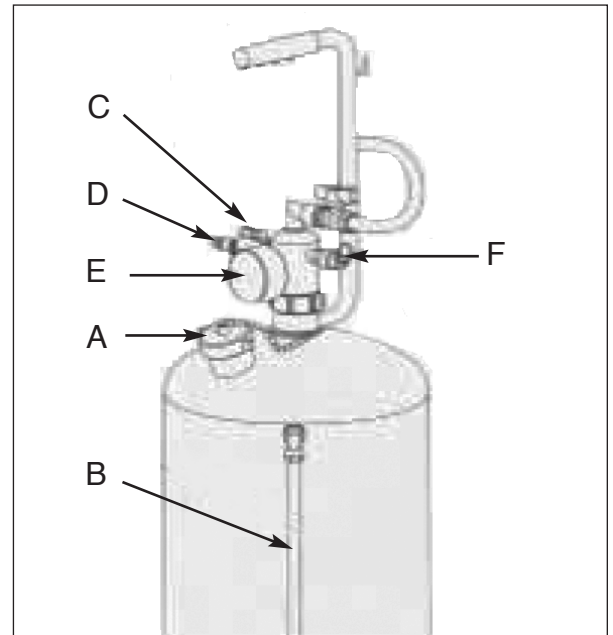

Fig. 5

WARNING! The JDI-5DP is designed to be used with gasoline or any other flammable liquids. Use of such material with these units could cause serious injury.

For Service Assistance
Phone Toll Free 1-800-433-0708
www.johndow.com