

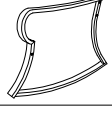

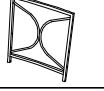

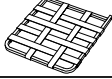

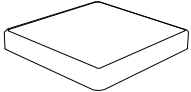
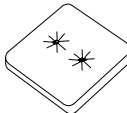

F01B031-R & F01B032-R & F01B033-R

3-Piece Rocking Bistro Set

Rocking Chair - DO THIS TWICE

Item no.	Reference Image	Description	Qty.
A		Left Arm Rest	1
B		Right Arm Rest	1
C		Seat Back	1
D		Seat Base	1
E		Bracket	2
F		Base Cushion	1
G		Back Cushion	1
H		M6 x 35 Socket Head Cap Screw	6
I		Washer	10
J		M6 x 32 Socket Head Cap Screw	4
K		Nut	4
L		Allen Key	1
M		Wrench	1

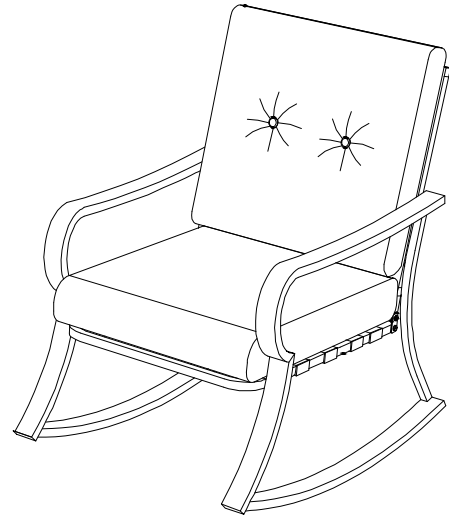

Tips:

Do not tighten screws fully until the item is well assembled.

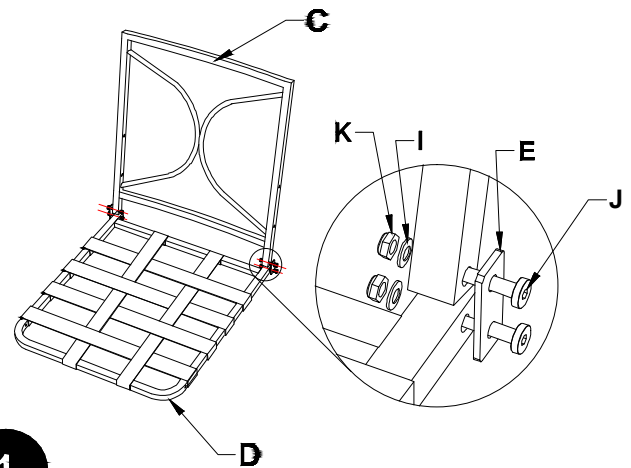

1

Secure the seat back (C) to the seat base (D) by fastening a bracket (E) using M6 x32 socket head cap screw (J) with a washer (I). Do this in four places.

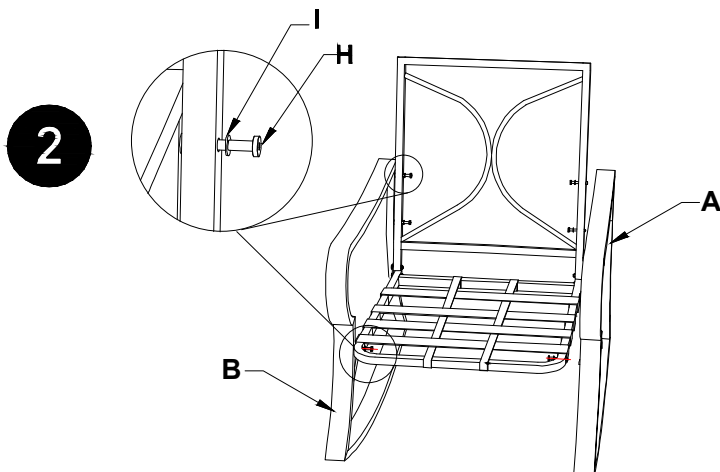

2

Secure the arm rests (A & B) to the seat back (C) and base (D) using M6 x 35 socket head cap screw (H) with a washer (I). Do this in six places.

F01B031-R & F01B032-R & F01B033-R**3-Piece Rocking Bistro Set****Rocking Chair - DO THIS TWICE****3**

Check assembly alignment and tighten all screws. Place the back (G) and base (F) cushions on the chair.

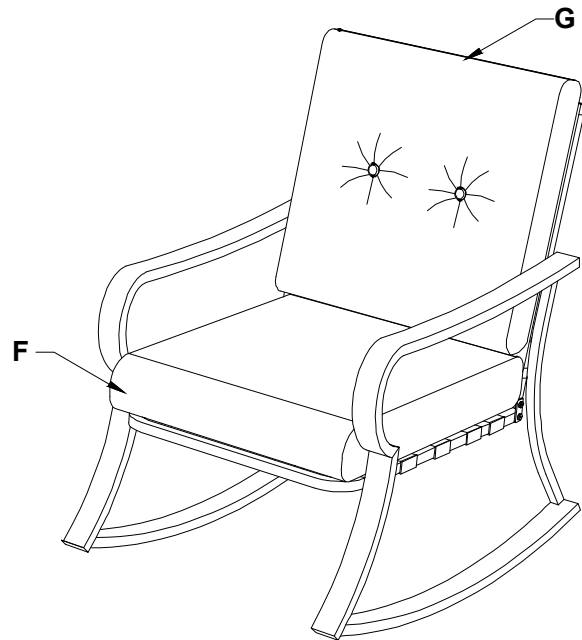





Tips: Do not tighten all screws fully before the item is well assembled.

F01B031-R & F01B032-R & F01B033-R

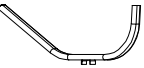
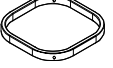
3-Piece Rocking Bistro Set

Coffee Table

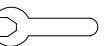
Item no.	Reference Image	Description	Qty.
N		Table Top	1
O		Table Leg	4
P		Leg Brace	1
Q		M6 x 38 Socket Head Cap Screw	4
I		Washer	8
K		Nut	4
L		Allen Key	1
M		Wrench	1

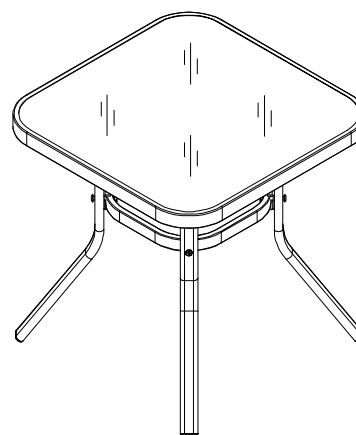

Tips:

Do not tighten screws fully until the item is well assembled.

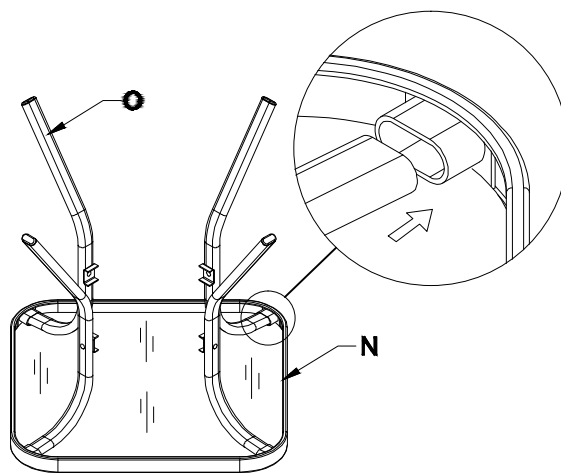

1

Flip table top (N) upside down. Attach table leg (O) to table top (N). Do this in four places.

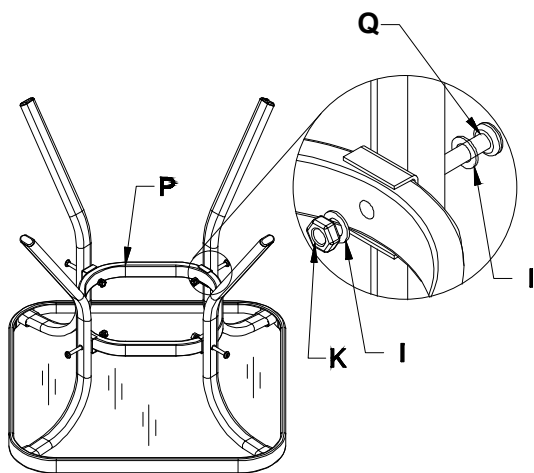

2

Attach the leg brace (P) to each table leg (O) using a M6 x 38 socket head cap screw (Q) with a washer (I) and a nut (K). Do this in four places.

3

Flip the assembly upright. Check assembly alignment and tighten all screws.

