

PRODUCT SPECIFICATIONS

Model: TC70065

Power supply voltage:	120V-60HZ	Working width:	11-IN
Tine Speed:	360 RPM	Working depth max:	8-IN
Power Consumption:	6.5 Amp		

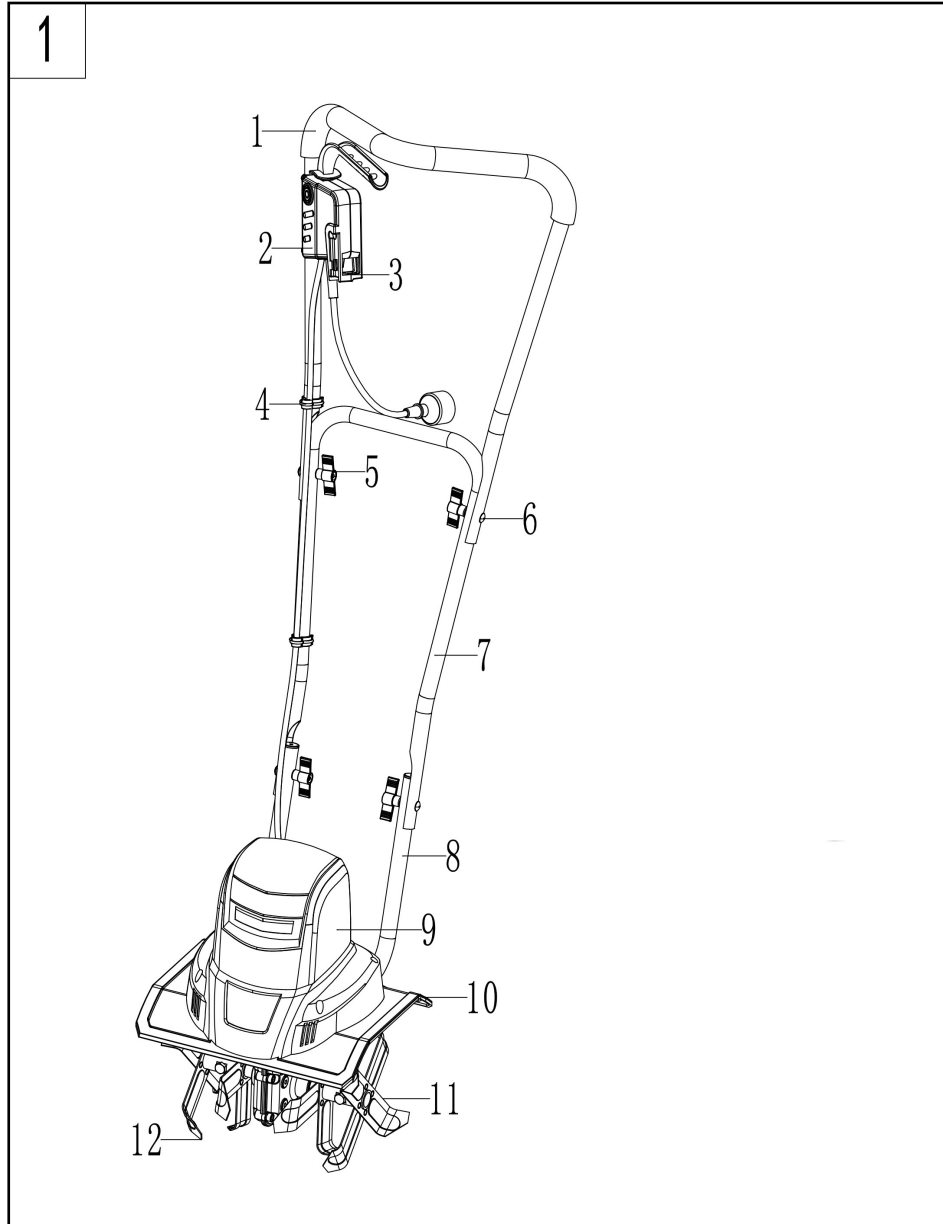

No.	Description	No.	Description
1	Upper handle section	7	Center handle section
2	Switch box and power cable assembly	8	Lower handle section
3	Cord retainer	9	Motor housing
4	Cable clip	10	Protective shield
5	Wing nut	11	Tine assembly 1
6	Carriage bolt M6 x 45	12	Tine assembly 2