

PRODUCT SPECIFICATION DRAWING

QUICKSTAND™ 30" X 30" (Water Heater & Equipment Support)

#40-S-30-A (assembled) and #40-S-30-U (unassembled)

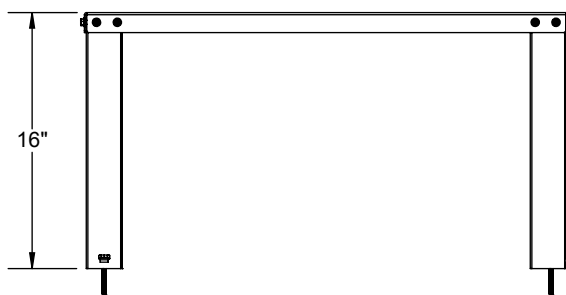
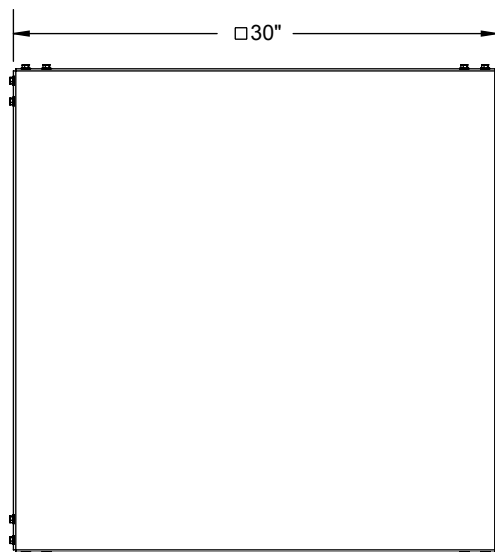
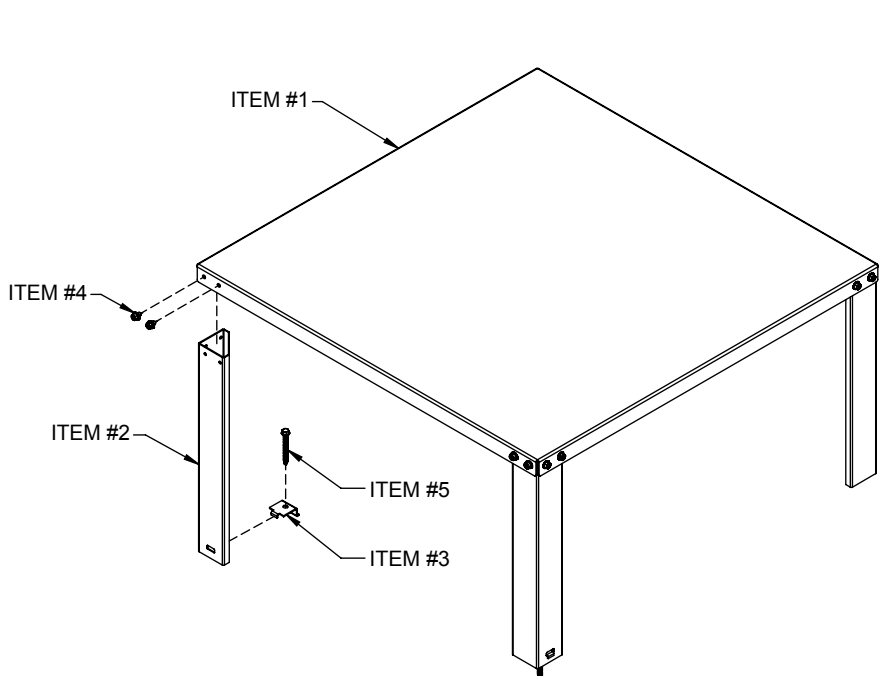

ALL DIMENSIONS IN INCHES

The QUICKSTAND™ #40-S-30- (A or U) stand safely elevates water heaters and other equipment above the floor (1,200 lbs rating).

Product Information:

- **Material:**
 - Item #1: Top, 12 gage CRS, galvanized
 - Item #2: Leg, 16 gage CRS, galvanized, 4 places
 - Item #3: Safety Clip, 14 gage CRS, galvanized, 2 places
 - Item #4: SMS, Phillips Hex Head Washer, w/Serrated Under Head, #1/4-14 X 1/2"L, 16 places
 - Item #5: Lag Bolt, #1/4-10 X 2-1/2"L, self-drilling, 2 places
(items #3 and #5 included with product)
- Engineered and lab tested to meet Uniform Plumbing Code (UPC) and International Plumbing Code (IPC) requirements, including elevation of water heater's ignition source 18" above the floor
- Holds up to 1,200 pounds capacity (up to 100 U.S. gallon tanks)
- QUICKSTAND™ weight 36 pounds without packaging
- Available in assembled and unassembled configurations

THIS INFORMATION IS PROPRIETARY TO HOLDRITE AND IS SUBJECT TO CHANGE WITHOUT NOTICE. IT MAY NOT BE REPRODUCED IN PART OR WHOLE WITHOUT WRITTEN AUTHORIZATION.



CONVERTING MAKESHIFT METHODS INTO ENGINEERED SOLUTIONSSM

800-321-0316 OR 760-744-6944 / FAX: 760-744-0507 / WWW.HOLDRITE.COM
spec_40-S-30_RevB

Product Submittal	
Job Name:	
Date:	
Part Number:	Qty:
Architect / Owner:	
Contractor:	
Notes:	