



# USER MANUAL

## INDUSTRIAL AIR COMPRESSOR

**SHOPTEK™**

**ST400, ST500, ST700, ST1100, ST1500**  
**4, 5, 7, 11 & 15 KW: 5, 7.5, 10, 15 & 20 HP**

---

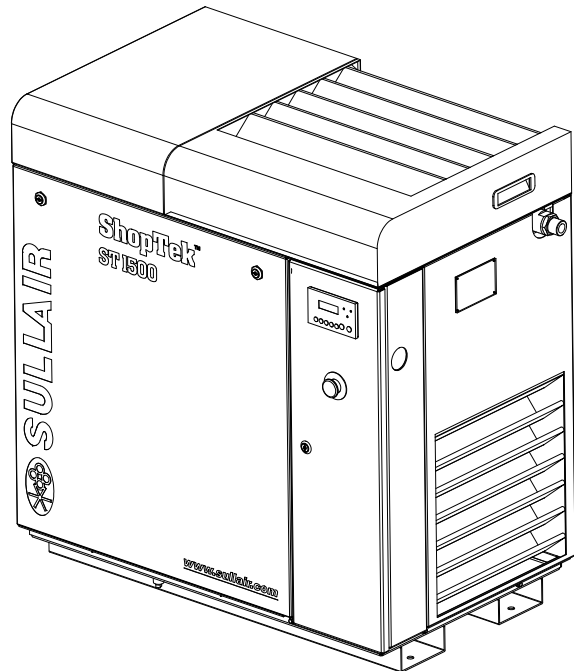
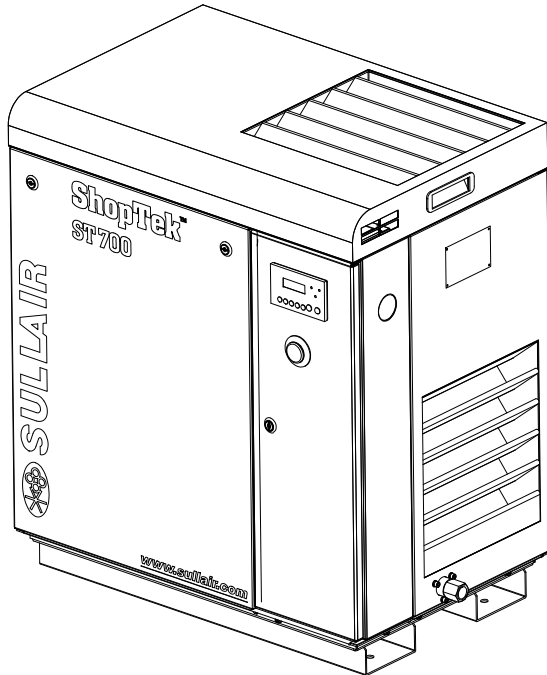

**PART NUMBER:**  
**02250180-090 R01**

**KEEP FOR  
FUTURE  
REFERENCE**

### WARRANTY NOTICE

**Failure to follow the instructions  
and procedures in this manual or,  
misuse of this equipment will  
VOID its warranty!**

**©SULLAIR CORPORATION**

The information in this manual is current  
as of its publication date, and applies to  
compressor **serial number:**

**Base Mount: C03-C20350**

**Tank Mount: 200811010000**

and all subsequent serial numbers.



## **AIR CARE SEMINAR TRAINING**

Sullair Air Care Seminars are courses that provide hands-on instruction for the proper operation, maintenance, and servicing of Sullair products. Individual seminars on Industrial compressors and compressor electrical systems are offered at regular intervals throughout the year at Sullair's corporate headquarters training facility located at Michigan City, Indiana.

Instruction includes training on the function and installation of Sullair service parts, troubleshooting common faults and malfunctions, and actual equipment operation. These seminars are recommended for maintenance, contractor maintenance, and service personnel.

For detailed course outlines, schedule, and cost information contact:

### **SULLAIR CUSTOMER CARE TRAINING DEPARTMENT**

1-888-SULLAIR or  
219-879-5451 (ext. 5623)  
[www.sullair.com](http://www.sullair.com)

- Or Write -

**Sullair Corporation**  
3700 E. Michigan Blvd.  
Michigan City, IN 46360  
Attn: Service Training Department.

**SECTION 1—SAFETY**

3	1.1	GENERAL
3	1.2	PERSONAL PROTECTIVE EQUIPMENT
3	1.3	PRESSURE RELEASE
4	1.4	FIRE AND EXPLOSION
4	1.5	MOVING PARTS
5	1.6	HOT SURFACES, SHARP EDGES AND SHARP CORNERS
5	1.7	TOXIC AND IRRITATING SUBSTANCES
6	1.8	ELECTRICAL SHOCK
6	1.9	LIFTING
7	1.10	ENTRAPMENT

**SECTION 2—DESCRIPTION**

9	2.1	INTRODUCTION
9	2.2	COMPRESSOR COMPONENT DESCRIPTION
14	2.3	COMPRESSOR COOLING AND LUBRICATION SYSTEM — FUNCTIONAL DESCRIPTION
14	2.4	COMPRESSOR DISCHARGE SYSTEM—FUNCTIONAL DESCRIPTION
14	2.5	CONTROL SYSTEM — FUNCTIONAL DESCRIPTION
17	2.6	AIR INLET SYSTEM, FUNCTIONAL DESCRIPTION
18	2.7	CONTROLLER/KEYPAD
18	2.8	LCD DISPLAY
19	2.9	LED LIGHTS

**SECTION 3—SPECIFICATIONS**

21	3.1	TABLE OF SPECIFICATIONS
22	3.2	COMPRESSOR SPECIFICATIONS
22	3.3	LUBRICATION GUIDE
22	3.4	APPLICATION GUIDE
23	3.5	LUBRICATION CHANGE RECOMMENDATIONS AND MAINTENANCE, FLUID FILTER AND SEPARATOR
36	3.6	TANK MOUNT AND DRYER OPTIONS

**SECTION 4—INSTALLATION**

49	4.1	COMPRESSOR MOUNTING - SUPPORT AND LOCATION
49	4.2	VENTILATION AND COOLING
51	4.3	SERVICE AIR PIPING
52	4.4	BELT CHECK
52	4.5	FLUID LEVEL CHECK
53	4.6	ELECTRICAL PREPARATION
53	4.7	MOTOR ROTATION DIRECTION CHECK

# TABLE OF CONTENTS

## SECTION 5—OPERATION

55	5.1	ROUTINE OPERATION
----	-----	-------------------

## SECTION 6—MAINTENANCE

57	6.1	GENERAL
57	6.2	MAINTENANCE AFTER INITIAL 50 HOURS OF OPERATION
58	6.3	MAINTENANCE EVERY 2000 HOURS
58	6.4	FLUID MAINTENANCE
58	6.5	FILTER MAINTENANCE
59	6.6	AIR FILTER MAINTENANCE
60	6.7	SEPARATOR MAINTENANCE
61	6.8	BELT MAINTENANCE
65	6.9	REPLACEMENT AND ALIGNMENT OF BELT PULLEYS
66	6.10	HOSE MAINTENANCE
66	6.11	TANK MOUNT PACKAGE MAINTENANCE
66	6.12	TROUBLESHOOTING – INTRODUCTION

# Section 1

# SAFETY

---

---

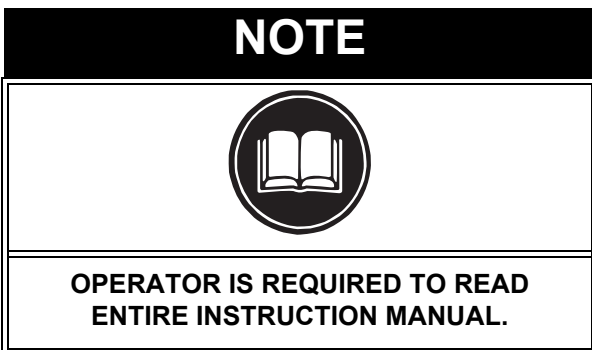

## 1.1 GENERAL

Sullair Corporation and its subsidiaries design and manufacture all of their products so they can be operated safely. However, the responsibility for safe operation rests with those who use and maintain these products. The following safety precautions are offered as a guide which, if conscientiously followed, will minimize the possibility of accidents throughout the useful life of this equipment.

The compressor should be operated only by those who have been trained and delegated to do so, and who have read and understood this Operator's Manual. Failure to follow the instructions, procedures and safety precautions in this manual may result in accidents and injuries. **NEVER** start the compressor unless it is safe to do so. **DO NOT** attempt to operate the compressor with a known unsafe condition. Tag the compressor and render it inoperative by disconnecting and locking out all power at source or otherwise disabling its prime mover so others who may not know of the unsafe condition cannot attempt to operate it until the condition is corrected.

Install, use and operate the compressor only in full compliance with all pertinent OSHA regulations and/or any applicable Federal, State, and Local codes, standards and regulations. **DO NOT** modify the compressor and/or controls in any way except with written factory approval.

While not specifically applicable to all types of compressors with all types of prime movers, most of

the precautionary statements contained herein are applicable to most compressors and the concepts behind these statements are generally applicable to all compressors.

## 1.2 PERSONAL PROTECTIVE EQUIPMENT

- A. Prior to installing or operating the compressor, owners, employers and users should become familiar with, and comply with, all applicable OSHA regulations and/or any applicable Federal, State and Local codes, standards, and regulations relative to personal protective equipment, such as eye and face protective equipment, respiratory protective equipment, equipment intended to protect the extremities, protective clothing, protective shields and barriers and electrical protective equipment, as well as noise exposure administrative and/or engineering controls and/or personal hearing protective equipment.

## 1.3 PRESSURE RELEASE

- A. Install an appropriate flow-limiting valve between the service air outlet and the shut-off (throttle) valve, either at the compressor or at any other point along the air line, when an air hose exceeding 1/2" (13mm) inside diameter is to be connected to the shut-off (throttle) valve, to reduce pressure in case of hose failure, per OSHA Standard 29 CFR 1926.302(b)(7) and/or any applicable Federal, State and Local codes, standards and regulations.
- B. When the hose is to be used to supply a manifold, install an additional appropriate flow-limiting valve between the manifold and each air hose exceeding 1/2" (13mm) inside diameter that is to be connected to the manifold to reduce pressure in case of hose failure.
- C. Provide an appropriate flow-limiting valve at the beginning of each additional 75 feet (23m) of hose in runs of air hose exceeding 1/2" (13mm)

inside diameter to reduce pressure in case of hose failure.

- D. Flow-limiting valves are listed by pipe size and flow-rated. Select appropriate valves accordingly, in accordance with their manufacturer's recommendations.
- E. **DO NOT** use air tools that are rated below the maximum rating of the compressor. Select air tools, air hoses, pipes, valves, filters and other fittings accordingly. **DO NOT** exceed manufacturer's rated safe operating pressures for these items.
- F. Secure all hose connections by wire, chain or other suitable retaining device to prevent tools or hose ends from being accidentally disconnected and expelled.
- G. Open fluid filler cap only when compressor is not running and is not pressurized. Shut down the compressor and bleed the receiver tank to zero internal pressure before removing the cap.
- H. Vent all internal pressure prior to opening any line, fitting, hose, valve, drain plug, connection or other component, such as filters and line oilers, and before attempting to refill optional air line anti-icer systems with antifreeze compound.
- I. Keep personnel out of line with and away from the discharge opening of hoses or tools or other points of compressed air discharge.
- J. **DO NOT** use air at pressures higher than 2.1 bar for cleaning purposes, and then only with effective chip guarding and personal protective equipment per OSHA Standard 29 CFR 1910.242 (b) and/or any applicable Federal, State, and Local codes, standards and regulations.
- K. **DO NOT** engage in horseplay with air hoses as death or serious injury may result.

## 1.4 FIRE AND EXPLOSION

- A. Clean up spills of lubricant or other combustible substances immediately, if such spills occur.
- B. Shut off the compressor and allow it to cool. Then keep sparks, flames and other sources of ignition away and **DO NOT** permit smoking in the vicinity when checking or adding lubricant or when refilling air line anti-icer systems with antifreeze compound.
- C. **DO NOT** permit fluids, including air line anti-icer system antifreeze compound or fluid film, to

accumulate on, under or around acoustical material, or on any external surfaces of the air compressor. Wipe down using an aqueous industrial cleaner or steam clean as required. If necessary, remove acoustical material, clean all surfaces and then replace acoustical material. Any acoustical material with a protective covering that has been torn or punctured should be replaced immediately to prevent accumulation of liquids or fluid film within the material. **DO NOT** use flammable solvents for cleaning purposes.

- D. Disconnect and lock out all power at source prior to attempting any repairs or cleaning of the compressor or of the inside of the enclosure, if any.
- E. Keep electrical wiring, including all terminals and pressure connectors in good condition. Replace any wiring that has cracked, cut, abraded or otherwise degraded insulation, or terminals that are worn, discolored or corroded. Keep all terminals and pressure connectors clean and tight.
- F. Keep grounded and/or conductive objects such as tools away from exposed live electrical parts such as terminals to avoid arcing which might serve as a source of ignition.
- G. Remove any acoustical material or other material that may be damaged by heat or that may support combustion and is in close proximity, prior to attempting weld repairs.
- H. Keep suitable fully charged Class BC or ABC fire extinguisher or extinguishers nearby when servicing and operating the compressor.
- I. Keep oily rags, trash, leaves, litter or other combustibles out of and away from the compressor.
- J. **DO NOT** operate the compressor without proper flow of cooling air or water or with inadequate flow of lubricant or with degraded lubricant.
- K. **DO NOT** attempt to operate the compressor in any classification of hazardous environment unless the compressor has been specially designed and manufactured for that duty.

## 1.5 MOVING PARTS

- A. Keep hands, arms and other parts of the body and clothing away from couplings, belts, pulleys, fans and other moving parts.
- B. **DO NOT** attempt to operate the compressor with the fan, coupling or other guards removed.

## SECTION 1

- C. Wear snug-fitting clothing and confine long hair when working around this compressor, especially when exposed to hot or moving parts.
- D. Keep access doors, if any, closed except when making repairs or adjustments.
- E. Make sure all personnel are out of and/or clear of the compressor prior to attempting to start or operate it.
- F. Disconnect and lock out all power at source and verify at the compressor that all circuits are de-energized to minimize the possibility of accidental start-up, or operation, prior to attempting repairs or adjustments. This is especially important when compressors are remotely controlled.
- G. Keep hands, feet, floors, controls and walking surfaces clean and free of fluid, water or other liquids to minimize the possibility of slips and falls.

### 1.6 HOT SURFACES, SHARP EDGES AND SHARP CORNERS

- A. Avoid bodily contact with hot fluid, hot coolant, hot surfaces and sharp edges and corners.
- B. Keep all parts of the body away from all points of air discharge.
- C. Wear personal protective equipment including gloves and head covering when working in, on or around the compressor.
- D. Keep a first aid kit handy. Seek medical assistance promptly in case of injury. **DO NOT** ignore small cuts and burns as they may lead to infection

### 1.7 TOXIC AND IRRITATING SUBSTANCES

- A. **DO NOT** use air from this compressor for respiration (breathing) except in full compliance with OSHA Standards 29 CFR 1910 and/or any applicable Federal, State or Local codes or regulations.

 **DANGER**



**Death or serious injury can result from inhaling compressed air without using proper safety equipment. See OSHA standards and/or any applicable Federal, State, and Local codes, standards and regulations on safety equipment.**

- B. **DO NOT** use air line anti-icer systems in air lines supplying respirators or other breathing air utilization equipment and **DO NOT** discharge air from these systems into unventilated or other confined areas.
- C. Operate the compressor only in open or adequately ventilated areas.
- D. Locate the compressor or provide a remote inlet so that it is not likely to ingest exhaust fumes or other toxic, noxious or corrosive fumes or substances.
- E. Coolants and lubricants used in this compressor are typical of the industry. Care should be taken to avoid accidental ingestion and/or skin contact. In the event of ingestion, seek medical treatment promptly. Wash with soap and water in the event of skin contact. Consult Material Safety Data Sheet for information pertaining to fluid of fill.
- F. Wear goggles or a full face shield when adding antifreeze compound to air line anti-icer systems.
- G. If air line anti-icer system antifreeze compound enters the eyes or if fumes irritate the eyes, they should be washed with large quantities of clean water for fifteen minutes. A physician, preferably an eye specialist, should be contacted immediately.
- H. **DO NOT** store air line anti-icer system antifreeze compound in confined areas.
- I. The antifreeze compound used in air line anti-freeze systems contains methanol and is toxic, harmful or fatal if swallowed. Avoid contact with the skin or eyes and avoid breathing the fumes. If

swallowed, induce vomiting by administering a tablespoon of salt, in each glass of clean, warm water until vomit is clear, then administer two teaspoons of baking soda in a glass of clean water. Have patient lay down and cover eyes to exclude light. Call a physician immediately.

## 1.8 ELECTRICAL SHOCK

- A. This compressor should be installed and maintained in full compliance with all applicable Federal, State and Local codes, standards and regulations, including those of the National Electrical Code, and also including those relative to equipment grounding conductors, and only by personnel that are trained, qualified and delegated to do so.
- B. Keep all parts of the body and any hand-held tools or other conductive objects away from exposed live parts of electrical system. Maintain dry footing, stand on insulating surfaces and **DO NOT** contact any other portion of the compressor when making adjustments or repairs to exposed live parts of the electrical system. Make all such adjustments or repairs with one hand only, so as to minimize the possibility of creating a current path through the heart.
- C. Attempt repairs in clean, dry and well lighted and ventilated areas only.
- D. **DO NOT** leave the compressor unattended with open electrical enclosures. If necessary to do so, then disconnect, lock out and tag all power at source so others will not inadvertently restore power.
- E. Disconnect, lock out, and tag all power at source prior to attempting repairs or adjustments to rotating machinery and prior to handling any ungrounded conductors.



**All field equipment must be tested for electrostatic fields prior to servicing or making contact with the machine using the following or equivalent test equipment:**

- **90-600 VAC: Volt detector such as Fluke Model 1AC-A**
- **600-7000 VAC: Voltage detector such as Fluke Networks Model C9970**

**It is the responsibility of each organization to provide/arrange training for all their associates expected to test for electrostatic fields.**

## 1.9 LIFTING

- A. If the compressor is provided with a lifting bail, then lift by the bail provided. If no bail is provided, then lift by sling. Compressors to be air-lifted by helicopter must not be supported by the lifting bail but by slings instead. In any event, lift and/or handle only in full compliance with OSHA standards 29 CFR 1910 subpart N and/or any applicable Federal, State, and Local codes, standards and regulations.
- B. Inspect points of attachment for cracked welds and for cracked, bent, corroded or otherwise degraded members and for loose bolts or nuts prior to lifting.
- C. Make sure entire lifting, rigging and supporting structure has been inspected, is in good condition and has a rated capacity of at least the weight of the compressor. If you are unsure of the weight, then weigh compressor before lifting.
- D. Make sure lifting hook has a functional safety latch or equivalent, and is fully engaged and latched on the bail or slings.
- E. Use guide ropes or equivalent to prevent twisting or swinging of the compressor once it has been lifted clear of the ground.
- F. **DO NOT** attempt to lift in high winds.
- G. Keep all personnel out from under and away from the compressor whenever it is suspended.
- H. Lift compressor no higher than necessary.



## SECTION 1

- I. Keep lift operator in constant attendance whenever compressor is suspended.
- J. Set compressor down only on a level surface capable of safely supporting at least its weight and its loading unit.
- K. When moving the compressor by forklift truck, utilize fork pockets if provided. Otherwise, utilize pallet if provided. If neither fork pockets or pallet are provided, then make sure compressor is secure and well balanced on forks before attempting to raise or transport it any significant distance.
- L. Make sure forklift truck forks are fully engaged and tipped back prior to lifting or transporting the compressor.
- M. Forklift no higher than necessary to clear obstacles at floor level and transport and corner at minimum practical speeds.
- N. Make sure pallet-mounted compressors are firmly bolted or otherwise secured to the pallet prior to attempting to forklift or transport them. **NEVER** attempt to forklift a compressor that is not secured to its pallet, as uneven floors or sudden stops may cause the compressor to tumble off, possibly causing serious injury or property damage in the process.

### 1.10 ENTRAPMENT

- A. If the compressor enclosure, if any, is large enough to hold a man and if it is necessary to enter it to perform service adjustments, inform other personnel before doing so, or else secure and tag the access door in the open position to avoid the possibility of others closing and possibly latching the door with personnel inside.
- B. Make sure all personnel are out of compressor before closing and latching enclosure doors.

**NOTES**

---

## Section 2

# DESCRIPTION

---

### 2.1 INTRODUCTION

The design of the Sullair ShopTek line of compressor units is a single stage, positive displacement, flooded rotary screw. A complete package includes the:

- Compressor unit
- Electric motor
- Starter
- Compressor inlet and discharge systems
- Compressor lubrication and cooling system
- Controller
- Aftercooler (ST1100 and ST1500 only)
- Heavy gauge steel mounting frame

#### CAUTION

**Use only one type of a recommended compressor lubricant. Adding a different one, or mixing lubricants can cause damage and/or malfunctions, and will void the compressor's warranty.**

New compressors are shipped from the factory fully charged with Sullube lubrication fluid. The SPECIFICATIONS *Section 3.3* and *Section 3.4* describe lubrication requirements and recommendations for each compressor package.

#### NOTE

**The compressor requires no internal inspections or maintenance actions. Opening the compressor's housing may void its warranty. (This does not apply to the shaft seal or inlet valve which are replaceable.)**

External piping, connectors, and the enclosure should be inspected and maintained in accordance with the procedures and recommendations in this manual.

### 2.2 COMPRESSOR COMPONENT DESCRIPTION

The ShopTek compressor (*Figure 2-1* and *Figure 2-2*) uses a fan to draw outside air into the enclosure, cooling the motors, the combined radiator fluid cooler, and air aftercooler. This hot air is then vented out of the top of the enclosure.

Fluid is injected into the compressor, and mixes directly with the air as the rotors turn which compresses the air. The fluid flow has three basic functions:

1. As a coolant, it controls the air temperature rise normally associated with the heat of compression.
2. Seals the clearance paths between the rotors and the stator, and also between the two rotors.
3. Provides a lubricating film between the rotors allowing one rotor to directly drive the other, which is an idler, and also lubricates the bearings.

After the air/fluid mixture is discharged from the compressor unit, the fluid is separated from the air. At this time, the air flows through an aftercooler and separator, and then to the service line while the fluid is cooled and filtered in preparation for reinjection.

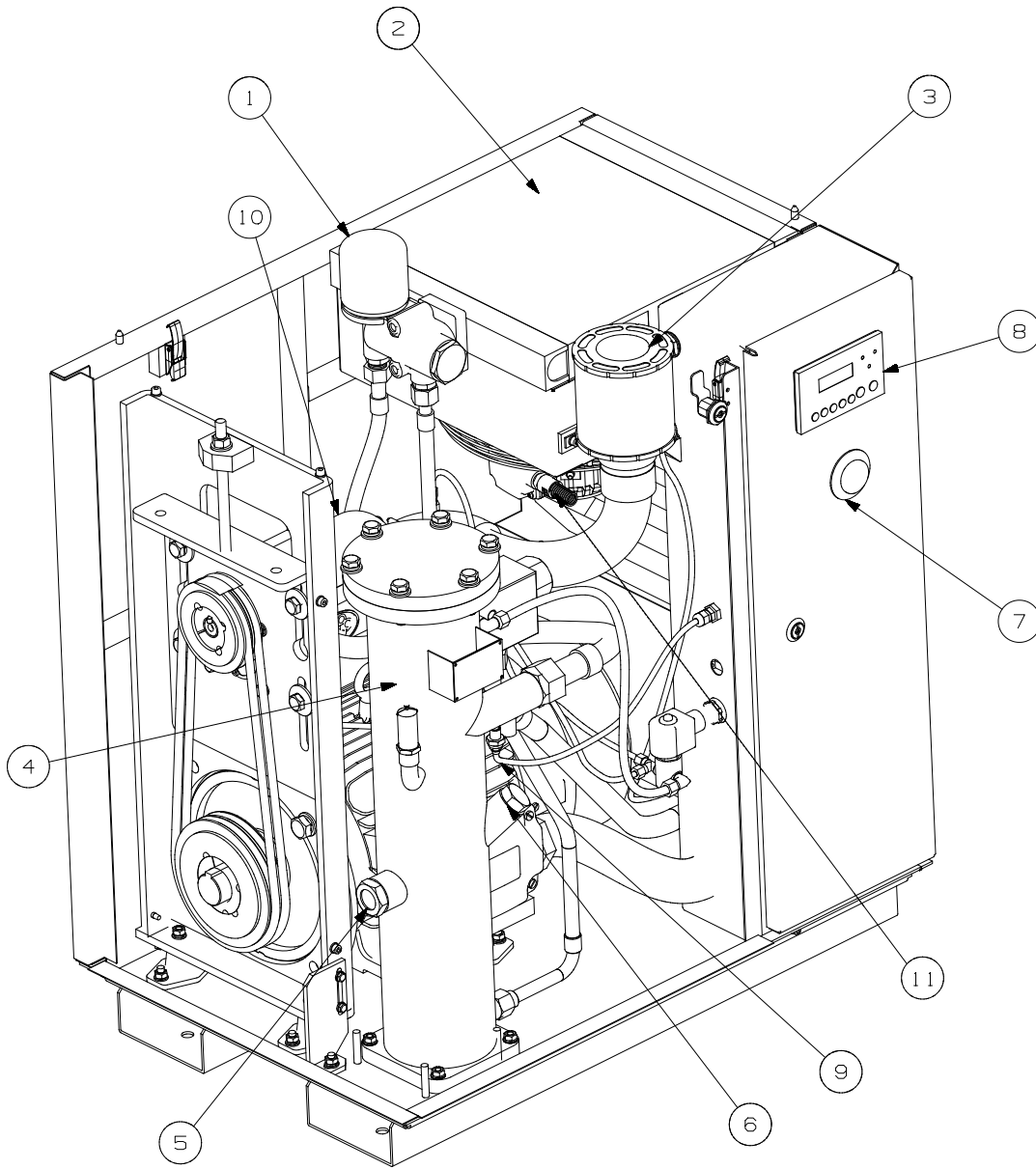

**Figure 2-1: Main Components, ST400, ST500, ST 700, 5 -10 HP**

1. Fluid Filter	7. E-Stop Button
2. Fluid Cooler	8. Controller
3. Air Inlet Filter	9. Main Motor
4. Separator Tube	10. Compressor Unit
5. Fluid Fill Sight Glass	11. Cooler Fan Motor
6. Fluid Fill	

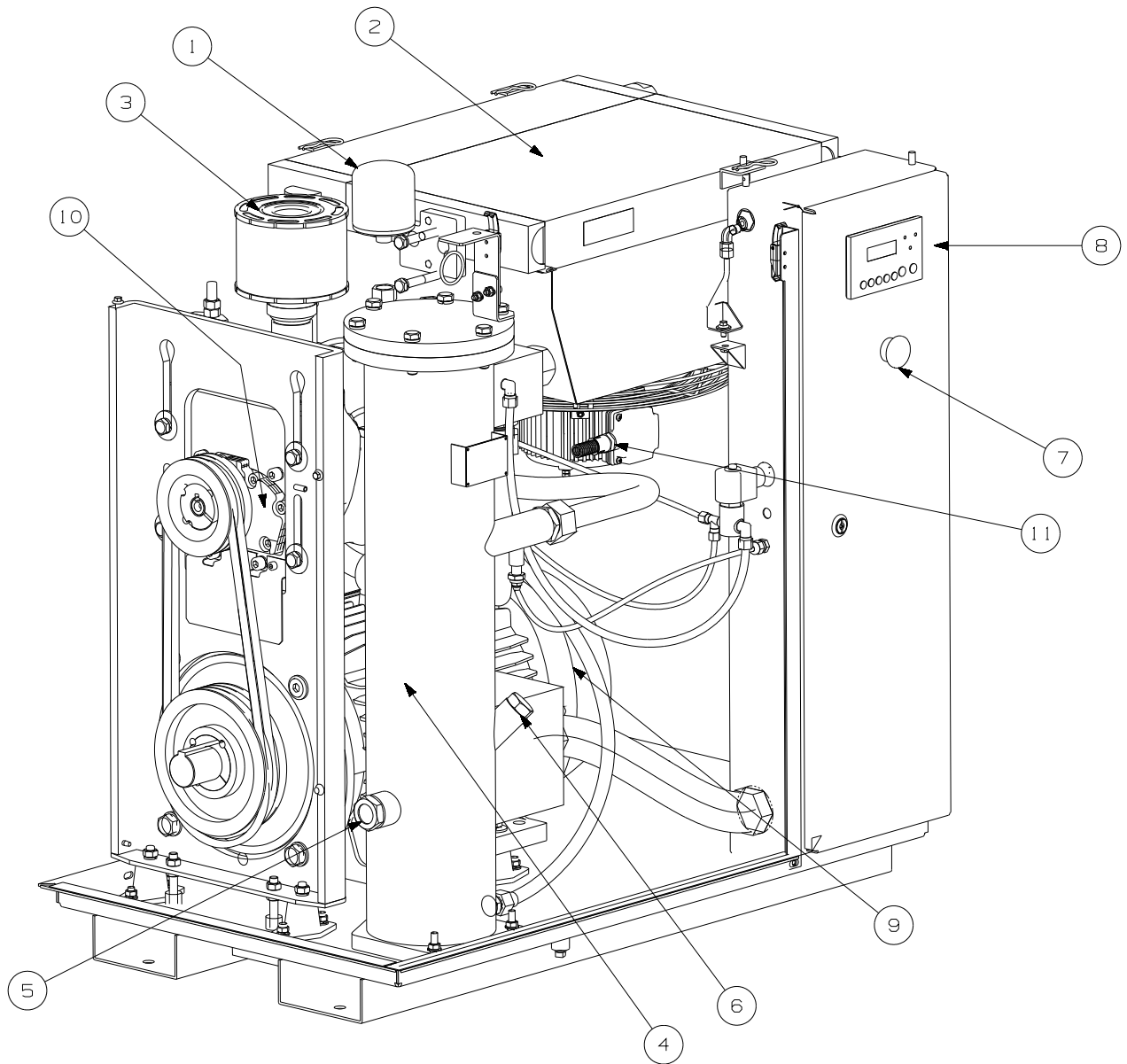

**Figure 2-2: Main Components, ST1100, ST1500, 15-20 HP**

1. Fluid Filter	7. E-Stop Button
2. Aftercooler/Fluid Cooler	8. Controller
3. Air Inlet Filter	9. Main Motor
4. Separator Tube	10. Compressor Unit
5. Fluid Fill Sight Glass	11. Cooler Fan Motor
6. Fluid Fill	

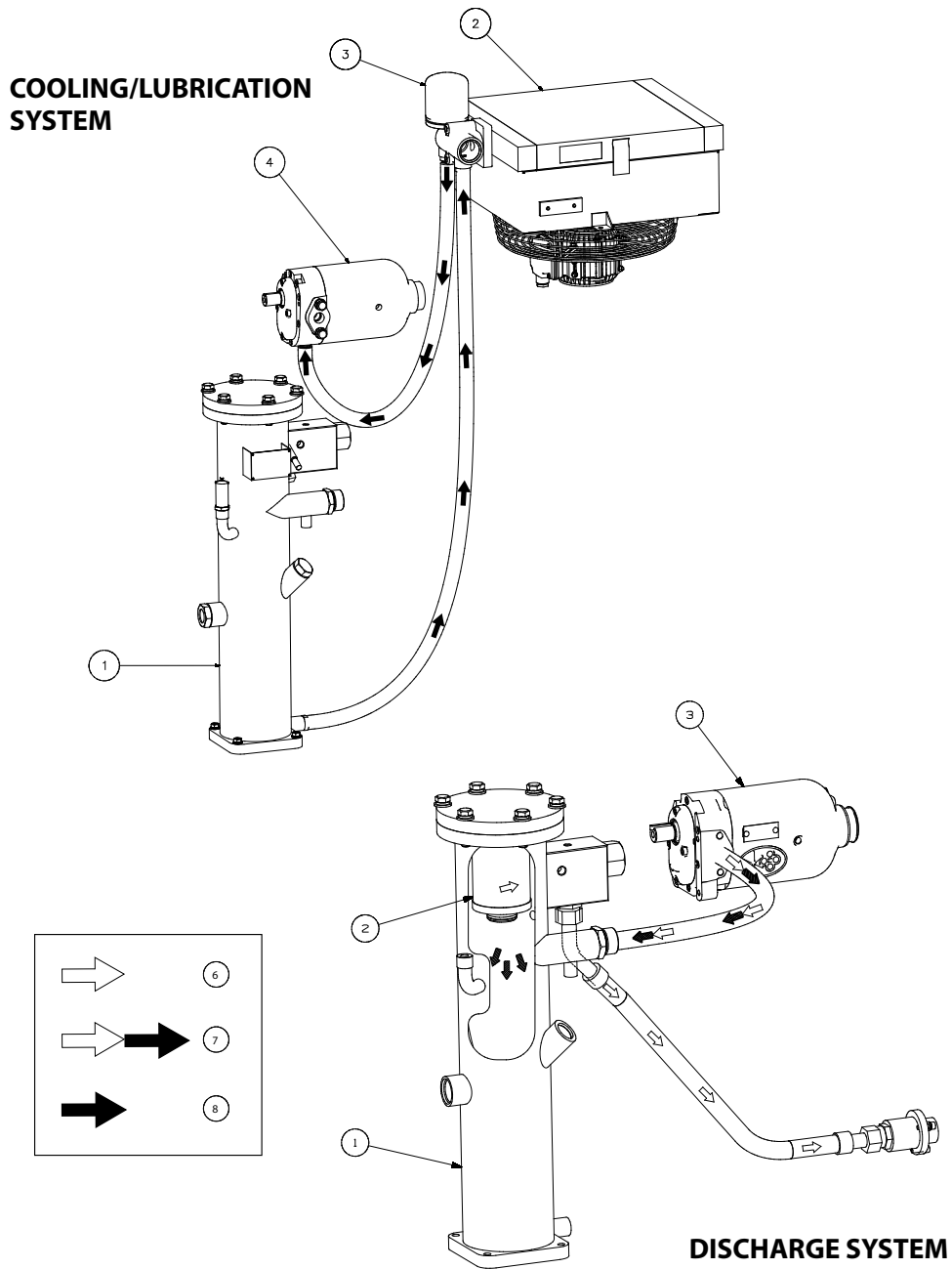

Figure 2-3: Cooling/Lubrication and Discharge System ST400, ST500 and ST700 5-10 HP

1. Separator Tube	5. Separator Element
2. Cooler	6. Air
3. Fluid Filter	7. Air/Fluid Mix
4. Compressor Unit	8. Fluid

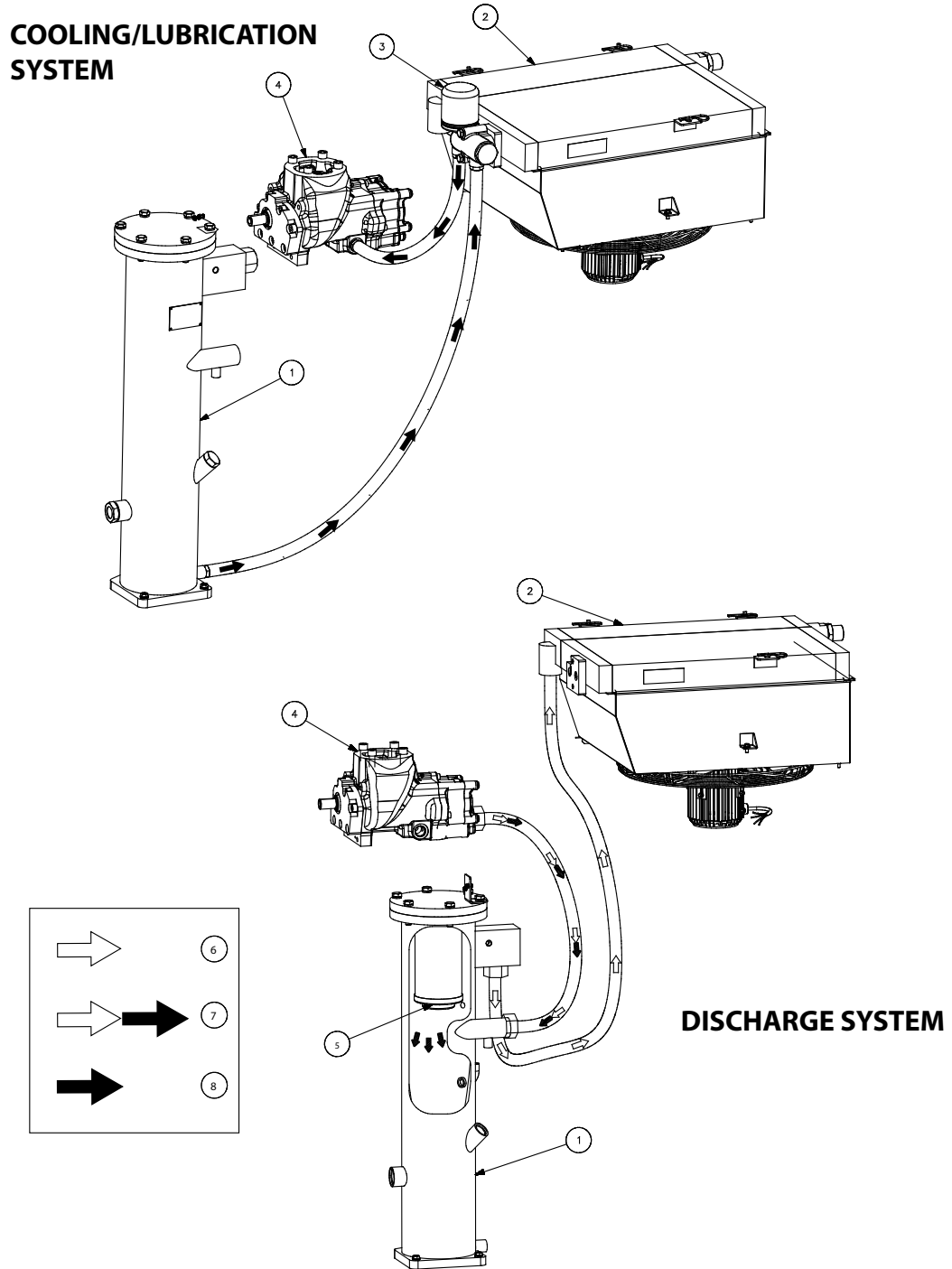

Figure 2-4: Cooling/Lubrication and Discharge System ST1100 and ST1500 15 & 20 HP

1. Separator Tube	5. Separator Element
2. Cooler	6. Air
3. Fluid Filter	7. Air/Fluid Mix
4. Compressor Unit	8. Fluid

### 2.3 COMPRESSOR COOLING AND LUBRICATION SYSTEM — FUNCTIONAL DESCRIPTION

Refer to *Figure 2-3* and *Figure 2-4*. The **cooling and lubrication system** consists of a **fan, fan motor, aftercooler (ST1100/ST1500 15-20HP only) /fluid cooler, full flow fluid filter, thermal valve, interconnecting hoses and separator tube.**

The pressure in the separator tube starts the fluid flow by forcing the fluid from the high pressure area of the tube to an area of lower pressure in the compressor unit. Fluid flows from the bottom of the separator/tube to the thermal valve that is fully open when the fluid temperature is below 185°F (85°C) [195°F (91°C) for pressures rated above 150 psig]. The fluid passes through the thermal valve, the fluid filter, and directly to the compressor where it lubricates, cools and seals the rotors, and the compression chamber.

As the discharge temperature rises above 185°F (85°C), due to the heat of compression, the thermal valve begins to adjust and a portion of the fluid then flows through the cooler. From the cooler the fluid flows to the fluid filter and on to the compressor. A portion of the fluid flow to the compressor is routed to the anti-friction bearings which support the compressor rotors.

The fluid filter must be replaced. Refer to *Section 3.5: Lubrication Change Recommendations and Maintenance, Fluid Filter And Separator* on page 23.

### 2.4 COMPRESSOR DISCHARGE SYSTEM—FUNCTIONAL DESCRIPTION

Refer to *Figure 2-3* and *Figure 2-4*. The compressor discharges the compressed air/fluid mixture into the separator/tube. The separator/tube has three basic functions:

1. It acts as a primary fluid separator.
2. Serves as the compressor fluid sump.
3. Houses the final fluid separator.

The compressed air/fluid mixture enters the separator/tube and flows through an internal baffle system that changes the flow’s direction and velocity, which causes most of the fluid to fall to the bottom of the separator tube. A small amount of fluid remaining in the compressed air collects on the surface of the

separator element as the air flows through the separator.

A return line (or scavenge tube) leads from the dry side of the separator tube to the medium pressure region. Scavenged fluid is returned by a pressure differential between the separator tube and compressor.

The separator system reduces the fluid carry-over to less than 2 ppm at nominal rated pressures.

The Controller will shut down the compressor if the discharge temperature reaches 235°F (113°C).

A minimum pressure/check valve located downstream from the separator maintains the separator tube pressure at 50 psig (3.4 bar) during load conditions. This pressure level is necessary for proper air/fluid separation and sufficient fluid circulation.

A terminal check valve is a sub-component of the minimum pressure/check valve that prevents compressed air in the service line from back-flowing into the separator tube on shutdown or when the compressor is operating in an unload condition. Also, a pressure relief valve on the compressor’s wet side opens if the separator tube pressure exceeds its rating.

WARNING

**Stop the compressor and relieve all internal pressure before removing caps, plugs, and/or other components when the compressor is running or pressurized.**

Add fluid to the separator tube through the capped fluid fill port. There is also a sight glass that enables the user to check the separator tube fluid level. See *Fluid Level Check* on page 52.

### 2.5 CONTROL SYSTEM — FUNCTIONAL DESCRIPTION

Refer to *Figure 2-5* and *Figure 2-6*. The **compressor control system** regulates its output to match the demand. This system consists of a **solenoid valve** and an **inlet valve** that control the compressor’s operational modes. The following descriptions of operational modes apply to a compressor whose operating range is 112 to 127 psig (7.7 to 8.8 bar)



Other pressure settings can be selected depending on compressor application or rating.

### START MODE - 0 TO 50 PSIG (0 TO 3.5 BAR)

There is no load on the compressor at startup, the solenoid valve is open and the inlet valve is closed. When the compressor (1) (START) pad is pressed, the separator tube pressure rises from 0 to 50 psig (0 - 3.4 bar). When it reaches its full operating speed (maximum rpm), the compressor switches to the Full Load Mode.

### FULL LOAD MODE - 50 TO 127 PSIG (3.4 TO 8.8 BAR)

When the compressed air pressure rises above 50 psig (3.4 bar), the minimum pressure valve opens allowing compressed air to flow into the service line. From this point on, the Controller continuously monitors the line air pressure. The solenoid valve remains closed in this mode. As long as the compressor is running at 127 psig (8.8 bar) or lower, the inlet valve is fully open.

### UNLOAD MODE - GREATER THAN 127 PSIG (8.8 BAR)

When there is no, or only a small demand, the

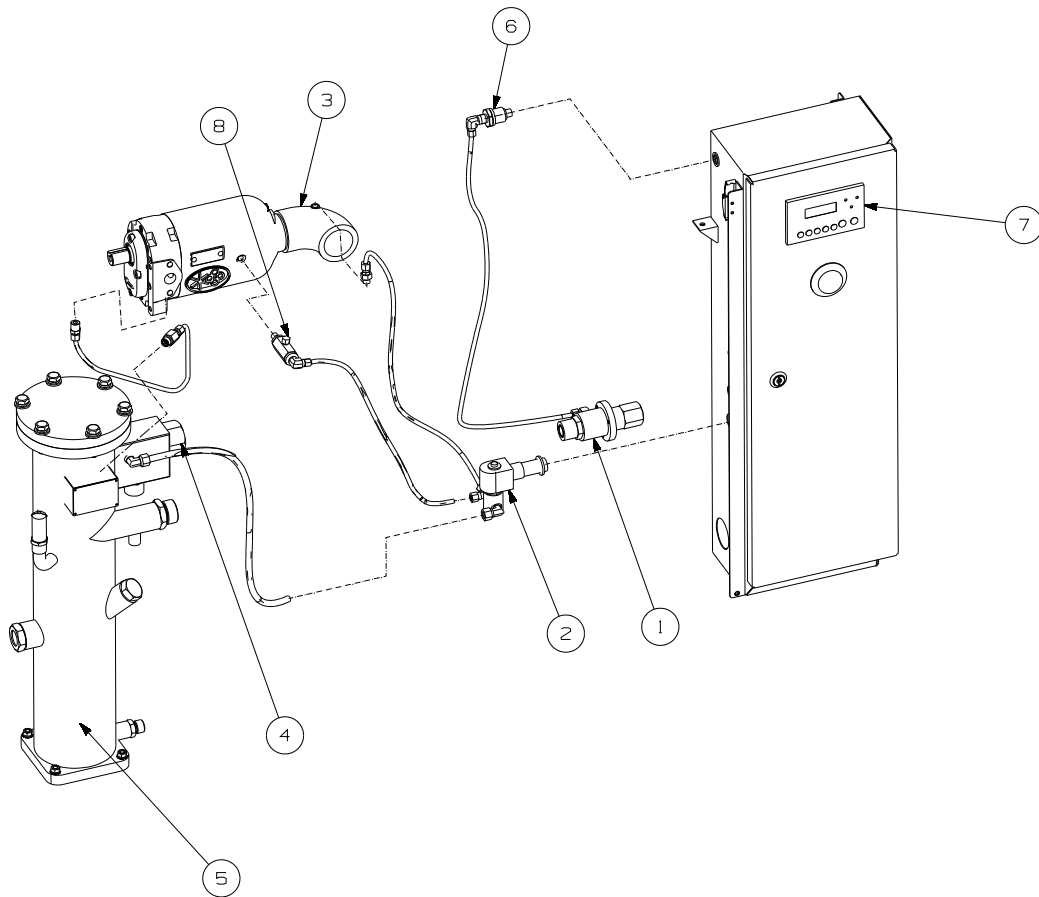
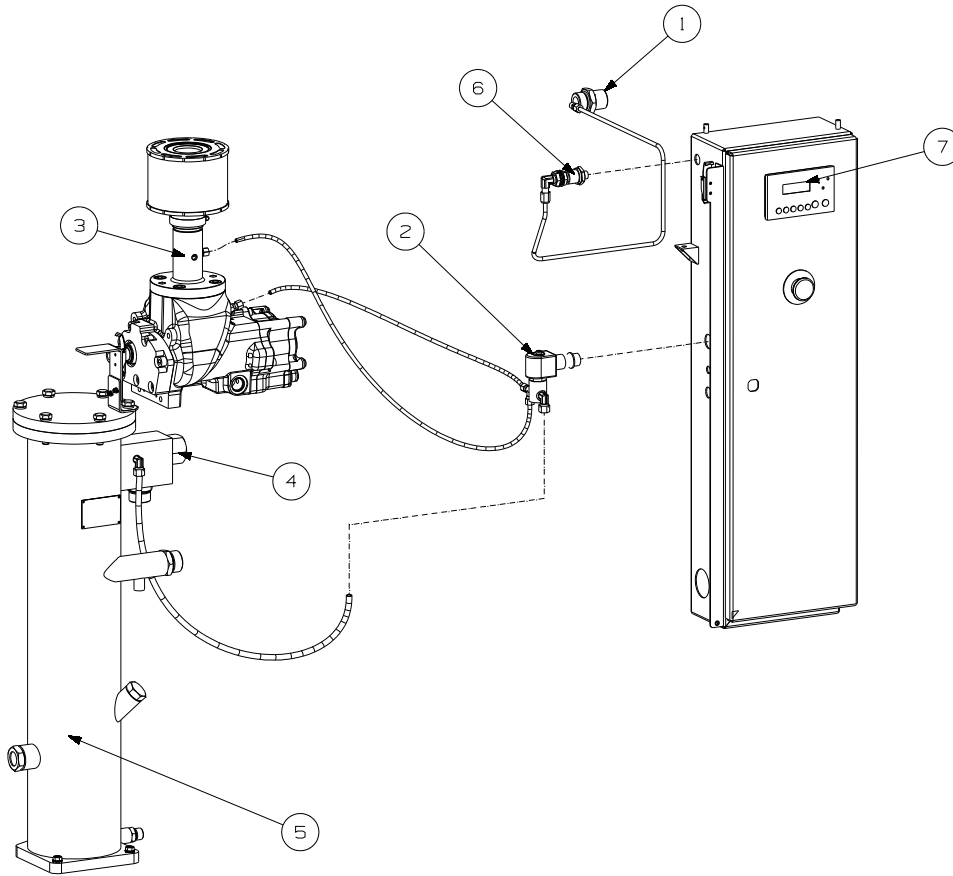

Figure 2-5: Control System, ST400, ST500, ST700, 5-10 HP

1. Air Outlet	5. Separator Tube
2. Unload Solenoid Valve	6. Pressure Transducer
3. Air Inlet	7. Controller
4. Minimum Pressure/Check Valve	8. Check Valve



**Figure 2-6: Control System, ST1100, ST1500, 15-20 HP**

1. Air Outlet	5. Separator Tube
2. Unload Solenoid Valve	6. Pressure Transducer
3. Air Inlet	7. Controller
4. Minimum Pressure/Check Valve	

service line pressure will rise. The Controller de-energizes the solenoid valve when the pressure exceeds 127 psig (8.8 bar) allowing the separator tube air pressure to be supplied directly which closes the inlet valve. At the same time the solenoid valve exhausts the system pressure to the atmosphere and lowers the separator tube pressure to approximately 29 psig (2.0 bar). A check valve in the air service line prevents air from back-flowing to the separator tube.

When the pressure drops to the low setting: (cut-in pressure) usually 112 psig (7.7 bar) for high pressure (9 bar) compressors, 137 psig (9.4 bar) for (10 bar) compressors, 161 psig (11.1 bar) for (12 bar) compressors: the Controller energizes the solenoid valve and prevents line pressure from reaching the inlet control valve.

## 2.6 AIR INLET SYSTEM, FUNCTIONAL DESCRIPTION

Refer to *Figure 2-7* and *Figure 2-8*. The **compressor inlet system** consists of a **dry-type air filter** and an **air inlet valve**.

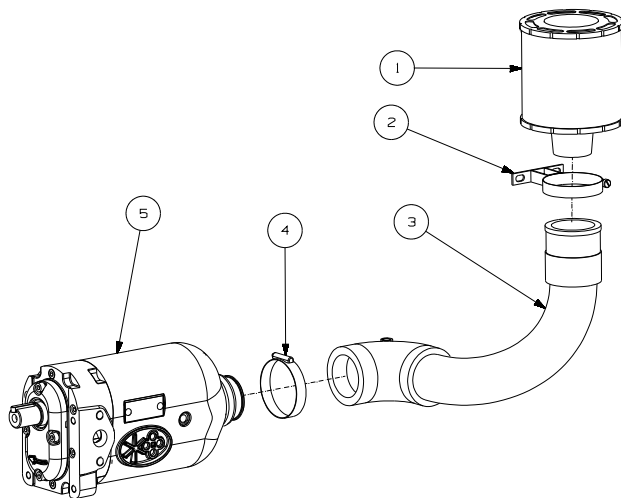

**Figure 2-7: Air Inlet System-ST400, ST500, ST700, 5-10 HP**

1. Air Inlet Filter	4. Clamp
2. Clamp	5. Compressor Unit
3. Inlet Tube	

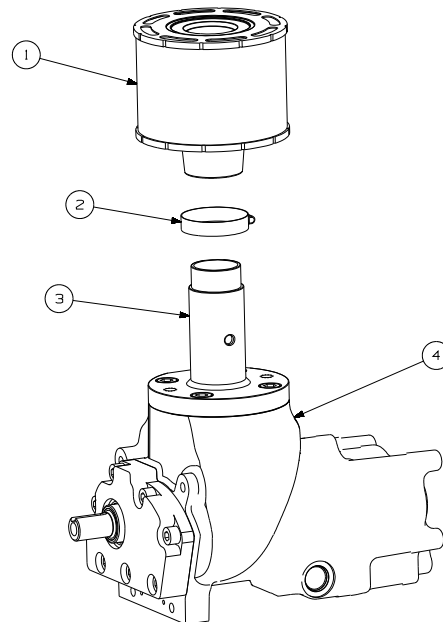

**Figure 2-8: Air Inlet System-ST1100, ST1500, 15-20 HP**

1. Air Inlet Filter	3. Inlet Adaptor
2. Clamp	4. Compressor Unit

The poppet-type air inlet valve controls the compressor's air intake volume. Refer to *Full Load Mode - 50 to 127 psig (3.4 to 8.8 bar)* on page 15. The air inlet valve also acts as a check valve to prevent reverse rotation when the compressor is shut down.

### **WARNING**

"The Plastic Pipe Institute recommends against the use of thermoplastic pipe to transport compressed air or other compressed gases in exposed above ground locations, e.g. in exposed plant piping." (I) Sullube should not be used with PVC piping systems. It may affect the bond at cemented joints. Certain other plastic materials may also be affected.

(I) Plastic Pipe Institute, Recommendation B, Adopted January 19, 1972.

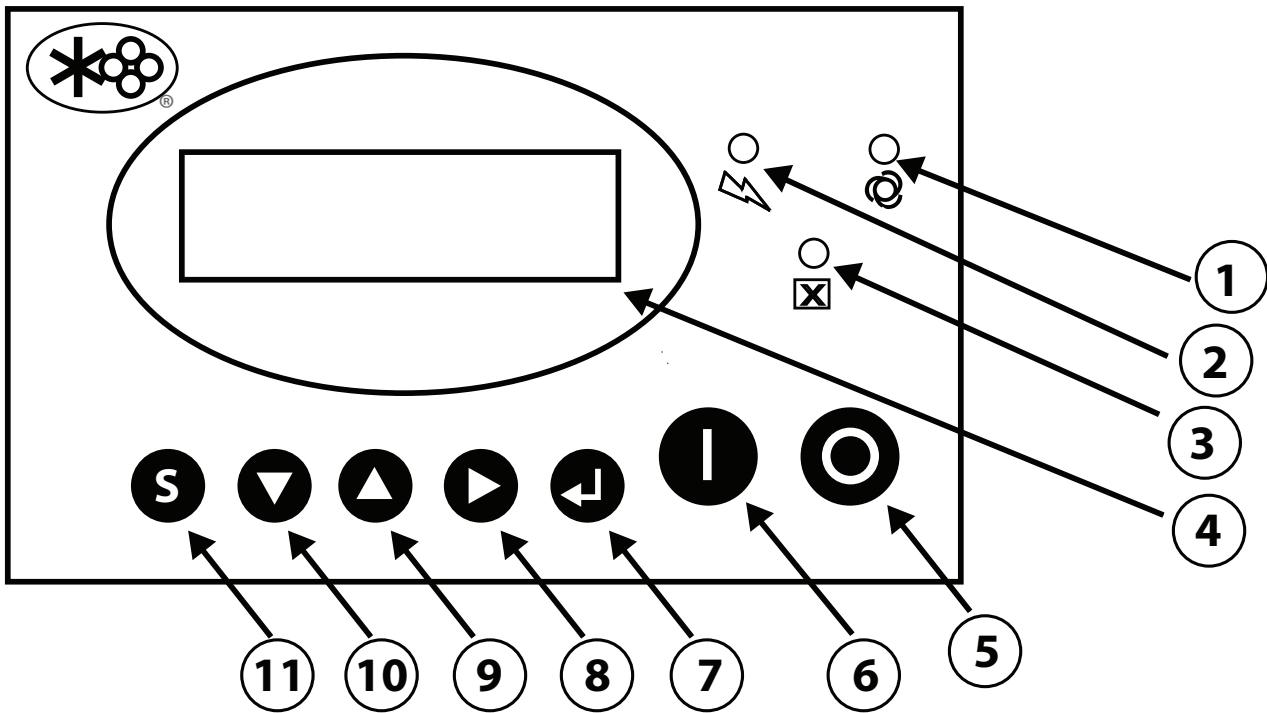

Figure 2-9: Controller Panel

1. Run Mode Indicator Light (Green)	6. Start Button
2. Power On Indicator Light (Red)	7. Return/Reset Button
3. Fault Warning Indicator Light (Red)	8. Cursor/Confirm Button
4. Display Panel	9. Up Button
5. Stop Button	10. Down Button
	11. Set/Load/Unload Button

## 2.7 CONTROLLER/KEYPAD

Refer to *Figure 2-9*. The Controller keypad has two main pads for compressor control. To start the compressor operation, press the green Start pad ①.

To stop compressor operation, press the red Stop pad ⑤. The Run mode indicator ① lights up whenever the control is in an operating mode.

## 2.8 LCD DISPLAY

The display's normal view shows the compressor

package's discharge pressure, internal temperature, operating mode, and load status. The modes are MANUAL, STOP, AUTOMATIC, or FAULT.

Refer to *Figure 2-10*. If a machine fault occurs, the red fault ③ indicator will light up, and the display will indicate that a fault has occurred.



Figure 2-10

The lower line will display the cause of the fault. Refer to service instructions to correct the cause. Press and hold the Return/Reset pad  to reset the controller.

Refer to *Figure 2-11*. Press the Down arrow  to display additional information about the compressor. The upper line will indicate the name of the temperature, pressure, or other measurement. The lower line indicates the present reading.







**TOTAL RUN TIME:**  
**337H 20M**

*Figure 2-11*

Refer to *Figure 2-12*. When you continue beyond the status information, the display will show a list of control settings. There are customer and factory settings. The upper line will indicate the name of the setting. The lower line displays the present value.

**LOAD PRESS:**  
**0110PSI**

*Figure 2-12*

Refer to *Figure 2-13* and *2-14*. To change a selected setting press  and an interface will display where a password is needed. Use  and  to change values of each digit. Use  to move to next digit. After all digits of the password have been accepted, press . Upon acceptance of password, the setting can be modified. Use buttons as above to change values. Press  to accept changes.

**PASSWORD \*\*\*\*\***



*Figure 2-13*

**LOAD PRESS:**  
**0110PSI**

*Figure 2-14*

Refer to *Figure 2-14*. If there is no keypad activity, the display will return to normal view in about one minute. If the Start, Stop or Return/Reset buttons are pressed, the display also returns to normal view. If any of these occur, the setting will not be altered.

If there are any warnings or recommended service instructions, these will be periodically displayed on the normal view.

The list of displays may be navigated from either direction by using the Up  or Down  arrow keys.

The Emergency Stop button located near the controller overrides all electronic functions to turn off the control devices. The controller senses this and will display E-stop. To reset, twist and pull out the Emergency Stop button.

## 2.9 LED LIGHTS

The three LED lights indicate the general conditions of the machine.

The Power indicator  indicates power is supplied to the controller.

The Run mode indicator  indicates compressor operation is enabled. It lights steadily if the motor is running.

The red Fault indicator  indicates that a compressor fault has occurred and needs to be repaired before further operation. The text display will indicate the cause of the fault.

# NOTES

---

## Section 3

# SPECIFICATIONS

### 3.1 TABLE OF SPECIFICATIONS

Model (I)	HP	Hz	DIMENSIONS							
			Length		Width		Height		Weight	
			in	mm	in	mm	in	mm	lbs	kg
<b>ST400 Series</b>										
ST410	5	60	32.5	826	21.5	546	37	940	524	238
ST410	5	50	32.5	826	21.5	546	37	940	524	238
<b>ST500 Series</b>										
ST510	7.5	60	32.5	826	21.5	546	37	940	546	248
ST510	7.5	50	32.5	826	21.5	546	37	940	546	248
<b>ST700 Series</b>										
ST709	10	60	32.5	826	21.5	546	37	940	567	258
ST712	10	60	32.5	826	21.5	546	37	940	567	258
ST708	10	50	32.5	826	21.5	546	37	940	567	258
ST713	10	50	32.5	826	21.5	546	37	940	567	258
<b>ST1100 Series</b>										
ST1109	15	60	39.3	998	24.3	618	40.7	1035	772	350
ST1112	15	60	39.3	998	24.3	618	40.7	1035	772	350
ST1108	15	50	39.3	998	24.3	618	40.7	1035	772	350
ST1113	15	50	39.3	998	24.3	618	40.7	1035	772	350
<b>ST1500 Series</b>										
ST1509	20	60	39.3	998	24.3	618	40.7	1035	805	365
ST1512	20	60	39.3	998	24.3	618	40.7	1035	805	365
ST1508	20	50	39.3	998	24.3	618	40.7	1035	805	365
ST1513	20	50	39.3	998	24.3	618	40.7	1035	805	365
(I) Rated pressure designations appearing after model number are as follows:										
08 - 115 psig (7.9 bar)							12 - 175 psig (12.0 bar)			
09 - 125 psig (8.6 bar)							13 - 188 psig (13.0 bar)			
10 - 150 psig (10.3 bar) 60HZ										
10 - 145 psig (10 bar) 50HZ										
Unload pressure is the same as rated pressure. Load pressure is rated pressure minus 15 psig (1 bar)										
(II) For tankmount and dryer dimensions see <i>Figure 3.6</i> on page 36.										

**3.2 COMPRESSOR SPECIFICATIONS**

<b>COMPRESSOR:</b>	<b>STANDARD MODELS:</b>
Type:	Fluid Flooded Rotary Screw
Standard Operating Pressure:	115 psig (8 bar) / 125 psig (8.6 bar)/145 psig (10.0 bar)/ 150 psig (10.3 bar) 175 psig (12.0 bar)/188 psig (13.0 bar)
Bearing Type:	Anti-friction
Ambient Temperature (Max.)	104°F (40°C)

**3.3 LUBRICATION GUIDE**

Refer to *Figure 3-1* for the fluid fill port location. Sullair’s ShopTek series compressors are filled and tested at the factory with Sullube lubricant.

**⚠ CAUTION**

Do not mix different types of lubricants. Mixing lubricants can cause malfunctions or compressor damage: will void the compressor’s warranty.

**⚠ CAUTION**

Contamination of compressor fluids with mineral oil or other fluids can cause foaming, filter plugging, or orifice line obstruction.

**3.4 APPLICATION GUIDE**

Sullair encourages its customers to participate in a fluid analysis program with the fluid suppliers. In some cases the analysis results suggest a fluid change interval which differs from the User Manual. Contact a Sullair representative for details.



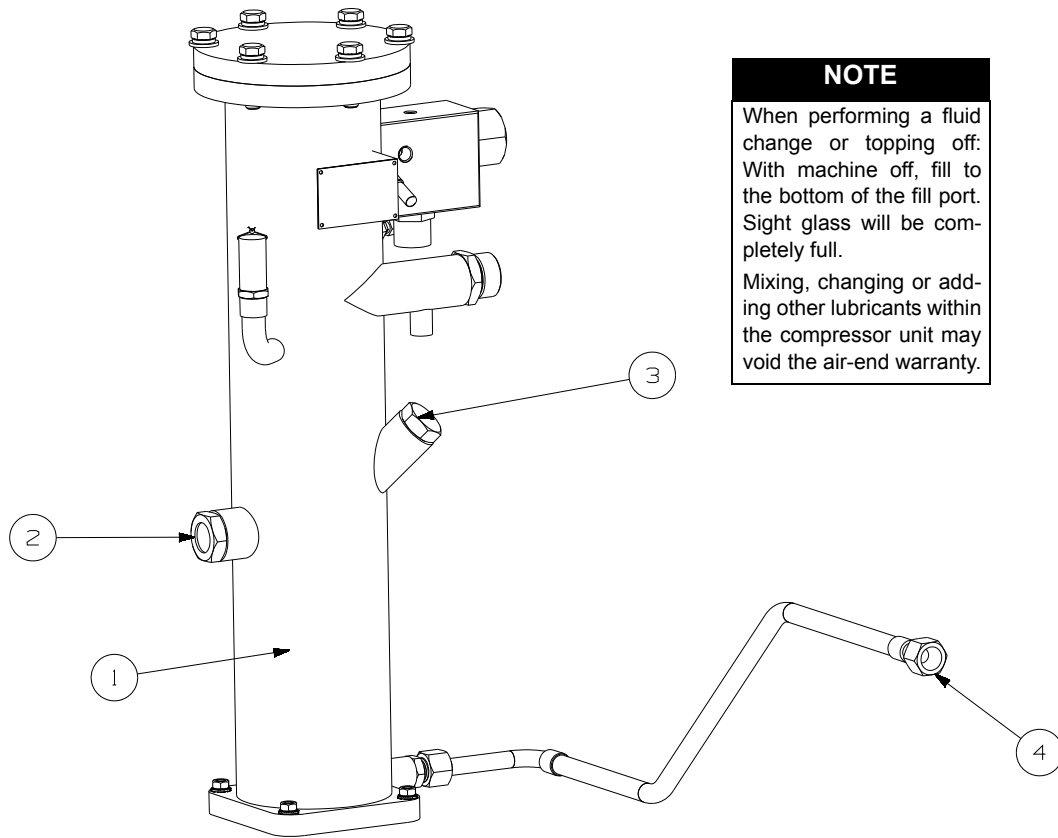

**NOTE**  
 When performing a fluid change or topping off: With machine off, fill to the bottom of the fill port. Sight glass will be completely full.  
 Mixing, changing or adding other lubricants within the compressor unit may void the air-end warranty.

Figure 3-1: Fluid Fill Location

1. Separator Tube	3. Fluid Fill Port
2. Sight Glass	4. TO DRAIN-disconnect oil line from cooler

### 3.5 LUBRICATION CHANGE RECOMMENDATIONS AND MAINTENANCE, FLUID FILTER AND SEPARATOR

LUBRICANT	FLUID CHANGE	FILTER CHANGE	SEPARATOR CHANGE
Sullube (l)	A	B	C
A - 8000 hours or 1 year, whichever occurs first. B - 2000 Hours C - 4000 Hours			
(l) ST400, ST500, ST700 - 1 Gallon (4 Liters) ST1100, ST1500 - 1.3 gallon (5 Liters)			

Figure 3-2: Identification - ST400, ST500, ST700, 5-10HP

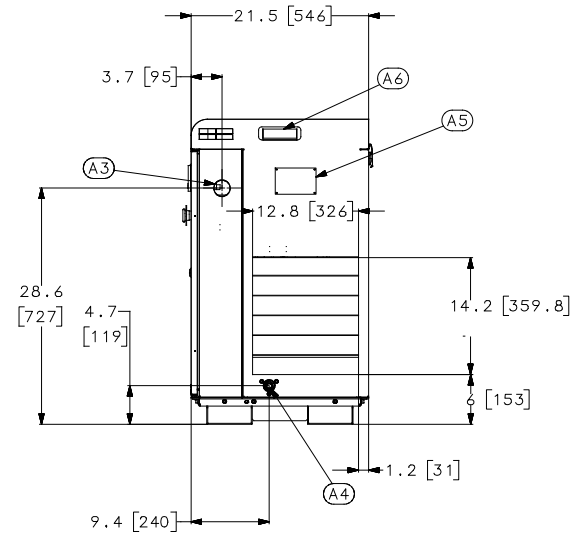
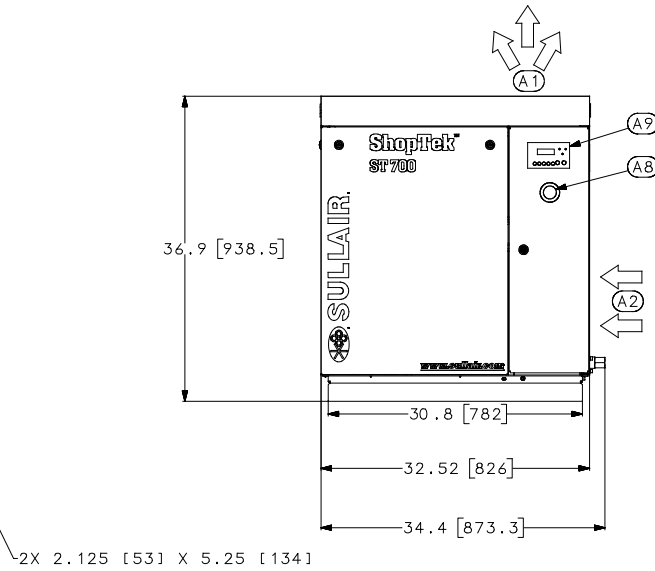
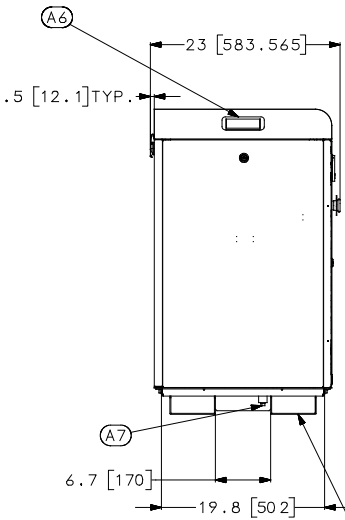
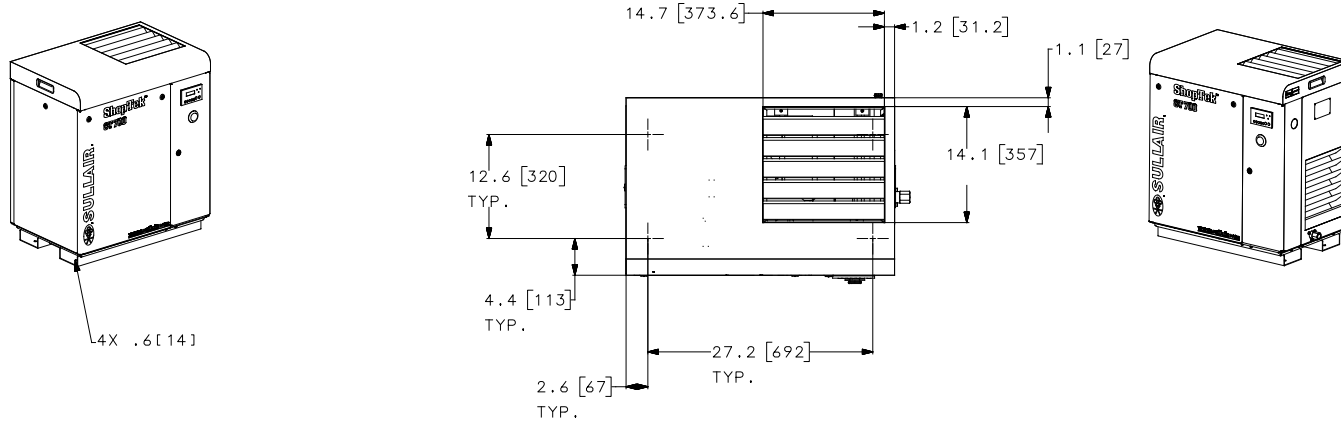

02250180-090 R00



02250179-432 R00

**Identification - ST400, ST500, ST700, 5-10HP**

SEE TABLE NOTES:	
1. ALLOW 4.00 FEET [1.25 METERS] MINIMUM CLEARANCE AROUND MACHINE FOR ACCESS AND FREE CIRCULATION OF AIR.	
2. A FOUNDATION OR MOUNTING CAPABLE OF SUPPORTING THE WEIGHT OF PACKAGE, AND RIGID ENOUGH TO MAINTAIN THE COMPRESSOR FRAME LEVEL IS REQUIRED.	
3. ALL DIMENSIONS ARE +/- .50" [12.7MM]	
4. RECOMMENDED INCOMING CUSTOMER POWER SUPPLY IS SHOWN ON DRAWING.	
5. DOORS ARE REMOVABLE USING LIFT-OFF PINS.	
6. ALL DIMENSIONS SHOWN IN INCHES WITH MILLIMETER DIMENSIONS IN BRACKETS.	
A1: EXHAUST AIR OUT	
A2: AIR INLET	
A3: INCOMING CUSTOMER POWER SUPPLY 1.96[50]DIA	
A4: AIR OUT CONNECTION 3/4"NPT	
A5: SERIAL PLATE	
A6: HAND HOLD	
A7: CONTAINMENT PAN DRAIN 1/4"NPT	
A8: E-STOP	
A9: CONTROLLER	
MACHINE WEIGHTS	
ST400	524LBS[238KG]
ST500	546LBS[248KG]
ST700	567LBS[258KG]

Figure 3-3: Identification - ST1100, ST1500, 15-20HP

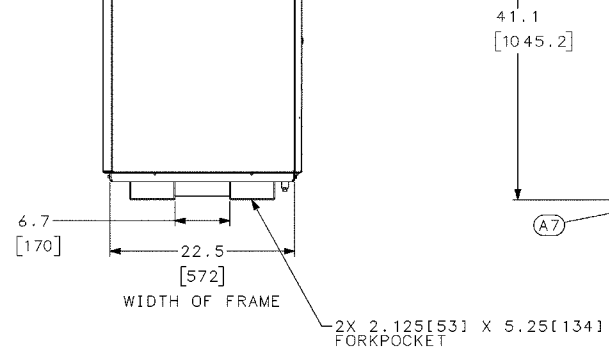
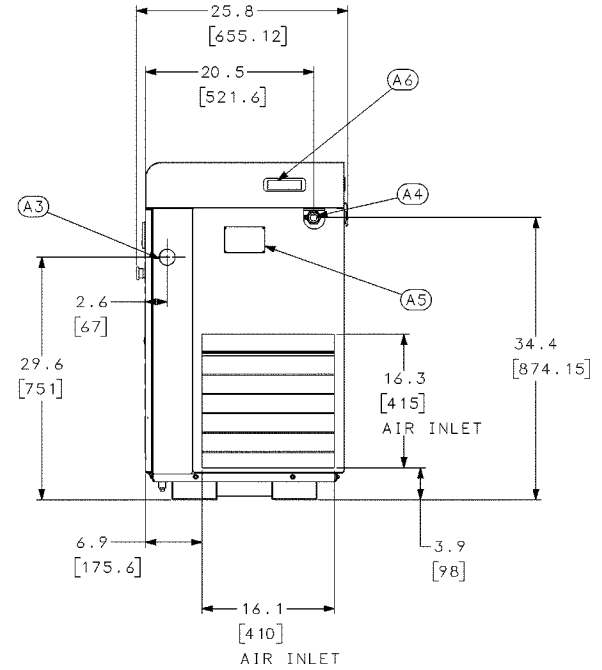
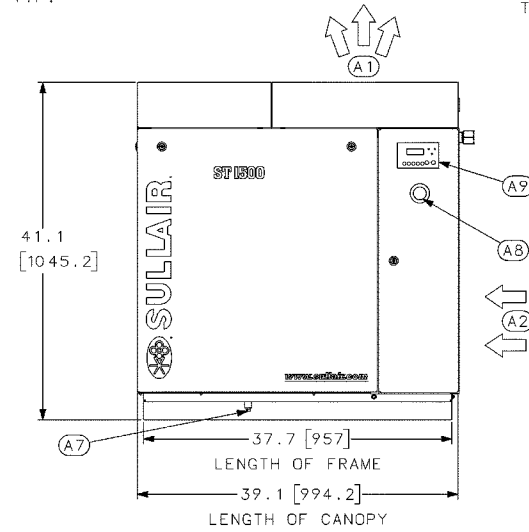
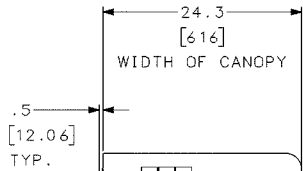
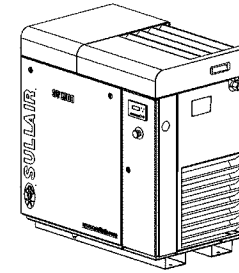
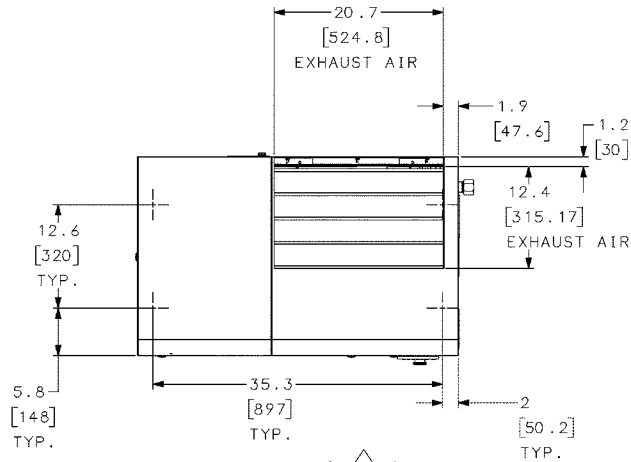
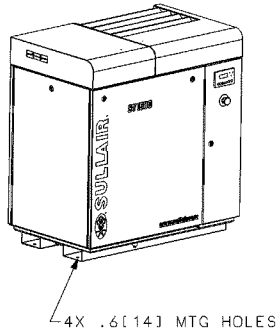

02250180-090 R00



02250179-435 R01

**Identification - ST1100, ST1500, 15-20HP**

SEE TABLE NOTES:	
1. ALLOW 4.00 FEET [1.25 METERS] MINIMUM CLEARANCE AROUND MACHINE FOR ACCESS AND FREE CIRCULATION OF AIR.	
2. A FOUNDATION OR MOUNTING CAPABLE OF SUPPORTING THE WEIGHT OF PACKAGE, AND RIGID ENOUGH TO MAINTAIN THE COMPRESSOR FRAME LEVEL IS REQUIRED.	
3. ALL DIMENSIONS ARE +/- .50" [12.7MM]	
4. RECOMMENDED INCOMING CUSTOMER POWER SUPPLY IS SHOWN ON DRAWING.	
5. DOORS ARE REMOVABLE USING LIFT-OFF PINS.	
6. ALL DIMENSIONS SHOWN IN INCHES WITH MILLIMETER DIMENSIONS IN BRACKETS.	
A1: EXHAUST AIR OUT	
A2: AIR INLET	
A3: INCOMING CUSTOMER POWER SUPPLY 1.96[50]DIA	
A4: AIR OUT CONNECTION 1"NPT	
A5: SERIAL PLATE	
A6: HAND HOLD	
A7: CONTAINMENT PAN DRAIN 1/4"NPT	
A8: E-STOP	
A9: CONTROLLER	
MACHINE WEIGHTS	
ST1100	772LBS[350KG]
ST1500	805LBS[365KG]

Figure 3-4: Piping and Instrumentation - ST400, ST500, ST700, 5-10HP

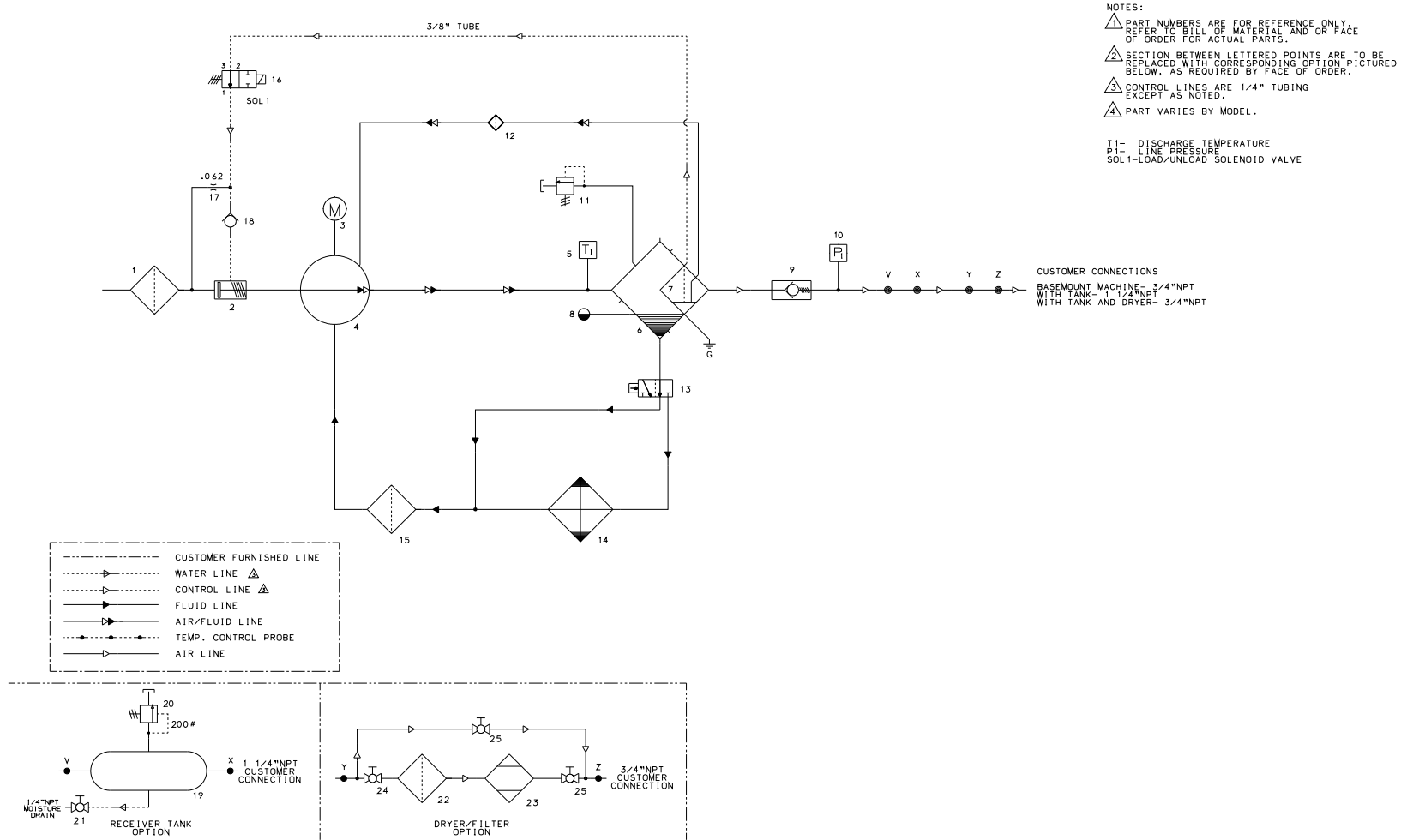

02250180-090 R00



02250179-804 R01

**Piping and Instrumentation - ST400, ST500, ST700, 5-10HP**

KEY NO.	PART NO.	QTY	DESCRIPTION	NOTE
1	88290014-486	1	FILTER,AIR	
2	-	1	VALVE,INLET INTEGRAL	
3	VARIOUS	1	MOTOR,ELECTRIC	
4	02250171-669	1	UNIT,COMPRESSOR	
5	88290014-534	1	PROBE,TEMP	
6	88290015-814	1	SEPARATOR TUBE	
7	88290015-049	1	ELEMENT,OIL SEPARATOR	
8	88290014-222	1	OIL SIGHT GLASS	
9	02250046-338	1	VALVE,MINIMUM PRESSURE	
10	88290014-514	1	SENSOR,PRESSURE	
11	VARIOUS	1	VALVE,RELIEF	
12	88290015-890	1	FILTER,RETURN OIL	
13	VARIOUS	1	VALVE,THERMAL	
14	88290015-765	1	COOLER,OIL	
15	88290014-484	1	FILTER,OIL	
16	88290015-219	1	VALVE,SOLENOID	
17	40127	1	ORIFICE, 0.062"	
18	02250110-557	1	VALVE,CHECK	
19	02250170-199	1	TANK,RECEIVER 80 GAL	
20	250006-938	1	VALVE,PRESSURE RELIEF 200#	
21	47115	1	VALVE,BALL 1/4"NPT	
22	VARIOUS	1	FILTER,SCF	
23	VARIOUS	1	DRYER,SRS	
24	VARIOUS	1	VALVE, BALL	
25	47118	2	VALVE,BALL 3/4"NPT	

Figure 3-5: Piping and Instrumentation - ST1100 and ST1500, 15-20HP

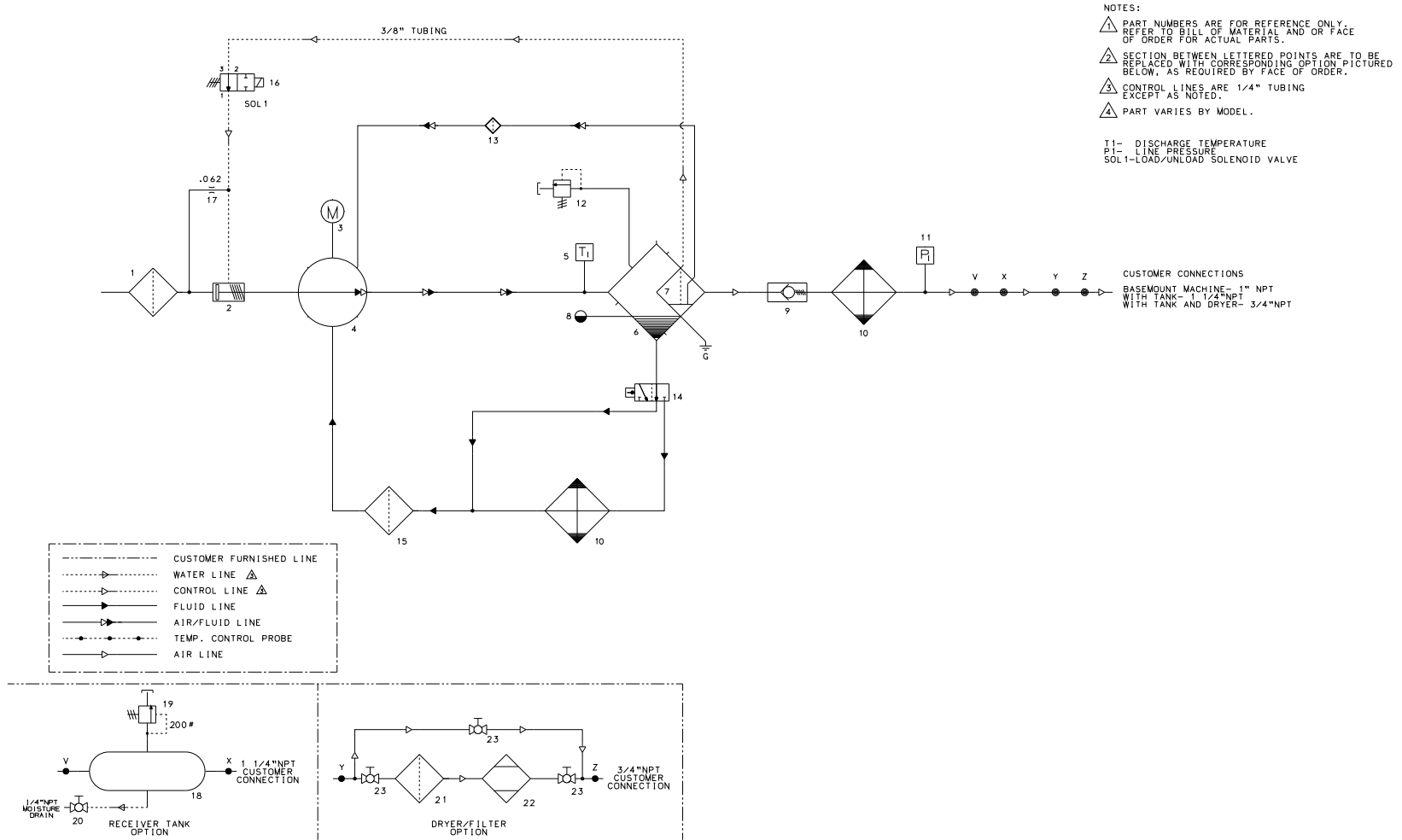

02250180-090 R00



02250179-805 R02



**Piping and Instrumentation - ST1100 and ST1500, 15-20HP**

KEY NO.	PART NO.	QTY	DESCRIPTION	NOTE
1	88290014-485	1	FILTER,AIR	
2	-	1	VALVE,INLET INTEGRAL	
3	VARIOUS	1	MOTOR,ELECTRIC	
4	88290015-893	1	UNIT,COMPRESSOR	
5	88290014-534	1	PROBE,TEMP	
6	88290014-226	1	SEPARATOR TUBE	
7	88290015-567	1	ELEMENT,OIL SEPARATOR	
8	88290014-222	1	OIL SIGHT GLASS	
9	02250046-338	1	VALVE,MINIMUM PRESSURE	
10	88290014-225	1	COMBINATION AIR/OIL COOLER	
11	88290014-514	1	SENSOR,PRESSURE	
12	VARIOUS	1	VALVE,RELIEF	
13	88290015-890	1	FILTER,RETURN OIL	
14	VARIOUS	1	VALVE,THERMAL	
15	88290014-484	1	FILTER,OIL	
16	88290015-219	1	VALVE,SOLENOID	
17	040127	1	ORIFICE, 0.062"	
18	02250170-200	1	TANK,RECEIVER 120 GAL	
19	250006-938	1	VALVE,PRESSURE RELIEF 200#	
20	047115	1	VALVE,BALL 1/4"NPT	
21	VARIOUS	1	FILTER,SCF	
22	VARIOUS	1	DRYER,SRS	
23	047118	2	VALVE,BALL 3/4"NPT	

Figure 3-6: Wiring Diagram - ST400-ST1500 208V-460V Full Voltage

TECHNICAL REQUIREMENTS  
 1. CUSTOMER TO FURNISH POWER INLET PROTECTION  
 2. CUSTOMER TO FURNISH REMOTE START/STOP BUTTON

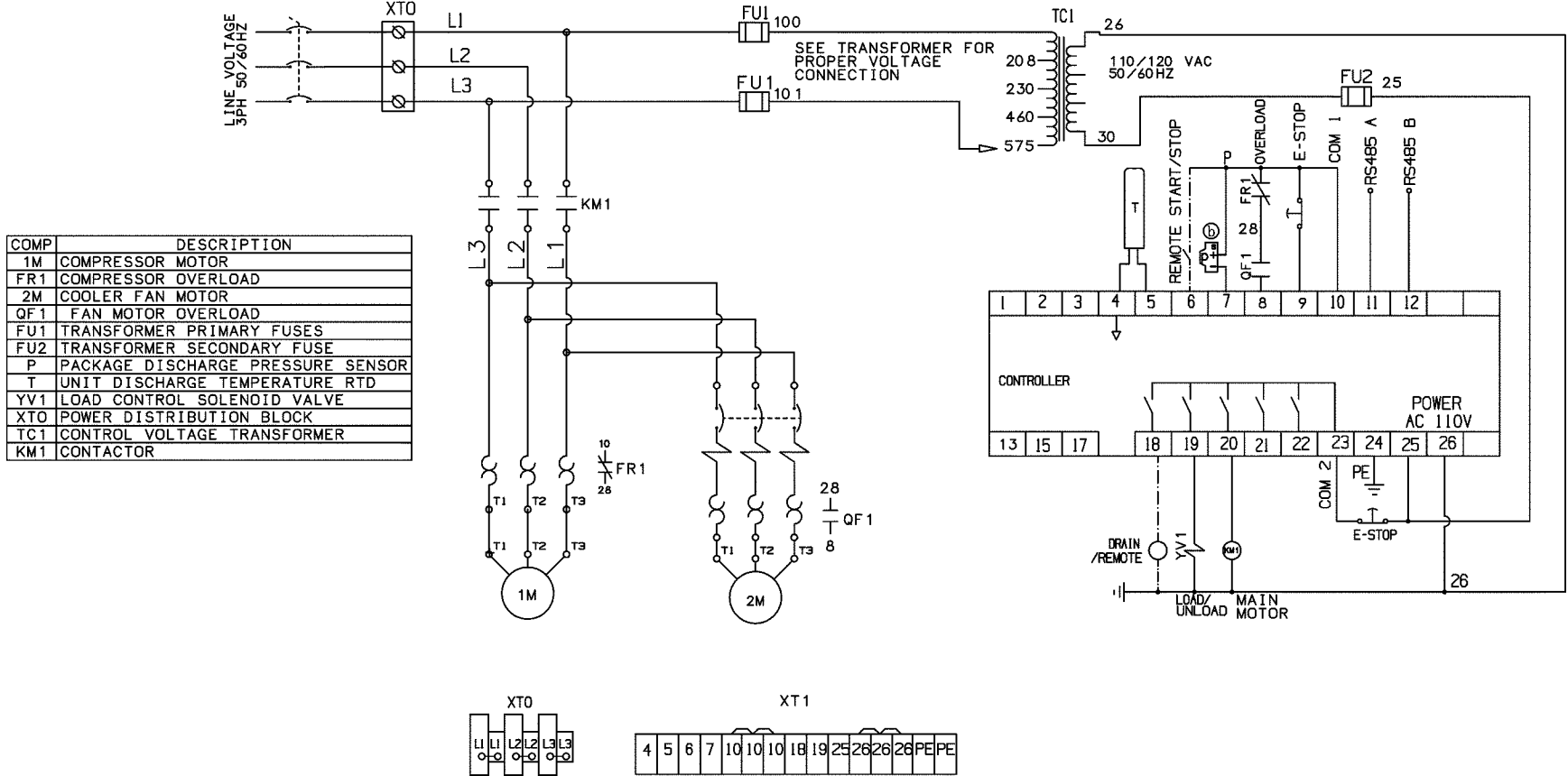

02250180-090 R00



88290015-618 R0

**Figure 3-7: Wiring Diagram - ST400-ST1500 575V Full Voltage**

Figure 3-8: Wiring Diagram - ST400, ST500, ST700 400V/50Hz CE Full Voltage



02250180-090 R00

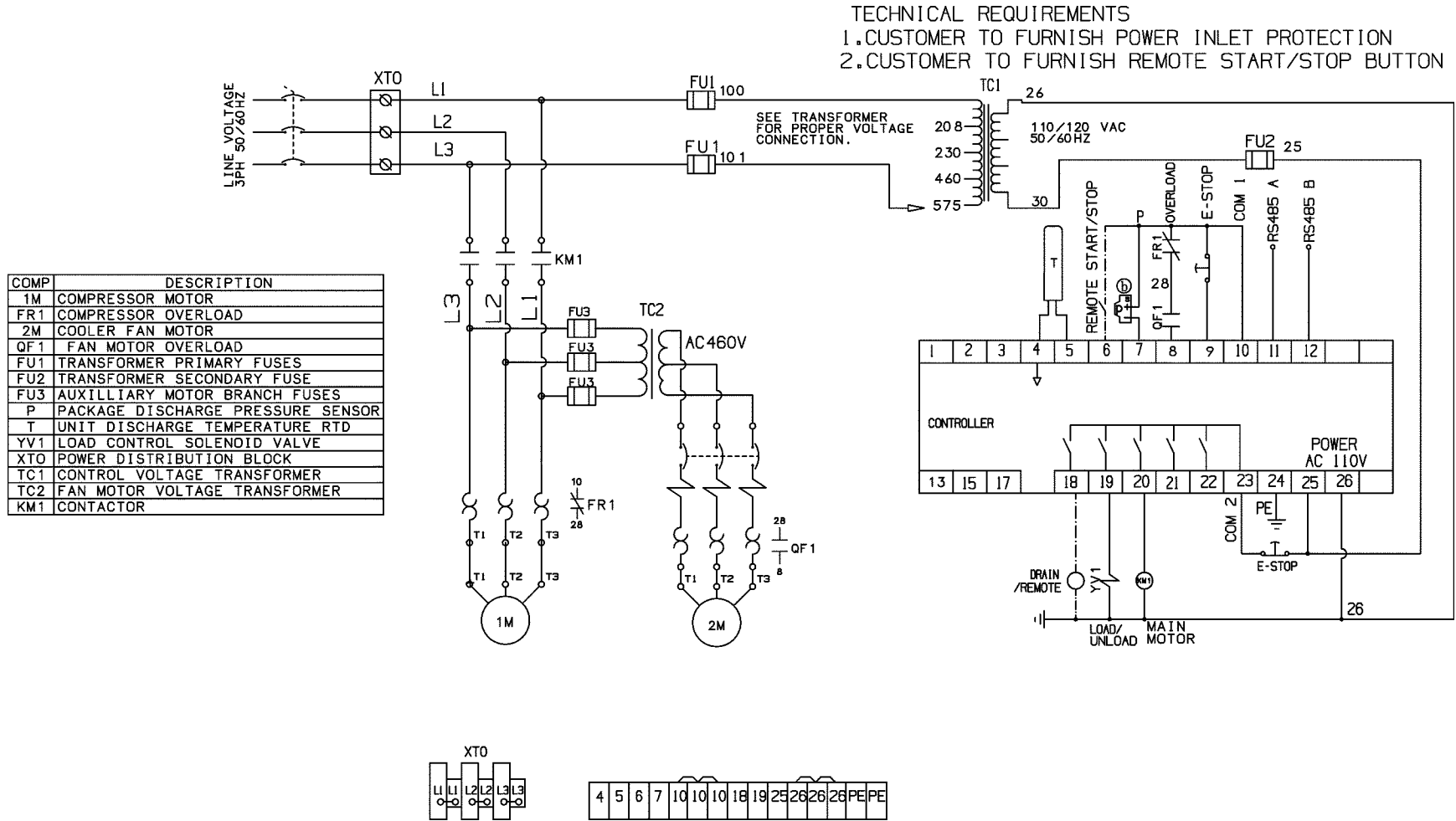
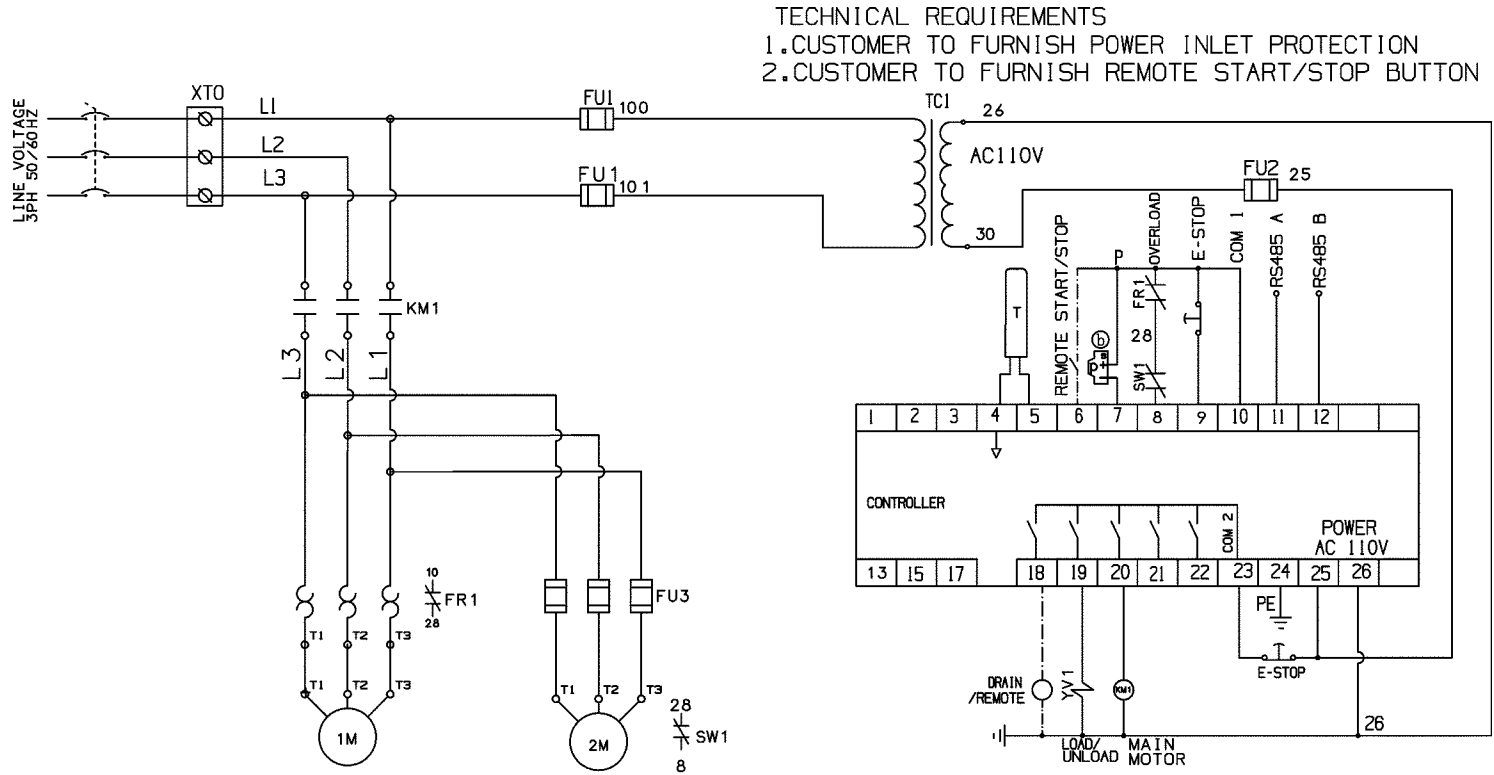

COMP	DESCRIPTION
1M	COMPRESSOR MOTOR
FR1	COMPRESSOR OVERLOAD
2M	COOLER FAN MOTOR
SW1	NORMALLY CLOSED SWITCH CONTACT
FU1	TRANSFORMER PRIMARY FUSES
FU2	TRANSFORMER SECONDARY FUSE
FU3	FAN MOTOR BRANCH FUSES
P	PACKAGE DISCHARGE PRESSURE SENSOR
T	UNIT DISCHARGE TEMPERATURE RTD
YV1	LOAD CONTROL SOLENOID VALVE
XT0	POWER DISTRIBUTION BLOCK
TC1	CONTROL VOLTAGE TRANSFORMER
KM1	CONTACTOR

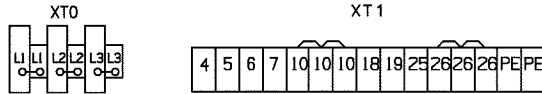

88290014-361 R07

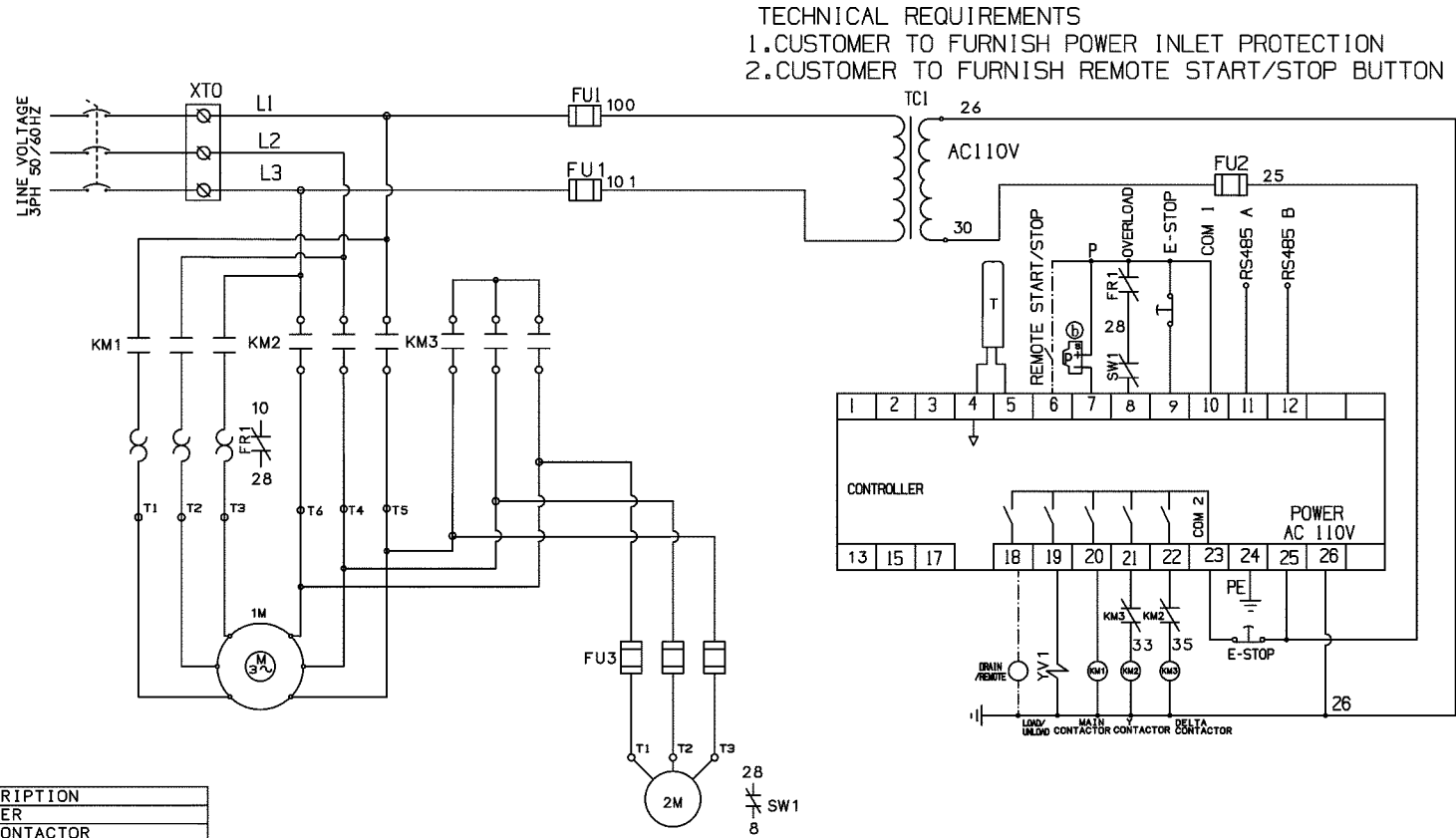
**Figure 3-9: Wiring Diagram - ST1100-ST1500 400V/50Hz CE Wye-Delta**

COMP	DESCRIPTION
KM1	WYE-DELTA STARTER
KM2	WYE-DELTA RUN CONTACTOR
KM3	WYE-DELTA START CONTACTOR
FR1	COMPRESSOR OVERLOAD
1M	COMPRESSOR MOTOR
2M	COOLER FAN MOTOR
SW1	NORMALLY CLOSED SWITCH CONTACT
FU1	TRANSFORMER PRIMARY FUSES
FU2	TRANSFORMER SECONDARY FUSE
FU3	FAN MOTOR BRANCH FUSES
P	PACKAGE DISCHARGE PRESSURE SENSOR
T	UNIT DISCHARGE TEMPERATURE RTD
YV1	LOAD CONTROL SOLENOID VALVE
XTO	POWER DISTRIBUTION BLOCK
TC1	CONTROL VOLTAGE TRANSFORMER

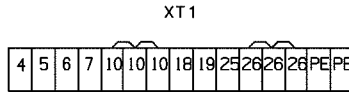
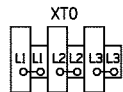

**3.6 TANK MOUNT AND DRYER OPTIONS**

Model (I)(II)	HP	DIMENSIONS							
		Length		Width		Height		Weight	
		in	mm	in	mm	in	mm	lbs	kg
<b>WS400 Series</b>									
ST400R	5	64	1616	23	591	63	1605	854	388
ST400RD	5	69	1748	23	591	63	1605	935	424
<b>WS500 Series</b>									
ST500R	7.5	64	1616	23	591	63	1605	876	398
ST500RD	7.5	69	1748	23	591	63	1605	954.5	434
<b>WS700 Series</b>									
ST700R	10	64	1616	23	591	63	1605	897	408
ST700RD	10	69	1748	23	591	63	1605	981	446
<b>WS1100 Series</b>									
ST1100R	15	66	1676	25.5	645.5	71.5	1813.5	1192	541
ST1100RD	15	71	1797	25.5	645.5	71.5	1813.5	1288	584
<b>WS1500 Series</b>									
ST1500R	20	66	1676	25.5	645.5	71.5	1813.5	1225	556
ST1500RD	20	71	1797	25.5	645.5	71.5	1813.5	1321	599
<b>(I) R - Mounted on Receiver Tank</b>									
<b>RD - Mounted on Receiver Tank with Dryer</b>									
<b>(II) For package pressure ratings see Table 3-1</b>									

# NOTES

---

Figure 3-10: Identification - ST400, ST500, ST700, 5-10HP Tank Mount

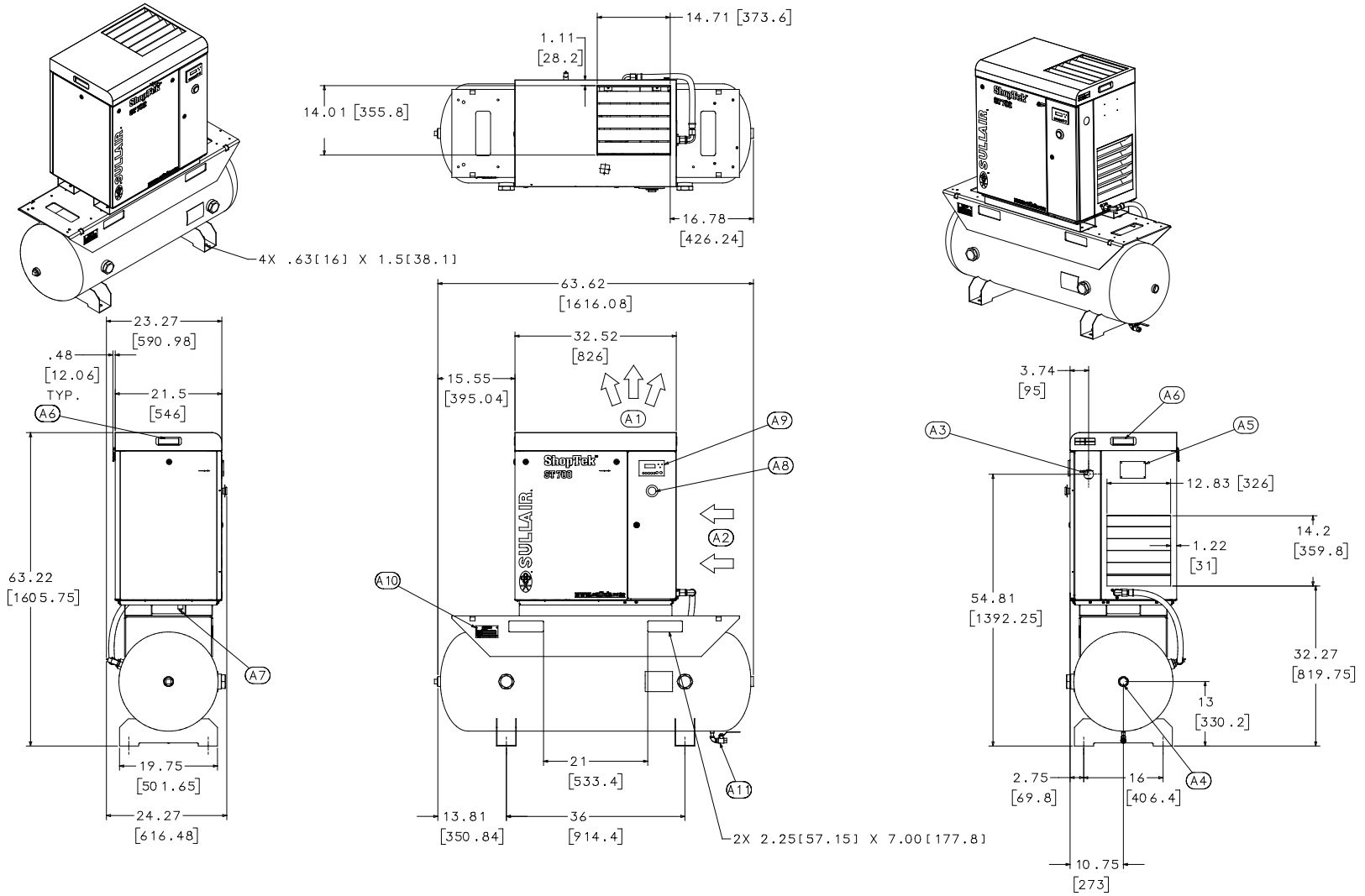



**Identification - ST400, ST500, ST700, 5-10HP Tank Mount**

SEE TABLE NOTES:	
1. ALLOW 4.00 FEET [1.25 METERS] MINIMUM CLEARANCE AROUND MACHINE FOR ACCESS AND FREE CIRCULATION OF AIR.	
2. A FOUNDATION OR MOUNTING CAPABLE OF SUPPORTING THE WEIGHT OF PACKAGE, AND RIGID ENOUGH TO MAINTAIN THE COMPRESSOR FRAME LEVEL IS REQUIRED.	
3. ALL DIMENSIONS ARE +/- .50" [12.7MM]	
4. RECOMMENDED INCOMING CUSTOMER POWER SUPPLY IS SHOWN ON DRAWING.	
5. DOORS ARE REMOVABLE USING LIFT-OFF PINS.	
6. ALL DIMENSIONS SHOWN IN INCHES WITH MILLIMETER DIMENSIONS IN BRACKETS.	
A1: EXHAUST AIR OUT	
A2: AIR INLET	
A3: INCOMING CUSTOMER POWER SUPPLY 1.96[50]DIA	
A4: AIR OUT CONNECTION 1 1/4"NPT	
A5: SERIAL PLATE	
A6: HAND HOLD	
A7: CONTAINMENT PAN DRAIN 1/4"NPT	
A8: E-STOP	
A9: CONTROLLER	
A10: TANK MOUNT SERIAL PLATE	
A11: TANK DRAIN 1/4"NPT	
MACHINE WEIGHTS	
ST400	854LBS[388KG]
ST500	876LBS[398KG]
ST700	897LBS[408KG]

Figure 3-11: Identification - ST400, ST500, ST700, 5-10HP Tank Mount with Dryer

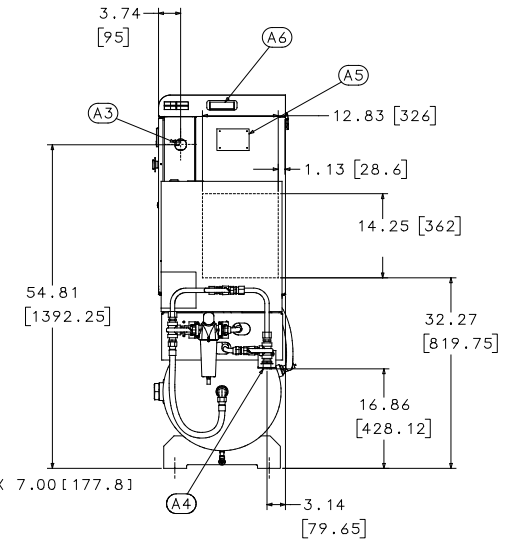
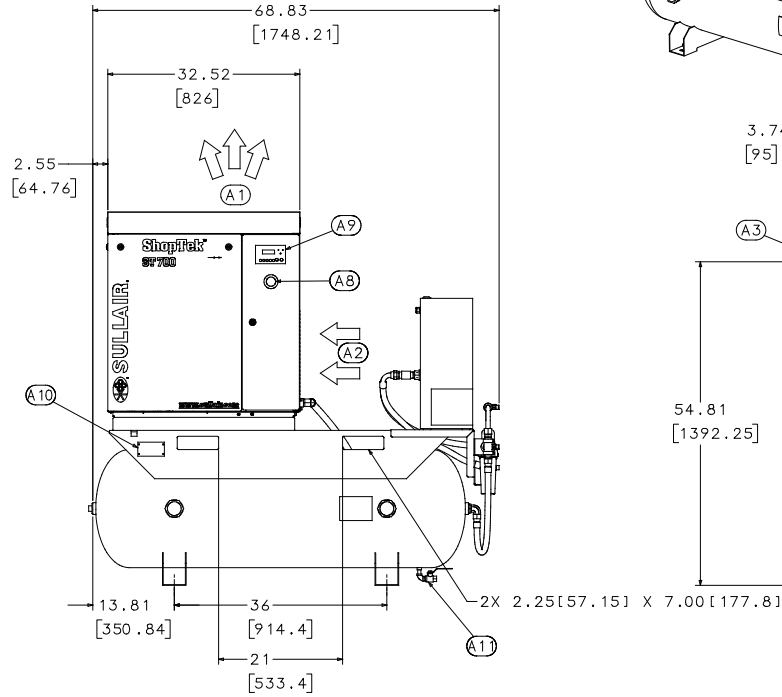
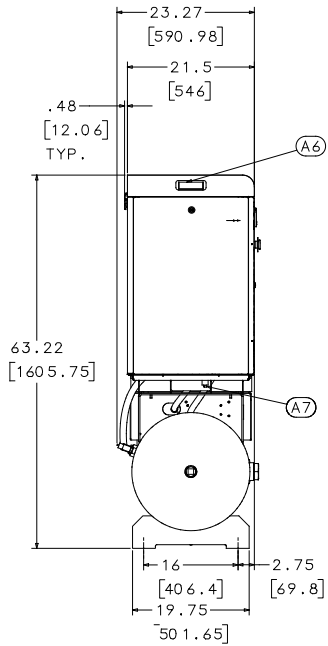
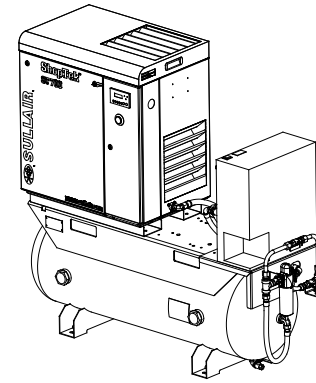
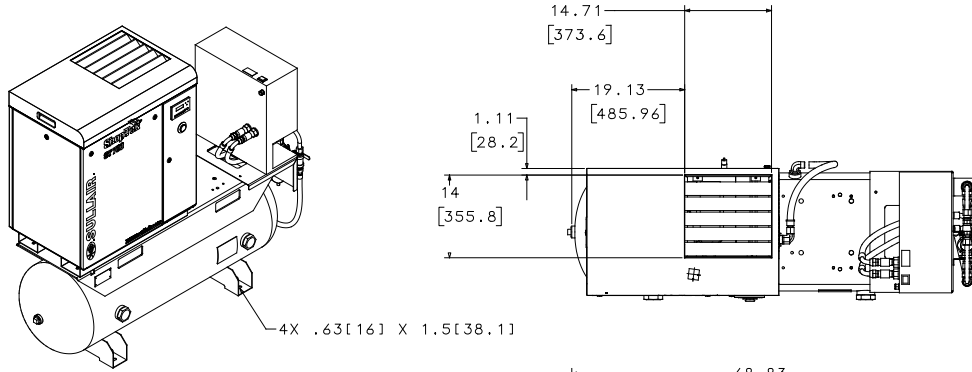

**Identification - ST400, ST500, ST700, 5-10HP Tank Mount with Dryer**

SEE TABLE NOTES:	
1. ALLOW 4.00 FEET [1.25 METERS] MINIMUM CLEARANCE AROUND MACHINE FOR ACCESS AND FREE CIRCULATION OF AIR.	
2. A FOUNDATION OR MOUNTING CAPABLE OF SUPPORTING THE WEIGHT OF PACKAGE, AND RIGID ENOUGH TO MAINTAIN THE COMPRESSOR FRAME LEVEL IS REQUIRED.	
3. ALL DIMENSIONS ARE +/- .50" [12.7MM]	
4. RECOMMENDED INCOMING CUSTOMER POWER SUPPLY IS SHOWN ON DRAWING.	
5. DOORS ARE REMOVABLE USING LIFT-OFF PINS.	
6. ALL DIMENSIONS SHOWN IN INCHES WITH MILLIMETER DIMENSIONS IN BRACKETS.	
A1: EXHAUST AIR OUT	
A2: AIR INLET	
A3: INCOMING CUSTOMER POWER SUPPLY 1.96[50]DIA	
A4: AIR OUT CONNECTION 3/4"NPT	
A5: SERIAL PLATE	
A6: HAND HOLD	
A7: CONTAINMENT PAN DRAIN 1/4"NPT	
A8: E-STOP	
A9: CONTROLLER	
A10: TANK MOUNT SERIAL PLATE	
A11: TANK DRAIN 1/4"NPT	
MACHINE WEIGHTS	
ST400	935.2LBS[423.7KG]
ST500	954.5LBS[433.7KG]
ST700	981.2LBS[446KG]

Figure 3-12: Identification - ST1100, ST1500, 15-20HP Tank Mount

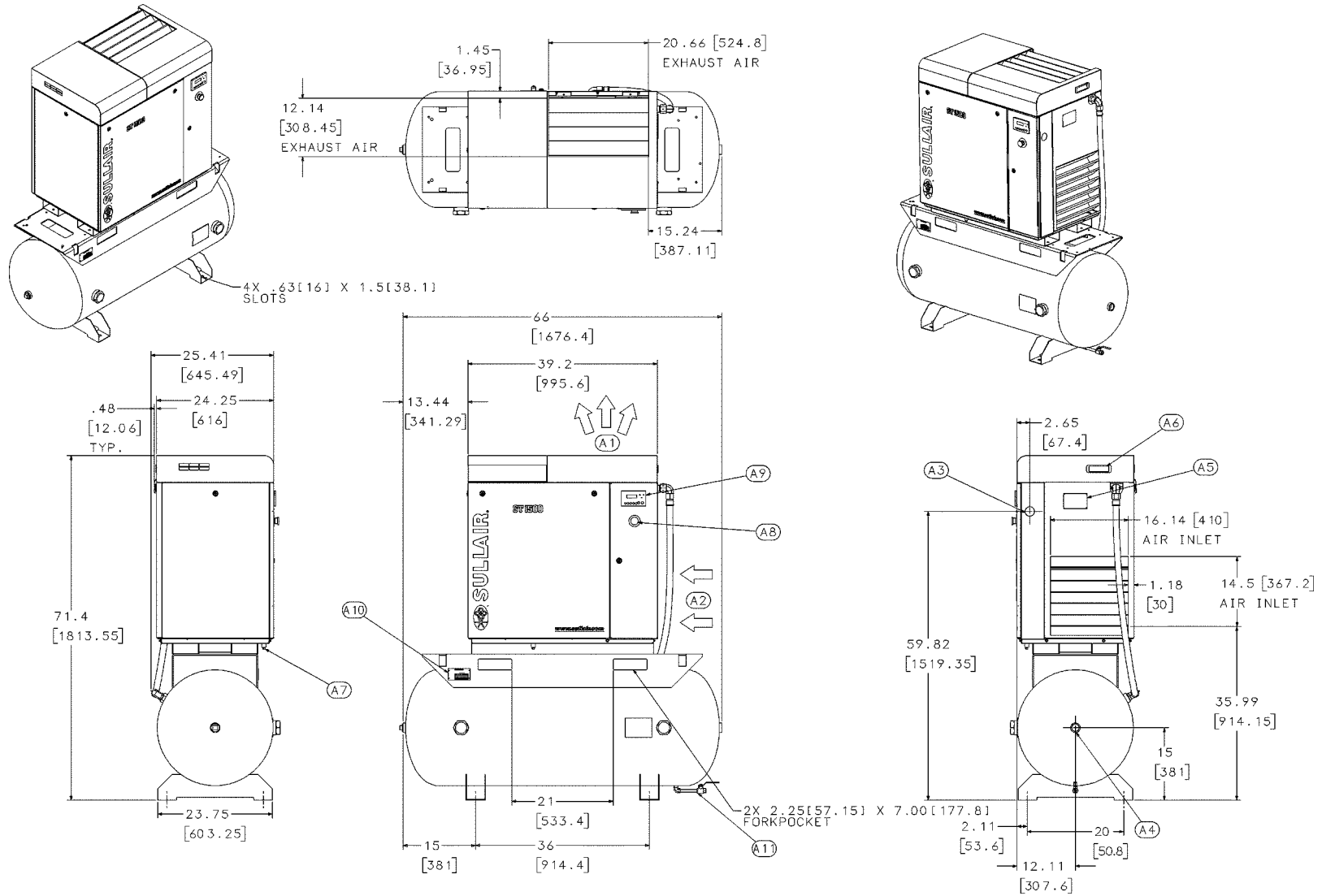

02250180-090 R00



02250179-436 R01

**Identification - ST1100, ST1500, 15-20HP Tank Mount**

SEE TABLE NOTES:	
1. ALLOW 4.00 FEET [1.25 METERS] MINIMUM CLEARANCE AROUND MACHINE FOR ACCESS AND FREE CIRCULATION OF AIR.	
2. A FOUNDATION OR MOUNTING CAPABLE OF SUPPORTING THE WEIGHT OF PACKAGE, AND RIGID ENOUGH TO MAINTAIN THE COMPRESSOR FRAME LEVEL IS REQUIRED.	
3. ALL DIMENSIONS ARE +/- .50" [12.7MM]	
4. RECOMMENDED INCOMING CUSTOMER POWER SUPPLY IS SHOWN ON DRAWING.	
5. DOORS ARE REMOVABLE USING LIFT-OFF PINS.	
6. ALL DIMENSIONS SHOWN IN INCHES WITH MILLIMETER DIMENSIONS IN BRACKETS.	
A1: EXHAUST AIR OUT	
A2: AIR INLET	
A3: INCOMING CUSTOMER POWER SUPPLY 1.96[50]DIA	
A4: AIR OUT CONNECTION 1 1/4"NPT	
A5: SERIAL PLATE	
A6: HAND HOLD	
A7: CONTAINMENT PAN DRAIN 1/4"NPT	
A8: E-STOP	
A9: CONTROLLER	
A10: TANK MOUNT SERIAL PLATE	
A11: TANK DRAIN 1/4"NPT	
MACHINE WEIGHTS	
ST1100	1192LBS[541KG]
ST1500	1225LBS[556KG]

Figure 3-13: Identification - ST1100, ST1500, 15-20HP Tank Mount with Dryer

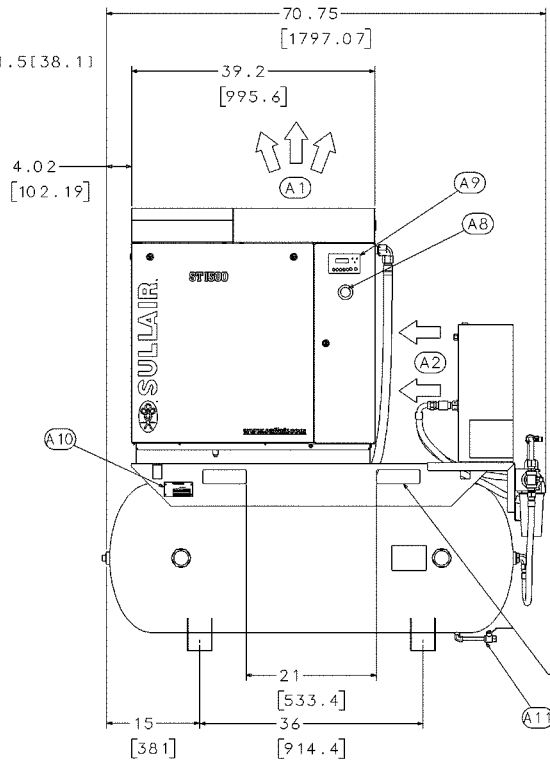
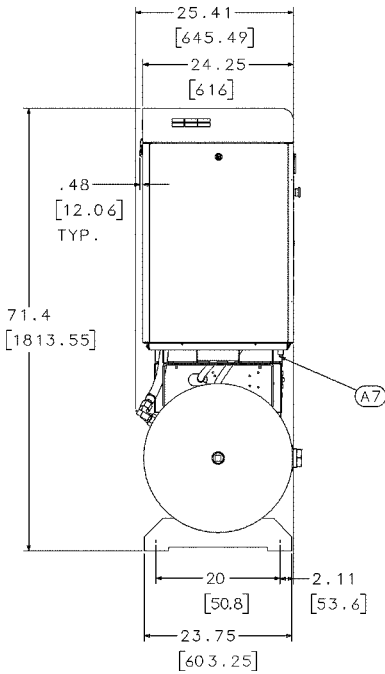
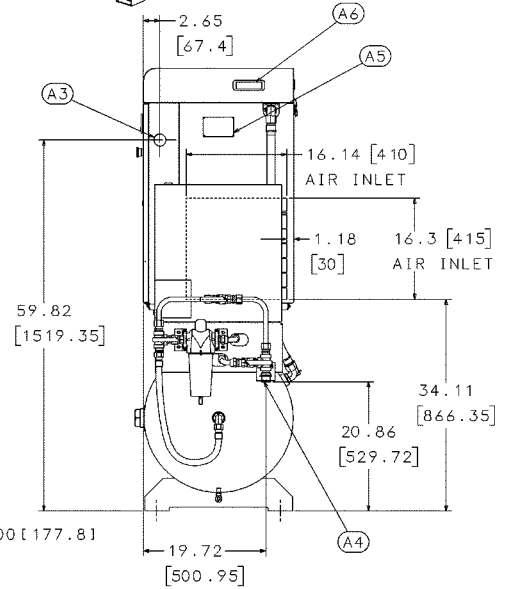
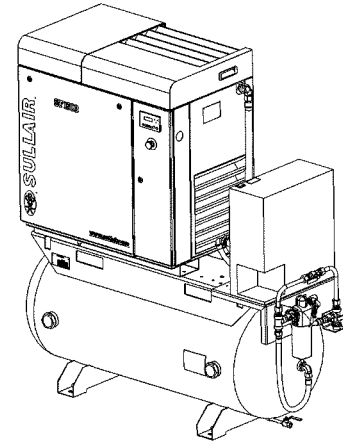
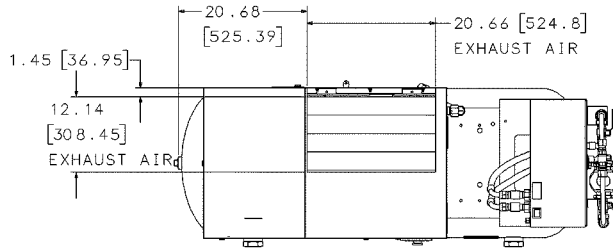
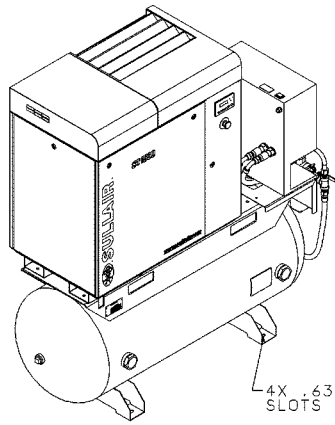

02250180-090 R00



02250179-437 R01

**Identification - ST1100, ST1500, 15-20HP Tank Mount with Dryer**

SEE TABLE NOTES:	
1. ALLOW 4.00 FEET [1.25 METERS] MINIMUM CLEARANCE AROUND MACHINE FOR ACCESS AND FREE CIRCULATION OF AIR.	
2. A FOUNDATION OR MOUNTING CAPABLE OF SUPPORTING THE WEIGHT OF PACKAGE, AND RIGID ENOUGH TO MAINTAIN THE COMPRESSOR FRAME LEVEL IS REQUIRED.	
3. ALL DIMENSIONS ARE +/- .50" [12.7MM]	
4. RECOMMENDED INCOMING CUSTOMER POWER SUPPLY IS SHOWN ON DRAWING.	
5. DOORS ARE REMOVABLE USING LIFT-OFF PINS.	
6. ALL DIMENSIONS SHOWN IN INCHES WITH MILLIMETER DIMENSIONS IN BRACKETS.	
A1: EXHAUST AIR OUT	
A2: AIR INLET	
A3: INCOMING CUSTOMER POWER SUPPLY 1.96[50]DIA	
A4: AIR OUT CONNECTION 3/4"NPT	
A5: SERIAL PLATE	
A6: HAND HOLD	
A7: CONTAINMENT PAN DRAIN 1/4"NPT	
A8: E-STOP	
A9: CONTROLLER	
A10: TANK MOUNT SERIAL PLATE	
A11: TANK DRAIN 1/4"NPT	
MACHINE WEIGHTS	
ST1100	1288LBS[584KG]
ST1500	1321LBS[599KG]

Figure 3-14: Wiring Diagram - SRS 25-100 115-230V/1/60

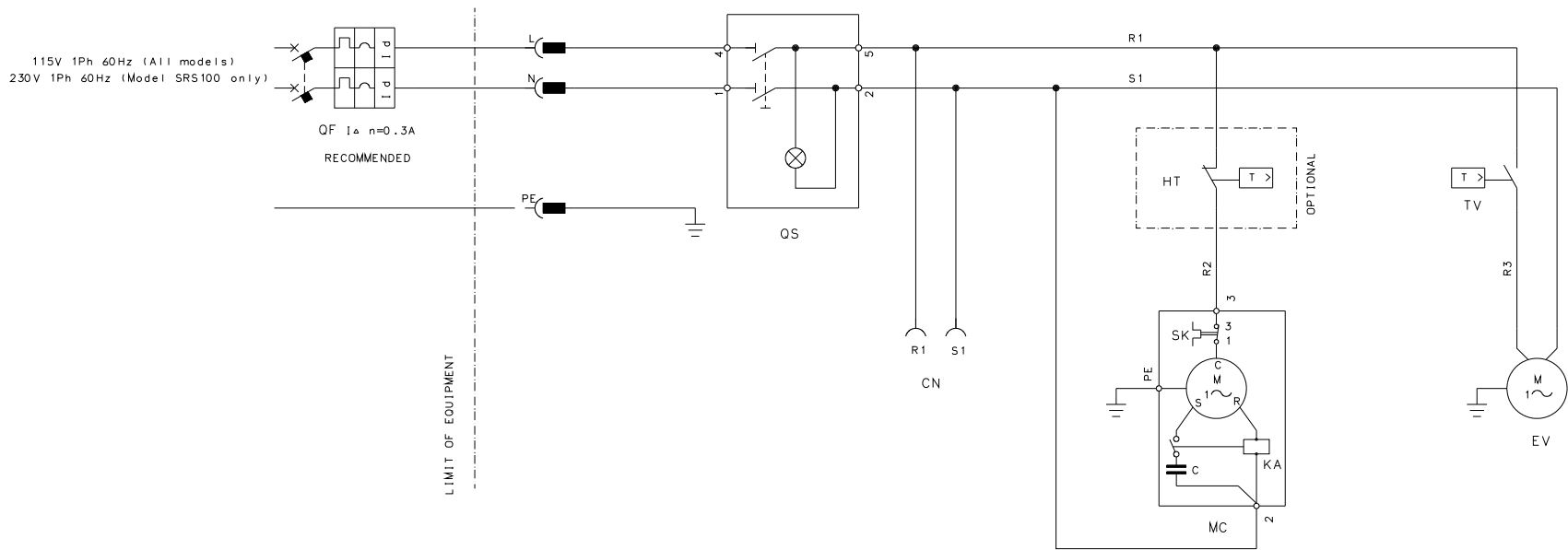

ELECTRICAL SPECIFICATIONS

COMPRESSOR - Un 115V 1Ph 60Hz		FAN MOTOR - Un 115V 1Ph 50-60Hz	
SRS-25	FLA 4.32 0.414kW	FLA 0.46	0.035kW
SRS-35	FLA 4.32 0.414kW	FLA 0.46	0.035kW
SRS-50	FLA 7.31 0.651kW	FLA 1.00	0.076kW
SRS-75	FLA 9.23 0.809kW	FLA 1.00	0.076kW
SRS-100	FLA 11.44 1.082kW	FLA 1.00	0.076kW
COMPRESSOR - Un 230V 1Ph 60Hz		FAN MOTOR - Un 230V 1Ph 50-60Hz	
SRS-100	FLA 5.72 1.082kW	FLA 0.50	0.076kW

COMPONENTS DESCRIPTION -

- QS MAIN SWITCH
- CN ELECTRONIC DRAIN POWER SUPPLY
- MC COMPRESSOR MOTOR
- EV FAN MOTOR
- SK COMPRESSOR OVERLOAD PROTECTOR
- KA STARTING RELAY
- C COMPRESSOR START CAPACITOR
- TV FAN THERMOSTATIC SWITCH
- HT HIGH TEMPERATURE SAFETY SWITCH

BY INSTALLER -

- OF RESIDUAL CURRENT AUTOMATIC CIRCUIT BREAKER

ELECTRICAL SUPPLY LINE 1 PHASE + NEUTRAL + PROTECTION EARTH
CABLES SIZE 3G16AWG

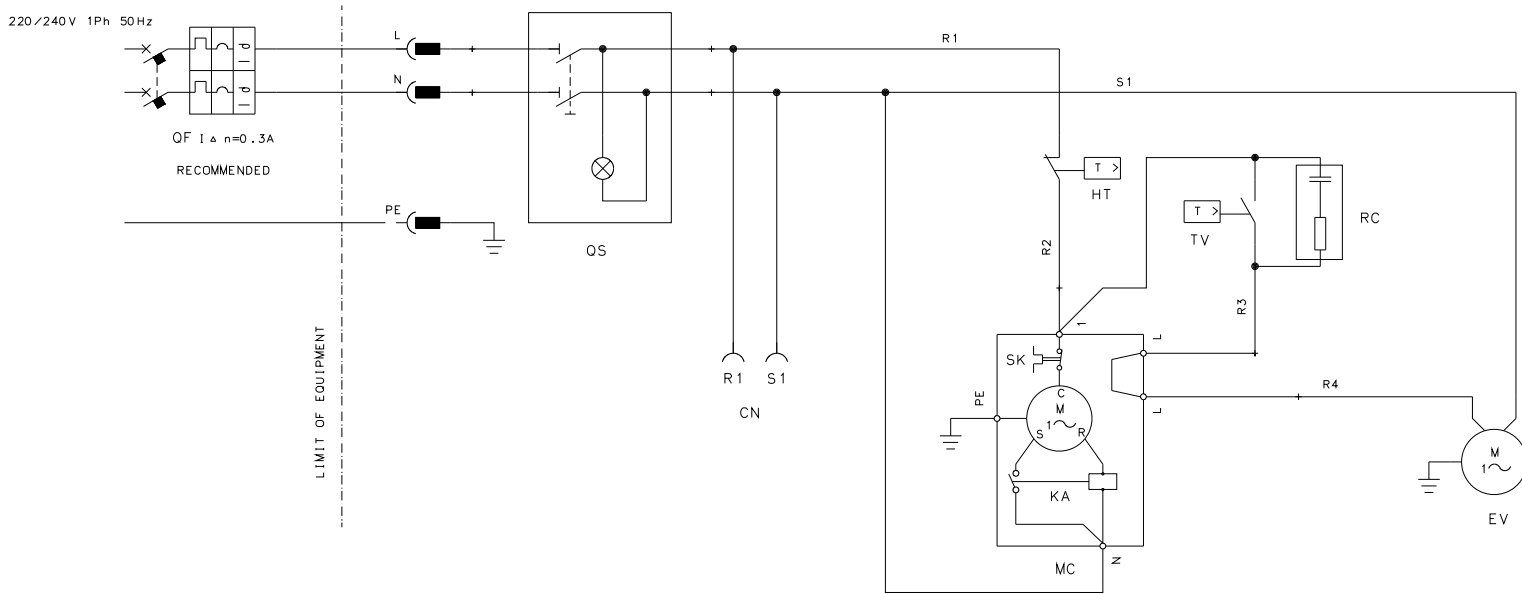

**Figure 3-15: Wiring Diagram - SRS 9-18 220-240V/1/50**

**ELECTRICAL SPECIFICATIONS**

COMPRESSOR Un 220/240V 1Ph 50Hz	FAN MOTOR Un 220/240V 1Ph 50-60Hz
SRS-9 FLA 1.70 0.325kW	FLA 0.16 0.029kW
SRS-12 FLA 2.05 0.355kW	FLA 0.16 0.029kW
SRS-18 FLA 3.20 0.550kW	FLA 0.23 0.035kW

BY INSTALLER

 OF RESIDUAL CURRENT AUTOMATIC  
CIRCUIT BREAKER

ELECTRICAL SUPPLY LINE 1 FASE + NEUTRO + PE
CABLES SIZE 3 G 1.5 mmq

**COMPONENTS DESCRIPTION**

- OS MAIN SWITCH
- CN ELECTRONIC DRAIN POWER SUPPLY
- MC COMPRESSOR MOTOR
- EV FAN MOTOR
- TV FAN THERMOSTATIC SWITCH
- RC SPIKES SUPPRESSION FILTER
- SK COMPRESSOR OVERLOAD PROTECTOR
- KA STARTING RELAY
- HT HIGH TEMPERATURE SAFETY SWITCH

Figure 3-16: Wiring Diagram - SRS 24-30 220-240V/1/50

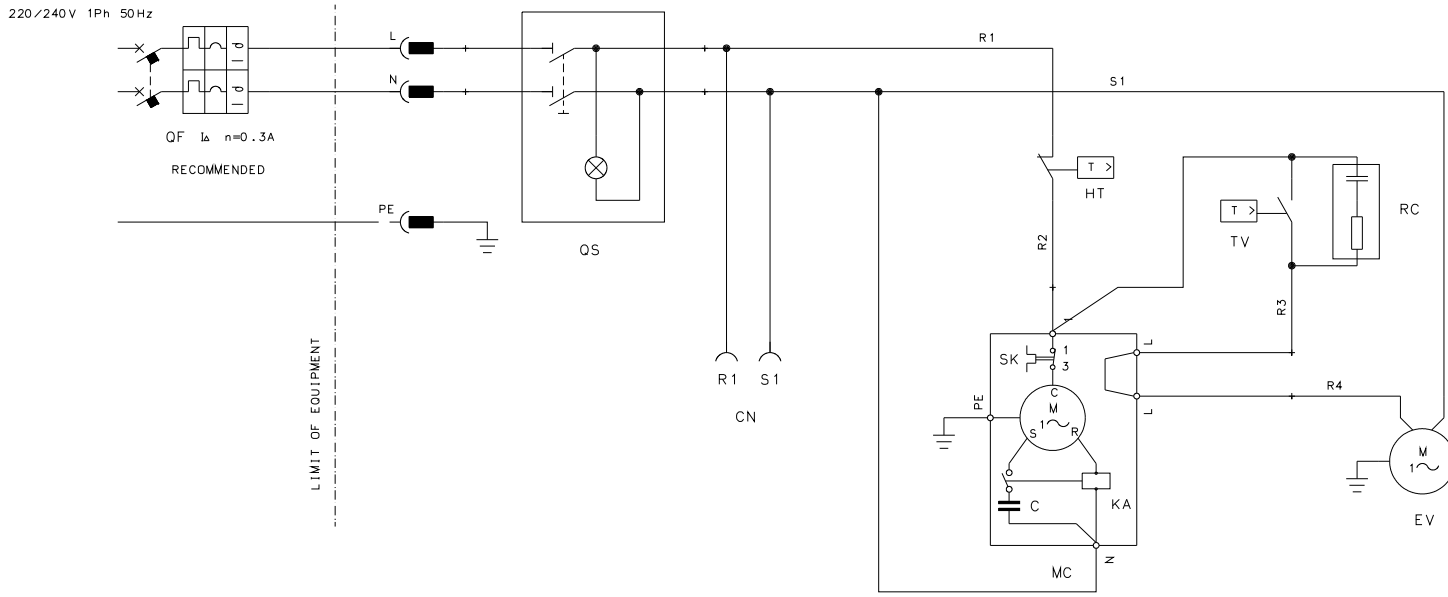

ELECTRICAL SPECIFICATIONS

COMPRESSOR	FAN MOTOR
Un 220/240V 1Ph 50Hz	Un 220/240V 1Ph 50-60Hz
SRS-30 FLA 4.80 0.880kW	FLA 0.23 0.035kW
SRS-24 FLA 4.16 0.721kW	FLA 0.23 0.035kW

BY INSTALLER

OF RESIDUAL CURRENT AUTOMATIC  
CIRCUIT BREAKER

ELECTRICAL SUPPLY LINE
1 FASE + NEUTRO + PE
CABLES SIZE
3 G 1.5 mmq

COMPONENTS DESCRIPTION

- QS MAIN SWITCH
- CN ELECTRONIC DRAIN POWER SUPPLY
- MC COMPRESSOR MOTOR
- EV FAN MOTOR
- TV FAN THERMOSTATIC SWITCH
- RC SPIKES SUPPRESSION FILTER
- SK COMPRESSOR OVERLOAD PROTECTOR
- KA STARTING RELAY
- C STARTING CAPACITOR
- HT HIGH TEMPERATURE SAFETY SWITCH

## Section 4

# INSTALLATION

---



---

### 4.1 COMPRESSOR MOUNTING - SUPPORT AND LOCATION

The compressor must have a stable firm foundation, or mounting structure that is rigid enough to keep the compressor frame level, and maintain the alignment of the compressor and motor. Tie-down bolts of sufficient size must be used to ensure that the compressor frame is firmly anchored to its foundation. Rubber, cork, or other pliable materials can be inserted between the foundation and compressor frame to provide a uniform contact surface.

- Use flex connectors to prevent piping loads from being transmitted to the compressor.
- National and local electrical codes specifying the required clearances for the area around the electrical panel must be complied with.
- Ensure the lighting at the compressor's location is sufficient for safe operation and maintenance.
- The compressor's location should be one that allows access for maintenance vehicles and lifting equipment.
- The clearances around the compressor should permit easy access to all compressor components.
- Walls and ceilings with soft or porous surfaces absorb sound and reduce ambient noise levels. Hard surfaces reflect noise and have little effect on ambient noise levels.

#### NOTE

**Do not install compressors where the machine will be exposed to temperatures lower than 32°F (0°C). Contact Sullair Customer Care regarding operation in sub-freezing temperatures.**

### 4.2 VENTILATION AND COOLING

- ShopTek compressors require a three foot (one meter) clearance around their perimeter.
- The location should be free from standing water.
- Clean air should be supplied to the compressor, free from exhaust and paint fumes, dust, metal particles, or caustic chemical vapors.
- Hot exhaust air should be vented out of the area to prevent its recirculation back into the compressor's cooling system.
- Ducting or some other means must be used to ensure that hot exhaust air is vented away from the compressor if the compressor's housing has minimal overhead clearance..

#### NOTE

**Remove the red shipping straps/shipping studs before operating the drive assembly. See *Figure 4-1* and *Figure 4-2*.**

#### NOTE

**Housing the compressor in an inadequately ventilated enclosure will cause higher compressor operating temperatures.**

Table 4-1: Ventilation Requirements		
Model	Ventilation Air Required	
	cfm	m <sup>3</sup> /hr
ST400	612	1040
ST500	612	1040
ST700	612	1040
ST1100	1471	2500
ST1500	1471	2500

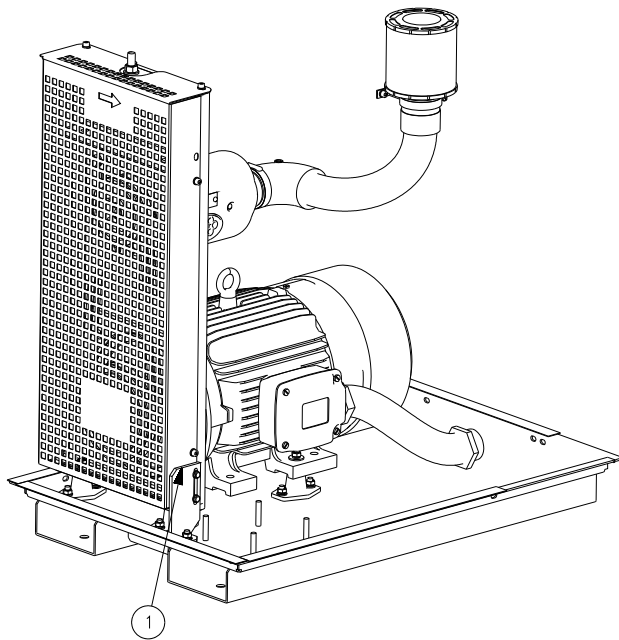

**Figure 4-1: ST400, ST500, ST700 Shipping Strap**

1. Shipping Strap

**OUTDOOR INSTALLATION (SHELTERED)**

ShopTek packages are equipped with TEFC motors and have water tight controls that are NEMA 4 rated and are suitable for sheltered outdoor installation.

The compressor should be mounted on a concrete pad. If the pad is not level, the compressor must be mounted in such a manner that its base or skid is level in relation to the pad's surface and fully supported.

If the compressor will be exposed to blowing rain or snow, it should be housed in a covered, four-walled enclosure.

- Sheltered air-cooled machines must have their exhaust air vented outside of the enclosure.
- Installations consisting of more than one compressor should be done in such a manner that each compressor's exhaust is directed away from the air intakes of other compressors or air dryers.
- A standard compressor should not be started if the ambient temperature is 35°F (1.7°C) or lower.

**Compressor must not be operated in sub-freezing conditions.**

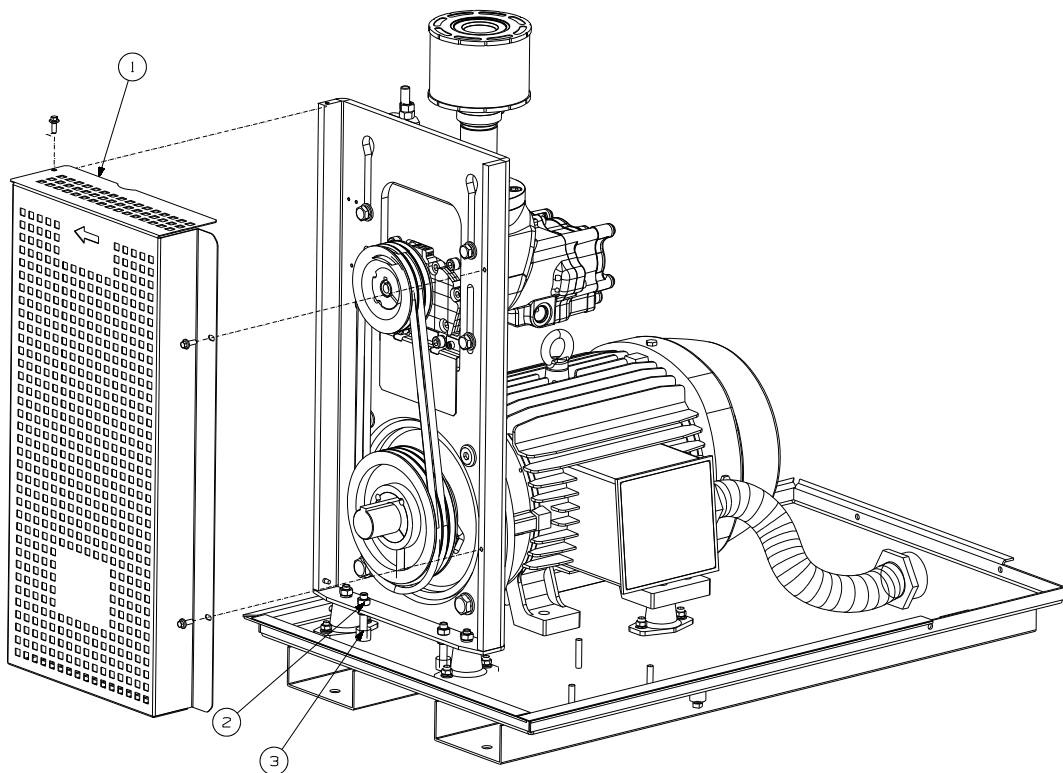

**Figure 4-2: ST1100, ST1500 Shipping Studs**

1. Belt Guard	3. Shipping Studs (2)
2. Nut (2)	

### 4.3 SERVICE AIR PIPING

Before installing the compressor, review the service air system's layout including: pipe sizes, auxiliary separator tube, drip legs, line filter(s), and isolation valves (See *Figure 4-3*).

#### NOTE

Systems using both reciprocating and rotary screw compressors must isolate the two types from each other through the use of a common receiver tank. Air lines from each individual compressor should be connected directly to the common receiver tank.

### PIPE SIZING

Pipes should be sized as a minimum to match the dimensions of the compressor's discharge connection. All piping and fittings should be rated for the discharge pressure.

### AUXILIARY RECEIVER TANK

An auxiliary receiver tank should be installed in systems where large demand fluctuations will occur.

**ISOLATION VALVES**

Install isolation valves where isolation of the compressor from the service lines is required. These valves should have drip legs that drain at an angle downward from the base. A vent to the piping should be installed downstream of the compressor outlet connection.

When two compressors are installed to operate in parallel with a common receiver tank, an isolation valve and drain trap for each compressor should be installed before the common separator/sump.

**NOTE**

**Compressors not equipped with a receiver tank may need to have their response times adjusted. Contact Sullair Customer Care for assistance.**

**FLUID CONTAINMENT**

Compressors have a fluid containment pan to collect fluid leaks or spills. The pan has a drain located on the front side of the machine.

**4.4 BELT CHECK**

Tension of drive belts should be checked upon installation and after 0.5 to 2 hours of run time. This is essential to proper performance of the compressor unit as well as to ensure long belt life. In addition, belt tension should be checked every 2000 hours and adjusted if necessary.

Refer to *Section 6: Belt Maintenance* for detailed instructions.

**4.5 FLUID LEVEL CHECK**

The compressor is shipped fully charged with the proper amount of fluid. However, it is necessary to check the fluid level at the time of installation and

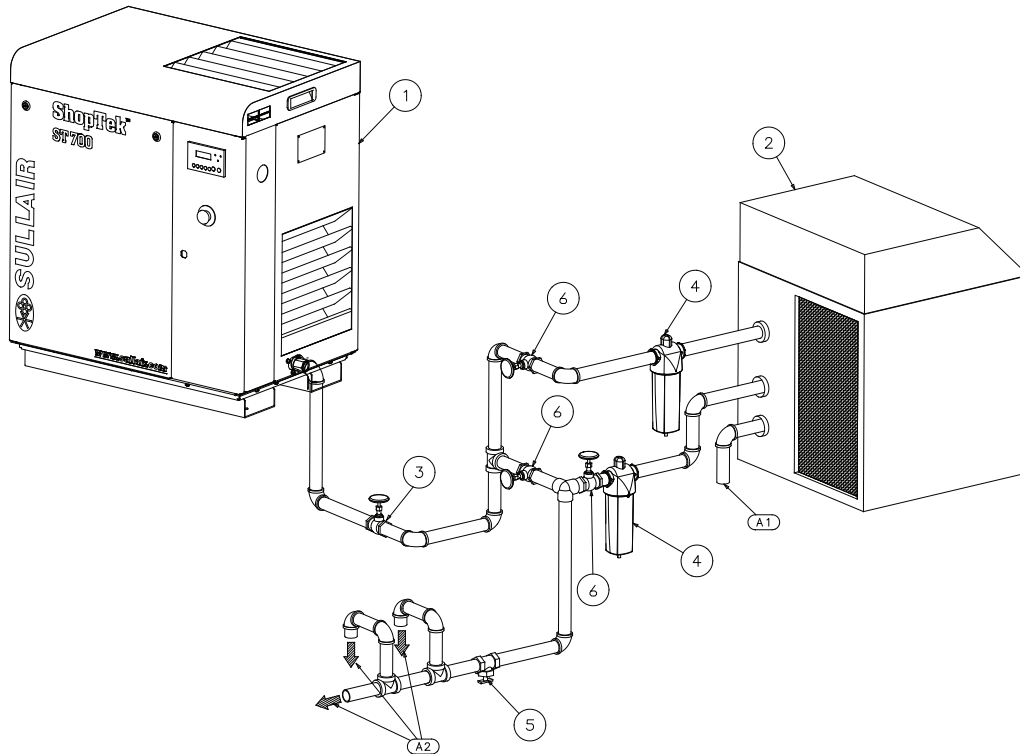

**Figure 4-3: Typical Service Air Piping**

1. Sullair Compressor	5. Standard Gate Valve
2. Sullair Dryer	6. By-pass Gate Valve
3. Shut-off Gate Valve	A1: Condensate Drain
4. Sullair Filter	A2: Air Outlets

during compressor operation. Check the fluid level by looking at the sight glass on the separator tube when the compressor is in the SHUT DOWN MODE (fluid level may not be visible when operating). In this condition the sight glass should be completely full. Add fluid if the level is visible or if no fluid is visible at all.

## 4.6 ELECTRICAL PREPARATION

Interior electrical wiring is installed at the factory. Required customer wiring should be done by a qualified electrician in compliance with OSHA, National Electric Code and/or any applicable local electrical codes applying to isolation switches, fused disconnects, etc. Refer to *Figure 3-2* and *Figure 3-4*. Sullair provides a wiring diagram for use by the installer. An electrical check should be made to ensure that the first start-up will be successful. The compressor and drive should be properly grounded/earthed in accordance with applicable codes, regulations, and requirements.

Feeder cables should be sized by the customer/ electrical contractor to ensure that the circuit is balanced and not overloaded by other electrical equipment. The length of wiring from a suitable electrical power source is critical because voltage drops can adversely effect the performance of the compressor. Cable sizes may vary considerably so the mains terminals will accept up to 120 mm<sup>2</sup> (4/0 awg) (75kw) cable.

Feeder cable connections to incoming terminals L1-L2-L3 should be tight and clean.

The applied voltage must conform to the motor and compressor data plate ratings.

A starter hole is provided for an incoming power connection. If it is necessary to make a hole in the control box in a different location, care should be taken to not allow metal shavings to enter the starter and other electrical components within the box. If another hole is used, the original hole must be blocked off with a sealed plug.



## WARNING

**Energized internal components are a potentially FATAL SHOCK HAZARD. Disconnect all power before performing any work on the compressor's electrical system.**

1. Check incoming voltage. The incoming voltage must match the compressor's wire rating/specifications.
2. Check motor starter and overload heater sizes.
3. Check all electrical connections for tightness.

## 4.7 MOTOR ROTATION DIRECTION CHECK

Motor rotation check must be done at compressor start-up after the wiring has been installed. See *Figure 4-4* and *Figure 4-5*. The compressor can be damaged if it runs in the wrong direction for more than a few seconds. Motor rotation can be viewed through the openings in the belt guard. Pull out the EMERGENCY STOP button and press once, quickly and in succession, the Ⓜ (START) pad and Ⓜ (STOP) pad. This action will bump start the motor. When looking at the motor from the compressor unit, the shaft should turn clockwise for ST400, ST500 and ST700 and counterclockwise for ST1100 and ST1500. If reverse rotation occurs, disconnect the power to the starter and exchange any two of the three power input leads, then re-check rotation. A "Direction of Rotation" decal is located on the motor drive housing to show proper motor/compressor rotation.

Fan motor rotation should also be checked. It should rotate counter-clockwise when viewing the fan motor from the backside of the motor.

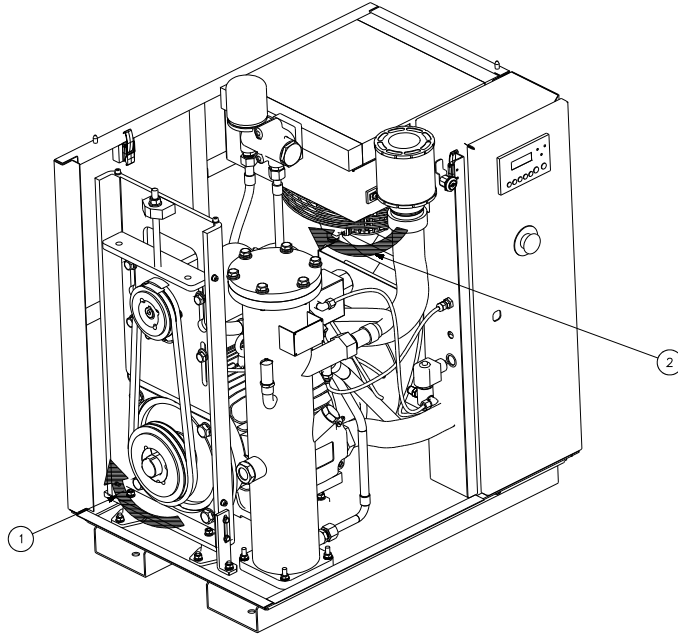

**Figure 4-4: Fan Motor/Main Motor Rotational Direction ST400, ST500, ST700, 5-10HP**

1. Main Motor Rotational Direction	2. Fan Motor Rotational Direction
------------------------------------	-----------------------------------

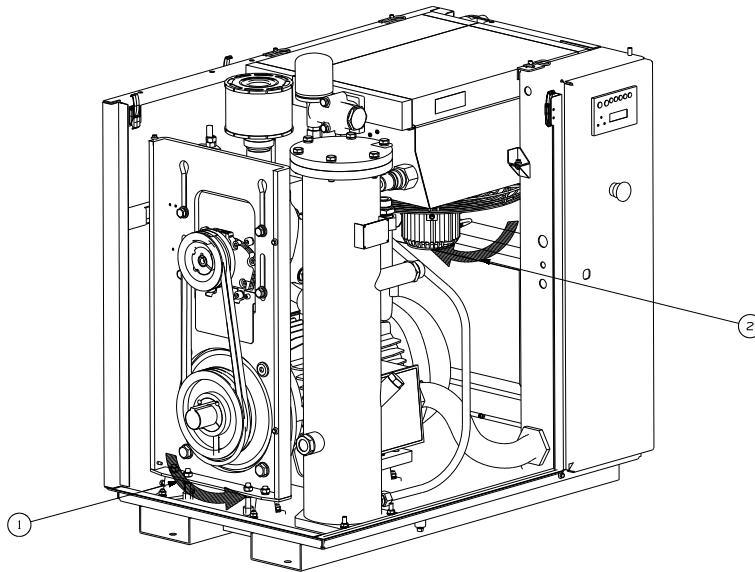

**Figure 4-5: Fan Motor/Main Motor Rotational Direction ST1100, ST1500, 15-20HP**

1. Main Motor Rotational Direction	2. Fan Motor Rotational Direction
------------------------------------	-----------------------------------



## Section 5

# OPERATION

---

---

### 5.1 ROUTINE OPERATION

Before starting the compressor, check the fluid level in the separator tube. If sight glass is not completely full, add the required amount of fluid to bring it to its proper level. Frequent addition of fluid indicates the presence of a leak or a condition causing excessive fluid consumption. See the *Troubleshooting – Introduction* on page 66 under EXCESSIVE COMPRESSOR FLUID CONSUMPTION for a probable cause and corrective action.

After a routine start, observe the controller display for the proper indications for this phase of operation. After the compressor has warmed up, check all compressor operation indications to ensure that it is running properly.



### WARNING

**HIGH-PRESSURE HAZARD!**  
**DO NOT** remove caps, plugs, and/or other components when compressor is running or pressurized. Stop compressor and relieve all internal pressure before doing so. Failure to comply could result in death or serious injury.

# NOTES

---

## Section 6

# MAINTENANCE

---



---

WARNING

Before any repairs are attempted, refer to *Section 1: Safety* before proceeding.

### 6.1 GENERAL

This compressor requires a minimal amount of inspections and maintenance. The Controller and other indicators alert the operator to situations requiring maintenance, or fault conditions.

### 6.2 MAINTENANCE AFTER INITIAL 50 HOURS OF OPERATION

After the initial 50 hours of operation, maintenance is required to clean the system of any foreign materials.

At this time the return line strainer should be cleaned. Refer to *Figure 6-1* and *Figure 6-2*.

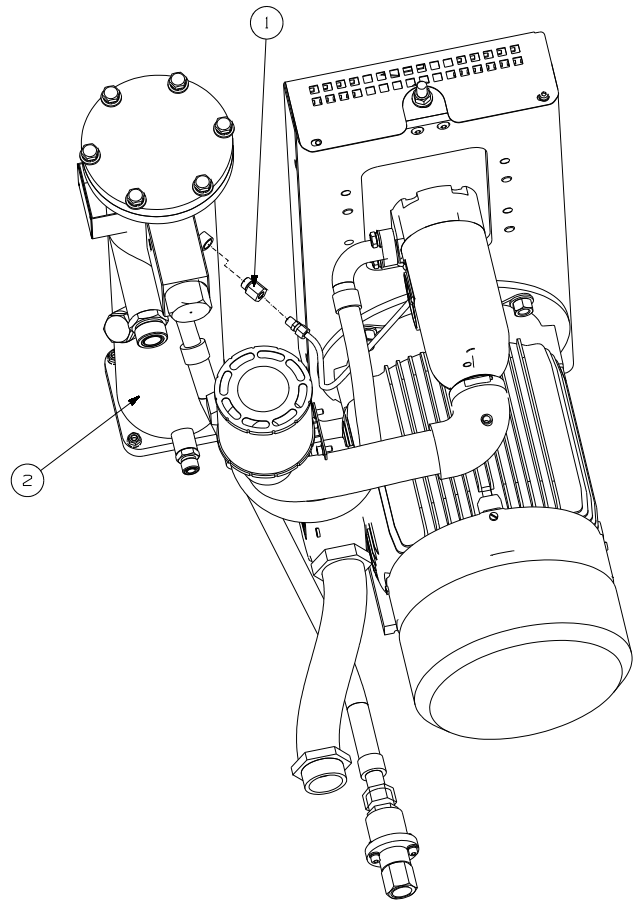

**Figure 6-1: Return Line Strainer  
ST400, ST500, ST700, 5-10HP**

- |    |                |
|----|----------------|
| 1. | Strainer       |
| 2. | Separator Tube |

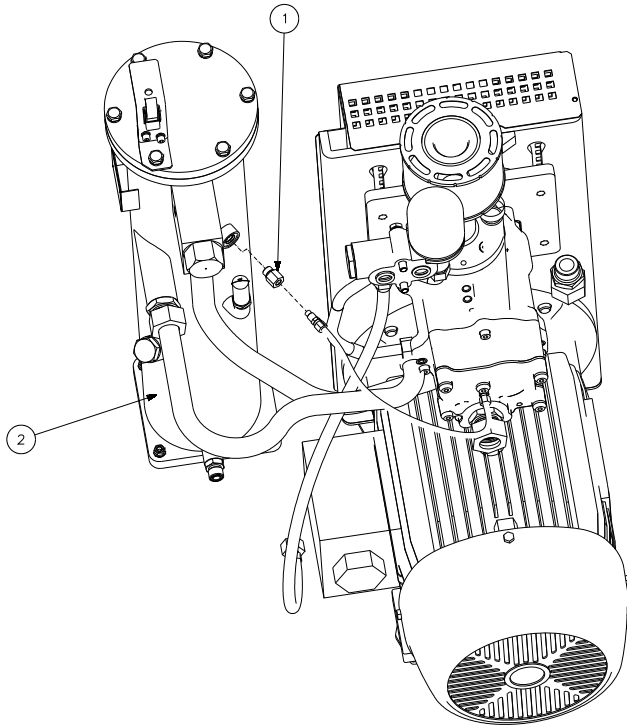

**Figure 6-2: Return Line Strainer  
ST1100, ST1500, 15-20HP**

1. Strainer
2. Separator Tube

### 6.3 MAINTENANCE EVERY 2000 HOURS

After 2000 hours of operation:

1. Clean the return line strainer. Refer to *Figure 6-1* and *Figure 6-2*.
2. Replace the fluid filter. Refer to *Figure 6-3* and *Section 6.5*.
3. Pull fluid sample for analysis.
4. Replace air filter. Refer to *Figure 6-4* and *Figure 6-5* and *Section 6.6*.
5. Check belt tension. Re-tension or replace as necessary. Refer to *Section 6.8*.

### 6.4 FLUID MAINTENANCE

Drain the separator tube and change the compressor fluid using instructions shown in the Lubrication Guide.

### 6.5 FILTER MAINTENANCE

Refer to *Figure 6-3*. Replace the fluid filter under any of the following conditions, or whichever occurs first:

1. Every 2000 hours a display on the Controller indicates the need for replacement
2. Every fluid change.

#### FLUID FILTER REPLACEMENT

Refer to *Figure 6-3*.

1. Use a strap wrench to remove the filter and gasket.
2. Dispose of filter properly.
3. Clean gasket seating surface.
4. Apply a light film of fluid to the filter gasket.
5. Hand tighten until gasket is seated.
6. Continue tightening filter an additional 1/2 to 3/4 turn.
7. Replace any lost fluid. Do not overfill.
8. Restart compressor and check for leaks.

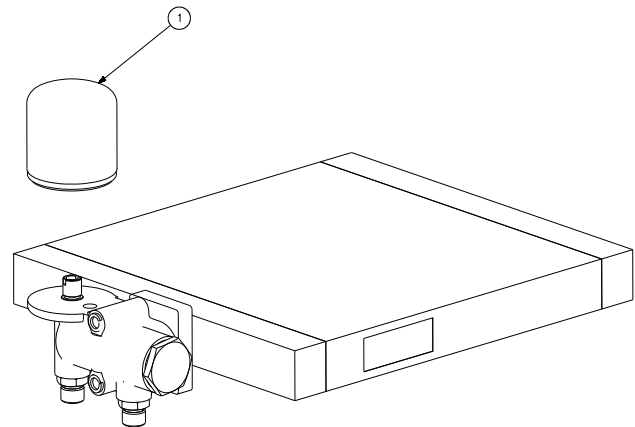

**Figure 6-3: Fluid Filter Assembly**

1. Fluid Filter
-----------------

### NOTE

**Dispose of fluids in accordance with applicable federal, state and local regulations.**

## 6.6 AIR FILTER MAINTENANCE

Refer to *Figure 6-4* and *Figure 6-5*. Air filter maintenance should be performed every 2000 hours or sooner if necessary.

### AIR FILTER ELEMENT REPLACEMENT

1. Remove enclosure panels to gain access to filter.
2. Loosen hose clamp and remove filter.
3. Install new filter and tighten hose clamp.

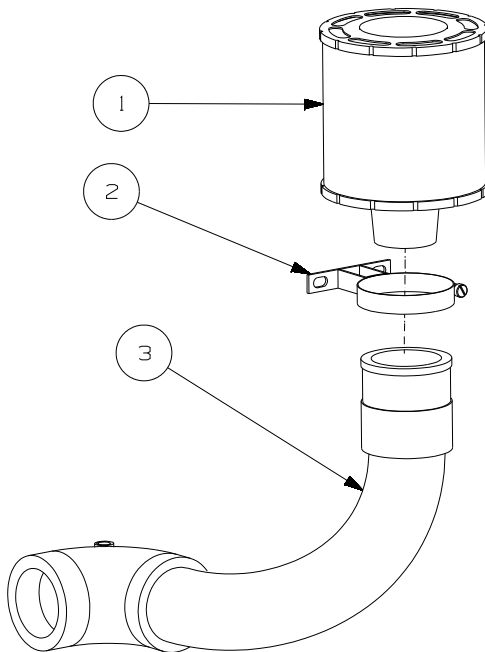

**Figure 6-4: Air Filter Assembly 5-10HP**

1. Air Filter Element
2. Clamp
3. Hose

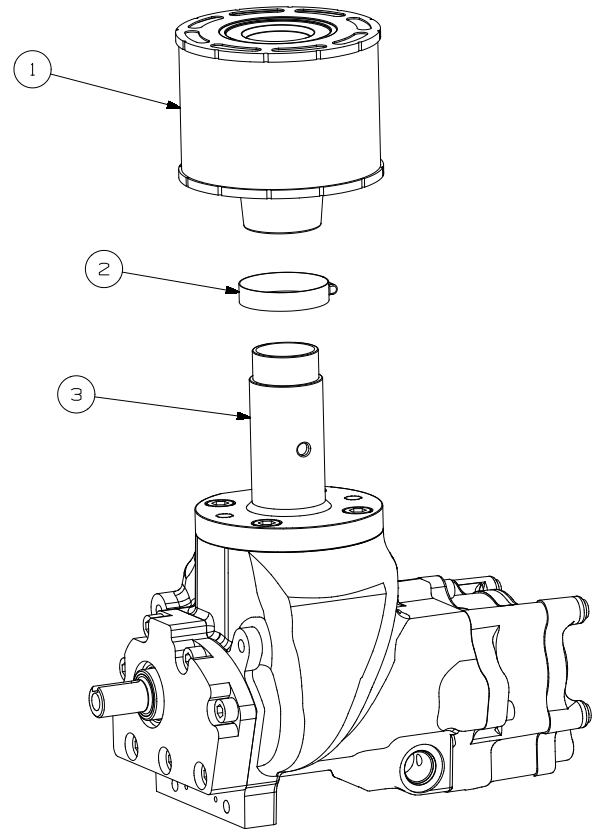

**Figure 6-5: Air Filter Assembly 15-20HP**

1. Air Filter Element
2. Clamp
3. Hose

### 6.7 SEPARATOR MAINTENANCE

Replace the separator elements every 2 years or 4000 hours, whichever occurs first. The separator elements must be replaced. **DO NOT** attempt to clean and reinstall the separator elements.

#### SEPARATOR ELEMENT REPLACEMENT

Refer to *Figure 6-6*. Use the following procedure below to change the separator:

CAUTION

**Relieve all pressure from the separator/ sump tank and all compressor lines.**

1. Loosen and remove the six (6) hex head capscrews (M12 x 45mm) from the cover plate.
2. Lift the cover plate from the separator tube.
3. Remove the separator element.
4. Inspect the separator tube for rust, contamination, or damage.
5. Reinsert the separator elements into the separator tube taking care not to dent the element against the tank opening.
6. Install a new lubricated O-ring in the O-ring groove on the underside of the separator/ tube cover.
7. Replace the cover plate, washers and capscrews. Torque to 28 ft-lbs. (38 N·m).
8. Clean the return line strainer before restarting the compressor. Refer to *Figure 6-1* and *Figure 6-2*.
9. Check condition of grounding spring on lid, ensure it is clean and provides good contact.

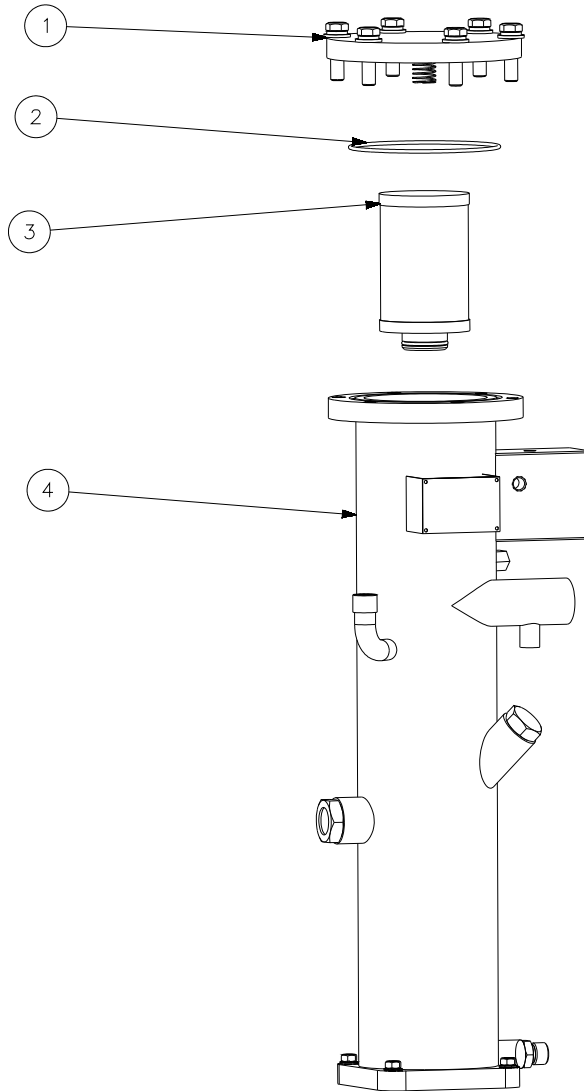

**Figure 6-6: Separator Element Assembly  
5-10HP**

1. Cover
2. Cover Gasket
3. Separator Element
4. Separator Tube

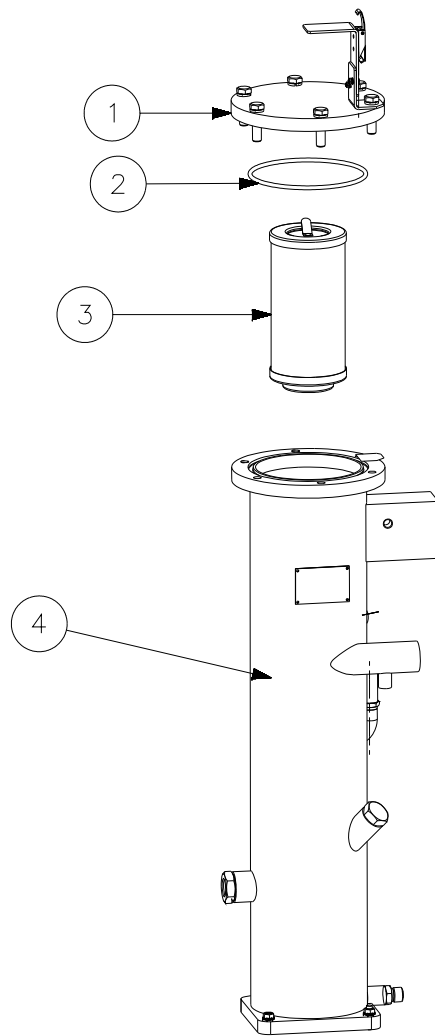

**Figure 6-7: Separator Element Assembly  
15-20HP**

1.	Cover
2.	Cover Gasket
3.	Separator Element
4.	Separator Tube

## 6.8 BELT MAINTENANCE

The correct drive belt tension is essential to ensure that full motor power is transmitted to the compressor unit. The belt tension is achieved by raising the compressor unit which has the effect of increasing belt tension. Refer to *Figure 6-10* and *Figure 6-11*.

Belt tension must be re-adjusted 0.5 to 2 hours after a new set of belts are fitted. This will ensure that the belts have completed their initial stretch. Subsequent to this, belt tension needs to be checked and adjusted if necessary every 2000 hours for the duration of the belt life.

There are two recommended methods for checking the belt tension. The test methods will be detailed as follows.

### BELT TENSION MEASUREMENT WITH OPTIKRIK TENSION METER.

Refer to *Figure 6-8*. Follow instructions as follows:

- A. Ensure the indicator arm is pushed down prior to starting.
- B. Gently place the meter on the flat side of one belt at the midpoint between the motor and compressor unit pulleys.
- C. Slowly press on the push pad. Avoid contacting the meter with other fingers as this may affect the reading.
- D. Once a definite click is detected, immediately release pressure and the indication arm will remain in the measuring position.
- E. Carefully lift the meter without moving indicating arm.
- F. Read the measurement at the exact point where the top surface of the indicator arm crosses the scale.
- G. Rotate the motor pulley through at least one complete revolution and measure the tension again, recording the results.
- H. Repeat G for a total of 3 measurements.
- I. Average the three measurements to obtain the true belt tension.
- J. Repeat for remaining belts.
- K. Compare the results to the belt tension specification in Table 6-1 and adjust if necessary.

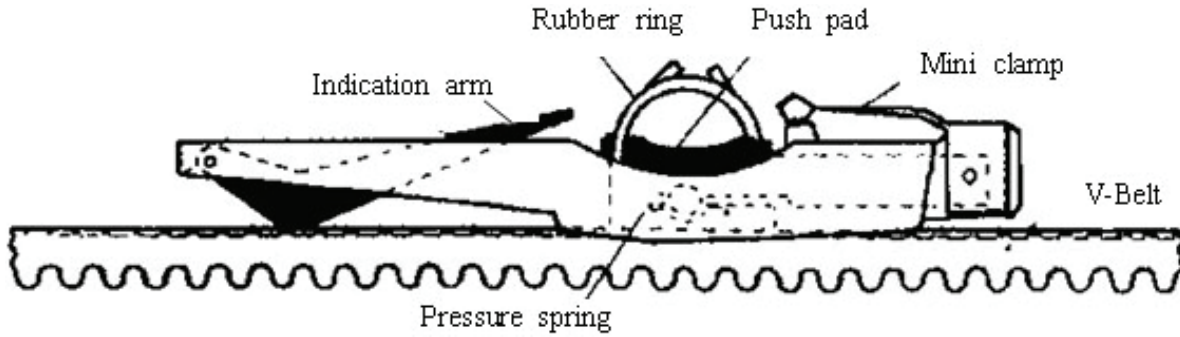

Figure 6-8: Optikrik Belt Tension Meter

**BELT TENSION MEASUREMENT WITH FREQUENCY METER**

Refer to *Figure 6-9*. Follow instructions as follows:

- A. Turn on the meter.
- B. Hold the meter so that the probe is >10mm (3/8") away from the belt being tested. Do not touch the belt with tester probe.
- C. Pluck a single belt at the midpoint between the motor and compressor unit pulleys. Try not to disturb any adjacent belts, as this will give a false reading. As the probe detects a vibration, the meter will display the frequency. Record data.
- D. Rotate the motor pulley through at least one complete revolution and measure the belts again, recording the results.
- E. Repeat D for a total of 3 measurements.
- F. Average the three measurements to obtain the true belt tension.

G. Repeat for remaining belts.

H. Compare the results to the belt tension specification in *Table 6-1* and adjust if necessary.



Figure 6-9: Belt Tension Frequency Meter



Table 6-1: Belt Tension Requirements

Model	HP	Hz	TT Mini		Optikrik	
			First Time	Re-tension	First Time	Re-tension
			Frequency (Hz)	Frequency (Hz)	Force (N)	Force (N)
<b>ST400 Series</b>						
ST410	5	60	80	70	233	180
ST410	5	50	82	72	232	178
<b>ST500 Series</b>						
ST510	7.5	60	78	68	214	165
ST510	7.5	50	84	74	215	165
<b>ST700 Series</b>						
ST709	10	60	87	76	250	192
ST712	10	60	81	71	242	186
ST708	10	50	90	79	237	182
ST713	10	50	85	79	230	191
<b>ST1100 Series</b>						
ST1109	15	60	85	75	245	189
ST1112	15	60	85	74	254	195
ST1108	15	50	92	81	248	191
ST1113	15	50	89	78	255	196
<b>ST1500 Series</b>						
ST1509	20	60	92	80	283	217
ST1512	20	60	101	88	276	212
ST1508	20	50	92	81	261	201
ST1513	20	50	91	80	274	210

## BELT TENSION ADJUSTMENT

Refer to *Figure 6-10* and *Figure 6-11*.

Adjust the belt tension according to the following procedure:

- A. Shut down the compressor and isolate all electric power.
- B. Open the side panel and remove belt guard.
- C. Loosen the locking nut.
- D. Loosen the four compressor unit mounting plate bolts  $\frac{3}{4}$  of a turn.
- E. Adjust the belt tension by turning the jacking nut clockwise to tighten or counterclockwise to loosen.
- F. Measure belt tension and ensure it meets the specifications in *Table 6-1*.
- G. Tighten the locking nut.
- H. Tighten the four compressor unit mounting plate adjusting bolts.
- I. Ensure that the discharge hose is not kinked, bent, or has been placed under undue stress or strain.
- J. Replace the belt guard and the side panel.

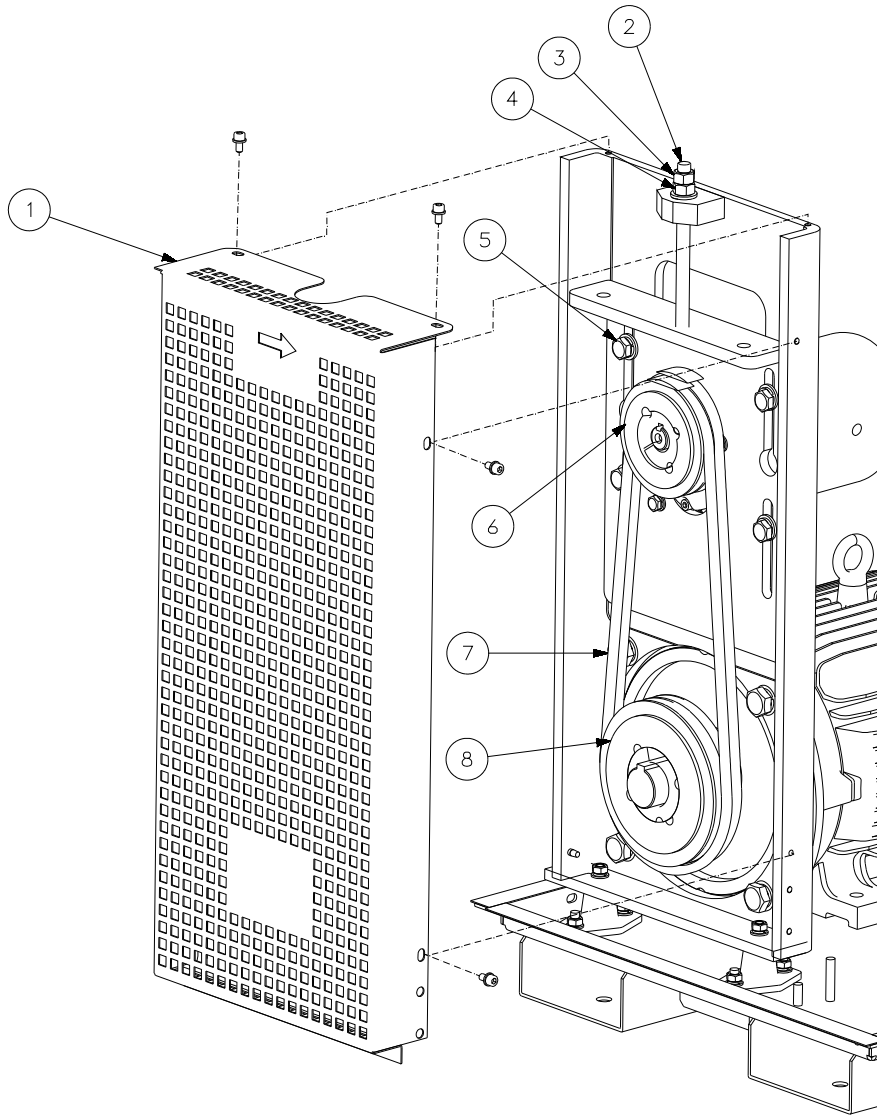

**Figure 6-10: Belt Tension Adjustment, ST400, ST500, ST700, 5-10HP**

1. Belt Guard	5. Comp. Unit Mounting Plate Bolts (4)
2. Belt Tension Adjustment Screw	6. Comp. Unit Pulley
3. Locking Nut	7. Belts
4. Jacking Nut	8. Motor Pulley

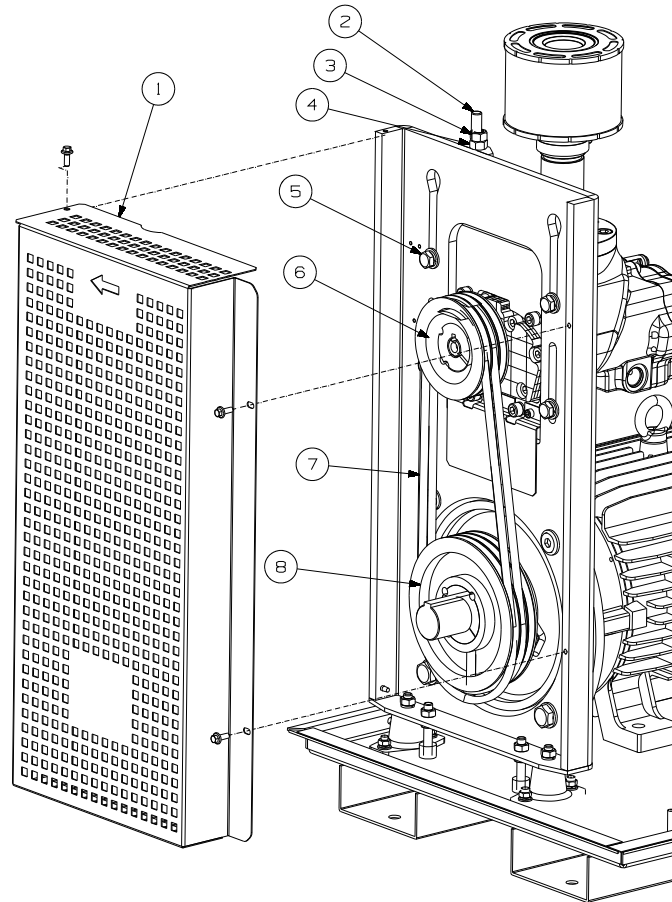

**Figure 6-11: Belt Tension Adjustment, ST1100, ST1500, 15-20HP**

1. Belt Guard	5. Comp. Unit Mounting Plate Bolts (4)
2. Belt Tension Adjustment Screw	6. Comp. Unit Pulley
3. Locking Nut	7. Belts
4. Jacking Nut	8. Motor Pulley

## 6.9 REPLACEMENT AND ALIGNMENT OF BELT PULLEYS

In the event of the motor or compressor unit having been removed and replaced, pulley alignment will have to be checked and adjusted.

Misalignment of pulleys can cause rapid wear of the V belt form, considerably shortening the service life of both belts and pulleys. Due to Sullair's innovative design, only parallel alignment of the drive pulleys needs to be checked

**PARALLEL ALIGNMENT CAN BE CHECKED BY TWO METHODS.**

1. Placing a straight edge against the pulleys near their centers. For correct alignment, the straight edge must be sitting flat against both pulleys, i.e. full face contact. There should be no more than 0.5mm misalignment.
2. Using a laser, ensure misalignment is no greater than 0.5°.

To correct parallel misalignment, first check that the rear face of the compressor unit pulley is positioned 0.3in (7.5mm) off the mounting face. This is required to ensure that the belts clear all mounting bolt heads. With the compressor unit pulley correctly positioned, move the motor pulley on the shaft to achieve correct alignment.

**INSTRUCTIONS FOR INSTALLING A PULLEY:**

1. Clean all surfaces of shaft, pulley and taper lock bushing.
2. Fit taper lock bushing inside pulley.
3. Spray oil or anti-seize compound on the grub screw threads and gently screw in.
4. Slide the pulley/bushing assembly on to the shaft to the correct position, aligning the keyway.
5. Tighten the grub screws in stages to the specification in *Table 6-2*.
6. Check pulley alignment.
7. Install belts and tension as outlined in the belt tensioning procedure.
8. Run machine for 0.5-1 hour and check the tightening torque of the grub screws. Tighten if necessary;

**INSTRUCTIONS FOR REMOVING A PULLEY:**

1. Loosen and remove both grub screws.
2. Install one grub screw into the jacking/disassembly hole. Refer to *Figure 6-12*.
3. Tighten grub screw to release taper lock hub from pulley.
4. Slide pulley and bushing from shaft.

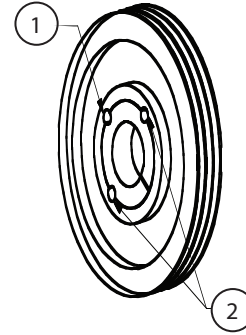

**Figure 6-12: Diagram of belt pulley and taper lock bushing assembly**

1. Jacking/Disassembly Hole
2. Installation Hole

**6.10 HOSE MAINTENANCE**

Fluid and air hose replacement is recommended after three (3) years or 16,000 hours of operation.

**6.11 TANK MOUNT PACKAGE MAINTENANCE**

Receiver tank should be drained daily. Change SCF filters when indicated by gauge on housing. Refer to dryer documentation for maintenance requirements.

**6.12 TROUBLESHOOTING – INTRODUCTION**

The information in the Troubleshooting Guide describe symptoms and usual causes for the listed discrepancies. However, **DO NOT** assume that these are the only malfunctions or fault conditions that may occur.

**NOTE**

**For additional troubleshooting guidelines, consult the Controller manual.**

*Table 6-2: Pulley Tightening Torque Specification*

Tapered Hub	Size of Hex Key (mm)	Number of Grub Screws	Tightening Torque	
			ft•lbs	N•m
1210/1610	5	2	14.8	20.0
2012	6	2	22.1	30.0

<i>Table 6-3: Troubleshooting Guide</i>		
<b>SYMPTOM</b>	<b>PROBABLE CAUSE</b>	<b>REMEDY</b>
Compressor will not start	Main disconnect switch open	Close switch.
	Line fuse blown	Replace fuse.
	Motor starter overload tripped	Reset - if fault persists, check motor contacts for proper function.
	Low incoming line voltage	Check voltage - in the case of low voltage, check power source, or contact local power company.
Compressor shuts down under service load conditions	Loss of control voltage	Check 110V AC power supply.
	Low incoming line voltage	Check voltage - in the case of low voltage, check power source, or contact local power company.
	High operating pressure	Reset - if fault persists, check line pressure and ensure that it does not exceed the compressor's maximum operating pressure.
Compressor shuts down under service load conditions - High Pressure Fault	Compressor pressure setting incorrect	Change setting in Controller.
	Control line strainer clogged	Clean or replace strainer.
	Minimum pressure valve malfunction	Repair or replace minimum pressure valve.
	Control line air leak	Repair leak
	Defective unload solenoid valve	Check valve – if it does not operate when energized, replace the valve coil or the entire valve if defective.
Compressor shuts down under service load conditions - High Temperature Fault	Cooling air flow restricted	Clean cooler and check for proper ventilation.
	Ambient temperature too high	Check ventilation and increase if too low.
	Low fluid level	Add fluid.
	Clogged fluid filter	Change the fluid filter element.
	Thermal valve malfunction	Replace thermal valve element.
	Temperature sensor RTD malfunction	Check connection and sensor – replace if sensor is defective.
	Cooling fan rotational direction is reversed.	Reconnect fan motor cables for proper rotational direction.

*Table 6-3: Troubleshooting Guide*

<b>SYMPTOM</b>	<b>PROBABLE CAUSE</b>	<b>REMEDY</b>
Compressor cannot produce full discharge pressure	Air demand too high	Check service lines for leaks or open valves.
	Dirty air filter	Replace filter.
	Inlet valve bleed orifice obstructed/plugged	Check the control line bleed orifice inside the inlet valve for blockage or obstructions.
	Defective unload solenoid valve	Check the valve - if it does not operate when energized, replace the valve coil or the entire valve if defective.
	Minimum pressure valve malfunction	Repair or replace minimum pressure valve
	Pressure sensor malfunction	Check connection and sensor – replace if sensor is defective.
	Belts slipping due to lack of tension	Ckeck belts. Re-tension or replace as necessary.
Line pressure rises above unload pressure set-point	Control system leak causing loss of pressure signals	Check for leaks.
	Inlet valve stuck open	Remove the intake hose and check the inlet valve for proper operation.
	Defective unload solenoid valve	Check the valve for proper operation - open when energized - replace if necessary
	Plugged/obstructed control line strainer	Clean or replace strainer
	Pressure sensor malfunction	Check connection and sensor – replace if sensor is defective.
High compressor fluid consumption	Clogged return line or orifice	Clean or replace the strainer.
	Separator element damaged or malfunctioning	Change separator.
	Lubrication system leak	Check all pipes, connections, and components.
	Excess fluid foaming	Drain fluid and change.
	Fluid level too high	Drain and change - check that the compressor temperature has not dropped below 170°F (76.7°C).
Pressure relief valve opens frequently	Pressure relief valve defective	Replace.
	Plugged/obstructed separator	Check separator differential.
	Pressure sensor malfunction	Check connection and sensor - replace if sensor is defective.





## WORLDWIDE SALES AND SERVICE

---

---

### **SULLAIR ASIA, LTD.**

Zuo Pao Tai Road, No. 1  
Chiwan, Shekou  
Shenzen, Guangdong PRV.  
PRC POST CODE 518068  
Telephone: 755-6851686  
Fax: 755-6853473  
[www.sullair-asia.com](http://www.sullair-asia.com)

### **SULLAIR CORPORATION**

3700 East Michigan Boulevard  
Michigan City, Indiana, 46360 U.S.A.  
[www.sullair.com](http://www.sullair.com)  
Telephone: 1-800-SULLAIR (U.S.A. only)  
Fax: 219-874-1273

### **CUSTOMER CARE for PARTS and Service**

1-888-SULLAIR (7855247)  
219-874-1835

### **SULLAIR EUROPE, S.A.**

Zone Des Granges BP 82  
42602 Montbrison, France  
Telephone: 33-477968470  
Fax: 33-477968499  
[www.sullaireurope.com](http://www.sullaireurope.com)

### **Champion Compressors, LTD.**

324-332 Frankston Dandenong Road  
Dandenong VIC  
Australia 3175  
Ph: +61397039000  
Fx: +61397039053  
[www.championcompressors.com.au](http://www.championcompressors.com.au)

**Printed in the U.S.A.**

Specifications subject to  
change without prior notice.  
E10EP