

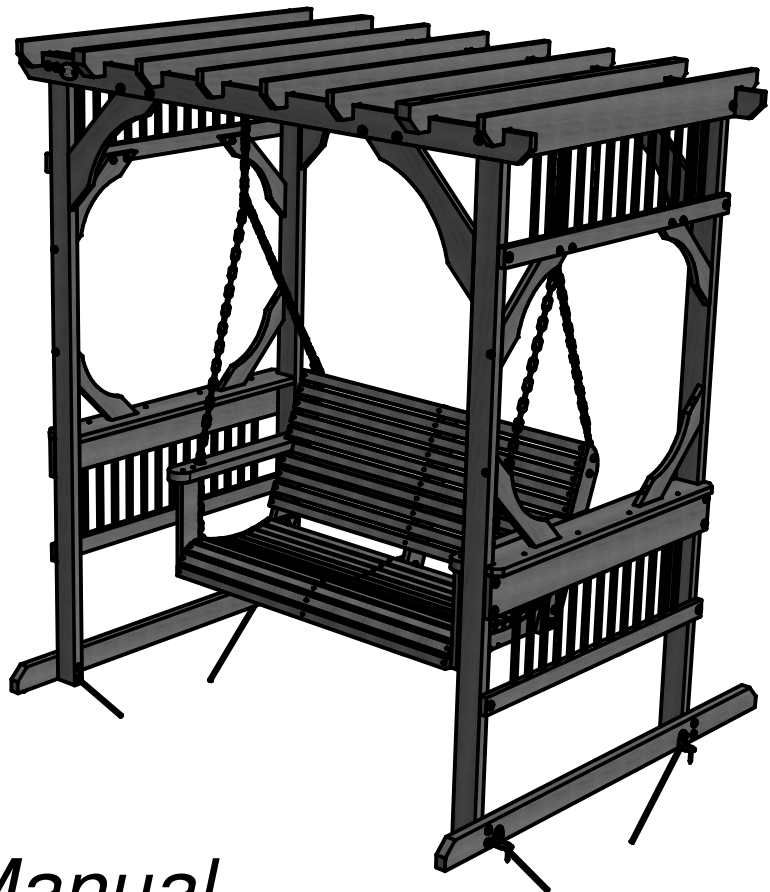

**DISCOVERY**

*Backyard Discovery  
3305 Airport Drive  
Pittsburg, KS 66762  
1-800-856-4445*

# DELUXE PERGOLA SWING OUTDOOR PRODUCT MODEL: #1606616



- *Owner's Manual*
- *Frequently Asked Questions*
- *Assembly Instructions*
- *Warranty Information*

*Register your new (Outdoor Product) on-line @  
[www.swingsetsonline.com](http://www.swingsetsonline.com) (you will also find any updates on  
assembly instructions and information to order replacement parts)*

*Features the **SAFE-I-FUSE** Patent Pending fastening system.*

*Save this assembly manual for future reference in the event that  
you need to order replacement parts.*

# STOP PARE

Missing A Part?

**CALL US BEFORE GOING  
BACK TO THE STORE!**

The store where you made your purchase  
does not stock parts for this item.

If you have assembly questions or if you need parts,  
whether they are missing or damaged

Call Toll-Free Help Line or visit [www.swingsetsonline.com](http://www.swingsetsonline.com)

**¡LLÁMENOS ANTES DE REGRESAR A LA TIENDA!**

La tienda donde realizó la compra no almacena piezas de este producto.

Si tiene preguntas sobre el ensamblaje o si necesita piezas debido a que  
faltan o están dañadas

llame gratis a la línea de ayuda

## 1-800-856-4445

### **PLEASE READ THIS BEFORE STARTING ASSEMBLY POR FAVOR LEA ESTAS INSTRUCCIONES ANTES DE COMENZAR EL ENSAMBLAJE**

- READ THE ASSEMBLY MANUAL COMPLETELY, PAYING SPECIAL ATTENTION TO THE IMPORTANT TIPS AND SAFETY INFORMATION.
- AFTER YOU HAVE READ THE ASSEMBLY MANUAL, YOU WILL BE ABLE TO DECIDE IF YOU NEED PROFESSIONAL HELP TO COMPLETE THE ASSEMBLY OF THE STRUCTURE.
- SEPARATE AND IDENTIFY ALL PARTS TO MAKE SURE THAT YOU HAVE ALL OF THE PARTS LISTED.
- IF YOU CAN'T FIND ALL OF THE PARTS, CHECK THE PACKING MATERIAL. SMALL PARTS MAY HAVE FALLEN INTO IT DURING SHIPMENT.
- IF YOU HAVE PROBLEMS WITH THE ASSEMBLY OR IF ANY PART IS MISSING OR DAMAGED, PLEASE CALL THE HELP LINE **1-800-856-4445 OR VISIT [www.swingsetsonline.com](http://www.swingsetsonline.com)**
- LEA EL MANUAL DE ENSAMBLAJE COMPLETAMENTE, PRESTANDO ESPECIAL ATENCIÓN A LOS CONSEJOS ÚTILES IMPORTANTES Y A LA INFORMACIÓN SOBRE SEGURIDAD.
- DESPUÉS DE QUE HAYA LEÍDO EL MANUAL DE ENSAMBLAJE, PODRÁ DECIDIR SI NECESITA AYUDA PROFESIONAL PARA EFECTUAR EL ENSAMBLAJE DE LA ESTRUCTURA.
- SEPARE E IDENTIFIQUE TODAS LAS PIEZAS PARA COMPROBAR QUE DISPONE DE TODAS LAS PARTES INDICADAS.
- SI NO PUEDE ENCONTRAR TODAS LAS PIEZAS, REVISE EL MATERIAL DE EMPAQUE. ES POSIBLE QUE ALGUNAS PIEZAS PEQUEÑAS PUEDAN HABERSE CAÍDO ALLÍ DURANTE EL ENVÍO.
- MANTÉNGASE ALEJADO DE LOS NIÑOS MENORES A LA EDAD RECOMENDADA.
- SI TIENE PROBLEMAS CON EL ENSAMBLAJE O SI ALGUNA PIEZA FALTA O ESTÁ DAÑADA, LLAME A LA LÍNEA DE AYUDA AL **1-800-856-4445 O VISITE [www.swingsetsonline.com](http://www.swingsetsonline.com)**

PLEASE HAVE THE FOLLOWING INFORMATION WHEN YOU MAKE YOUR CALL:

- 1 – MODEL NUMBER OF THE PRODUCT LOCATED ON THE FRONT OF THE ASSEMBLY MANUAL
- 2 – DESCRIPTION OF THE PART FROM THE PARTS LIST

POR FAVOR TENGA VISIBLE LA SIGUIENTE INFORMACIÓN CUANDO LLAME:

- 1 - NÚMERO DE MODELO DEL PRODUCTO QUE SE ENCUENTRA UBICADO AL FRENTE DEL MANUAL DE ENSAMBLAJE
- 2 - DESCRIPCIÓN DE LA PIEZA QUE SE ENCUENTRA EN LA LISTA DE PIEZAS

# Owner's Manual Outdoor Product

## Dear Customer:

Please read entire booklet completely before beginning the assembly process.

Structures are **not intended for public use**. The Company does not warranty any of its residential structures subjected to commercial use such as: Recreational Park, or any similar Commercial Application.

Please follow all recommendations below. **Failure to do so may result in the warranty being void and/or safety violations that could result in serious injury**. This manual contains helpful information concerning Assembly Preparation, Installation Procedure, and Required Maintenance. Always keep safety in mind as your structure is being built.

**PLEASE RETAIN THESE INSTRUCTIONS FOR FUTURE REFERENCE. KEEP THEM IN A SAFE PLACE WHERE YOU CAN REFER TO THEM AS NEEDED. IN ORDER TO PROVIDE YOU WITH THE MOST EFFICIENT SERVICE, IT IS REQUIRED THAT YOU PROVIDE US WITH THE PART NUMBERS WHEN ORDERING PARTS.**

### For Your Records:

*Please take time and fill out the information below. This information will be needed for warranty issues.*

Where Purchased: \_\_\_\_\_

Date of Purchase: \_\_\_\_\_

Installation Date: \_\_\_\_\_

Installed by: \_\_\_\_\_

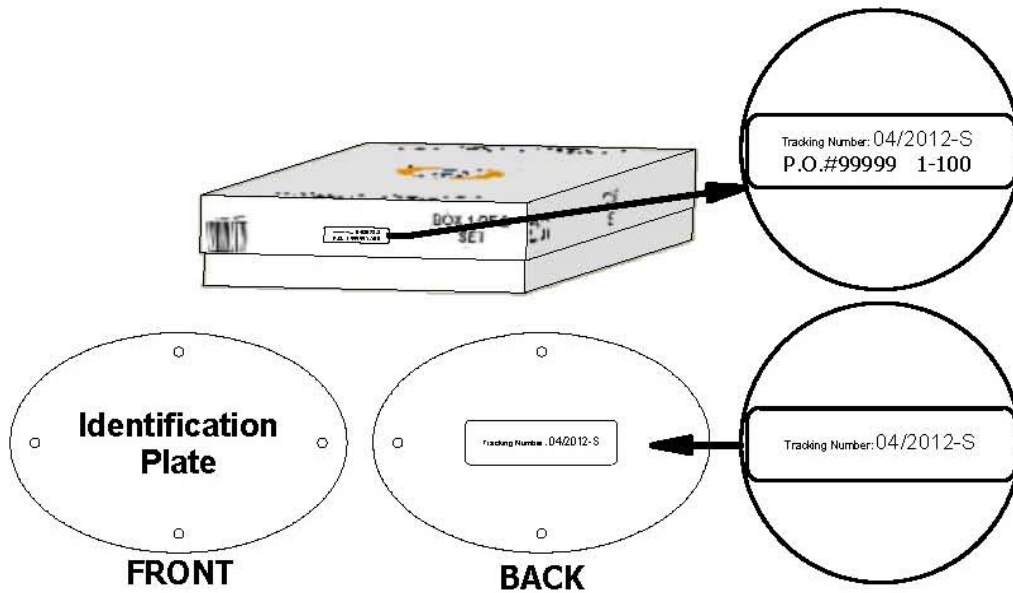
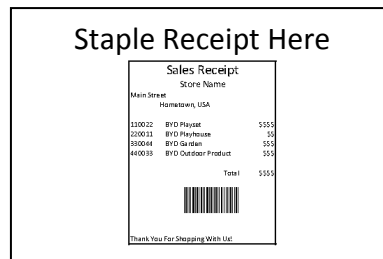

### **Tracking Number Reference Label**

*Tracking ID number on the carton and back of the ID plate are included for tracking purposes associated with warranty claims.*

# Owner's Manual Outdoor Product

---

## **Maintenance Instructions:**

1. Check all nuts and bolts twice monthly during the usage season and tighten as required. (But not so tight that you crack the wood) It is particularly important that this procedure be followed at the beginning of each season.
2. Oil all metallic moving parts monthly during the usage period.
3. Check all coverings for bolts and sharp edges twice monthly during usage season to be certain they are in place. Replace when necessary. It is especially important to do this at the beginning of each new season.
4. For rusted areas on metallic members such as hinges, brackets, etc. sand and repaint, using a non lead-based paint meeting the requirements of Title 16 CRF Part 1303.
5. Inspect wood parts monthly. The grain of the wood sometimes will lift in the dry season causing splinters to appear. Light sanding may be necessary to maintain a safe environment. Treating your Product with protection (sealant) after sanding will help prevent severe checking/splitting and other weather damage.
6. We have applied a waterborne translucent stain to your unit. This is done for color only. Once or twice a year, depending on your climate conditions, you must apply some type of protection (sealant) to the wood of your unit. Prior to the application of sealant, lightly sand any "rough" spots on your set. Please note this is a requirement of your warranty.

## Outdoor Product Assembly Manual FAQs:

1. Is the wood treated with chemicals? Backyard Discovery uses 100% Chinese Cedar wood which is naturally bug resistant, decay and rot resistant. To help ensure your families safety, our wood is completely chemical free and we do not use pressure-treated wood. The stain we use is a top coat using a water-based product that is for appearance only.
2. How often should the product be stained? Backyard Discovery recommends the product be stained once each year. A water or oil based stain can be used at the customer's discretion.
3. Why does it seem that my product is developing cracks? Wood is a natural material; no two pieces are exactly alike. Each piece has its own characteristics and personality and reacts differently to climate changes. When any wood product is exposed to the elements, it develops "wood checks". A check is the radial separation of the wood fibers running with the grain of the wood. These are caused by the varying temperature and moisture conditions. A check is not a crack – it does not affect the strength or durability of the wood or structural integrity of the product.
4. Do Backyard Discovery products come with a warranty? Yes. All Backyard Discovery products carry a 1-year replacement warranty on all parts for manufacturer's defect. Our wood carries a 5 year warranty on rot and decay as well. Please see warranty details for more information.
5. What is the best way to get started assembling the product? Backyard Discovery recommends taking all the parts out of the boxes and arranging them by part number before you begin any assembly. This will not only allow faster assembly, but will also identify any parts that may be missing or damaged so they can be replaced before assembly. If parts are missing or need replacement, go to [www.swingsetonline.com/support.aspx](http://www.swingsetonline.com/support.aspx) and follow the prompts to order them. Next, read the assembly manual and get the tools ready for the job as recommended in the manual. If the assembly manual is lost or misplaced a new one can be printed from Backyard Discovery's website: [www.swingsetonline.com](http://www.swingsetonline.com) .
6. The 2"x4" boards do not measure 2"x 4". Why not? In the U.S. it's common practice to describe lumber dimensions using the rough cut sizes from the sawmill and not the finished dimensions. Retailers, home stores, etc. all use this accepted practice for describing lumber dimensions. However, Backyard Discovery products are designed and constructed using the actual dimensions so everything fits properly and remains so during the life of the product.

For more information and frequently asked questions, please refer to our website at [www.swingsetonline.com](http://www.swingsetonline.com) .

# Basic Setup Dimensions

Place the set on level ground, not less than 6 ft [2 m] from any structure or obstruction such as a fence, garage, house, overhanging branches, laundry lines, or electrical wires.

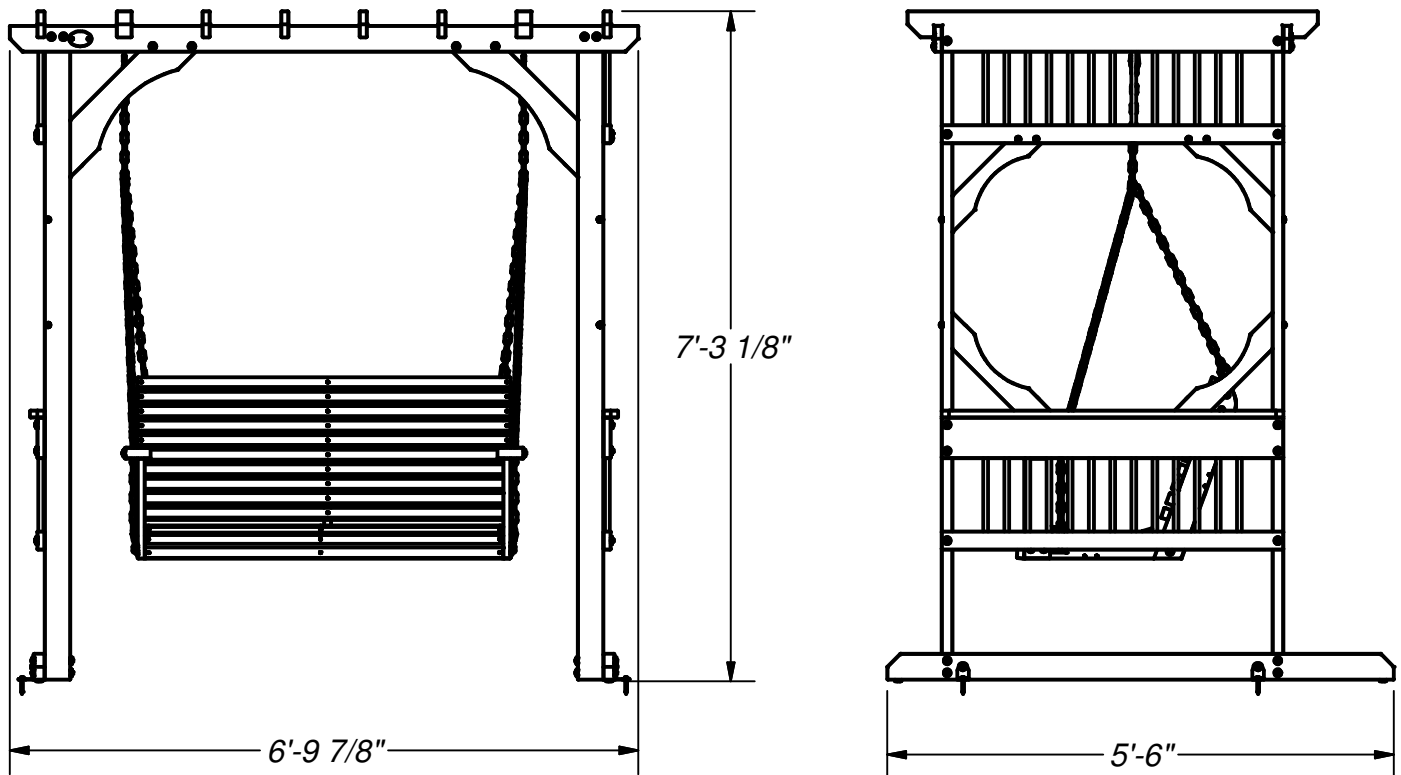

## GENERAL INFORMATION:

Your pergola swing has been designed and engineered for residential use only. A maximum weight of 600 lbs. is recommended for the swing seat.

## Important Assembly Notes

- 1) While assembling unit, take time before and after each phase to make sure unit is level. If unit is not level, assembly will be difficult and improper assembly may result. Extra care must be taken to ensure the unit is square.
- 2) Pay close attention to the *ITEMS NEEDED FOR EACH PHASE*. They can be a valuable aid when sorting your wood and hardware. Assembly will be made easier if items are sorted by phase.
- 3) Pay close attention to make sure you are using the correct hardware in the correct phases. Using incorrect hardware may result in improper assembly.
- 4) Whenever a T-nut is used, follow these directions. Place T-nut in pre-drilled hole. Tap in with hammer. Place bolt with washers in the opposite side. Hand tighten to make sure the bolt is in the T-nut. **DO NOT** over tighten.
- 5) Read the steps of each phase thoroughly. The written steps may include important information not shown in the illustrations.

# Parts Identification

## Wood Components

(NOT TO SCALE)



- (1) **E1 - LEFT ARM REST - W4L05540**  
1 3/8"x3 3/8"x26 5/8" (36x86x677)



- (1) **E2 - RIGHT ARM REST - W4L05541**  
1 3/8"x3 3/8"x26 5/8" (36x86x677)



- (4) **E3 - POST - W4L06374**  
1 3/8"x3 3/8"x85" (36x86x2160)



- (2) **E4 - GROUND BOARD - W4L05460**  
1 3/8"x3 3/8"x66" (36x86x1676)



- (2) **G1 - SHELF - W4L05459**  
1"x5 1/4"x44 1/2" (24x134x1130)

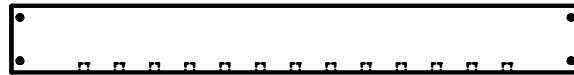

- (2) **G2 - MIDDLE RAIL - W4L06376**  
1"x5 1/4"x44 1/2" (24x134x1130)

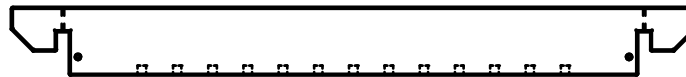

- (2) **G3 - END RAFTER - W4L06378**  
1"x5 1/4"x53 1/2" (24x134x1358)



- (4) **G4 - SUPPORT BRACE - W4L05470**  
1"x5 1/4"x25" (24x134x634)



- (2) **H1 - BEAM - W4L05462**  
1"x3 3/8"x81 7/8" (24x86x2080)

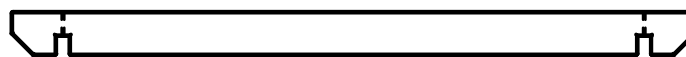

- (4) **H2 - CENTER RAFTER - W4L05465**  
1"x3 3/8"x53 1/2" (24x86x1358)



- (4) **H3 - LOWER BRACE - W4L05467**  
1"x3 3/8"x18" (24x86x458)



- (4) **H4 - UPPER BRACE - W4L05468**  
1"x3 3/8"x18" (24x86x458)

# Parts Identification

## Wood Components

(NOT TO SCALE)



- (2) **H5 - SIDE BACK RAIL - W4L05546**  
1"x3 3/8"x24 3/4" (24x86x630)



- (1) **H8 - CENTER SEAT SUPPORT - W4L05549**  
1"x3 3/8"x21 3/4" (24x86x551)



- (2) **H9 - SIDE SEAT SUPPORT - W4L05550**  
1"x3 3/8"x21 3/4" (24x86x551)



- (2) **H10 - SWING RAIL SUPPORT - W4L05544**  
1"x3 3/8"x13" (24x86x330)



- (1) **H11 - CENTER BACK RAIL - W4L05547**  
1"x3 3/8"x24 3/4" (24x86x630)



- (2) **J1 - LOWER RAIL - W4L06375**  
1"x2 3/8"x44 1/2" (24x60x1130)



- (2) **J2 - UPPER RAIL - W4L06377**  
1"x2 3/8"x44 1/2" (24x60x1130)



- (1) **M1 - SWING SEAT SUPPORT - W4L05545**  
5/8"x3 3/8"x44 3/4" (16x86x1138)



- (1) **M2 - SWING BACK SUPPORT - W4L05548**  
5/8"x3 3/8"x46 3/4" (16x86x1186)



- (10) **T2 - SWING BACK BOARD - W4L05542**  
1"x1 3/8"x48 5/8" (24x36x1234)



- (12) **T3 - SWING SEAT BOARD - W4L05543**  
1"x1 3/8"x46 3/4" (24x36x1186)



- (2) **W1 - SWING SUPPORT - W4L05466**  
2"x3 3/8"x53 1/2" (50x86x1358)



# Parts Identification

## Hardware



(2) VW - SCREW PFH 8x1/2 BLK - H100203



(9) - SCREW PFH 8x2 BLK - H100391



(70) BP - SCREW PFH 8x1 1/2 - H100086



(13) - SCREW PFH 8x3 BLK - H100362



(13) BS - SCREW PFH 8x1 3/4 - H100089



(2) CY - SCREW PWH 8x5/8 - H100128



(4) BT - SCREW PFH 8x2 1/2 - H100090

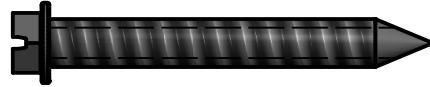

(4) CQ - CONCRETE ANCHOR 1/4" x 2" - H100120



(7) - BOLT HEX 5/16x1-1/2 - BLK - H100498



(4) - NUT BARREL WH 5/16x5/8 BLK - H100469

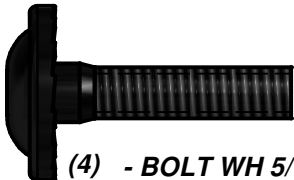

(4) - BOLT WH 5/16x1 1/4 BLK - H100459

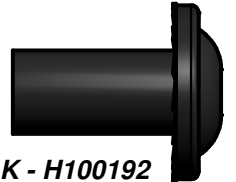

(32) VK - NUT BARREL WH 5/16x7/8 BLK - H100192

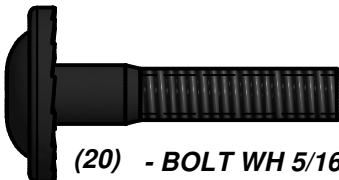

(20) - BOLT WH 5/16x1 1/2 BLK - H100407



(13) VL - NUT BARREL WH 5/16x1-1/2 BLK - H100193



(9) - BOLT WH 5/16x2 BLK - H100457



(4) VY - BOLT WH 5/16x2-1/4 BLK - H100205

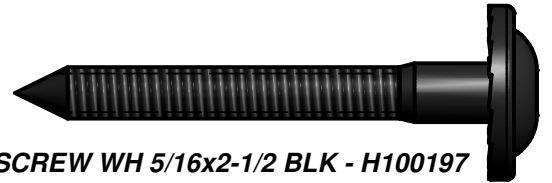

(18) VQ - LAG SCREW WH 5/16x2-1/2 BLK - H100197

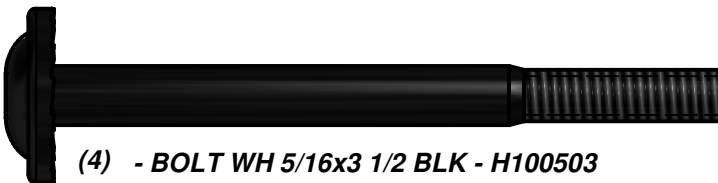

(4) - BOLT WH 5/16x3 1/2 BLK - H100503



(4) VZ - LAG SCREW WH 5/16x3 BLK - H100206

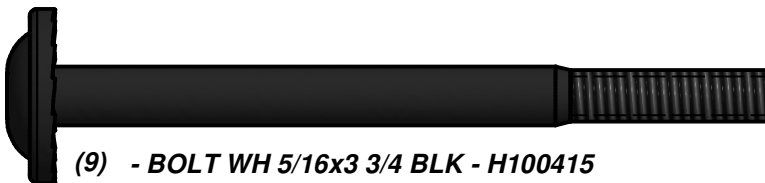

(9) - BOLT WH 5/16x3 3/4 BLK - H100415

# Parts Identification

## Hardware

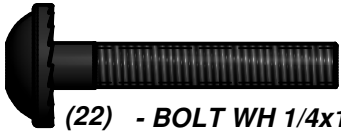

(22) - BOLT WH 1/4x1 1/2 BLK - H100406



(4) - NUT BARREL WH 1/4x5/8 BLK - H100404



(4) - LAG SCREW WH 1/4x2 BLK - H100487



(18) - NUT BARREL WH 1/4x7/8 BLK - H100399



(66) VR - WASHER LOCK EXT 8x19 BLK - H100198

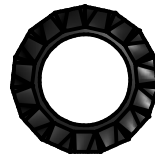

(48) VS - WASHER LOCK EXT 12x19 BLK - H100199

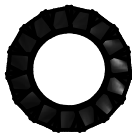

(22) - WASHER LOCK EXT 8x15 BLK - H100400



(26) - WASHER LOCK EXT 6x15 BLK - H100405



(17) - WASHER FLAT 9x18 BLK - H100474

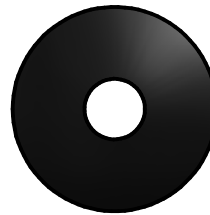

(2) - WASHER FLAT 8x27 BLK - H100478

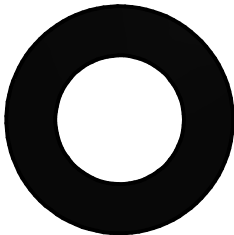

(2) - WASHER SAFETY 17x30 - BLK - H100497



(9) - NUT LOCK 5/16 BLK - H100479



(2) - SWING HANGER QUICK LINK 86 BOARD - BLK - H100496

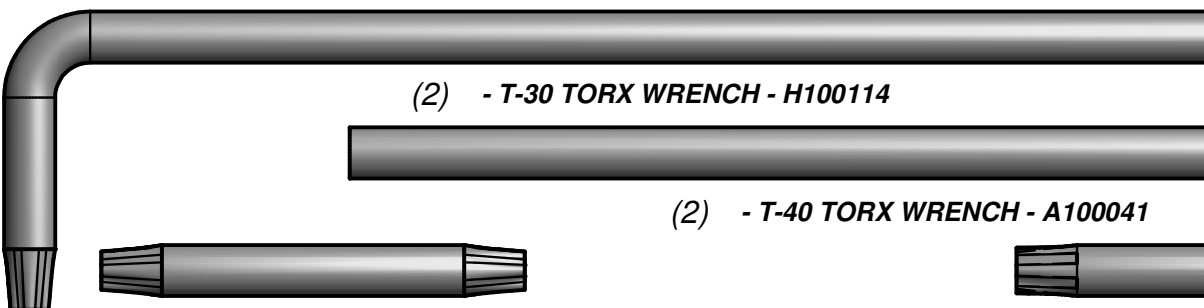

(2) - T-30 TORX WRENCH - H100114



(2) - T-40 TORX WRENCH - A100041



(2) - T-30 TORX BIT - H100147



(2) - T-40 TORX BIT - A100042

# Parts Identification

Accessories  
(NOT TO SCALE)



(2) - TIE STRAP PLATE - A4M00631



(4) - QUICK LINK - A4M00633

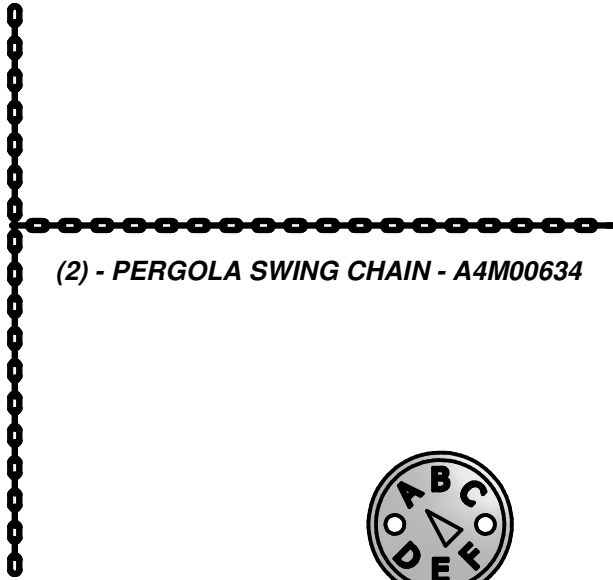

(2) - PERGOLA SWING CHAIN - A4M00634

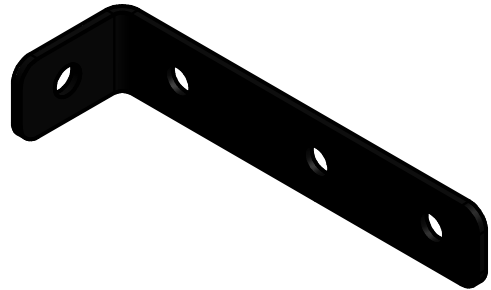

(2) - CHAIN SUPPORT BRACKET - A4M00632



(1) SQ - "A" REVISION TAG - A100314



(1) XR - BYD ID TAG (SMALL) WITHOUT AGES - A100241

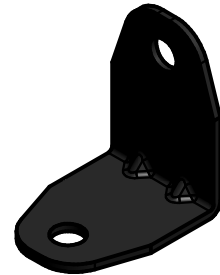

(4) - L BRACKET 2.5x38x50x55 - A4M00615



(4) - GROUND STAKE REBAR - A4M00527



(4) - PERGOLA SWING FOOT - A6P00081

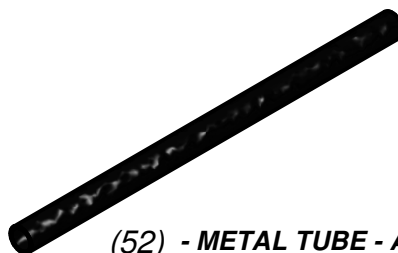

(52) - METAL TUBE - A4M00608

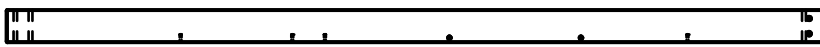

(2) **E3 - POST - W4L06374**  
1 3/8"x3 3/8"x85" (36x86x2160)



(1) **J2 - UPPER RAIL - W4L06377**  
1"x2 3/8"x44 1/2" (24x60x1130)

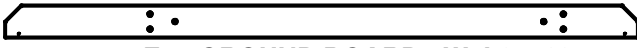

(1) **E4 - GROUND BOARD - W4L05460**  
1 3/8"x3 3/8"x66" (36x86x1676)



(1) **J1 - LOWER RAIL - W4L06375**  
1"x2 3/8"x44 1/2" (24x60x1130)

(2) **- PERGOLA SWING FOOT - A6P00081**

### STEP 1

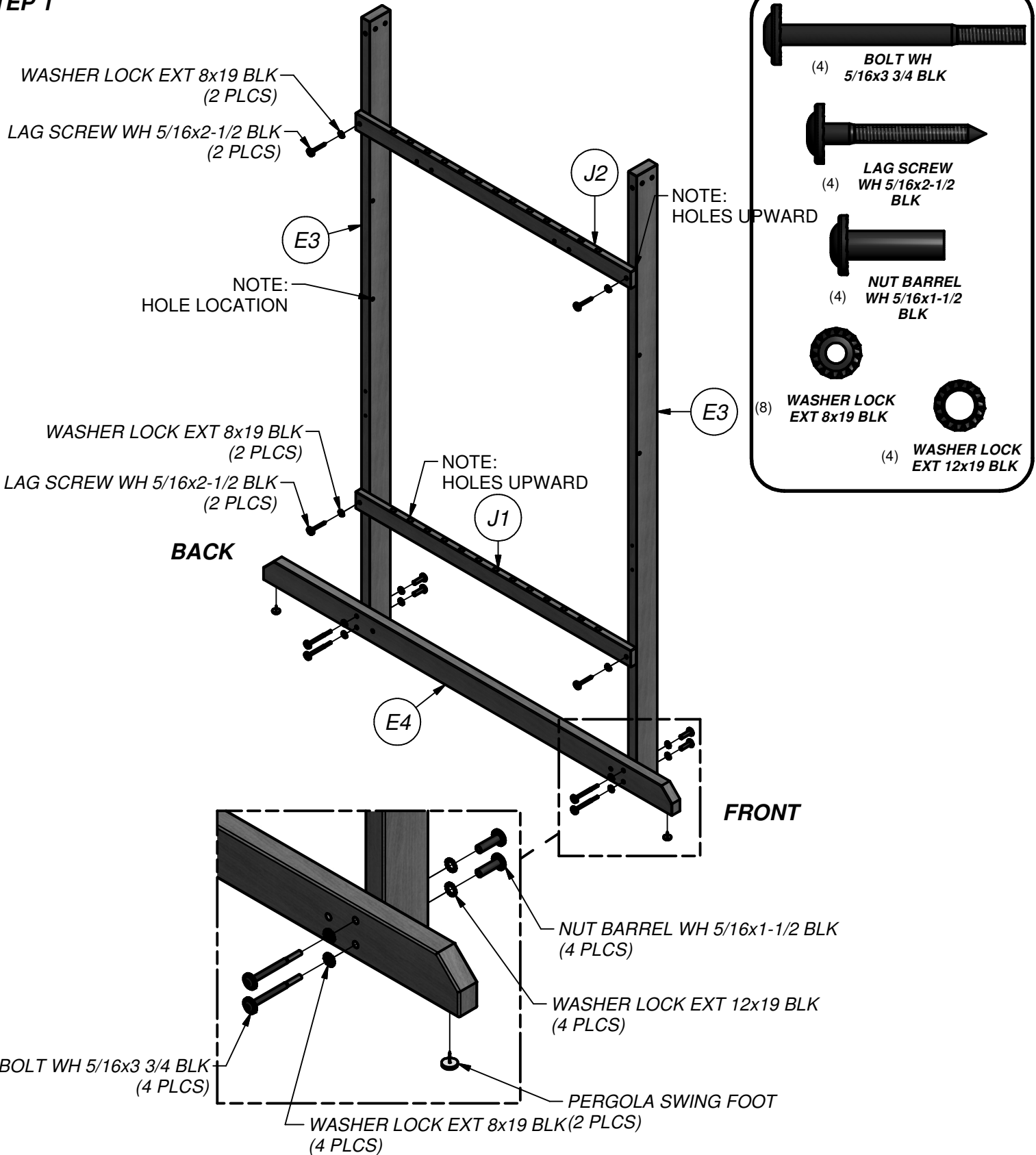



(1) **G2 - MIDDLE RAIL - W4L06376**  
1"x5 1/4"x44 1/2" (24x134x1130)

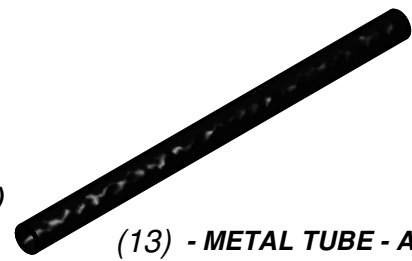

(13) - **METAL TUBE - A4M00608**

**STEP 2**

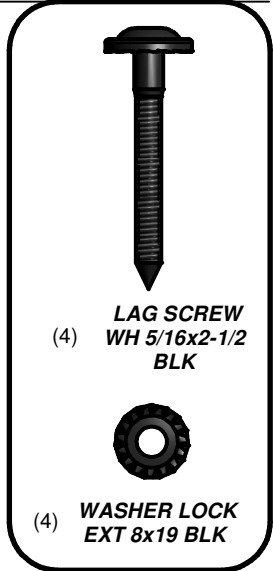
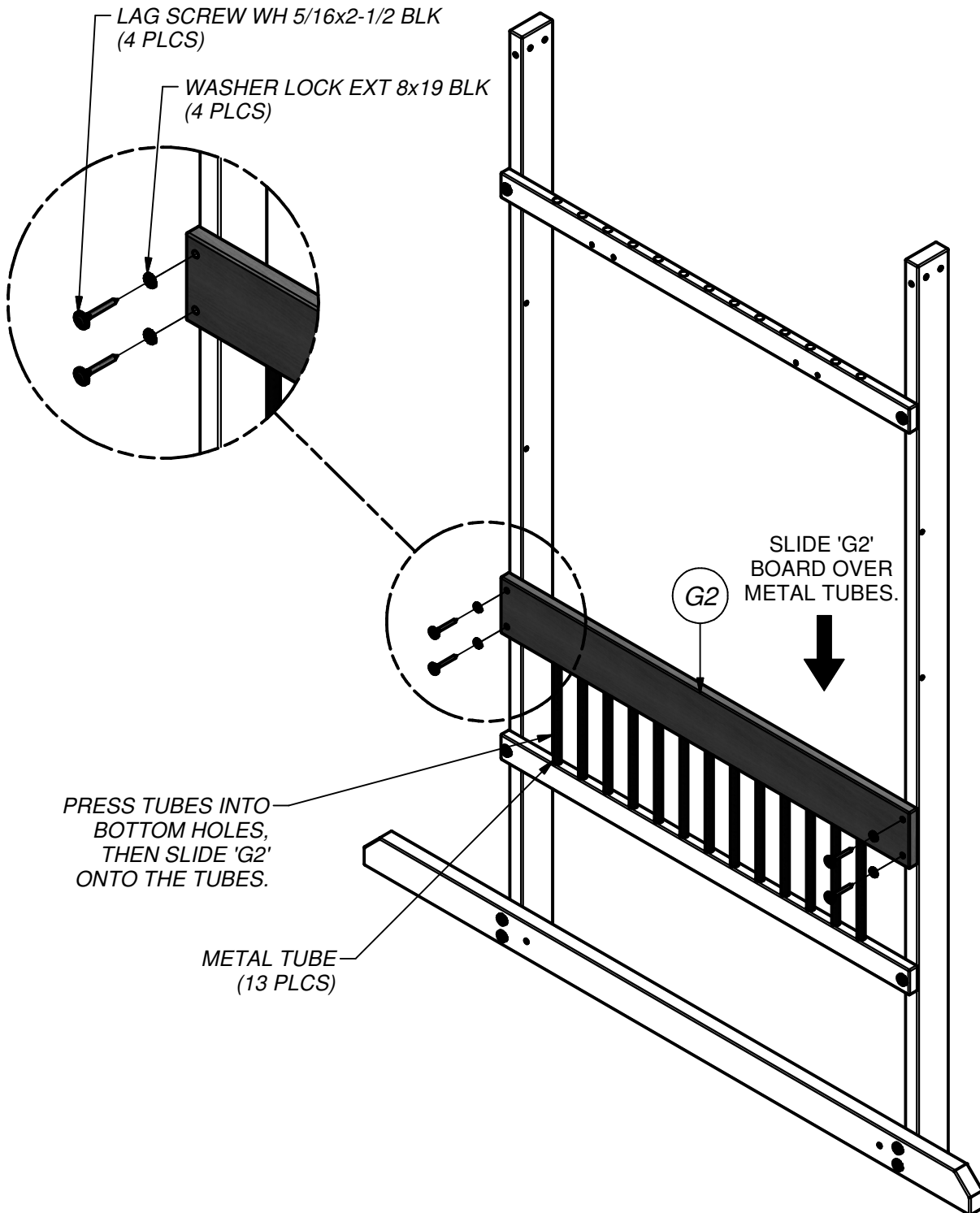



(1) **G3 - END RAFTER - W4L06378**  
1"x5 1/4"x53 1/2" (24x134x1358)

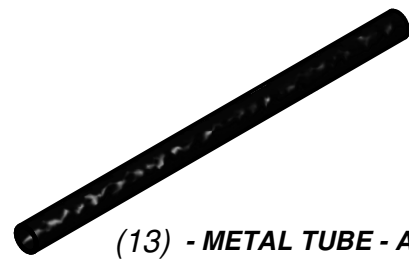

(13) - **METAL TUBE - A4M00608**

**STEP 3**

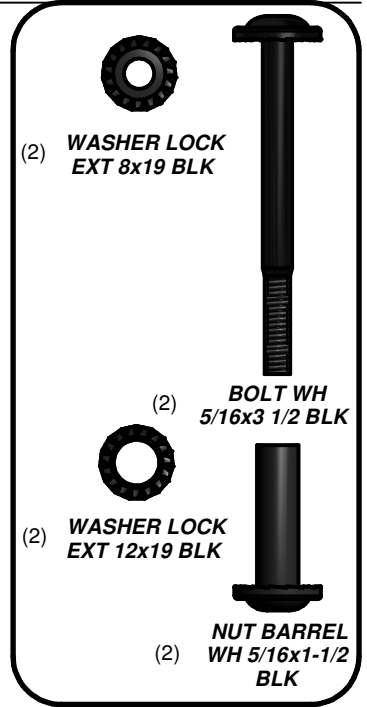
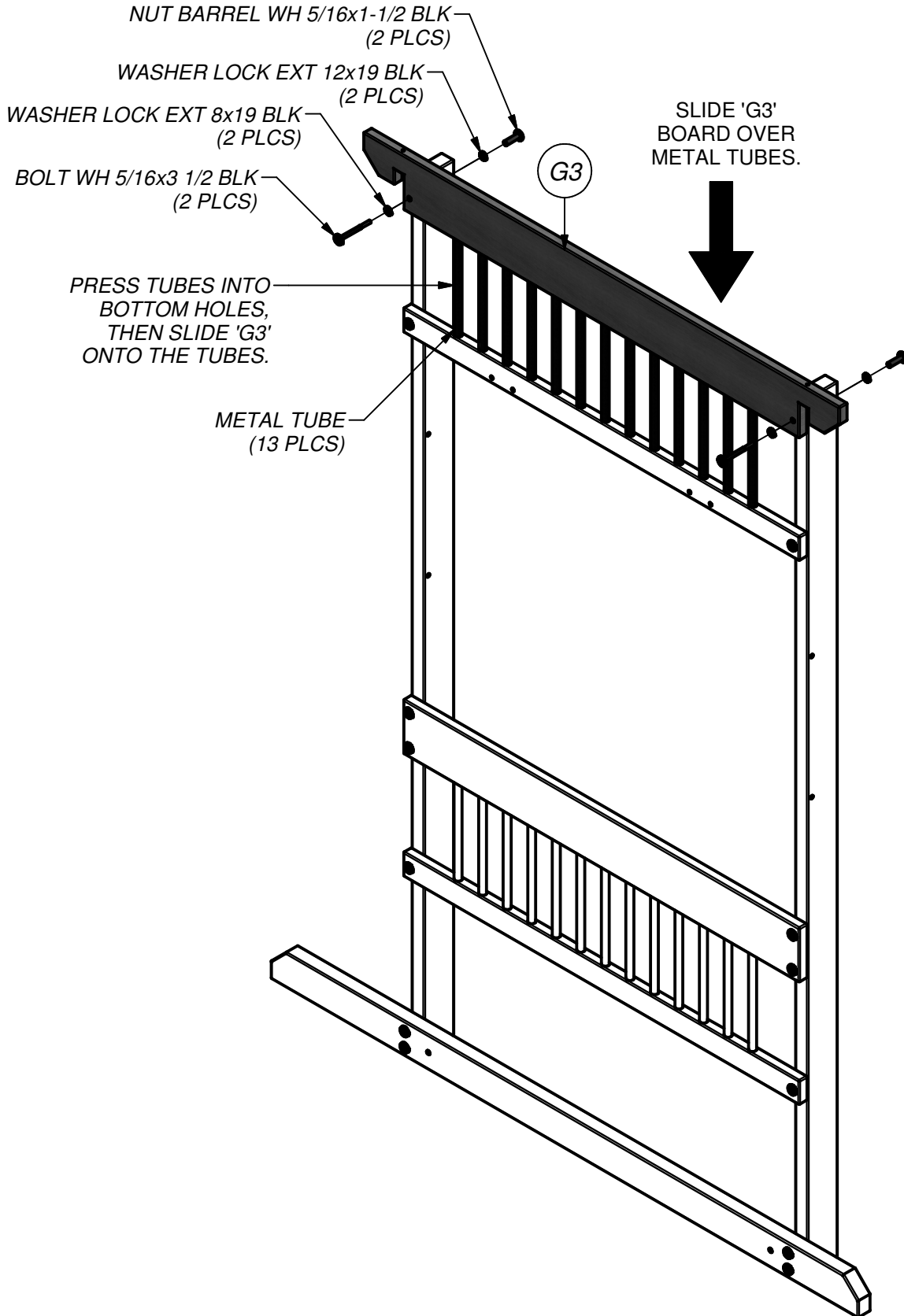

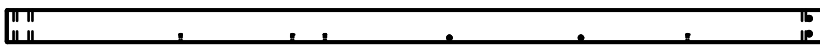

(2) **E3 - POST - W4L06374**  
1 3/8"x3 3/8"x85" (36x86x2160)



(1) **J2 - UPPER RAIL - W4L06377**  
1"x2 3/8"x44 1/2" (24x60x1130)

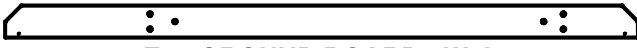

(1) **E4 - GROUND BOARD - W4L05460**  
1 3/8"x3 3/8"x66" (36x86x1676)



(1) **J1 - LOWER RAIL - W4L06375**  
1"x2 3/8"x44 1/2" (24x60x1130)

(2) **- PERGOLA SWING FOOT - A6P00081**

### STEP 4

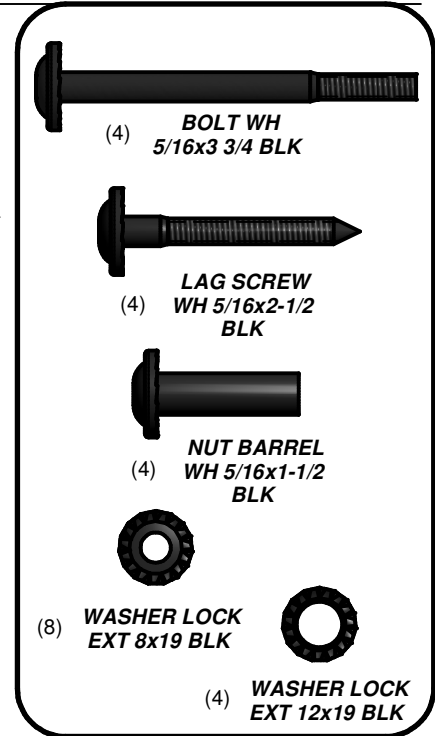
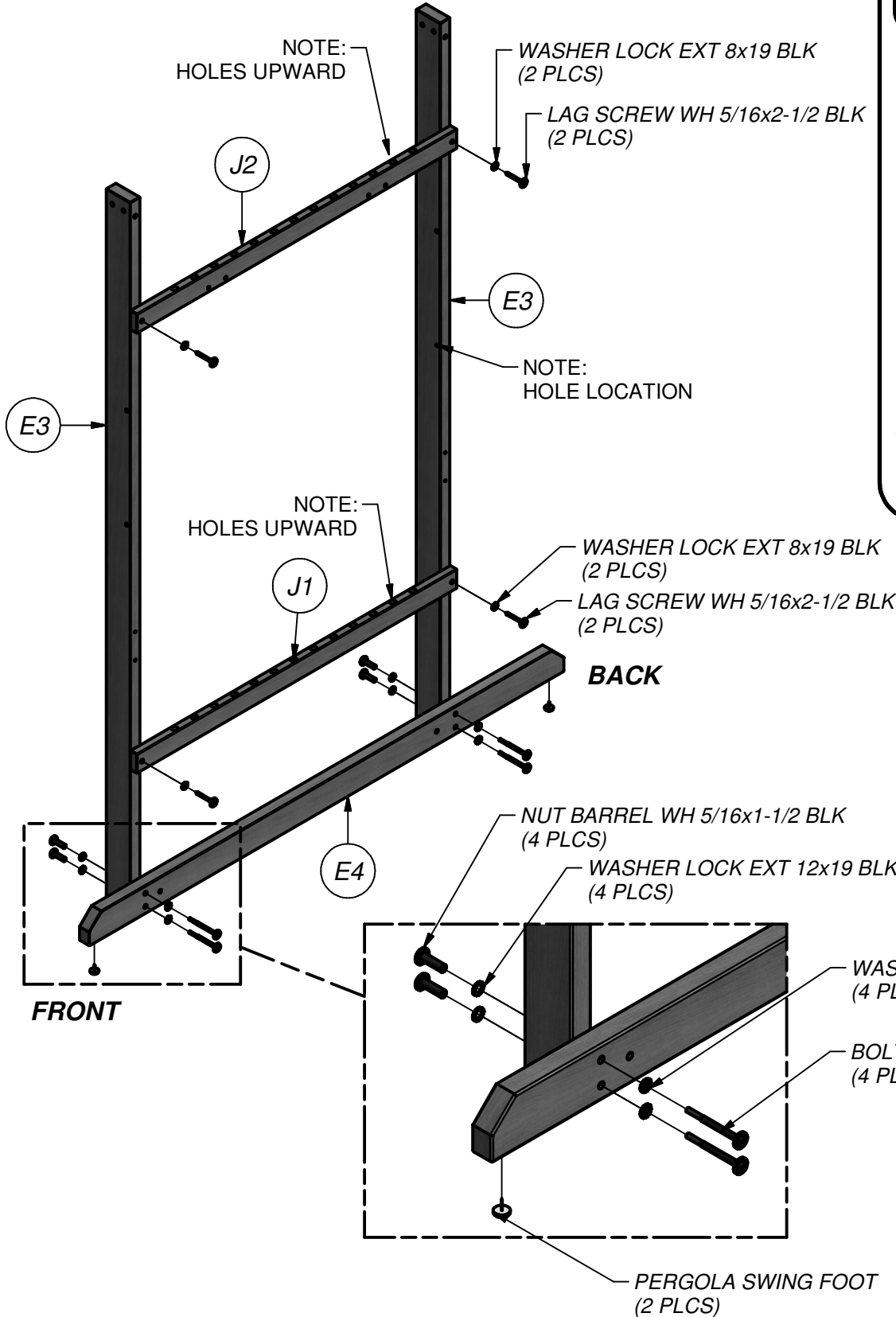



(1) **G2 - MIDDLE RAIL - W4L06376**  
 1"x5 1/4"x44 1/2" (24x134x1130)

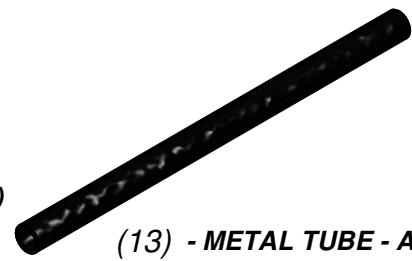

(13) - **METAL TUBE - A4M00608**

**STEP 5**

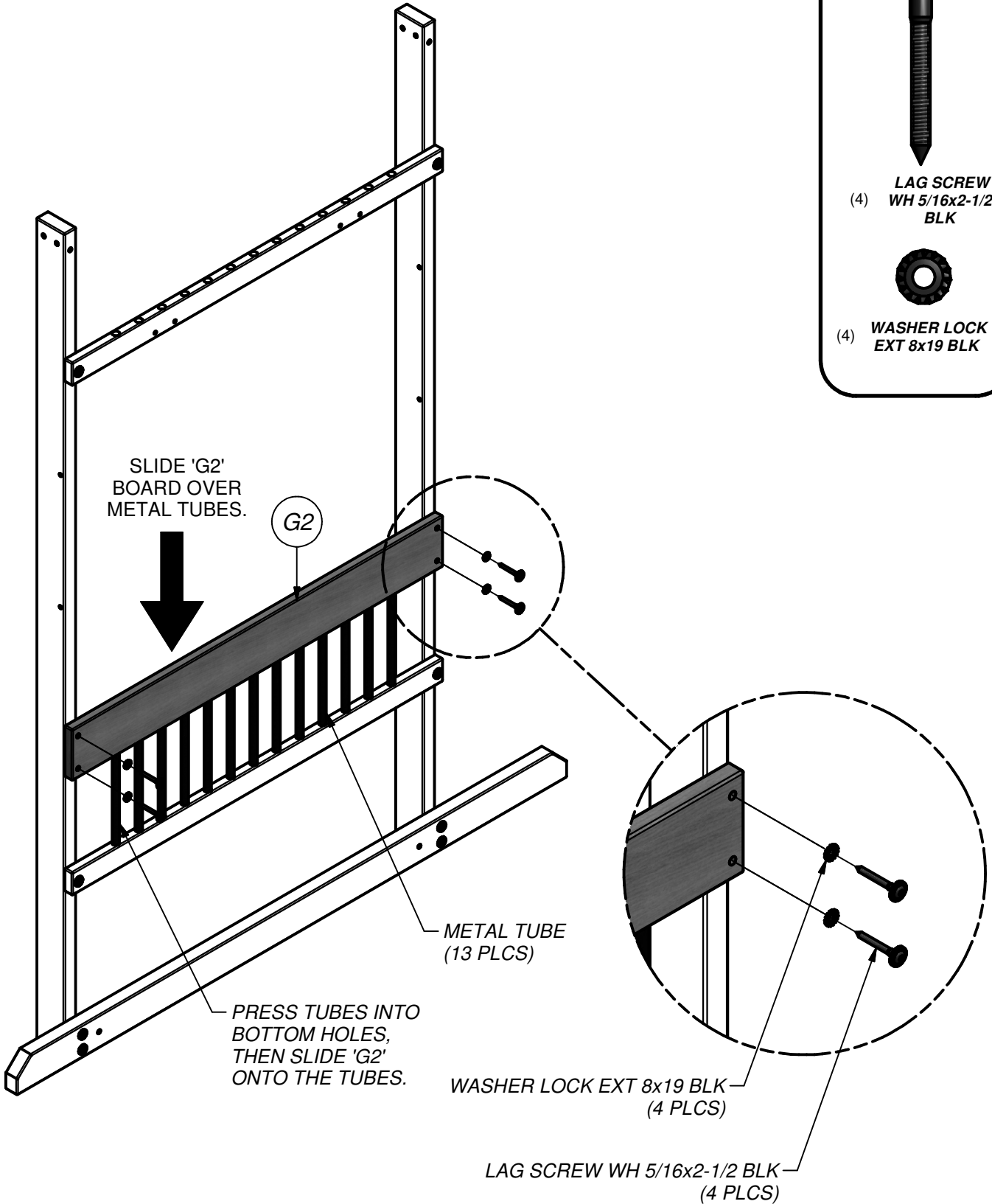

LAG SCREW  
 (4) WH 5/16x2-1/2 BLK

WASHER LOCK  
 (4) EXT 8x19 BLK





(1) **G3 - END RAFTER - W4L06378**  
1"x5 1/4"x53 1/2" (24x134x1358)

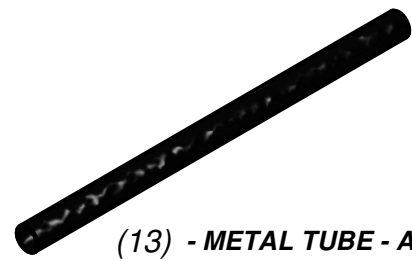

(13) - METAL TUBE - A4M00608

**STEP 6**

SLIDE 'G3'  
BOARD OVER  
METAL TUBES.

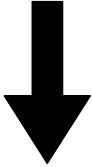

G3

- NUT BARREL WH 5/16x1-1/2 BLK (2 PLCS)
- WASHER LOCK EXT 12x19 BLK (2 PLCS)
- WASHER LOCK EXT 8x19 BLK (2 PLCS)
- BOLT WH 5/16x3 1/2 BLK (2 PLCS)

PRESS TUBES INTO  
BOTTOM HOLES,  
THEN SLIDE 'G3'  
ONTO THE TUBES.

METAL TUBE  
(13 PLCS)

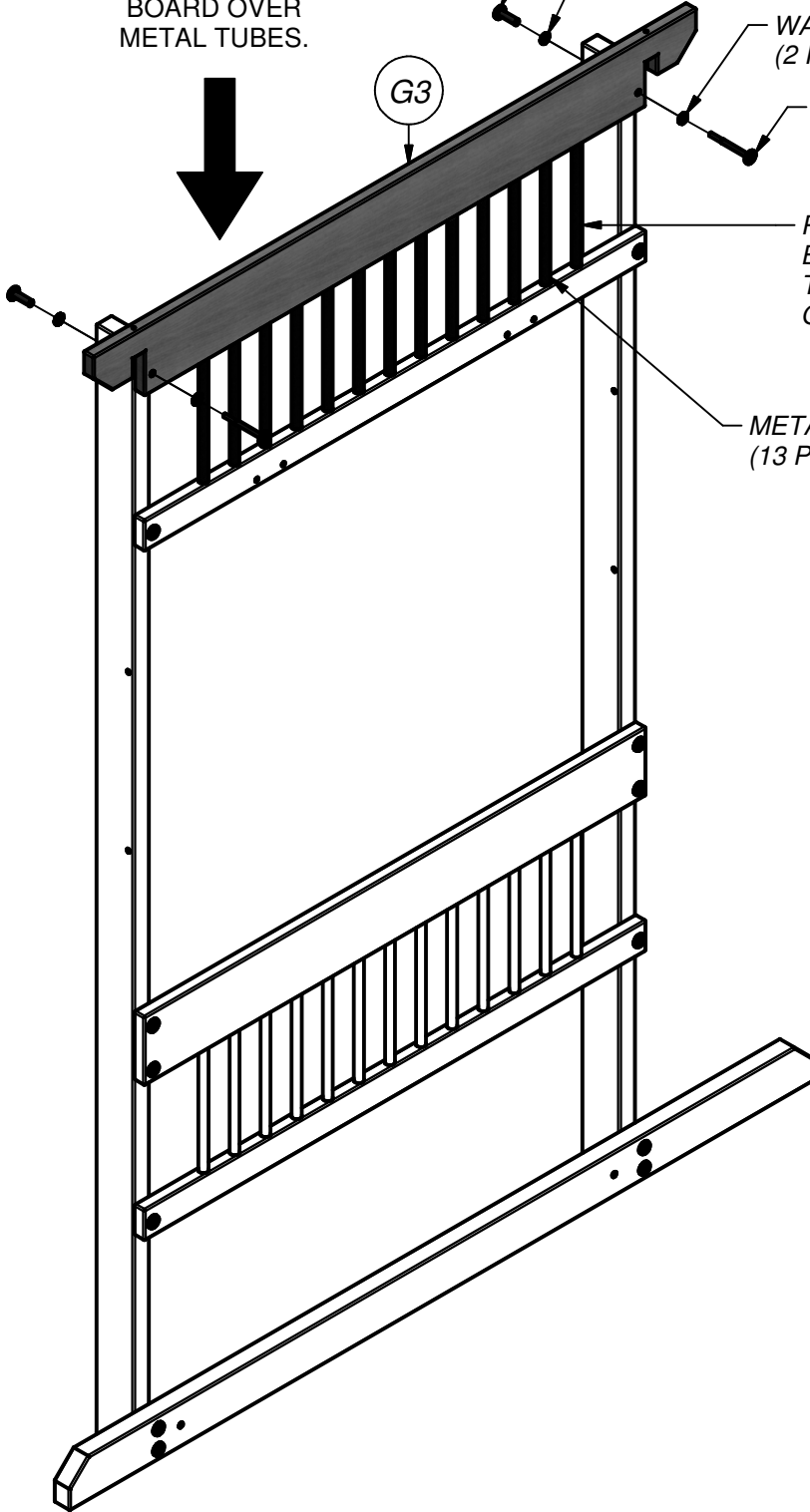
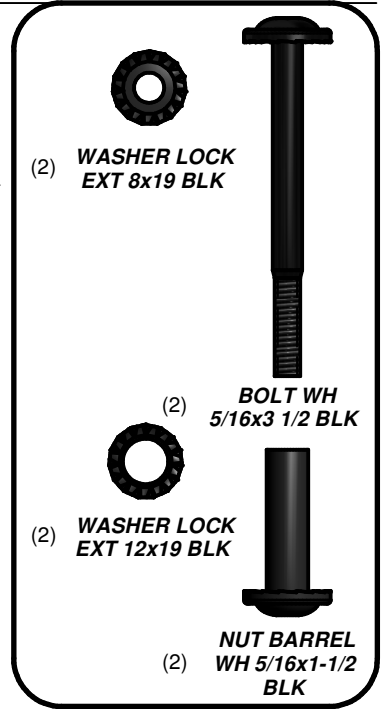



(2) **H1 - BEAM - W4L05462**  
1"x3 3/8"x81 7/8" (24x86x2080)

**STEP 7**

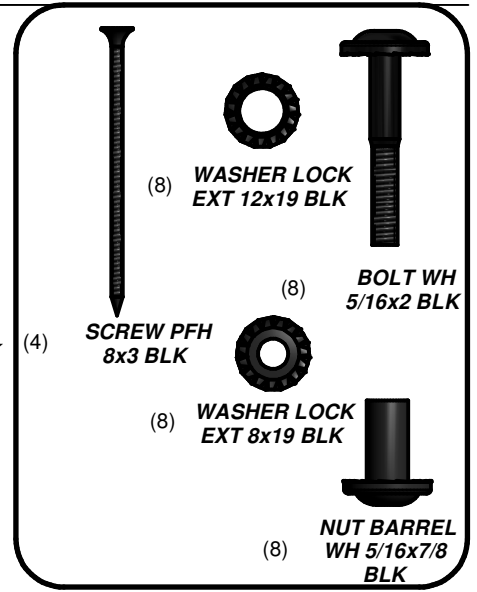
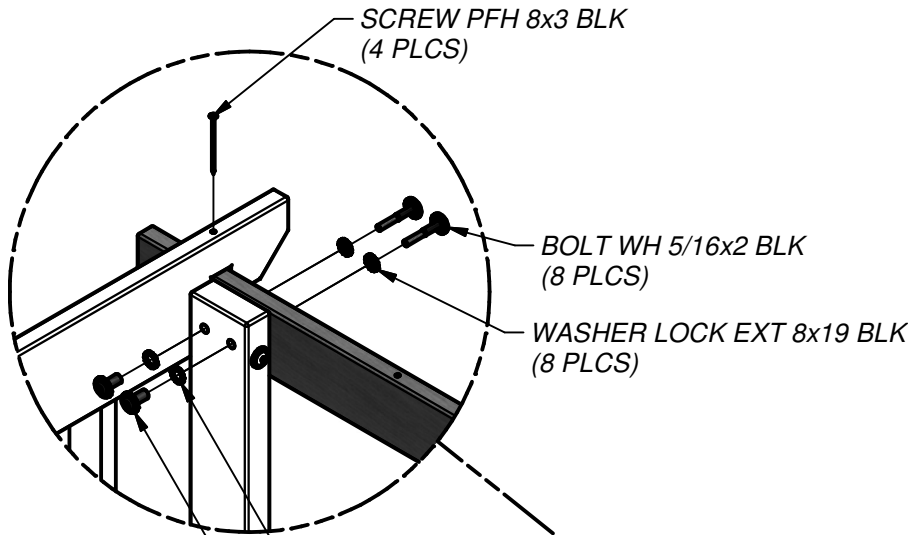

NUT BARREL WH 5/16x7/8 BLK  
(8 PLCS)

WASHER LOCK EXT 12x19 BLK  
(8 PLCS)

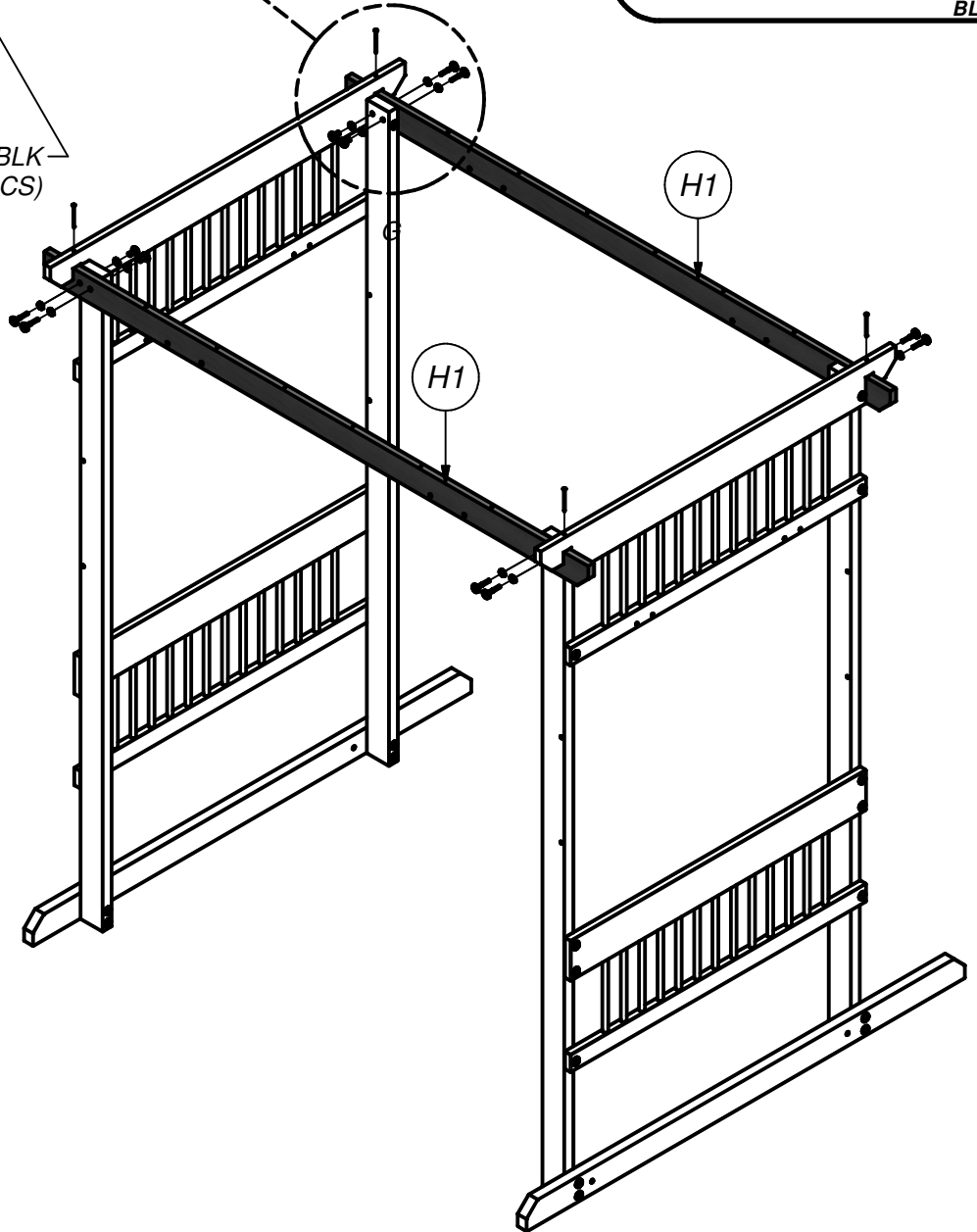



(4) **G4 - SUPPORT BRACE - W4L05470**  
 1"x5 1/4"x25" (24x134x634)

**STEP 8**

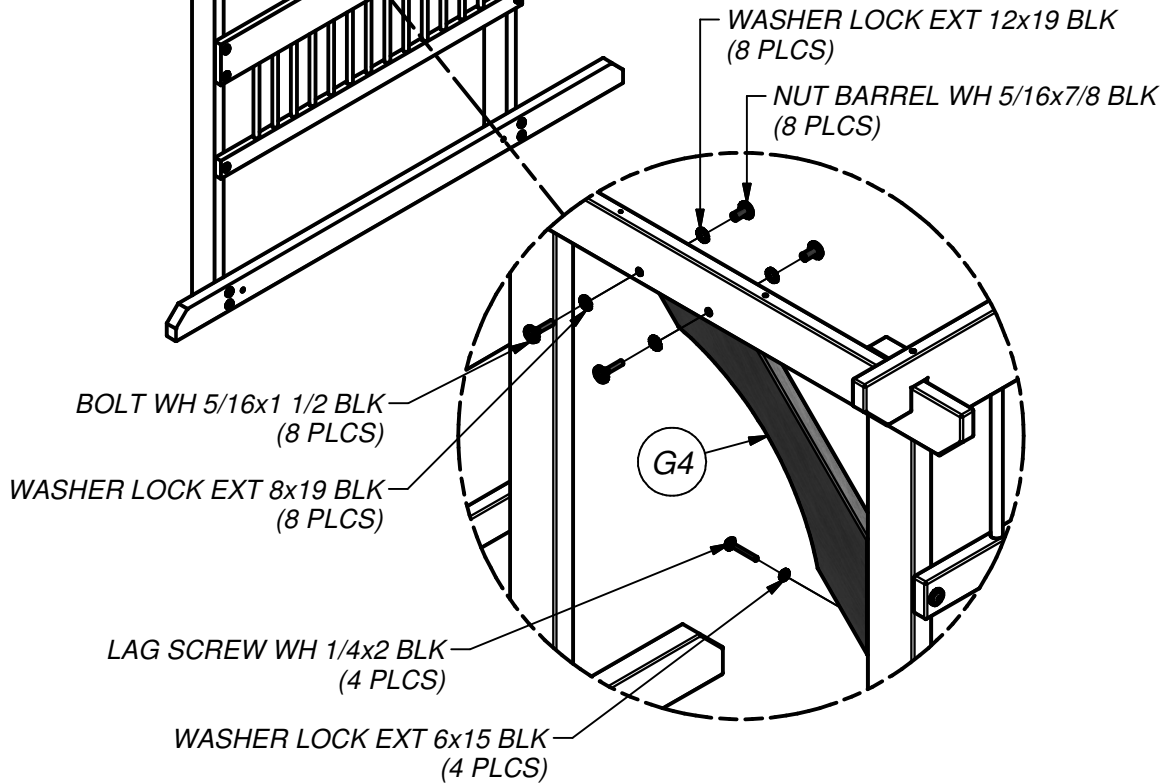
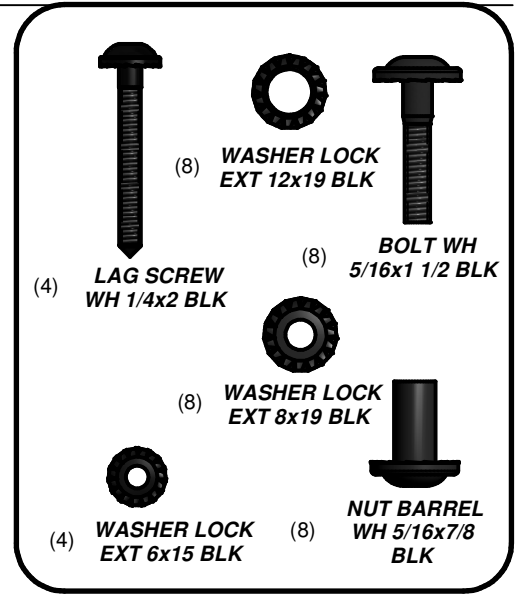
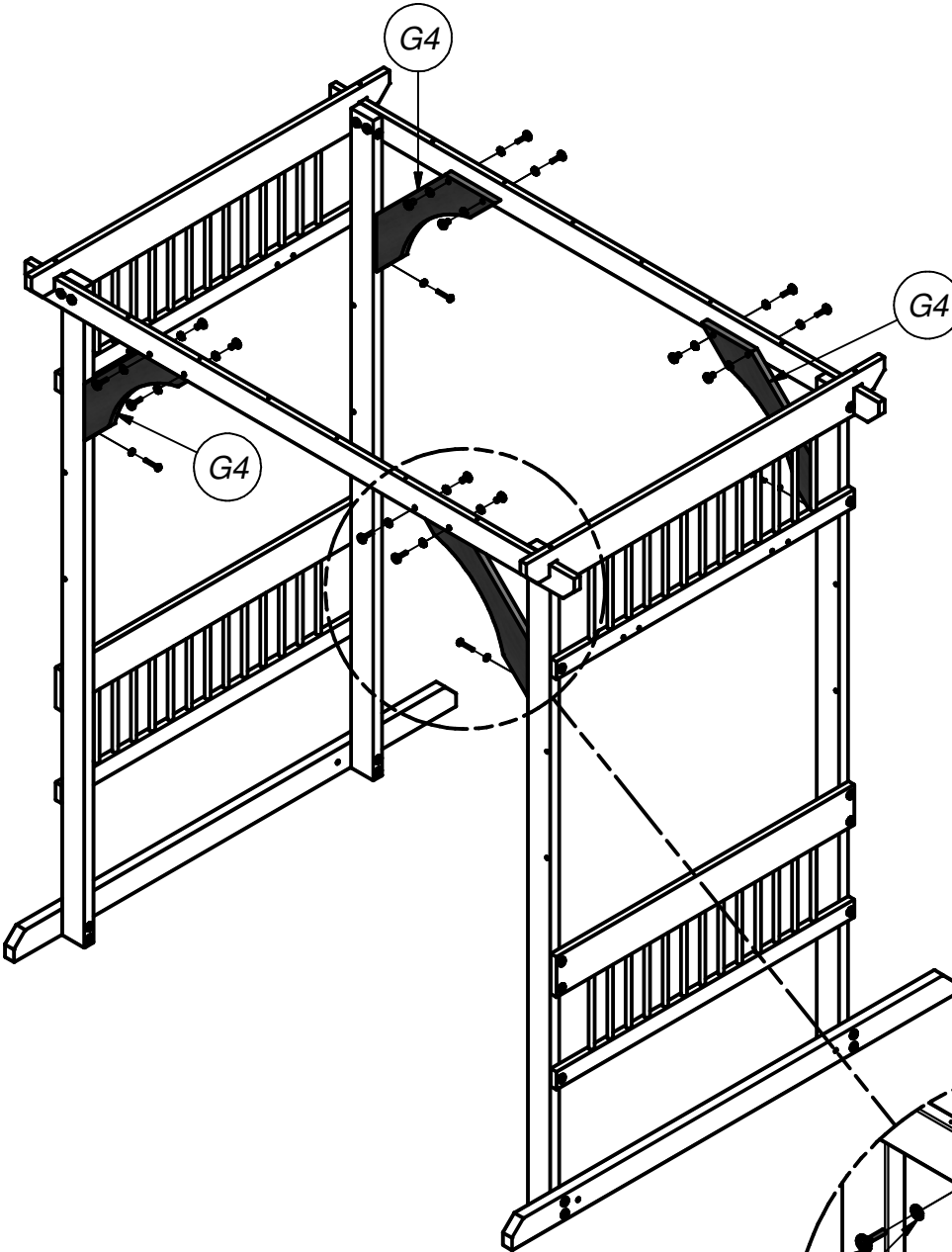



(2) **G1 - SHELF - W4L05459**  
1"x5 1/4"x44 1/2" (24x134x1130)

**STEP 9**

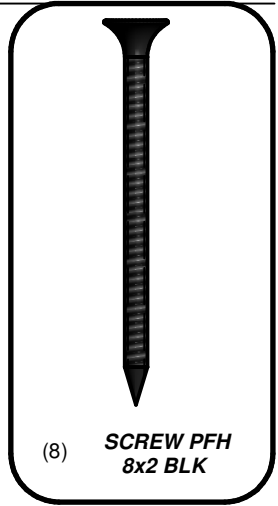
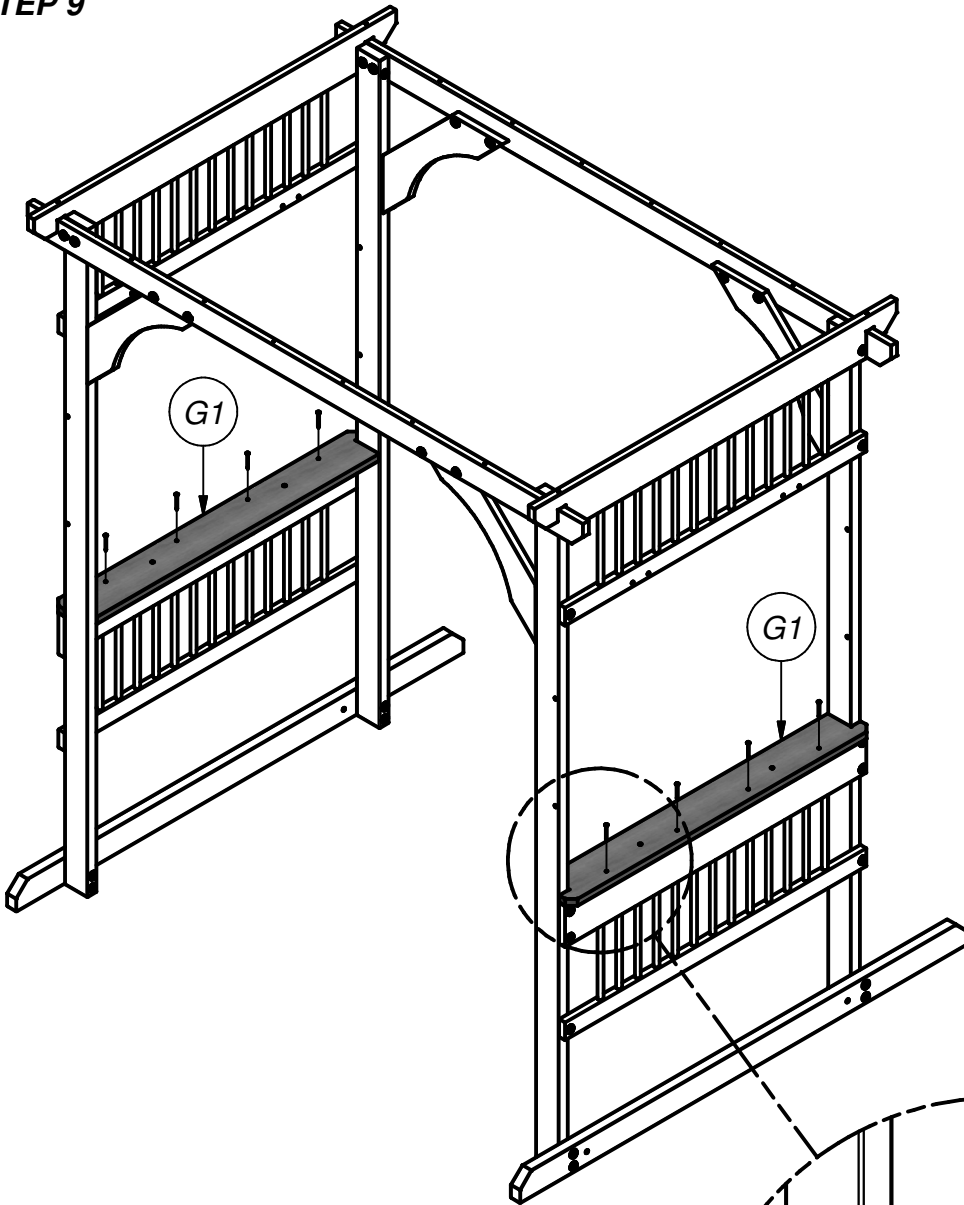

(8) **SCREW PFH**  
8x2 BLK

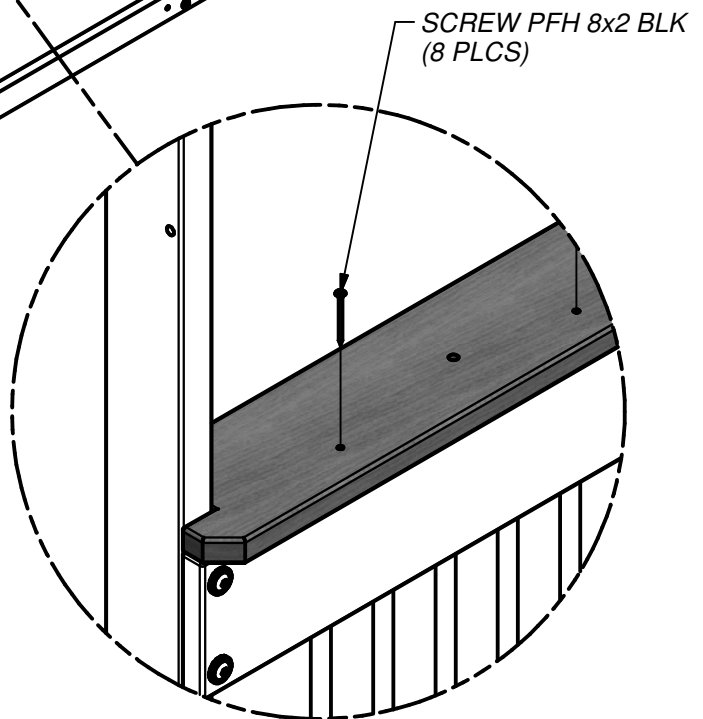

**SCREW PFH 8x2 BLK**  
(8 PLCS)



(4) **H4 - UPPER BRACE - W4L05468**  
 1"x3 3/8"x18" (24x86x458)

**STEP 10**

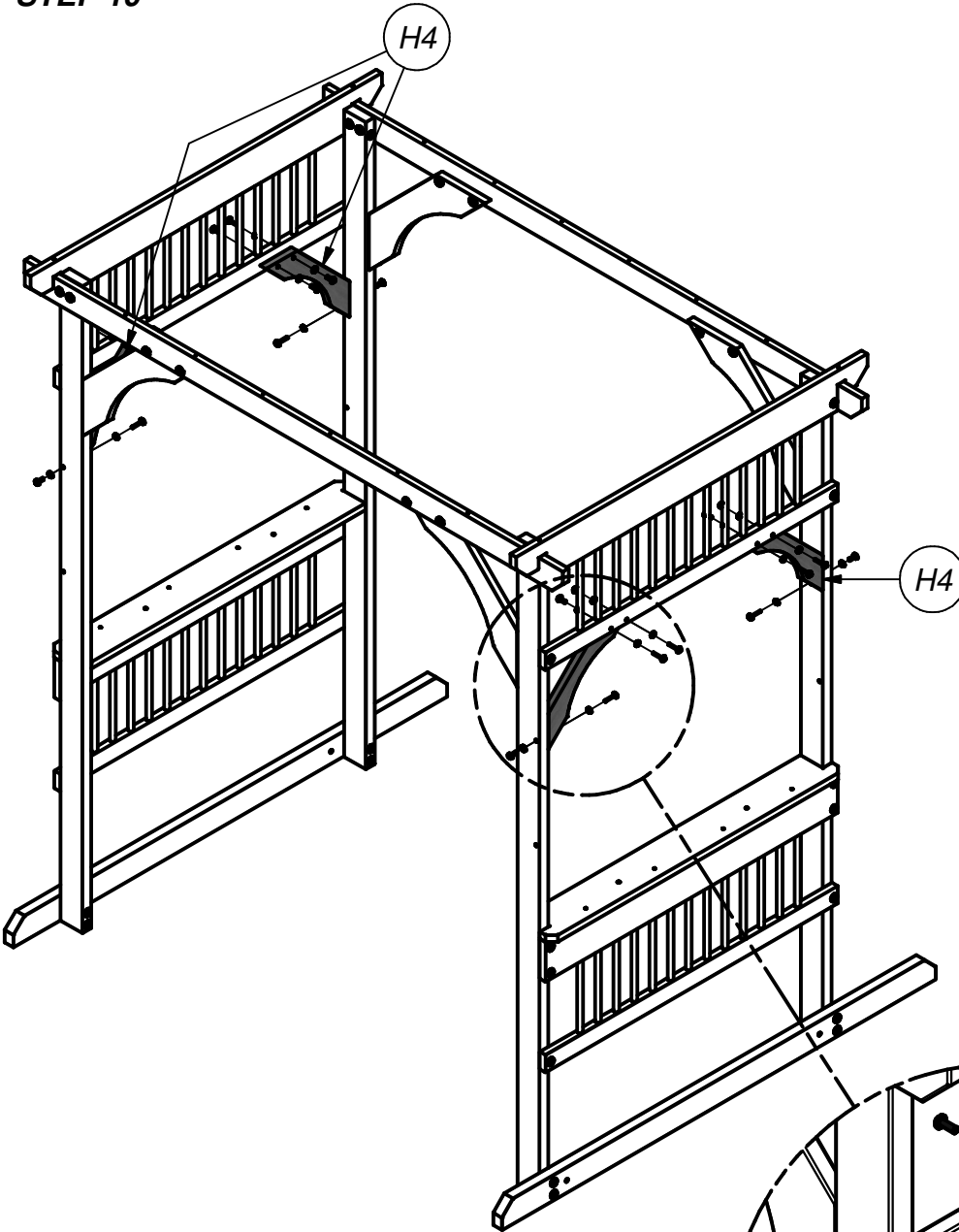

(12) **WASHER LOCK EXT 6x15 BLK**

(12) **BOLT WH 1/4x1 1/2 BLK**

(12) **WASHER LOCK EXT 8x15 BLK**

(12) **NUT BARREL WH 1/4x7/8 BLK**



- NUT BARREL WH 1/4x7/8 BLK (8 PLCS)
- WASHER LOCK EXT 8x15 BLK (8 PLCS)
- WASHER LOCK EXT 6x15 BLK (8 PLCS)
- BOLT WH 1/4x1 1/2 BLK (8 PLCS)
- WASHER LOCK EXT 8x15 BLK (4 PLCS)
- NUT BARREL WH 1/4x7/8 BLK (4 PLCS)
- WASHER LOCK EXT 6x15 BLK (4 PLCS)
- BOLT WH 1/4x1 1/2 BLK (4 PLCS)



(4) **H3 - LOWER BRACE - W4L05467**  
 1"x3 3/8"x18" (24x86x458)

**STEP 11**

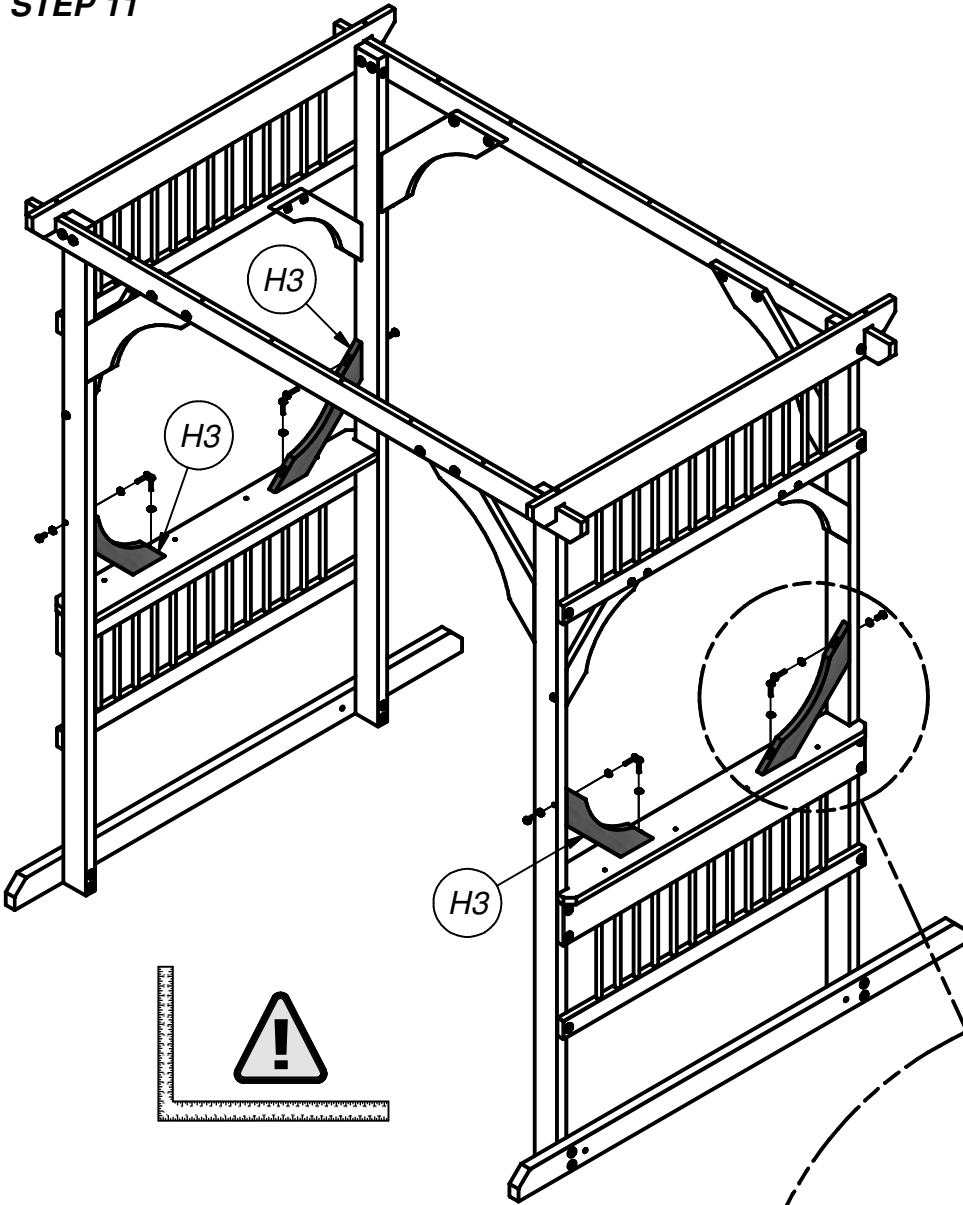

(8) **WASHER LOCK EXT 6x15 BLK**

(8) **BOLT WH 1/4x1 1/2 BLK**

(8) **WASHER LOCK EXT 8x15 BLK**

(4) **NUT BARREL WH 1/4x5/8 BLK**

(4) **NUT BARREL WH 1/4x7/8 BLK**

NUT BARREL WH 1/4x7/8 BLK  
 (4 PLCS)

WASHER LOCK EXT 8x15 BLK  
 (4 PLCS)

WASHER LOCK EXT 6x15 BLK  
 (4 PLCS)

BOLT WH 1/4x1 1/2 BLK  
 (4 PLCS)

BOLT WH 1/4x1 1/2 BLK  
 (4 PLCS)

WASHER LOCK EXT 6x15 BLK  
 (4 PLCS)

WASHER LOCK EXT 8x15 BLK  
 (4 PLCS)

NUT BARREL WH 1/4x5/8 BLK  
 (4 PLCS)

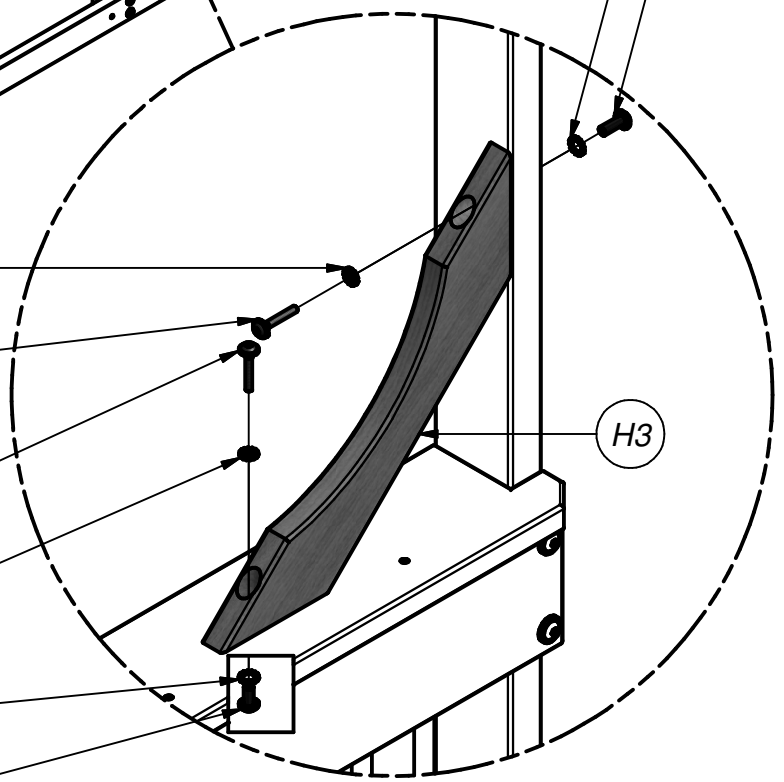

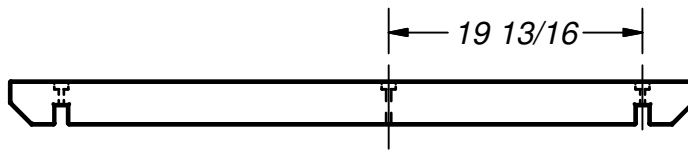

(2) **W1 - SWING SUPPORT - W4L05466**  
 2"x3 3/8"x53 1/2" (50x86x1358)

**STEP 12**

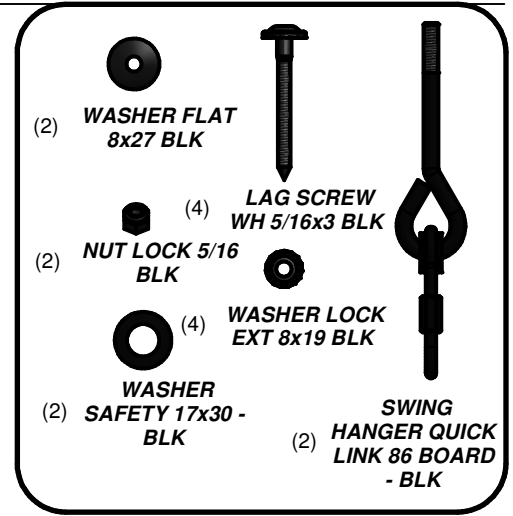
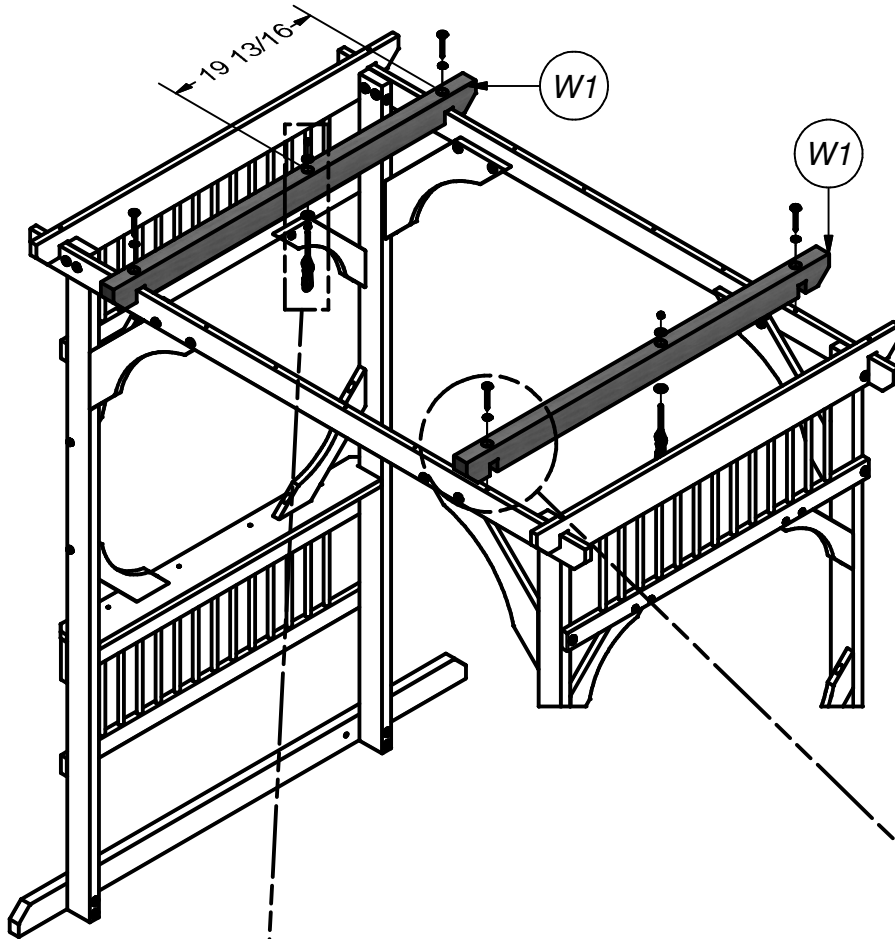

WASHER LOCK EXT 8x19 BLK  
(4 PLCS)

LAG SCREW WH 5/16x3 BLK  
(4 PLCS)

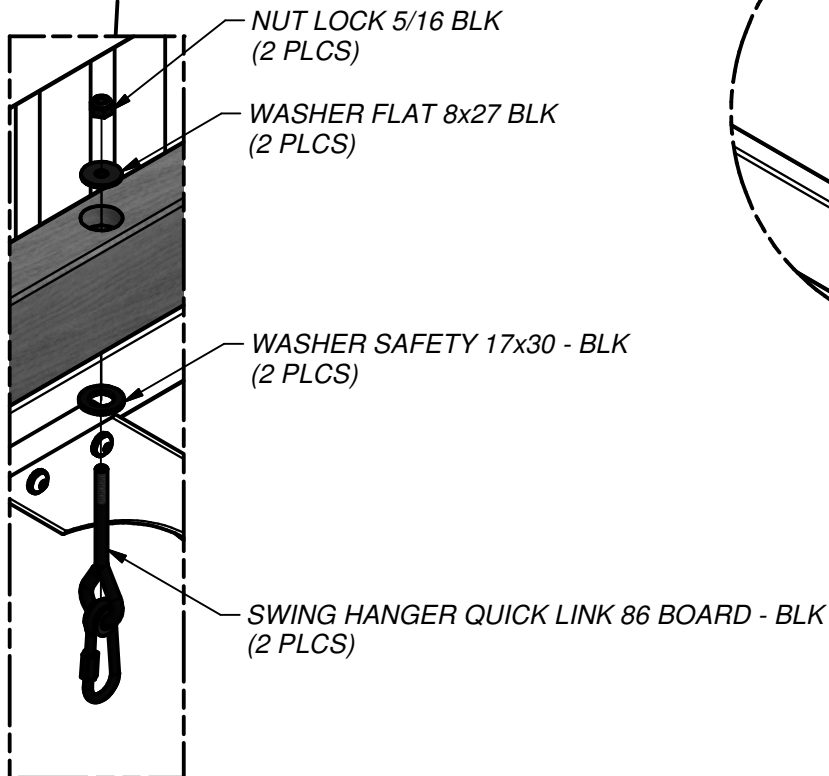
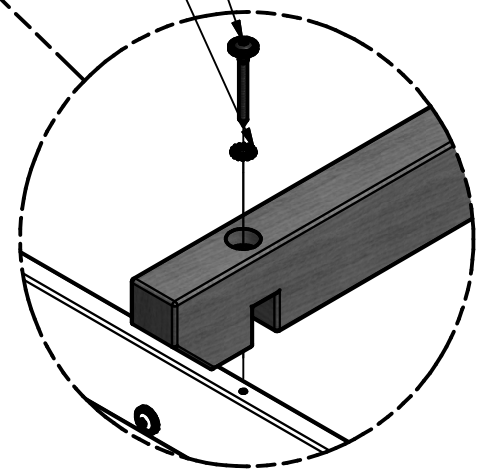



(4) **H2 - CENTER RAFTER - W4L05465**  
**1"x3 3/8"x53 1/2" (24x86x1358)**

**STEP 13**

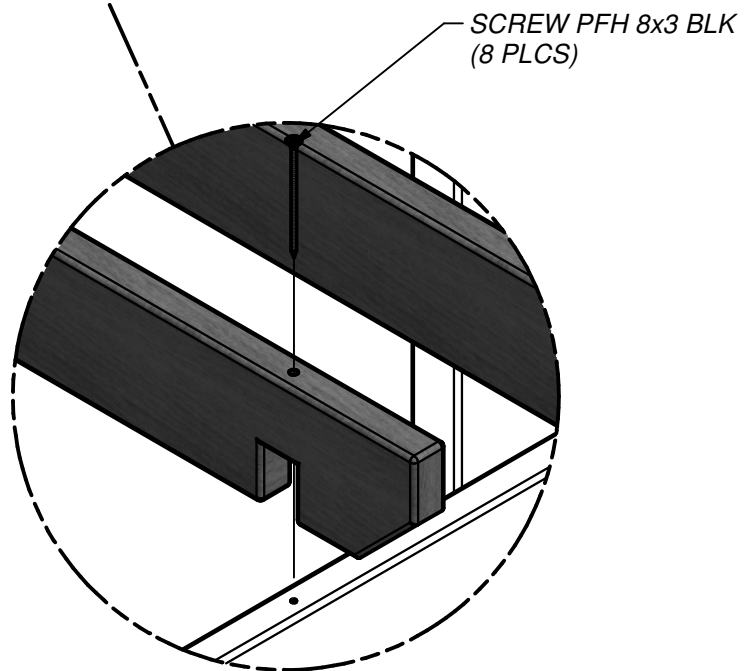
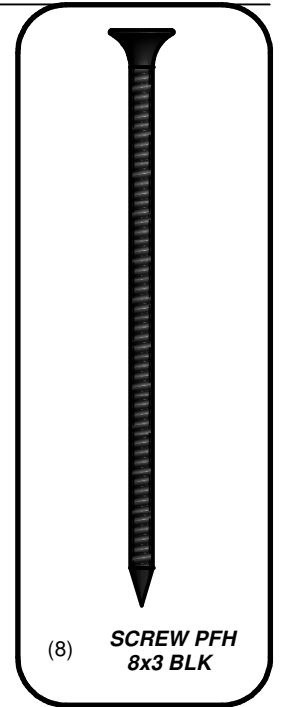
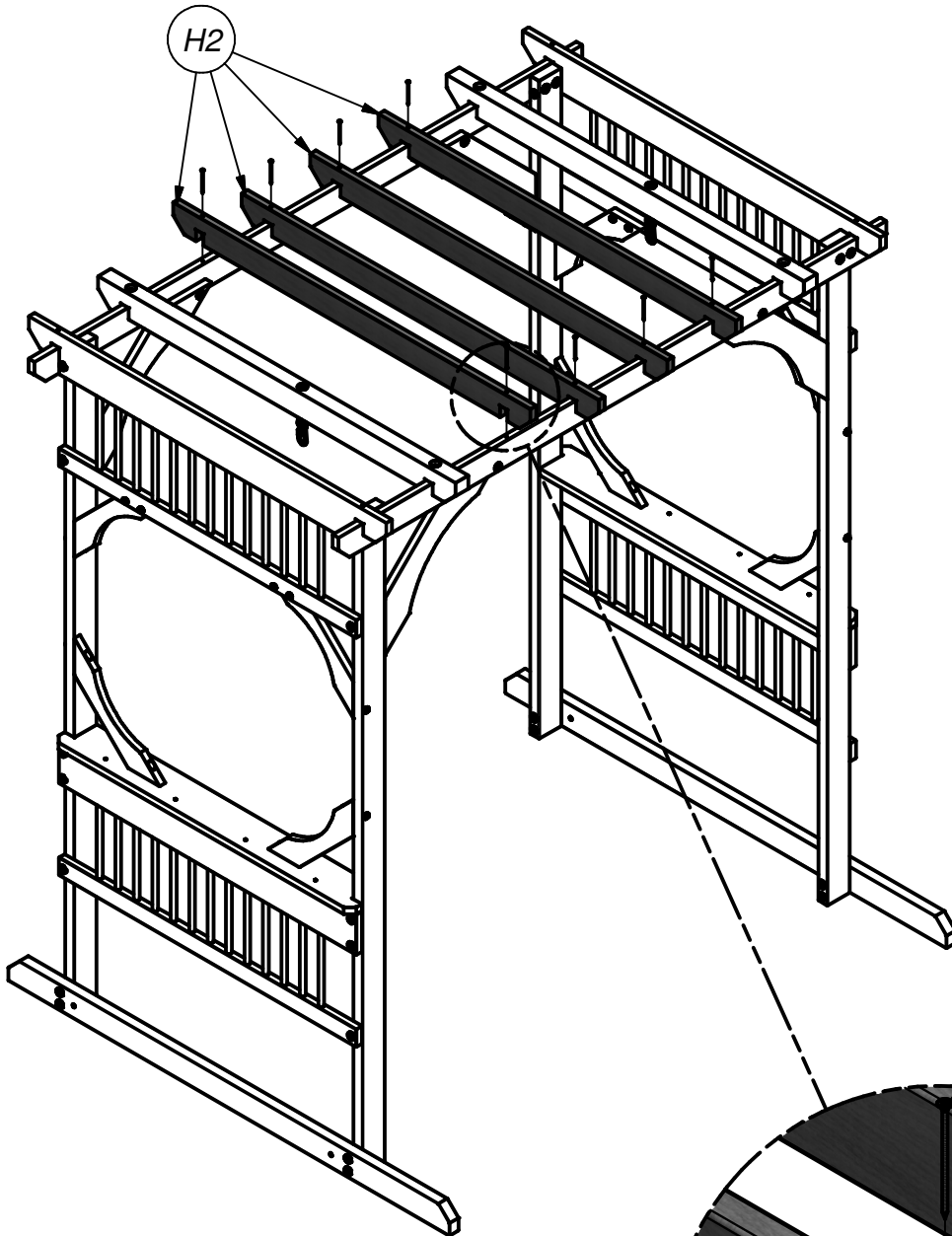



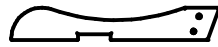

(1) **H8 - CENTER SEAT SUPPORT - W4L05549**  
 1"x3 3/8"x21 3/4" (24x86x551)



(1) **M1 - SWING SEAT SUPPORT - W4L05545**  
 5/8"x3 3/8"x44 3/4" (16x86x1138)



(2) **H9 - SIDE SEAT SUPPORT - W4L05550**  
 1"x3 3/8"x21 3/4" (24x86x551)

**STEP 14**

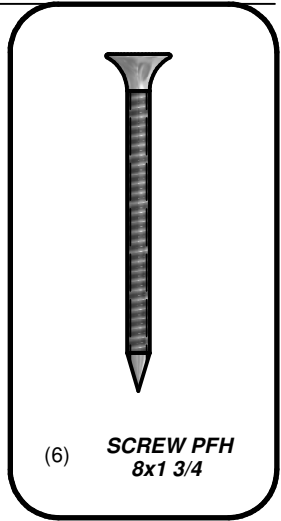
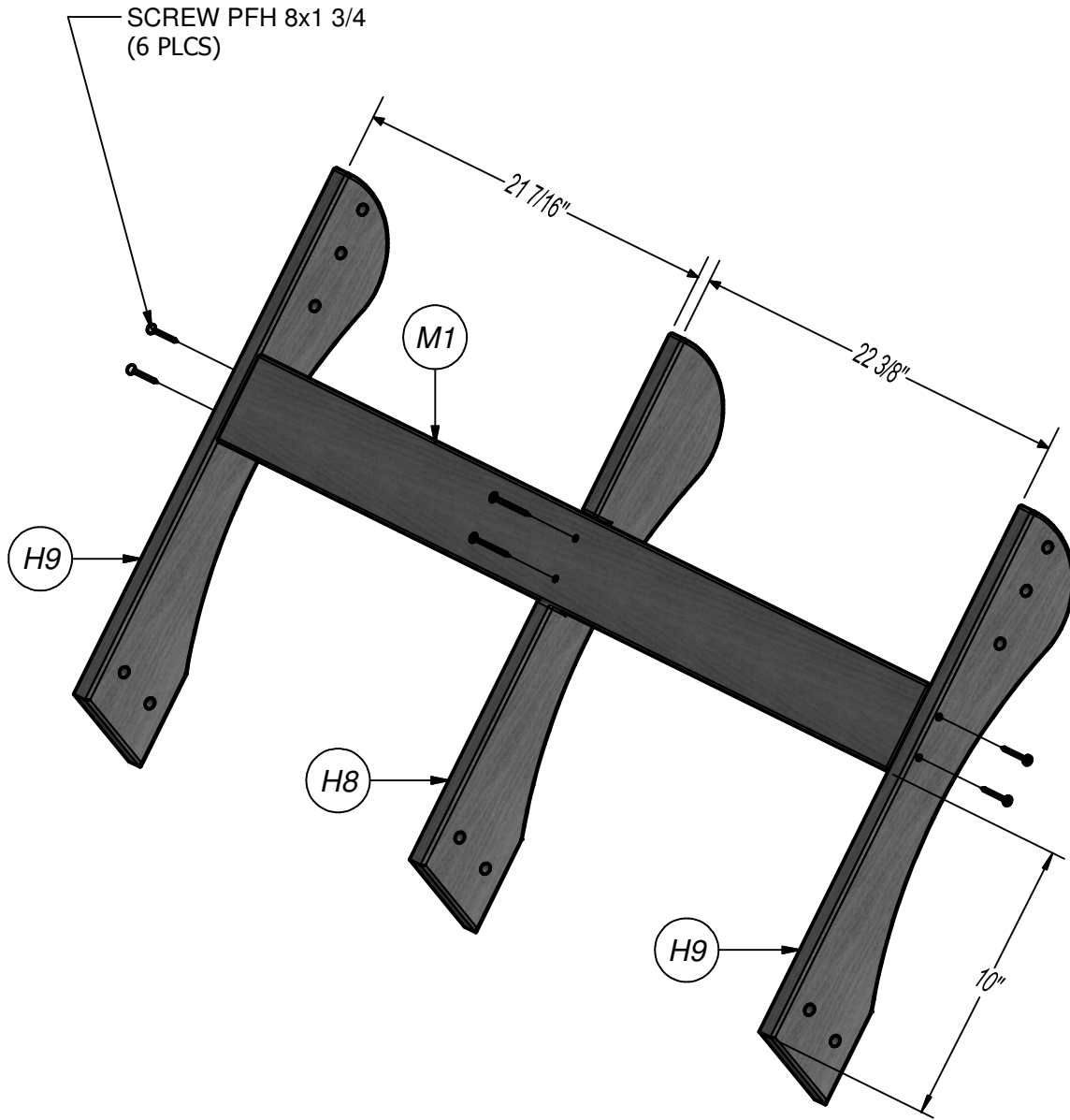

(2) **H5 - SIDE BACK RAIL - W4L05546**  
 1"x3 3/8"x24 3/4" (24x86x630)

(1) **M2 - SWING BACK SUPPORT - W4L05548**  
 5/8"x3 3/8"x46 3/4" (16x86x1186)

(1) **H11 - CENTER BACK RAIL - W4L05547**  
 1"x3 3/8"x24 3/4" (24x86x630)

(2) **- TIE STRAP PLATE - A4M00631**

**STEP 15**

(4) **BOLT HEX**  
 5/16x1-1/2 - BLK

(6) **SCREW PFH**  
 8x1 3/4

(8) **WASHER FLAT**  
 9x18 BLK

(4) **NUT LOCK**  
 5/16 BLK

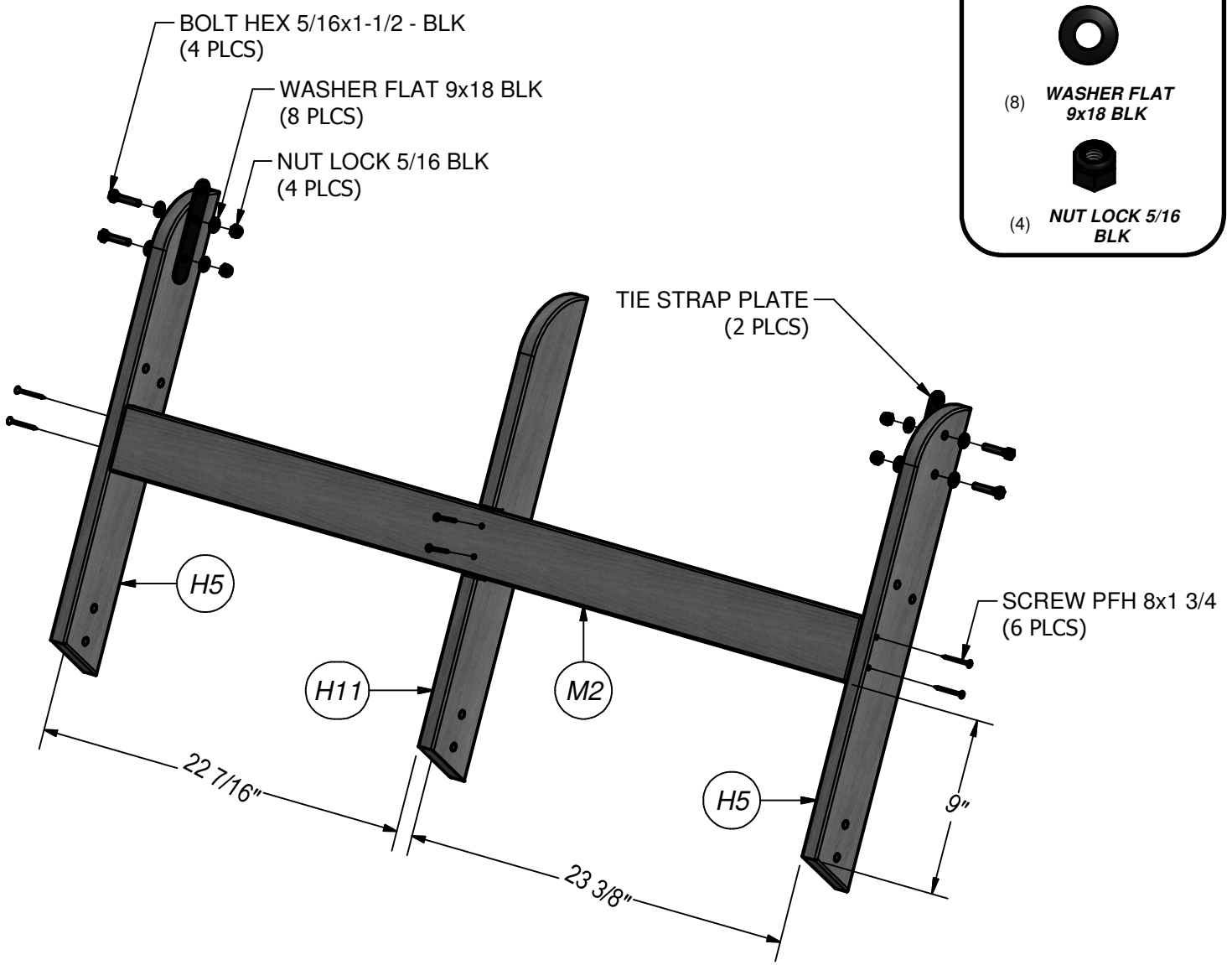

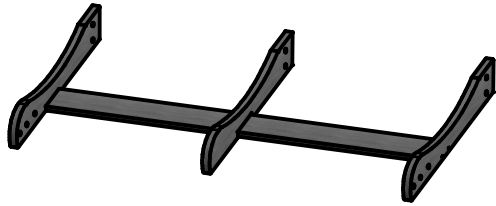

(1) SEAT ASSEMBLY

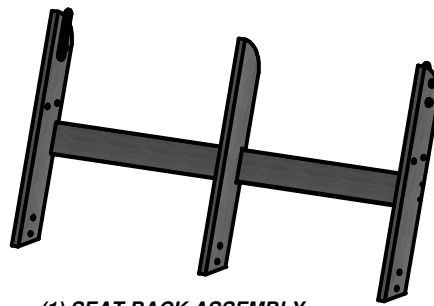

(1) SEAT BACK ASSEMBLY

**STEP 16**

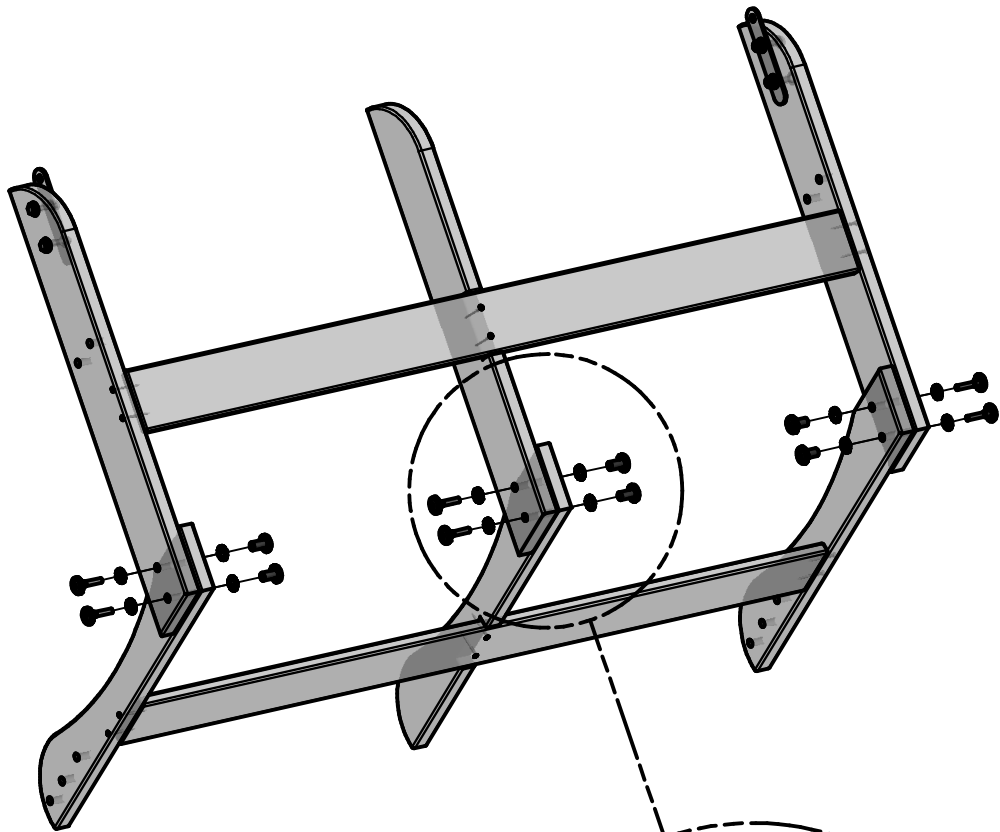

(6) WASHER LOCK  
EXT 12x19 BLK

(6) BOLT WH  
5/16x1 1/2 BLK

(6) WASHER LOCK  
EXT 8x19 BLK

(6) NUT BARREL  
WH 5/16x7/8  
BLK

- BOLT WH 5/16x1 1/2 BLK (6 PLCS)
- WASHER LOCK EXT 8x19 BLK (6 PLCS)
- NUT BARREL WH 5/16x7/8 BLK (6 PLCS)
- WASHER LOCK EXT 12x19 BLK (6 PLCS)

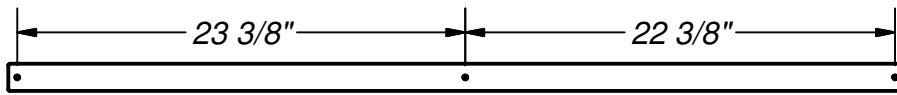

**T3 - SWING SEAT BOARD - W4L05543**  
 (12) 1"x1 3/8"x46 3/4" (24x36x1186)

**STEP 17**

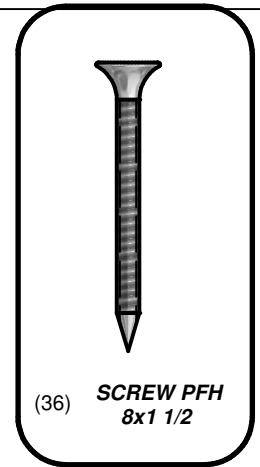
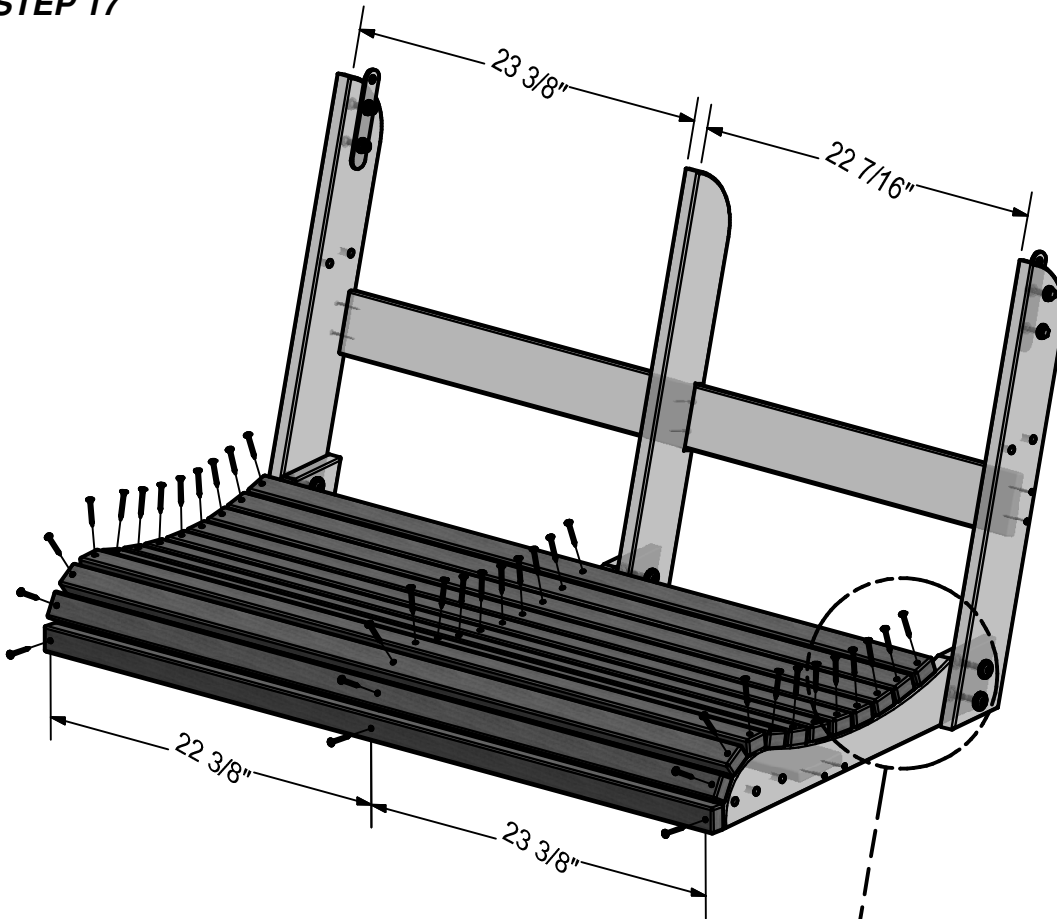

SCREW PFH 8x1 1/2  
(36 PLCS)

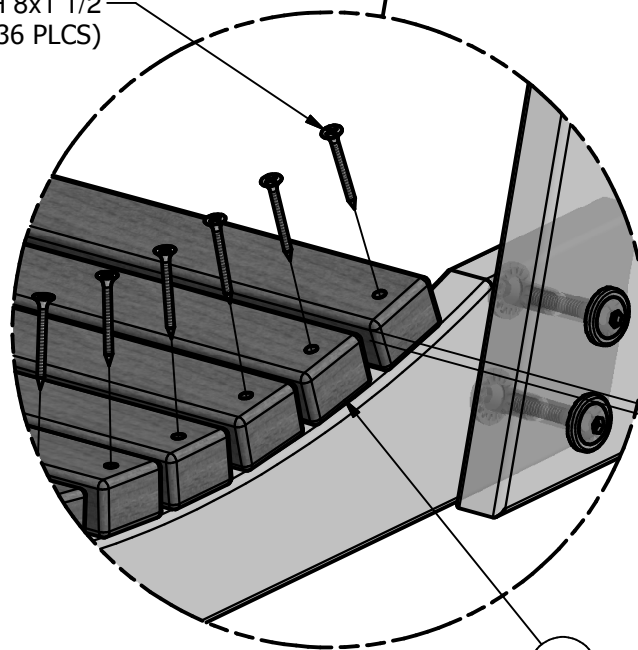

5/16"  
TYPICAL SPACING

T3

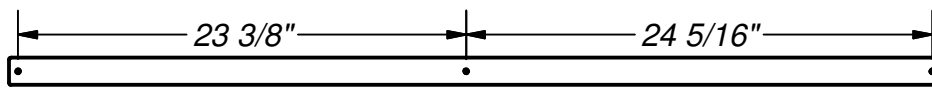

**T2 - SWING BACK BOARD - W4L05542**  
(10) 1"x1 3/8"x48 5/8" (24x36x1234)

**STEP 18**

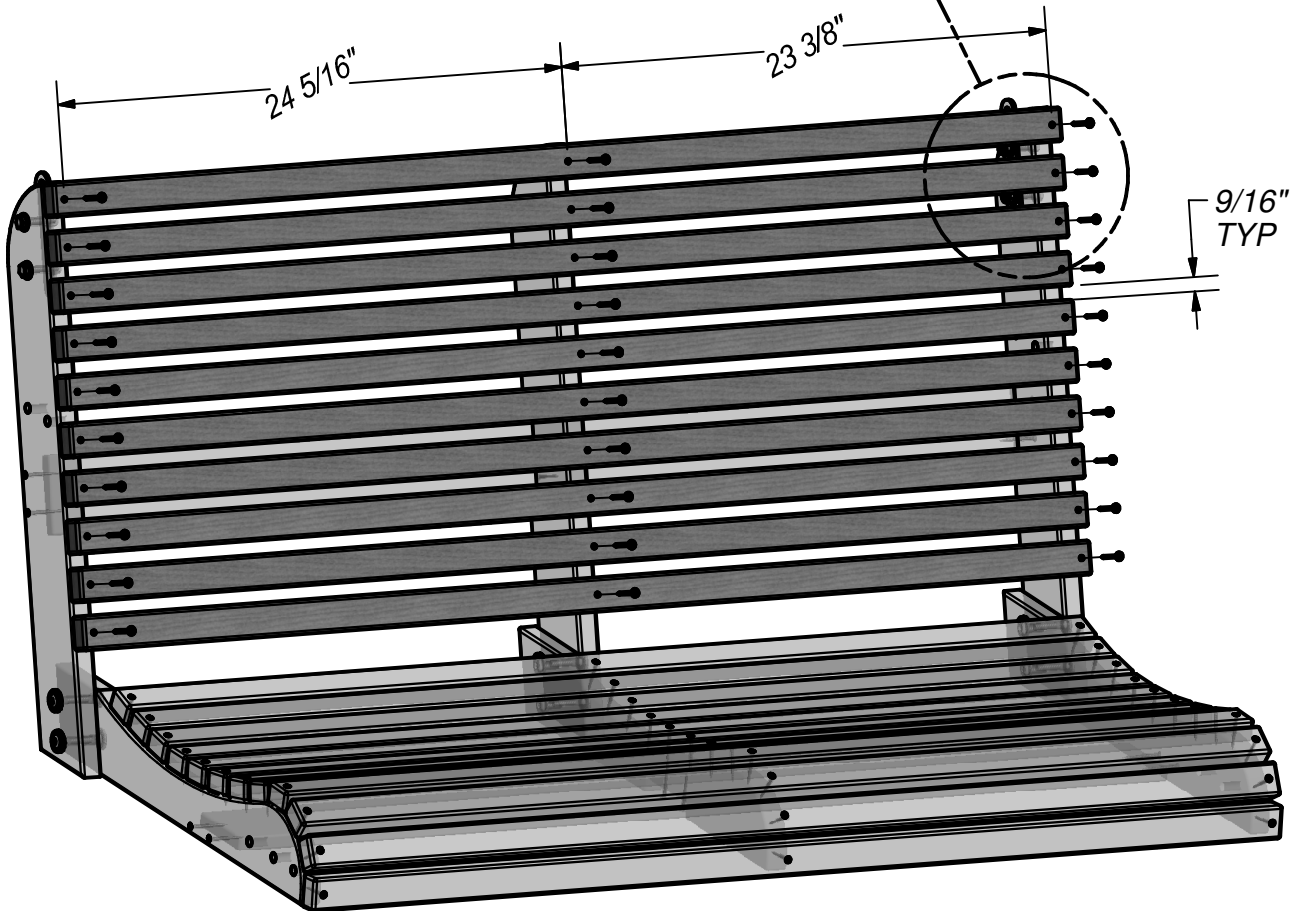
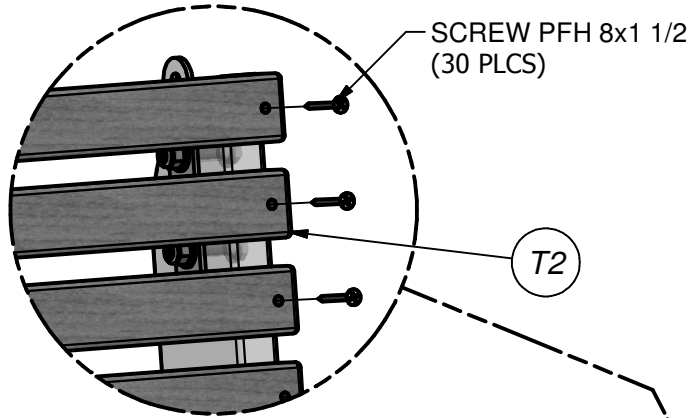
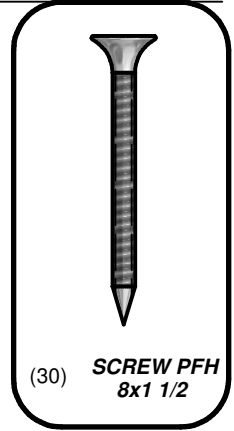



(1) **H10 - SWING RAIL SUPPORT - W4L05544**  
 1"x3 3/8"x13" (24x86x330)



(1) **E2 - RIGHT ARM REST - W4L05541**  
 1 3/8"x3 3/8"x26 5/8"(36x86x677)

(1) **- CHAIN SUPPORT BRACKET - A4M00632**

**STEP 19**

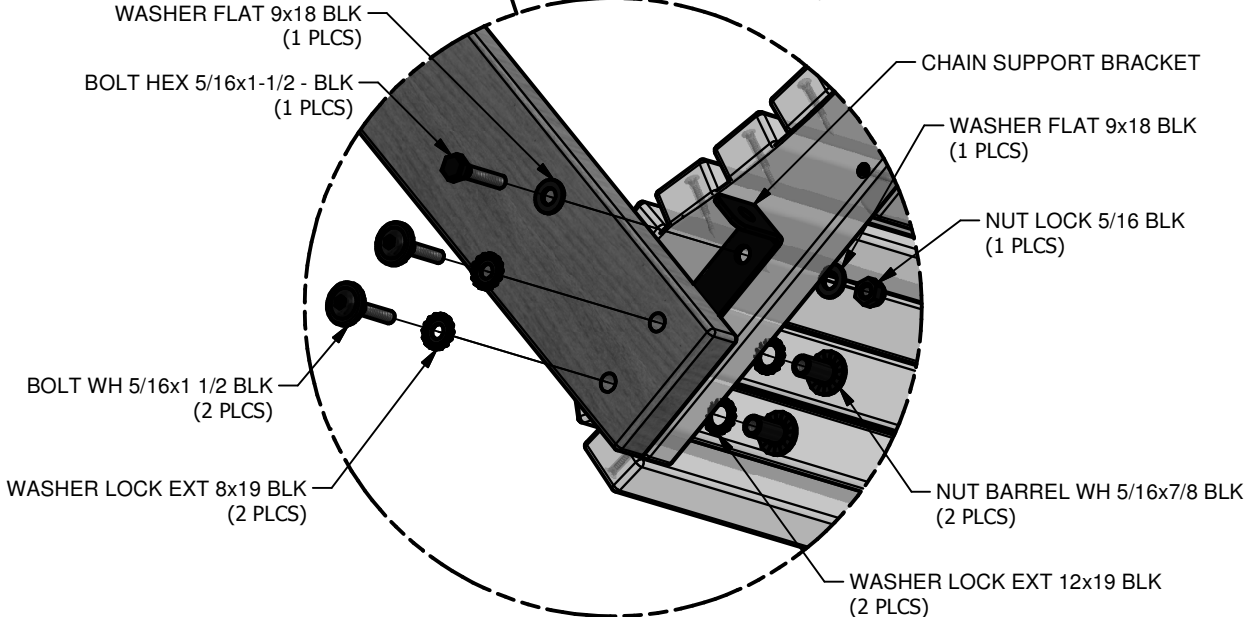
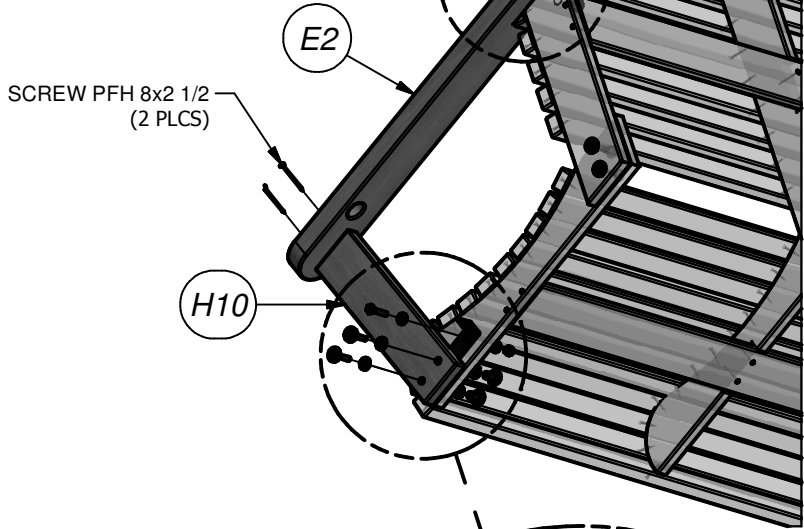
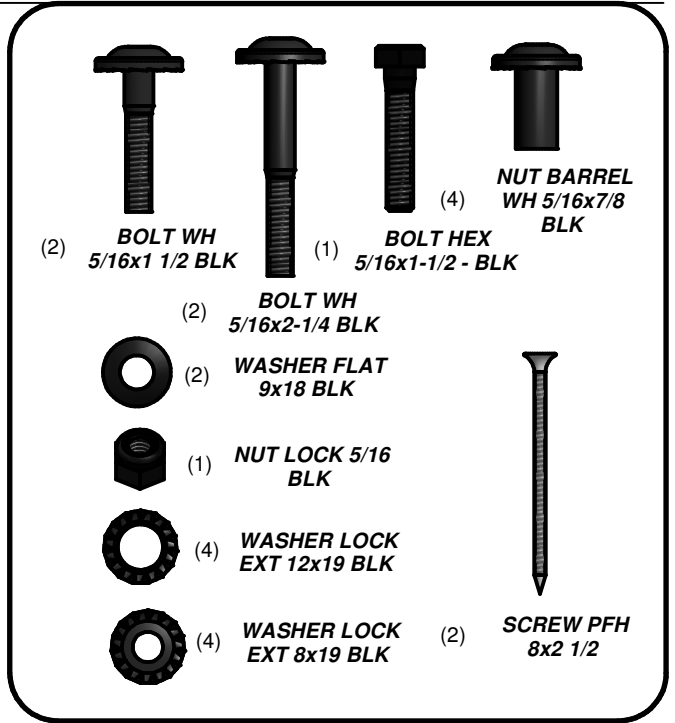
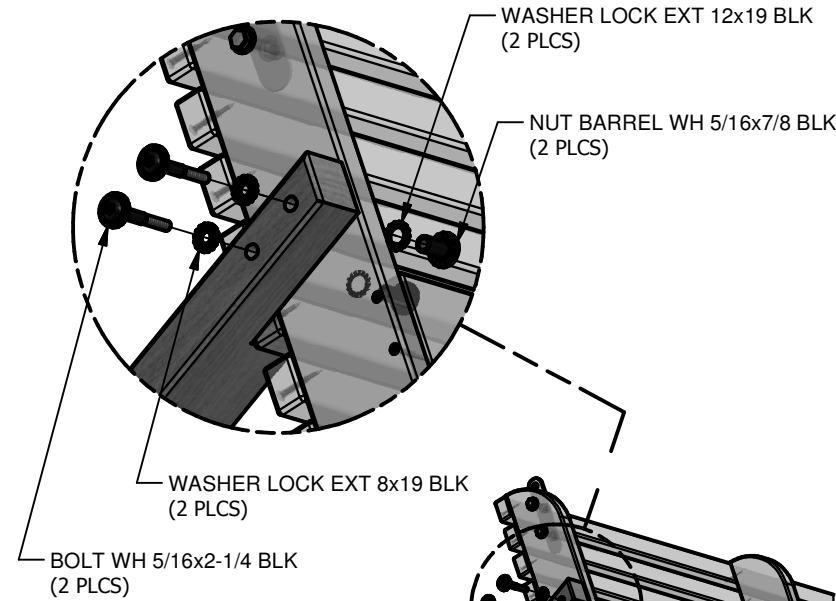



(1) **H10 - SWING RAIL SUPPORT - W4L05544**  
 1"x3 3/8"x13" (24x86x330)



(1) **E1 - LEFT ARM REST - W4L05540**  
 1 3/8"x3 3/8"x26 5/8" (36x86x677)

(1) - **CHAIN SUPPORT BRACKET - A4M00632**

**STEP 20**

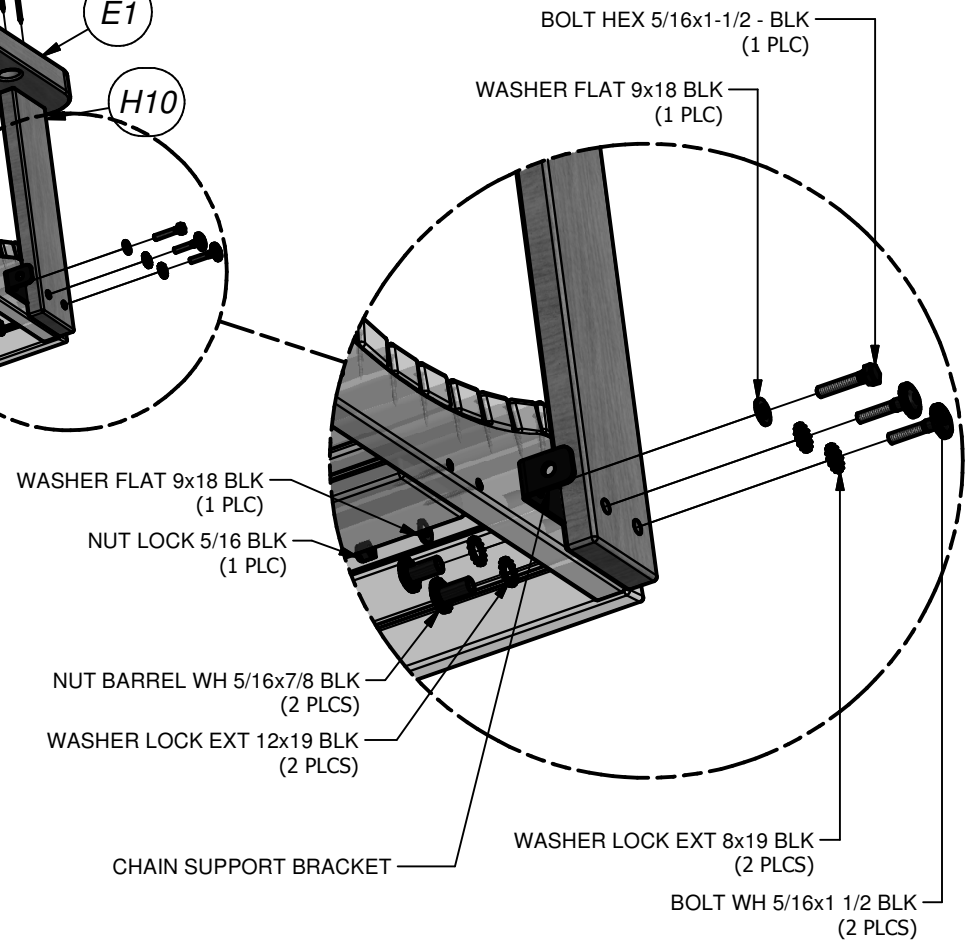
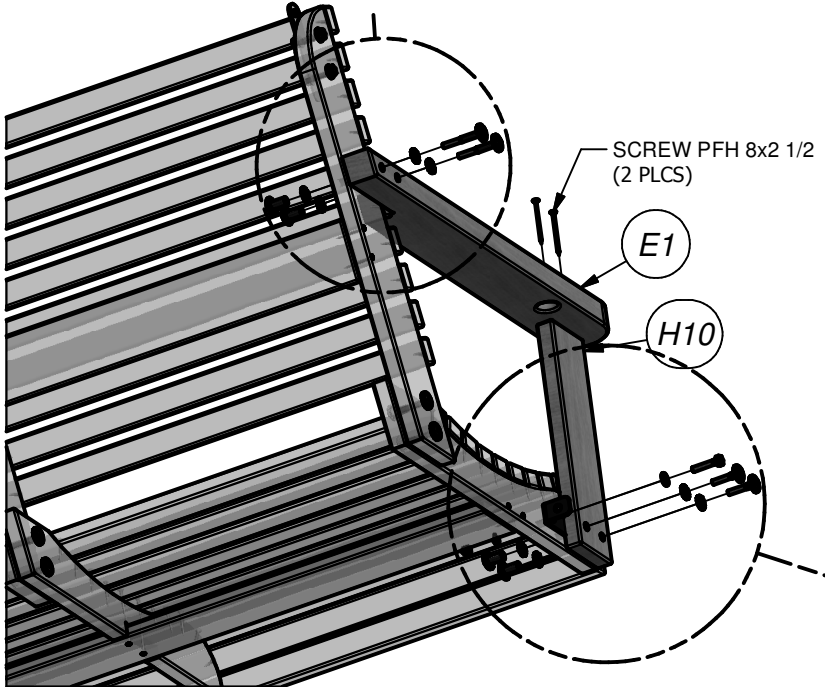
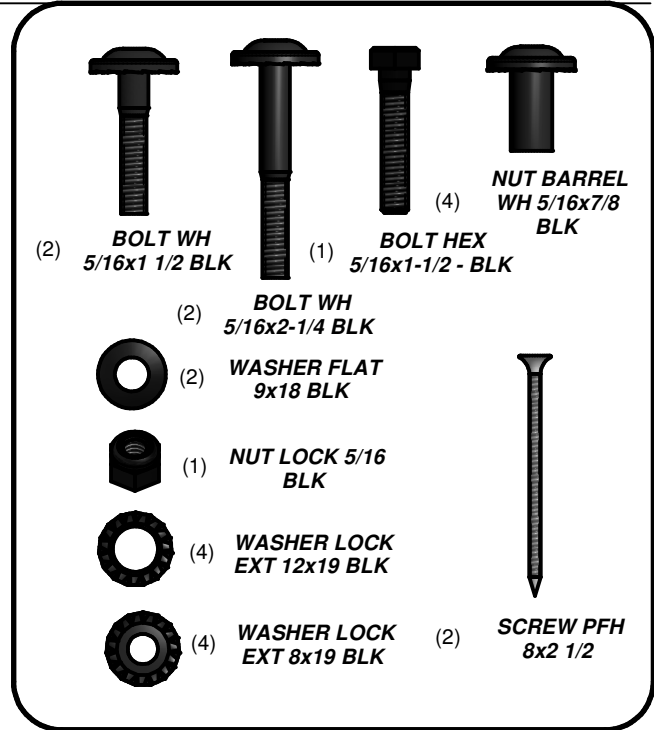
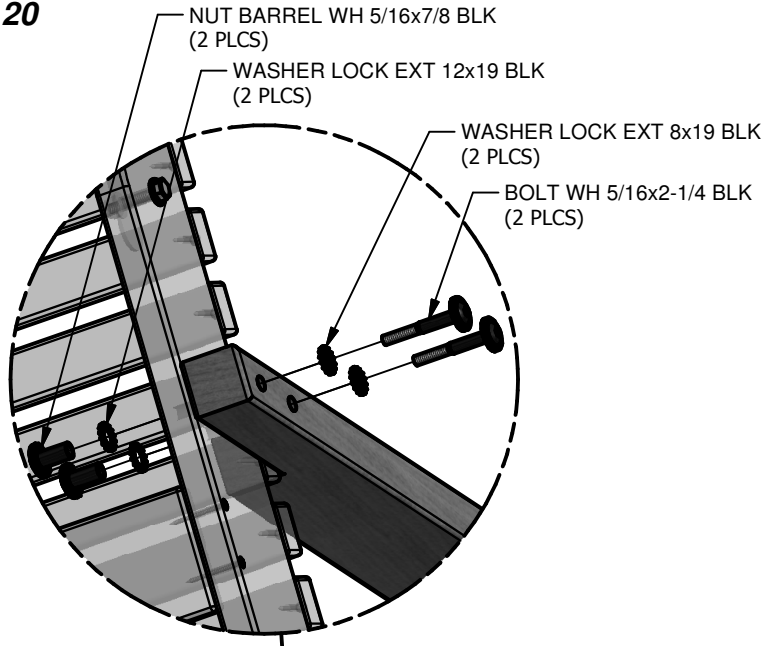

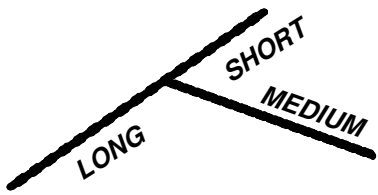

(2) - PERGOLA SWING CHAIN - A4M00634



(4) - QUICK LINK - A4M00633

(1) XR - BYD ID TAG (SMALL) WITHOUT AGES - A100241

STEP 21

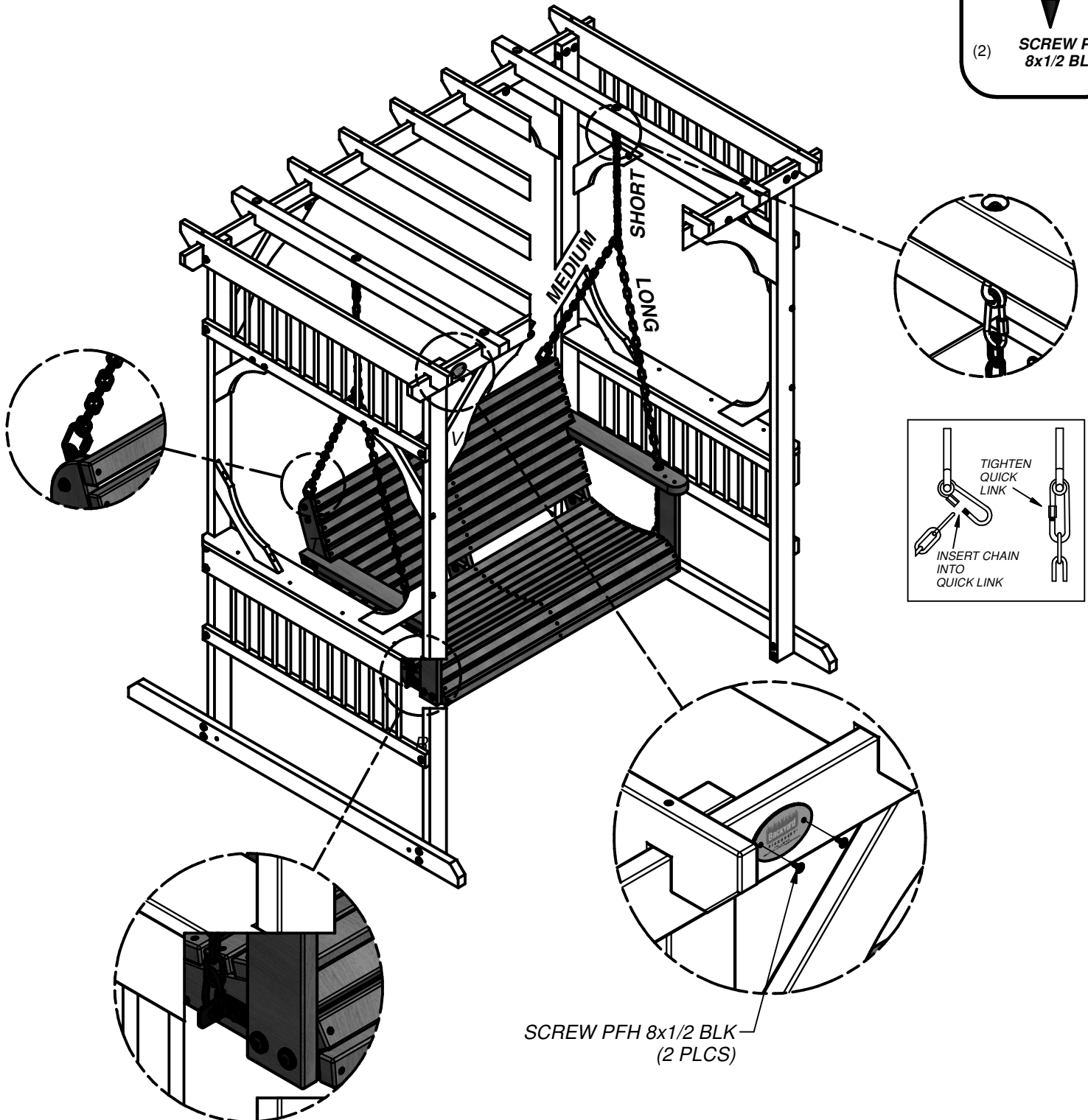
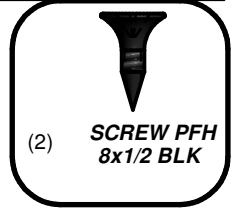

SCREW PFH 8x1/2 BLK  
(2 PLGS)



**STEP 22**

**INSTALLATION ON GRASS.**

**IF INSTALLING ON HARD SURFACE SKIP TO NEXT STEP.**

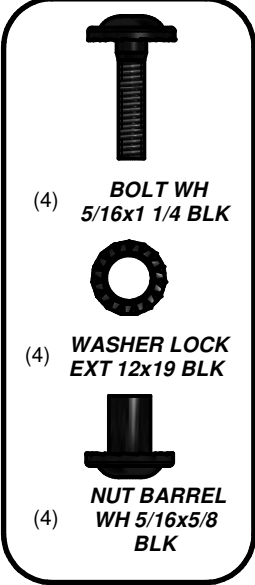
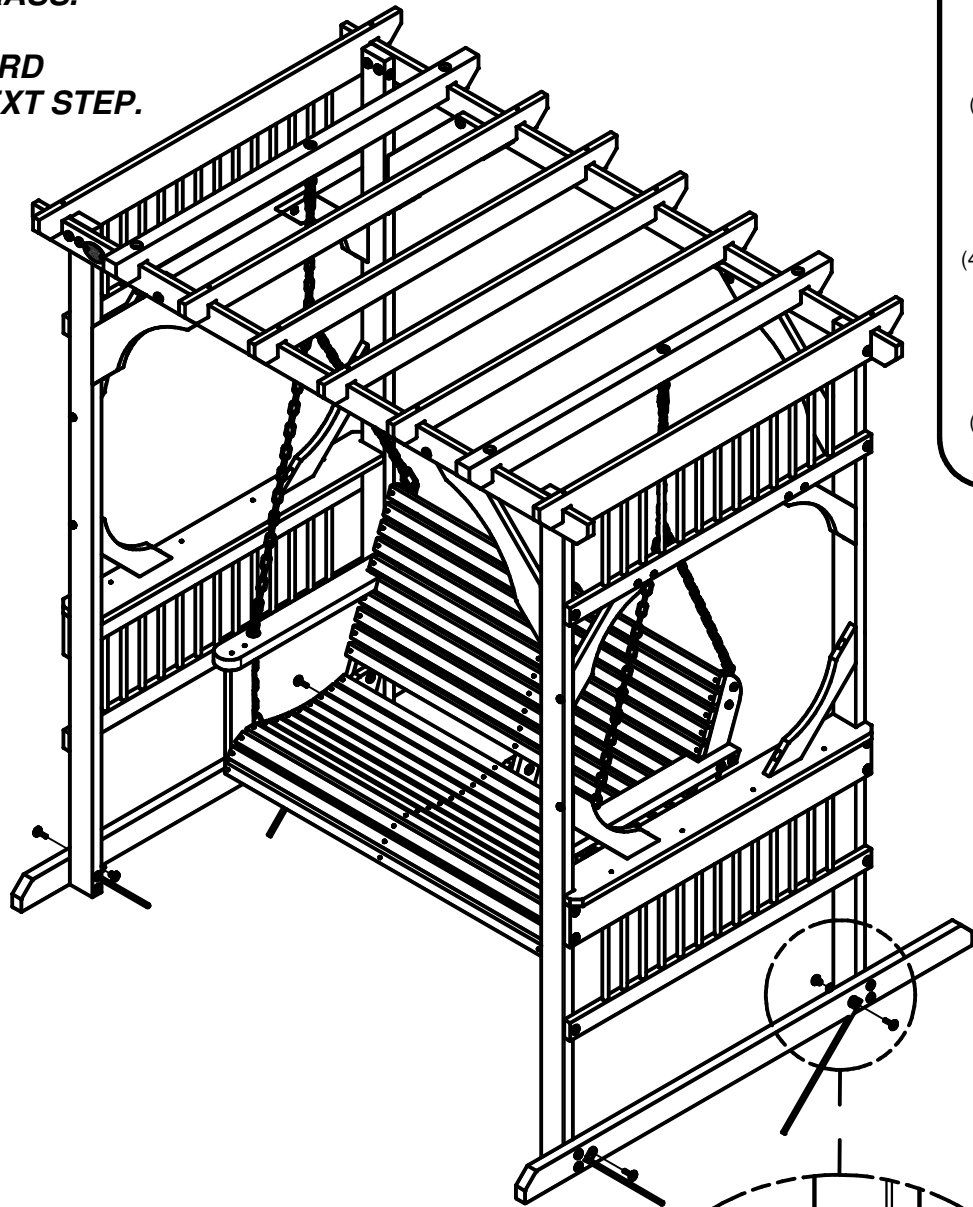

NUT BARREL WH 5/16x5/8 BLK  
(4 PLCS)

WASHER LOCK EXT 12x19 BLK  
(4 PLCS)

GROUND STAKE REBAR  
(4 PLCS)

BOLT WH 5/16x1 1/4 BLK  
(4 PLCS)



(4) - L BRACKET 2.5x38x50x55 - A4M00615

**STEP 23**

**PRE-DRILL HOLES FOR CONCRETE ANCHORS USING A 3/16" CONCRETE.**

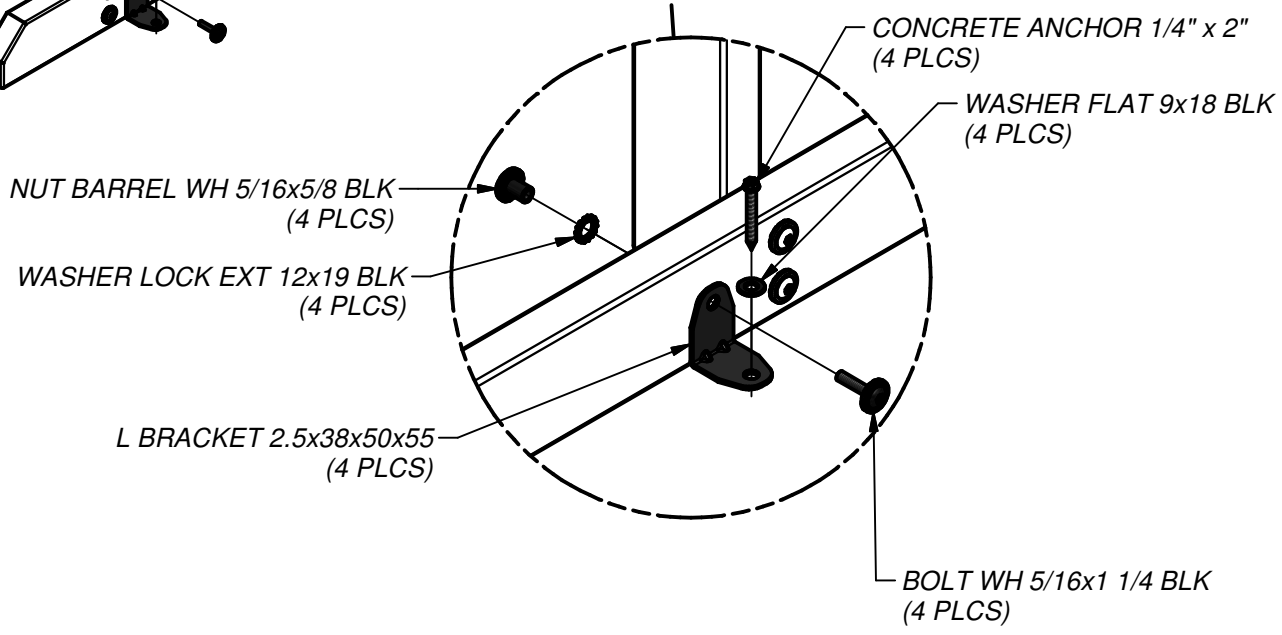
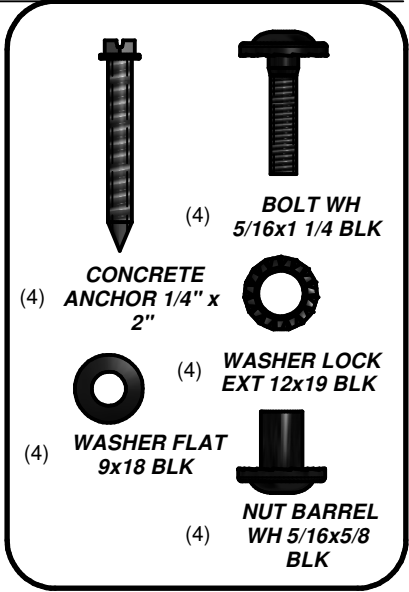
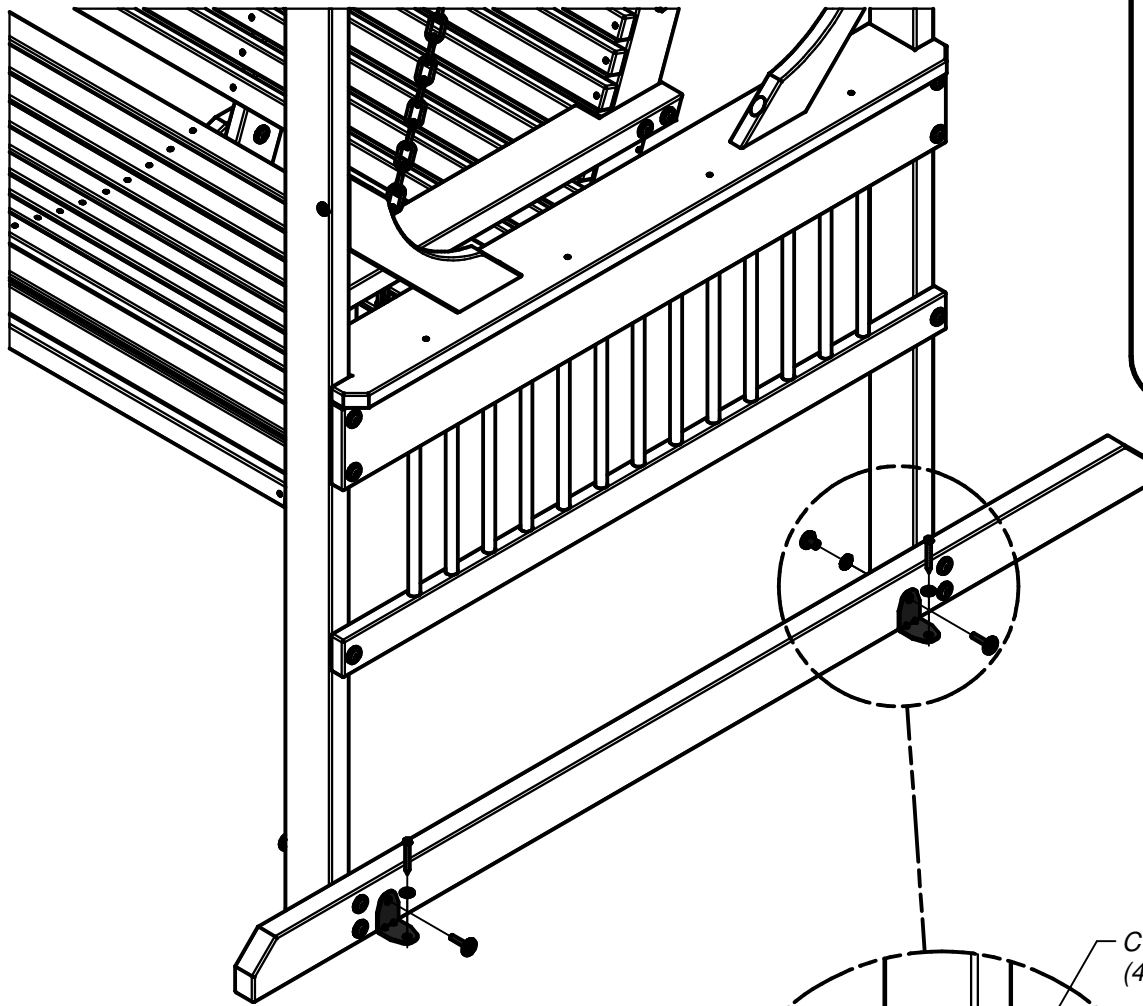



(1) SQ - "A" REVISION TAG - A100314

STEP 24

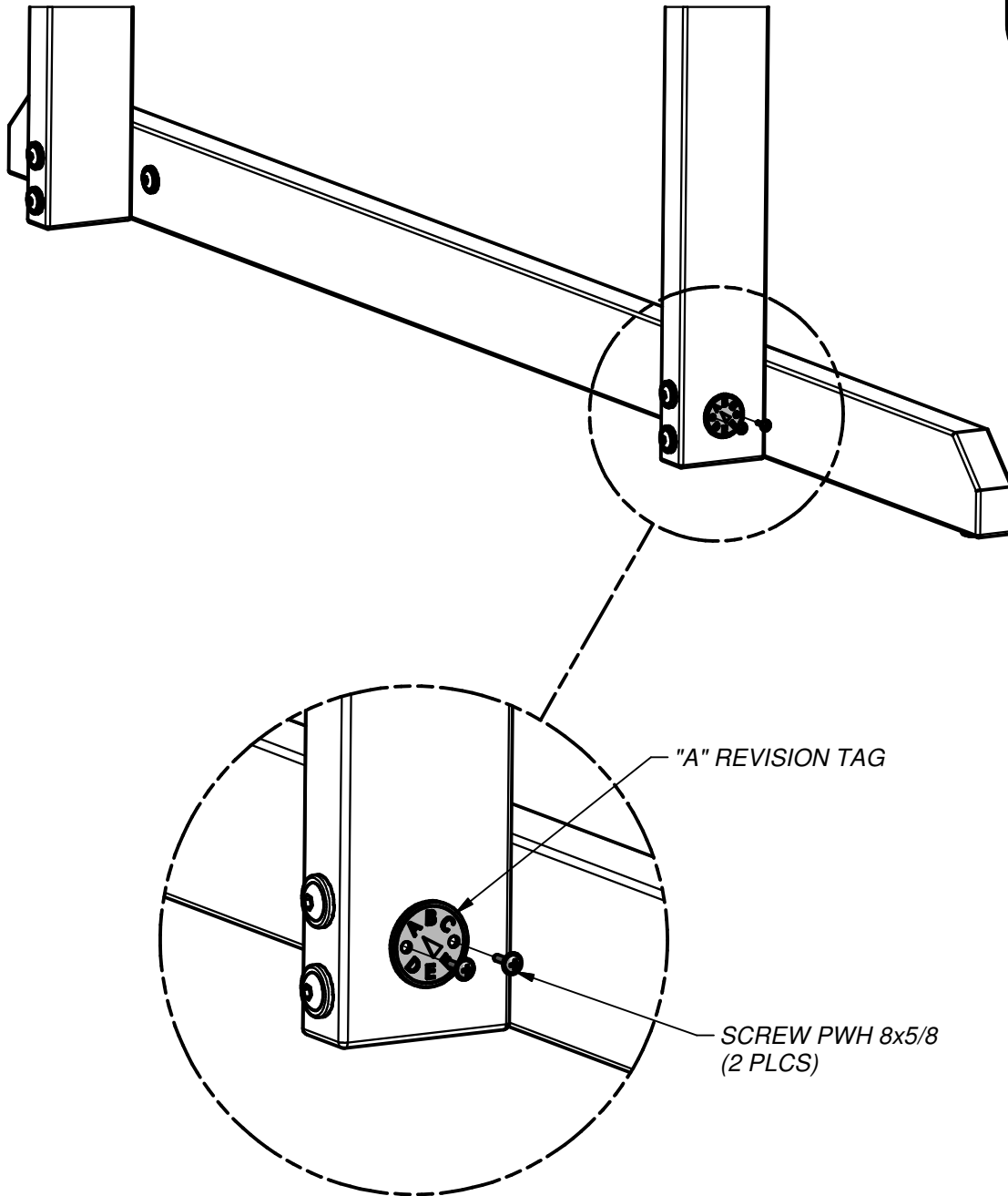
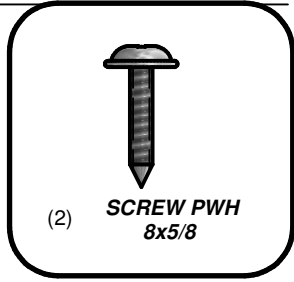

## Limited Warranty

This Limited Warranty by Backyard Discovery applies to products manufactured under the Backyard Discovery brand or its other brands including but not limited to Backyard Botanical, Adventure Playsets, and Leisure Time Products.

Backyard Discovery warrants that this product is free from defect in materials and workmanship for a period of one (1) year from the original date of purchase. This one (1) year warranty covers all parts including wood, hardware, and accessories. All wood carries a five (5) year pro-rated warranty against rot and decay. Refer to the schedule below for charges associated with replacement of parts under this Limited Warranty. In addition, Backyard Discovery will replace any parts within the first 30 days from date of purchase found to be missing from or damaged in the original packaging.

This warranty applies to the original owner and registrant and is **non-transferable**. Regular maintenance is required to assure maximum life and performance of this product and failure by the owner to maintain the product according to the maintenance requirements may void this warranty. Maintenance guidelines are provided in the Owner's Manual.

This Limited Warranty does not cover:

- Labor for any inspection
- Labor for replacement of any defective item(s)
- Incidental or consequential damages
- Cosmetic defects which do not affect performance or integrity of a part or the entire product
- Vandalism, improper use, failure due to loading or use beyond the capacities stated in the applicable Assembly Manual.
- Acts of nature including but not limited to wind, storms, hail, floods, excessive water exposure
- Improper installation including but not limited to installation on uneven, unlevel, or soft ground
- Minor twisting, warping, checking, or any other natural occurring properties of wood that do not affect performance or integrity

Backyard Discovery products have been designed for safety and quality. Any modifications made to the original product could damage the structural integrity of the unit leading to failure and possible injury. Modification voids any and all warranties and Backyard Discovery assumes no liability for any modified products or consequences resulting from failure of a modified product.

This product is warranted for RESIDENTIAL USE ONLY. Under no circumstance should a Backyard Discovery product be used in public settings. Such use may lead to product failure and potential injury. Any and all public use will void this warranty. Backyard Discovery disclaims all other representations and warranties of any kind, express or implied.

This Warranty gives you specific legal rights. You may have other rights as well which vary from state to state or province to province. This warranty excludes all consequential damages, however, some states do not allow the limitation or exclusion of consequential damages and therefore this limitation may not apply to you.

### Pro Rated Part Replacement Schedule

<u>Product Age</u>	<u>Customer Pays</u>
<b>All Parts</b>	
0-30 days from date of purchase	\$0 and free shipping
31 days to 1 year	\$0 + S&H
<b>Wood Rot and Decay Only</b>	
1 year	\$0 and free shipping
2 years	20% + S&H
3 years	40% + S&H
4 years	60% + S&H
5 years	80% + S&H
Over 5 years	100% + S&H