

HOME DECORATORS COLLECTION

INV# 74006
SK18210A1 WALKER CORNER BENCH 20"Hx30"Wx30"D
ASSEMBLY INSTRUCTIONS

Made In China

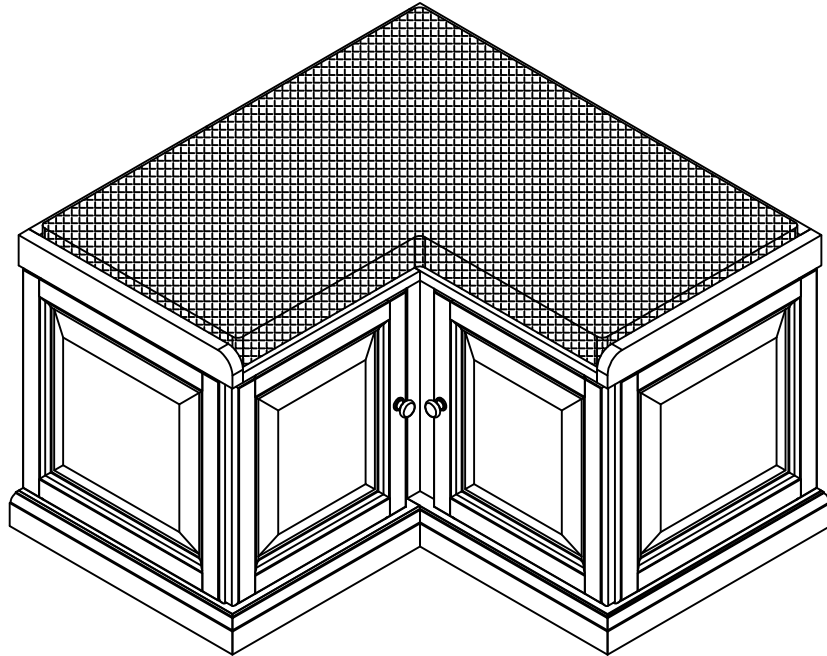

Thank you for purchasing this quality product. Be sure to check all packing material carefully for small parts, which may have come loose inside the carton during shipment. Count all parts and material hardware, then compare with parts list to be sure all parts are present. If any parts are missing or damaged, please contact our Customer Service Department for efficient and speedy service. Please indicate the model number and code letter of part(s) needed.

IMPORTANT NOTE: Follow instructions listed below in proper sequence as numbered to assure fast, easy and correct assembly.

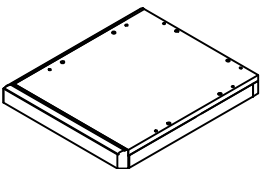
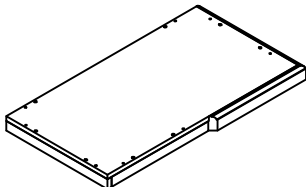
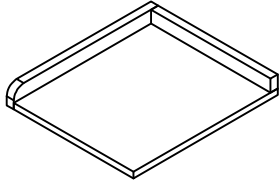
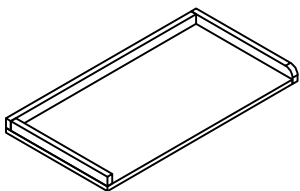
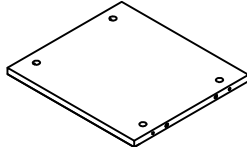
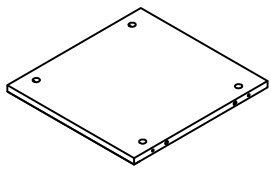
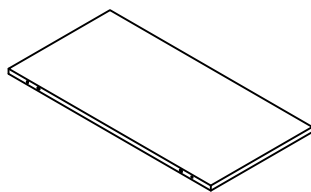
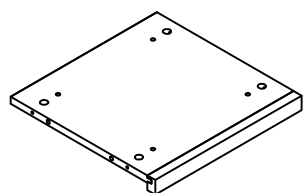
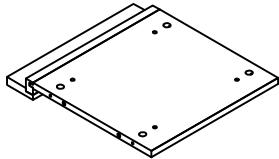
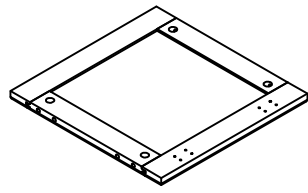
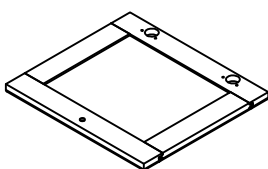
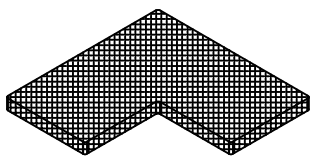
PARTS LIST		
A  LEFT SIDE BOTTOM PANEL-1PC	B  RIGHT SIDE BOTTOM PANEL-1PC	C  LEFT SIDE TOP PANEL-1PC
D  RIGHT SIDE TOP PANEL-1PC	E  LEFT SIDE BACK PANEL-1PC	F  RIGHT SIDE BACK PANEL-1PC
G  SIDE PANEL-1PC	H  LEFT SIDE MIDDLE PANEL-1PC	I  RIGHT SIDE MIDDLE PANEL-1PC
J  FRONT PANEL -2PCS	K  DOOR -2PCS	L  CUSHION-1PC

a



WOOD DOWEL-28PCS

b

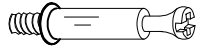

CAM
LOCK BOLT-28PCS

c



CAM LOCK-28PCS

d

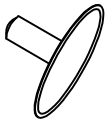

PLASTIC COVER-8PCS

e

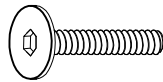

BOLT-4PCS

f

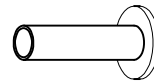

BINDING SCREW-4PCS

g



KNOB BOLT-2PCS

h

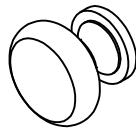

KNOB-2PCS

i



5/8" FLAT
HEAD SCREW-24PCS

j

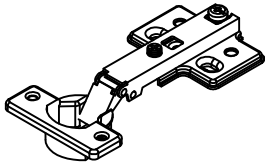

HINGE-4PCS

K



ALLEN WRENCH -2PCS

NOTE:THE SURFACE WITH THE STICKER IS THE BACK SIDE

NOTE: • UPON OPENING, THOROUGHLY CLEAN ALL WOOD SURFACES TO REMOVE DUST AND DIRT THAT MAY HAVE SETTLED ONTO THE FINISH DURING SHIPMENT. IN ORDER TO PREVENT DAMAGE DURING ASSEMBLY. PLEASE ASSEMBLE THIS ITEM WITH AT LEAST TWO PEOPLE.

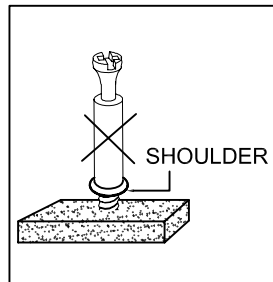
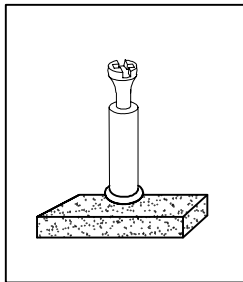

NOTE: TURN THE CAM-BOLT SCREWS UNTIL THEY ARE TIGHT, THE SHOULDER SHOULD BE AGAINST THE SURFACE OF THE PART.

HOW TO USE THE CAM-TOOL

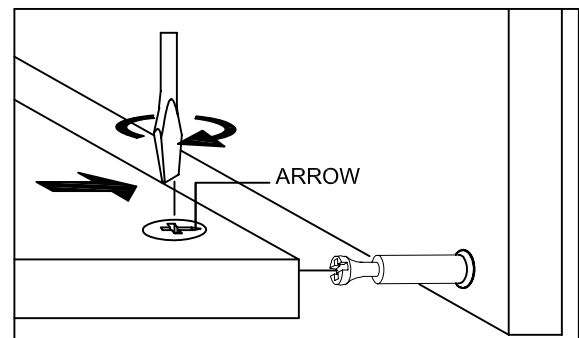
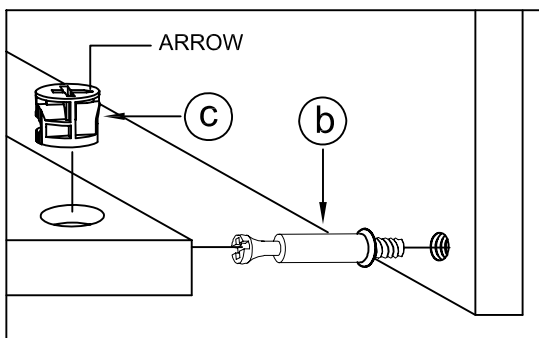

NOTE: • THE ARROWS ON THE HIDDEN CAM-LOCKS SHOULD POINT TO THE CAM-BOLTS.

FIG 1

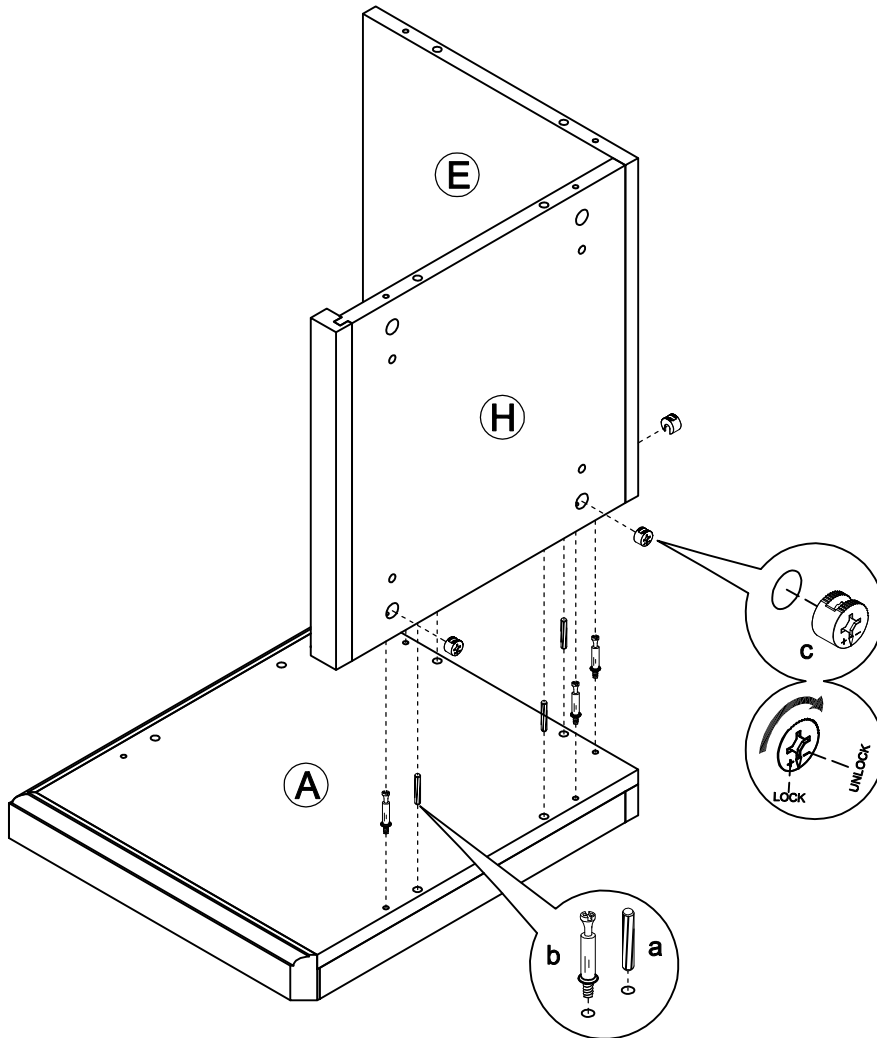

- INSTALL THE WOOD DOWEL (a) AND THE CAM LOCK BOLT (b) INTO THE LEFT SIDE BOTTOM PANEL (A).
- JOIN THE LEFT SIDE BACK PANEL (E) AND THE LEFT SIDE MIDDLE PANEL (H) TO THE LEFT SIDE BOTTOM PANEL (A) BY USING WOOD DOWEL (a) FIRST.
- TIGHTEN THE CAM LOCK BOLT (b) WITH THE CAM LOCK (c) FROM PRE-DRILLED HOLES.

FIG 2

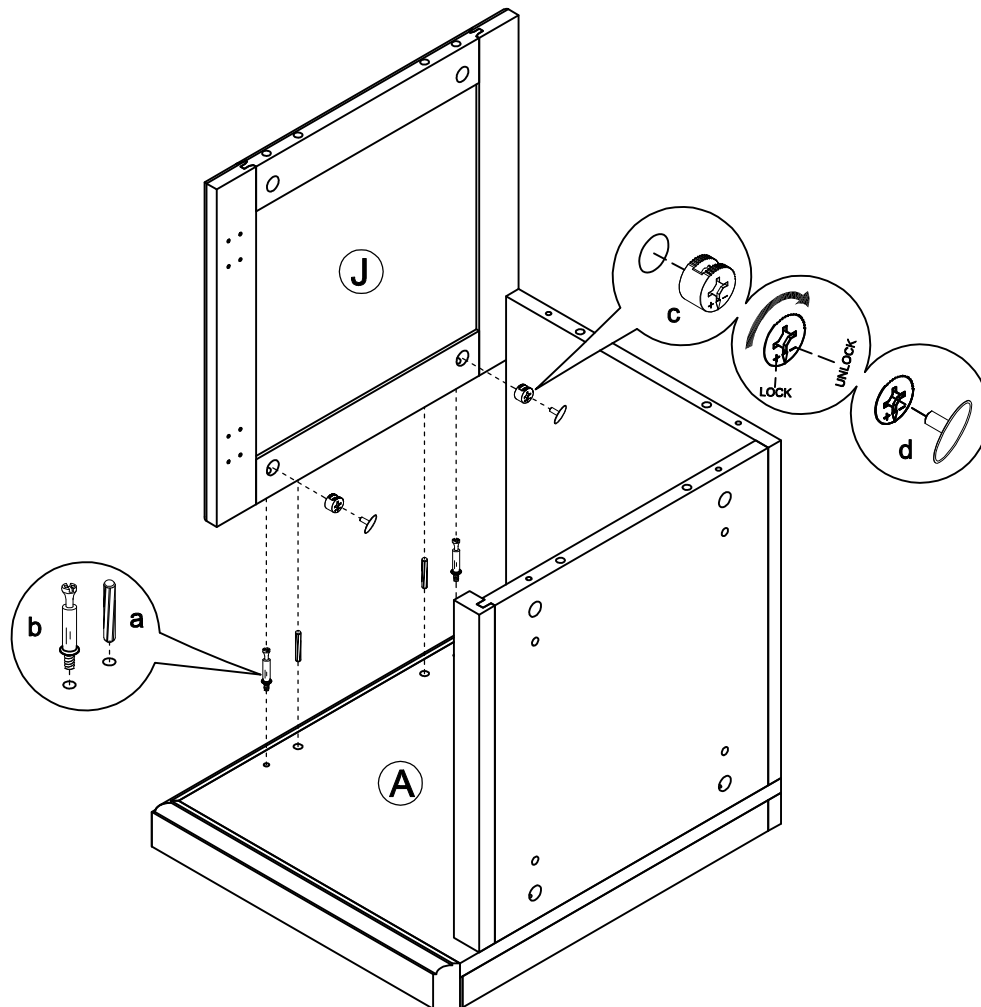

- INSTALL THE WOOD DOWEL (a) AND THE CAM LOCK BOLT (b) INTO THE LEFT SIDE BOTTOM PANEL (A).
- JOIN THE FRONT PANEL (J) TO THE LEFT SIDE BOTTOM PANEL (A) BY USING WOOD DOWEL (a) FIRST.
- TIGHTEN THE CAM LOCK BOLT (b) WITH THE CAM LOCK (c) FROM PRE-DRILLED HOLES.
- COVER THE CAM HOLES WITH PLASTIC COVER (d).

FIG 3

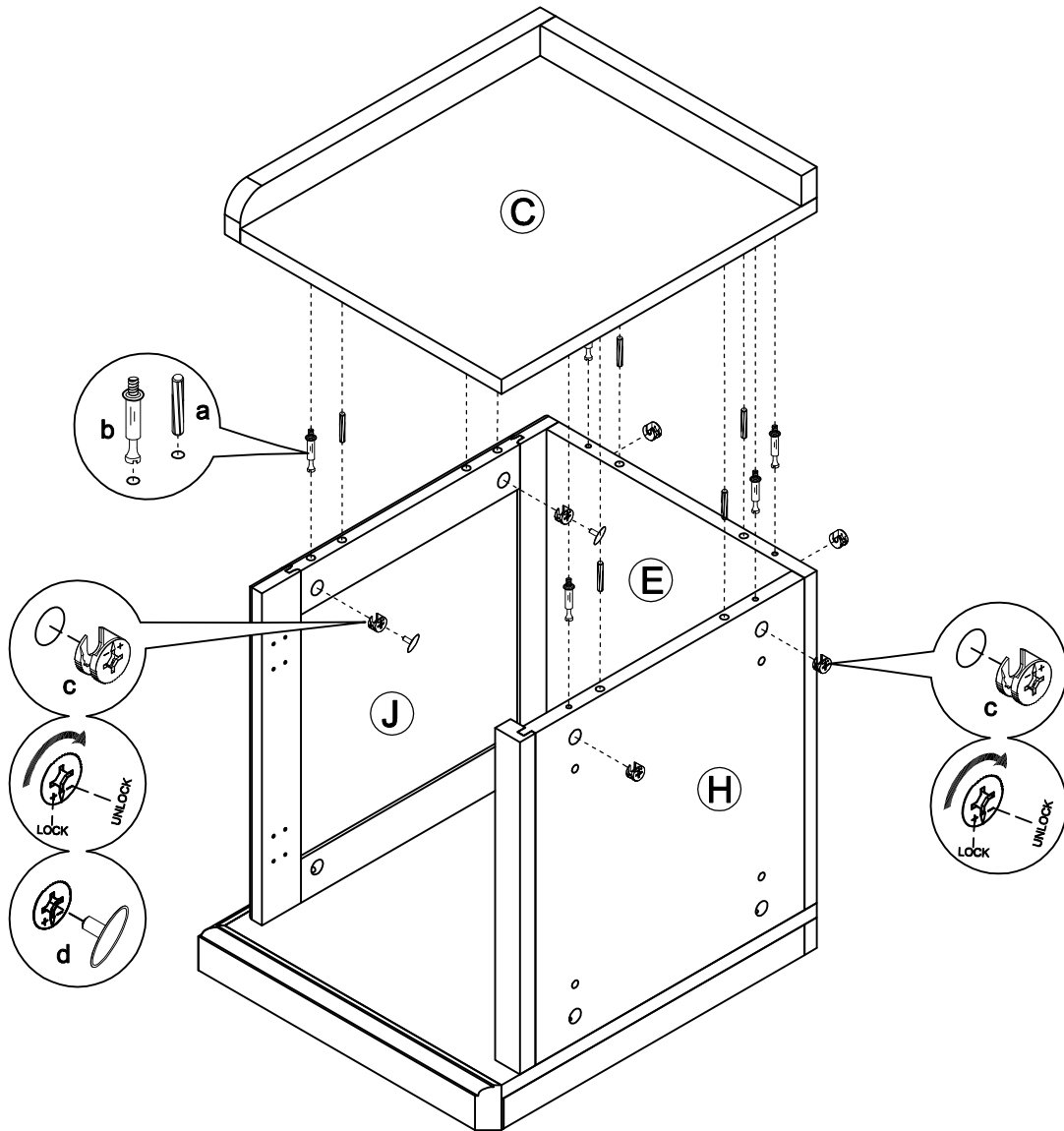

- INSTALL THE WOOD DOWEL (a) AND THE CAM LOCK BOLT (b) INTO THE LEFT SIDE TOP PANEL (C).
- JOIN THE LEFT SIDE TOP PANEL (C) TO THE LEFT SIDE BACK PANEL (E) THE LEFT SIDE MIDDLE PANEL (H) AND THE FRONT PANEL (J) BY USING WOOD DOWEL (a) FIRST.
- TIGHTEN THE CAM LOCK BOLT (b) WITH THE CAM LOCK (c) FROM PRE-DRILLED HOLES.
- COVER THE CAM HOLES WITH PLASTIC COVER (d).

FIG 4

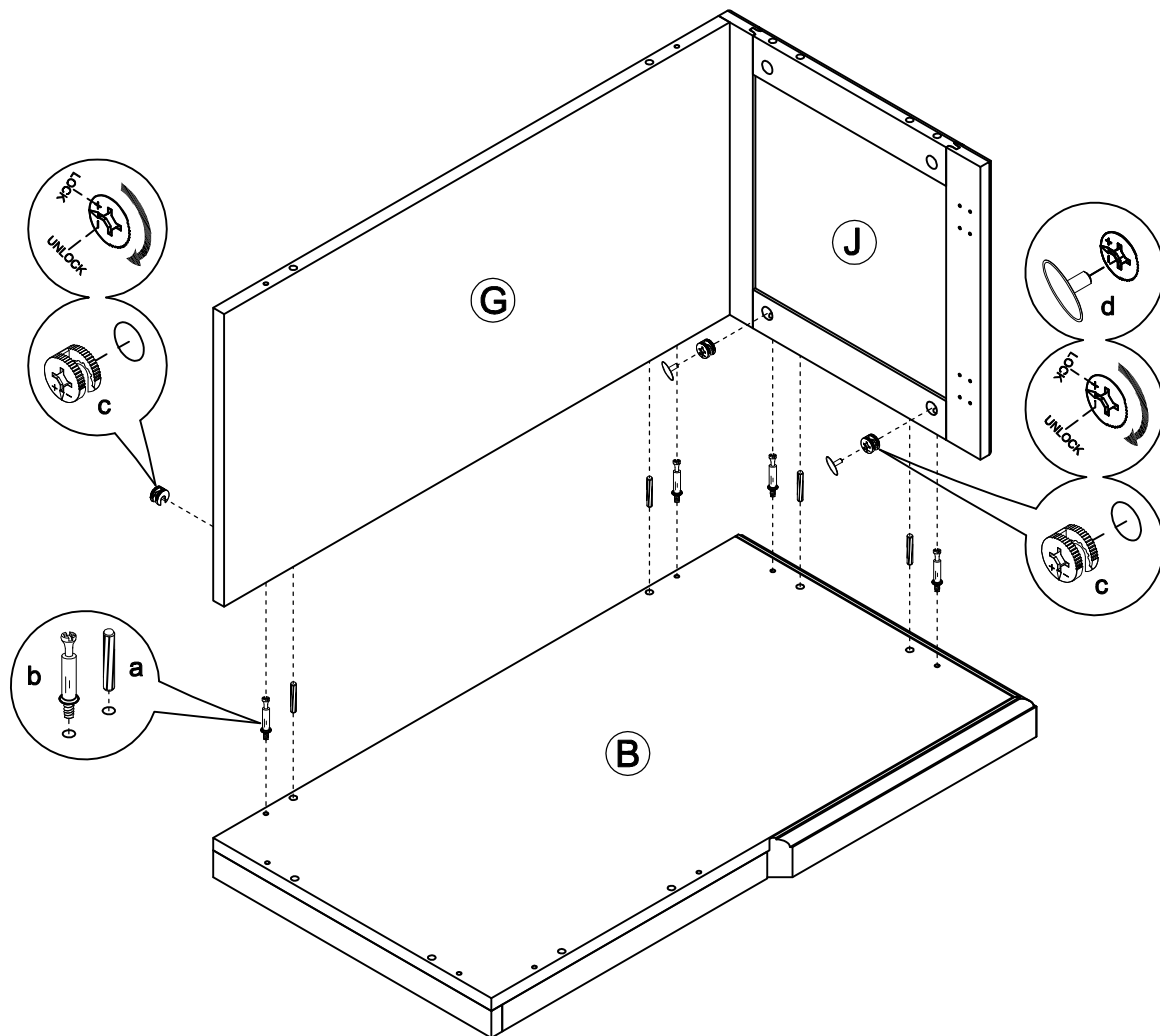

- INSTALL THE WOOD DOWEL (a) AND THE CAM LOCK BOLT (b) INTO THE RIGHT SIDE BOTTOM PANEL (B).
- JOIN THE RIGHT SIDE PANEL (G) AND THE FRONT PANEL (J) TO THE RIGHT SIDE BOTTOM PANEL (B) BY USING WOOD DOWEL (a) FIRST.
- TIGHTEN THE CAM LOCK BOLT (b) WITH THE CAM LOCK (c) FROM PRE-DRILLED HOLES.
- COVER THE CAM HOLES WITH PLASTIC COVER (d).

FIG 5

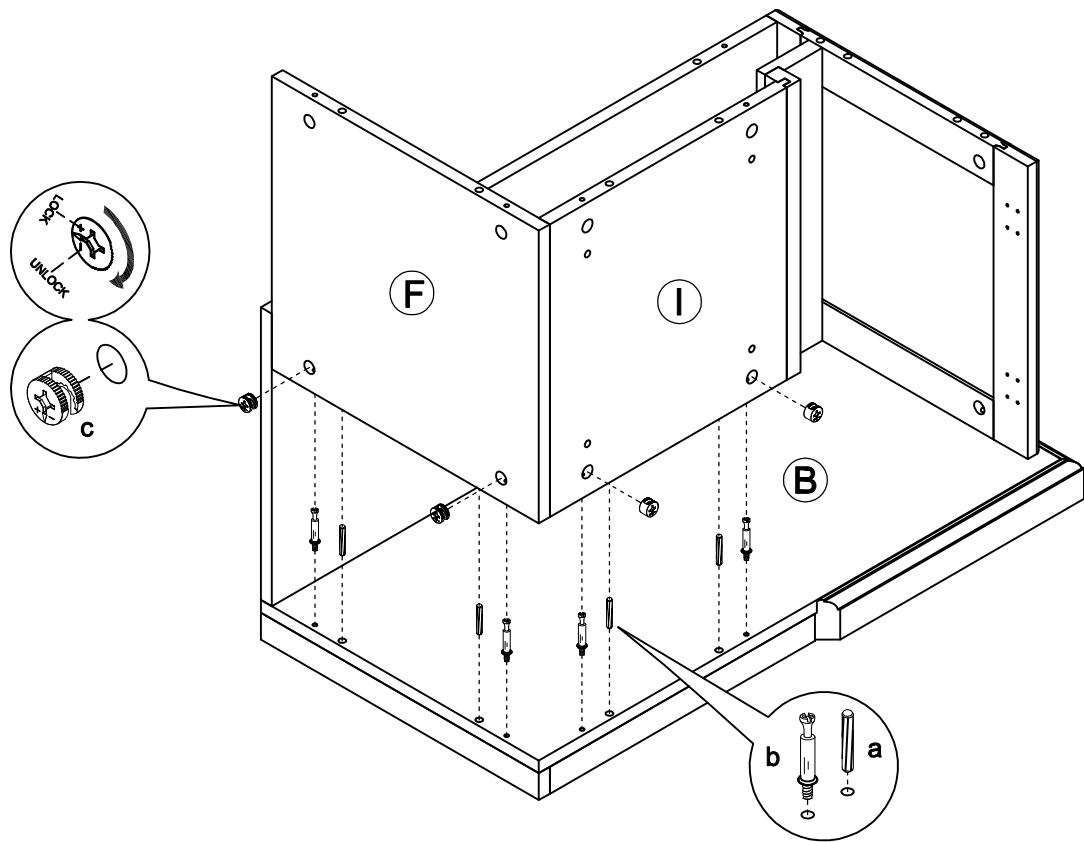

- INSTALL THE WOOD DOWEL (a) AND THE CAM LOCK BOLT (b) INTO THE RIGHT SIDE BOTTOM PANEL (B).
- JOIN THE RIGHT SIDE BACK PANEL (F) AND THE RIGHT SIDE MIDDLE PANEL (I) TO THE RIGHT SIDE BOTTOM PANEL (B) BY USING WOOD DOWEL (a) FIRST.
- TIGHTEN THE CAM LOCK BOLT (b) WITH THE CAM LOCK (c) FROM PRE-DRILLED HOLES.

FIG 6

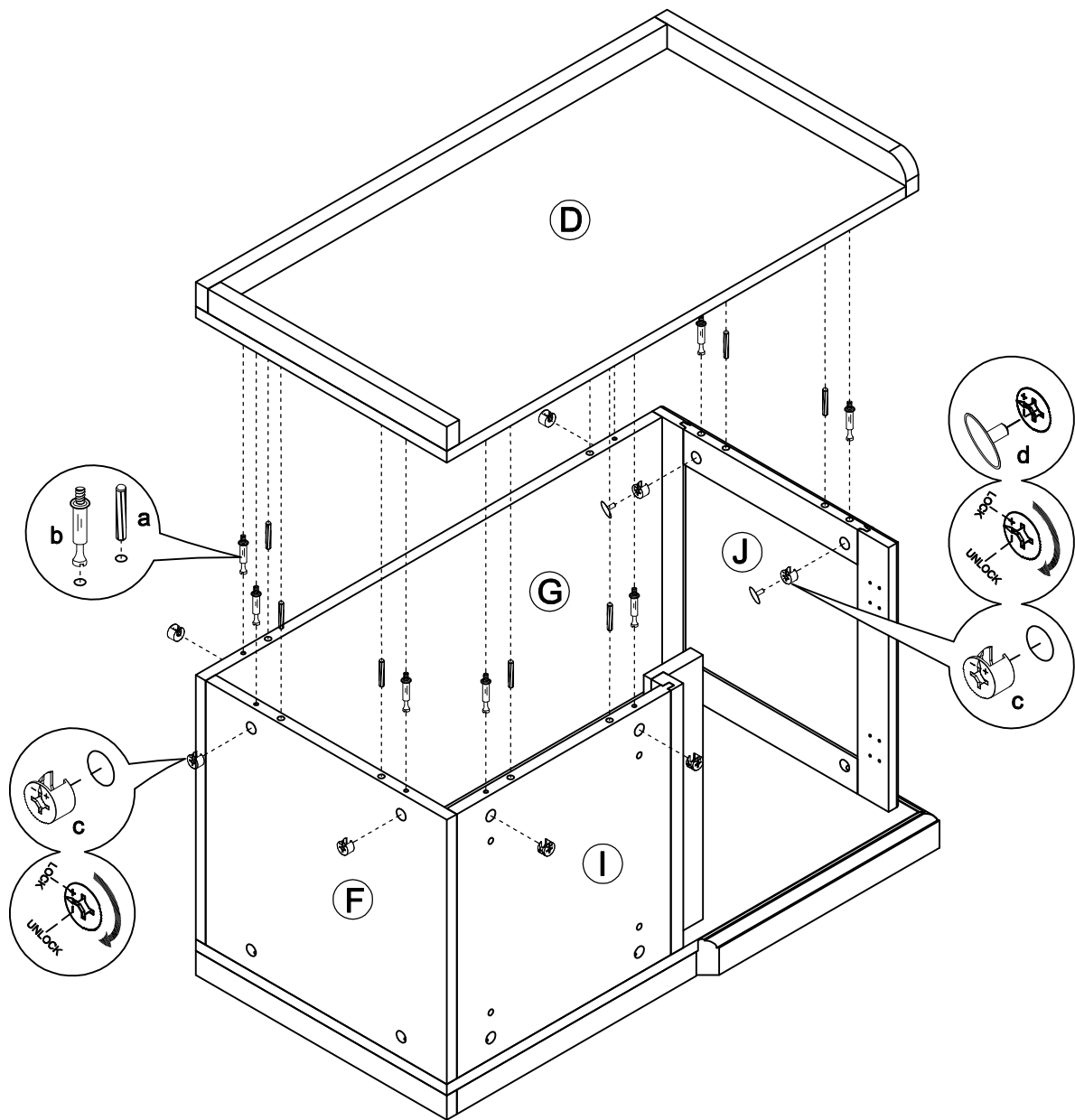

- INSTALL THE WOOD DOWEL (a) AND THE CAM LOCK BOLT (b) INTO THE RIGHT SIDE TOP PANEL (D).
- JOIN THE RIGHT SIDE TOP PANEL (D) TO THE RIGHT SIDE BACK PANEL (F) THE RIGHT SIDE MIDDLE PANEL (I) THE RIGHT SIDE PANEL (G) AND THE FRONT PANEL (J) BY USING WOOD DOWEL (a) FIRST.
- TIGHTEN THE CAM LOCK BOLT (b) WITH THE CAM LOCK (c) FROM PRE-DRILLED HOLES.
- COVER THE CAM HOLES WITH PLASTIC COVER (d).

FIG 7

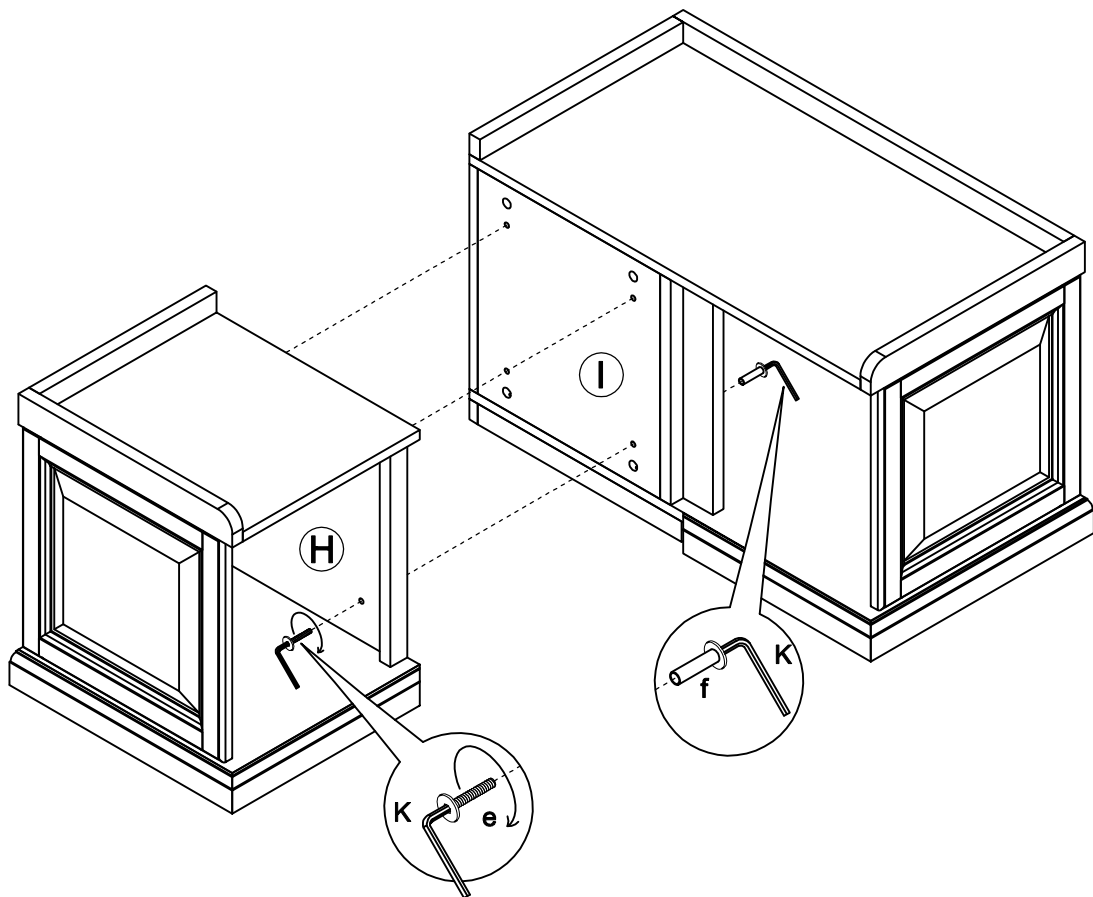

- JOIN THE TWO ASSEMBLED BASE PARTS BY USING BOLT (e) THE BINDING SCREW (f) AND THE ALLEN WRENCH (k) FIRST.

FIG 8

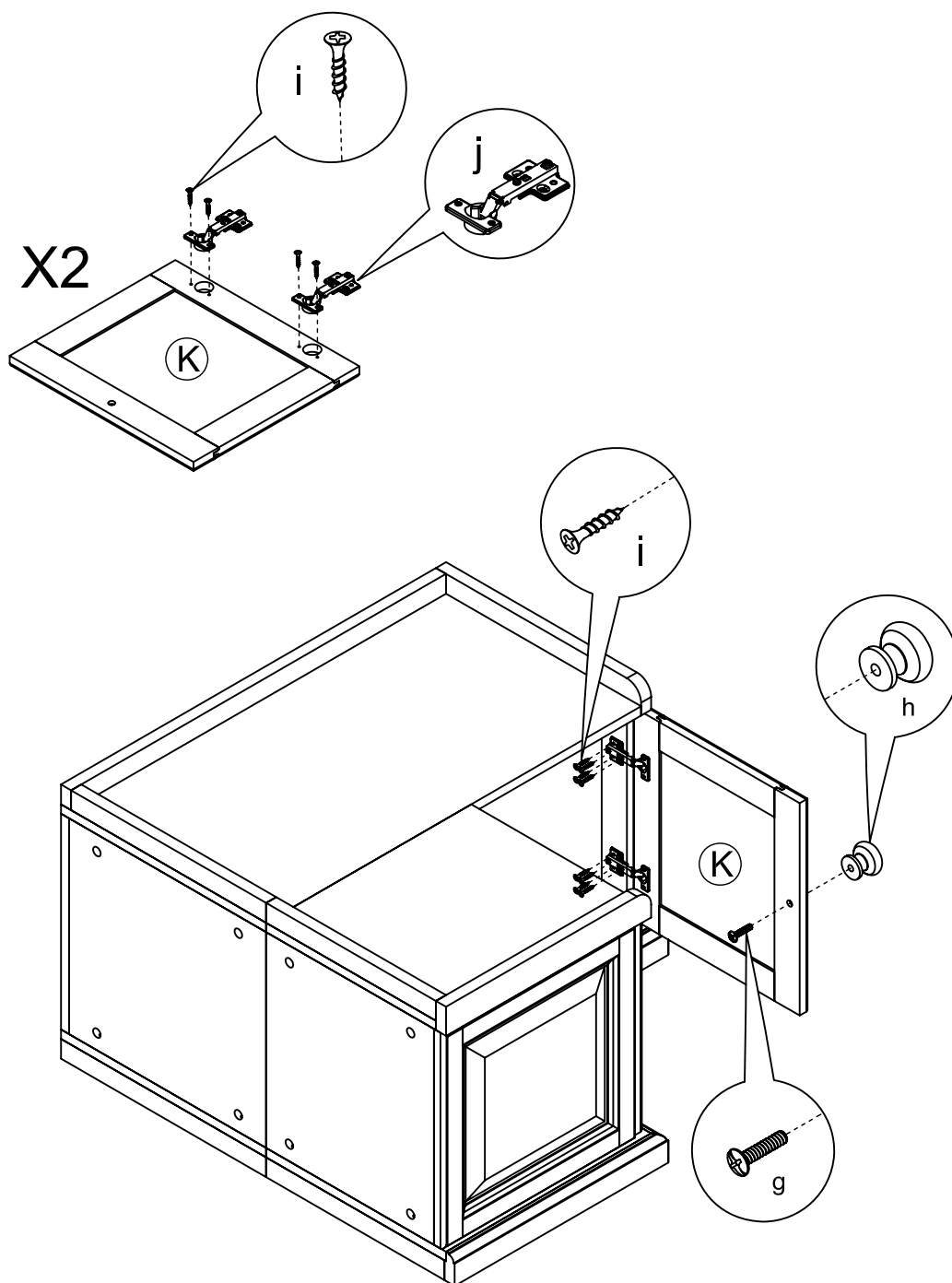

- ATTACH THE HINGE (j) TO THE DOOR (K) BY USING THE 5/8" FLAT HEAD SCREW (i).
- ATTACH THE DOOR (K) TO THE ASSEMBLED PART BY USING THE 5/8" FLAT HEAD SCREW (i).
- TIGHTEN THE KNOB (h) ONTO THE DOOR (K) BY USING THE KNOB BOLT (g).

FIG 9

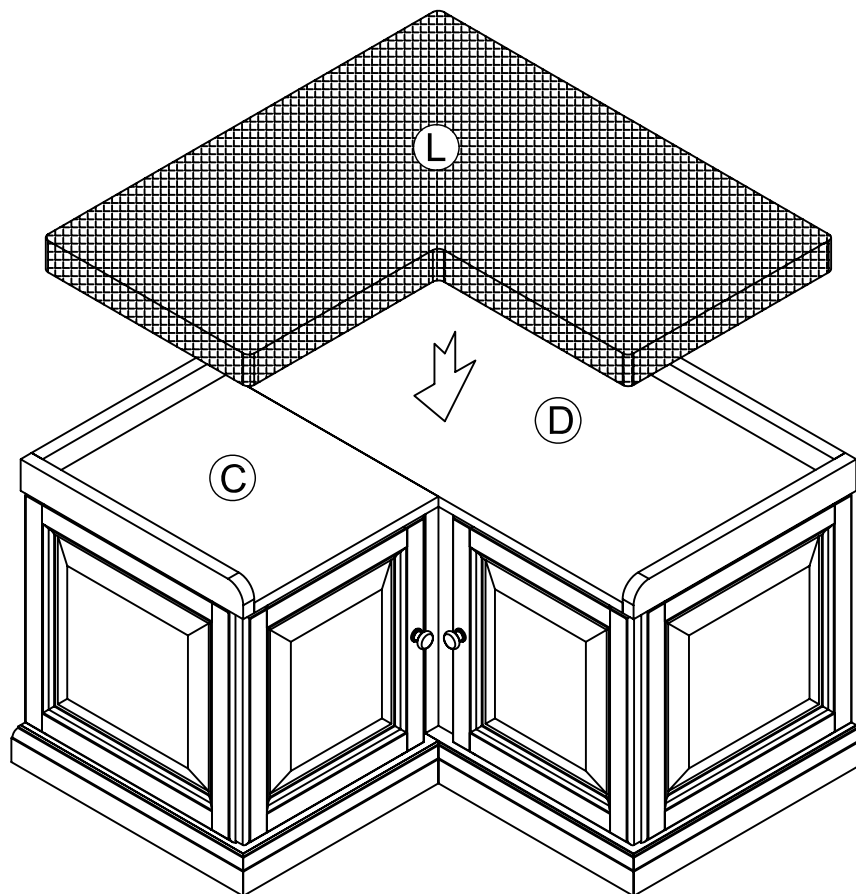

- PLACE THE CUSHION (L) ONTO THE TOP PANEL (C & D).