



Owner's Manual

EFCB Serial

Control Box

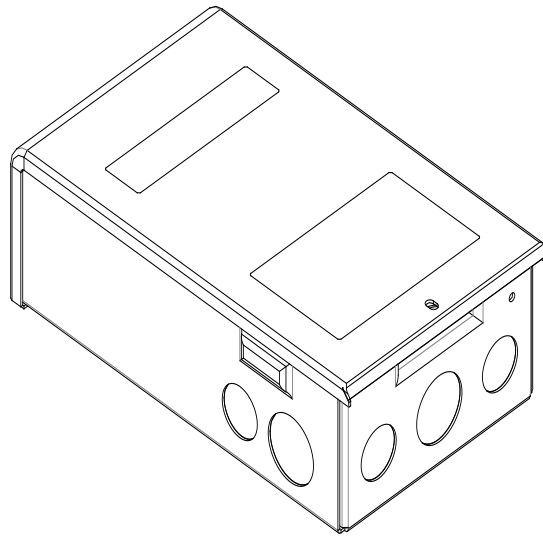

TABLE OF CONTENTS

General Safety	2
Specifications	3
Wiring Connection	3
Warranty	4



Before you start

Control box is an electrical device designed to operate in inherently wet environments.

ALWAYS USE EXTREME CAUTION

when installing or maintaining this product!

Need Help: Call 1-877-326-3561 for assistance;
Do Not Return to Store

GENERAL SAFETY

Important Safety Instructions

Carefully read and follow all safety instructions in this manual and on pump.

SAVE THESE INSTRUCTIONS – This manual contains important instructions that should be followed during installation, operation, and maintenance of the product.

Save this manual for future reference.

Safety Labels



This is the safety alert symbol. When you see this symbol on your pump or in this manual, look for one of the following signal words and be alert to the potential for personal injury!



DANGER Indicates a hazard which, if not avoided, will result in death or serious injury.



WARNING Indicates a hazard which, if not avoided, could result in death or serious injury.



CAUTION Indicates a hazard which, if not avoided, could result in minor or moderate injury.

NOTICE indicates practices not related to personal injury.

Keep safety labels in good condition. Replace missing or damaged safety labels.

General Safety

Do not allow control box or any system component to freeze. To do so will void warranty.

Periodically inspect control box and system components.

Wear safety glasses at all times when working on pumps.



WARNING Electric shock hazard. Disconnect power before opening.

Applications

These Control Boxes remotely controls 3 wire single phase Submersible Deep Well Pump Motors and are to be used specifically with motors manufactured by Faradyne. See the Electrical Ratings section for list of motors to be used with respective control boxes.

Specification

Model	HP	Voltage	Hz	Amps	Ph	Capacitor	Relay
EFCB5-1	1/2	115V	60	8.8	1	250-300Mfd, 115V	115V
EFCB5	1/2	230V	60	5.3	1	59-71Mfd, 220V	230V
EFCB7	3/4	230V	60	6.6	1	86-103Mfd, 220V	230V
EFCB10	1	230V	60	8.1	1	105-126Mfd, 220V	230V

Wiring connection

1. All electrical wiring must be in accordance with local code and only qualified electricians should make the installations.
2. All wires should be checked for shorts to ground with an ohmmeter or megger after the connections are made. This is IMPORTANT, as one grounded wire can cause failure of the pump, control panel or personal injury.

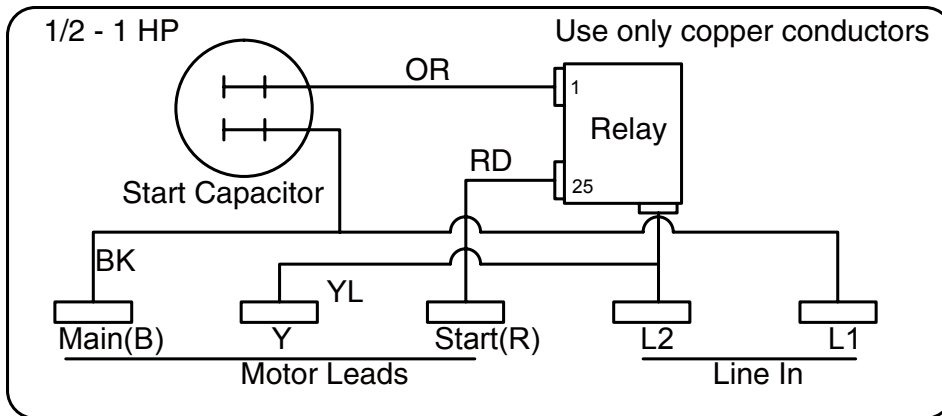

Wiring Diagram (Continued)

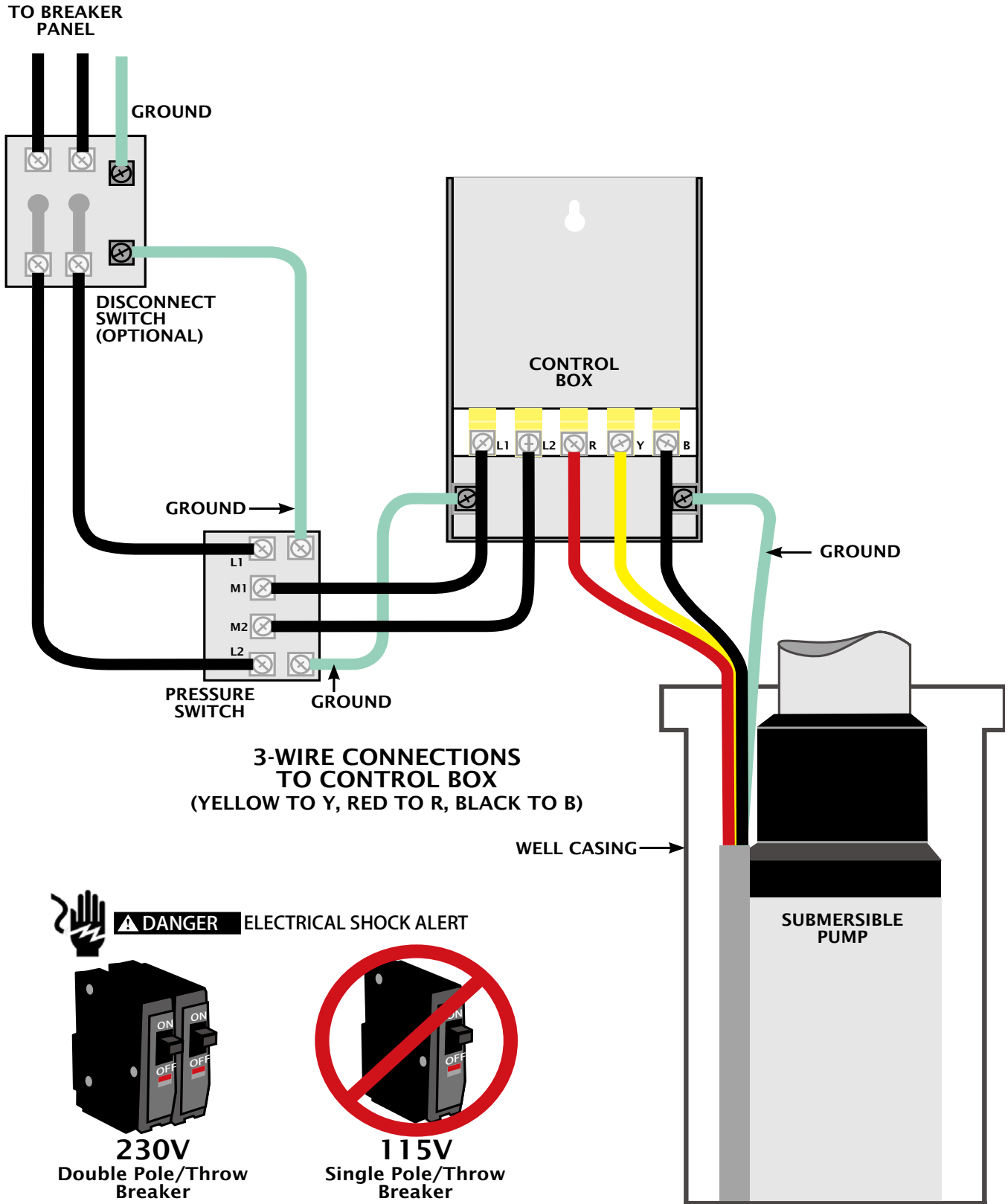

Typical connection--- connect with 4" deep well pump

SERVICE PARTS

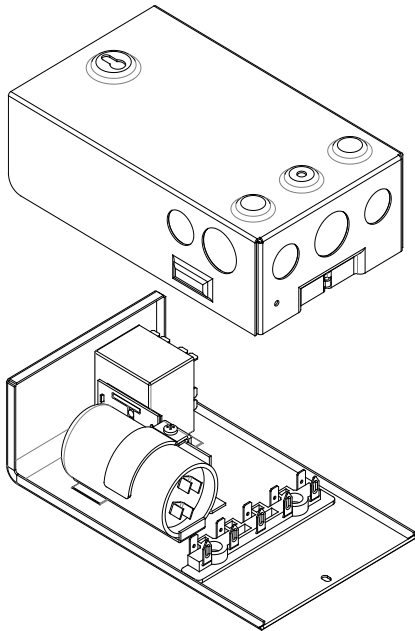

Number	Description	Part Number				Quantity
		EFCB5-1	EFCB5	EFCB7	EFCB10	
1	Start Capacitor	091CBSC01	091CBSC02	091CBSC03	091CBSC04	1
2	Relay	091CBSR01	091CBSR02	091CBSR02	091CBSR02	1

WARRANTY

Retain Original Purchase Receipt for Warranty Eligibility

Limited Warranty

Manufacturer warrants to the original consumer purchaser ("Purchaser" or "You") that its products are free from defects in material and workmanship for a period of twelve (12) months from the date of the original consumer purchase. If, within twelve (12) months from the original consumer purchase, any such product shall prove to be defective, it shall be repaired or replaced at manufacturer's option, subject to the terms and conditions set forth herein. Note that this limited warranty applies to manufacturing defects only and not to ordinary wear and tear. All mechanical devices need periodic parts and service to perform well. This limited warranty does not cover repair when normal use has exhausted the life of a part or the equipment.

The original purchase receipt and product warranty information label are required to determine warranty eligibility. Eligibility is based on purchase date or original product – not the date of replacement under warranty. The warranty is limited to repair or replacement of original purchased product only, not replacement product (i.e. one warranty replacement allowed per purchase).

Purchaser pays all removal, installation, labor, shipping, and incidental charges. Claims made under this warranty shall be made by returning the product to the retail outlet where it was purchased or to the factory immediately after the discovery or any alleged defect. Manufacturer will subsequently take corrective action as promptly as reasonably possible. No requests for service will be accepted if received more than 30 days after the warranty expires. Warranty is not transferable and does not apply to products used in commercial/rental applications.

General Terms and Conditions; Limitations of Remedies

You must pay all labor and shipping charges necessary to replace product covered by this warranty. This warranty does not apply to the following: (1) acts of God; (2) products which, in manufacturer's sole judgment, have been subject to negligence, abuse, accident, misapplication, tampering, or alteration; (3) failures due to improper installation, operation, maintenance or storage; (4) atypical or unapproved application, use or service; (5) failures caused by corrosion, rust or other foreign materials in the system, or operation at pressures in excess of recommended maximums.

This warranty sets forth manufacturer's sole obligation and purchaser's exclusive remedy for defective products. MANUFACTURER SHALL NOT BE LIABLE FOR ANY CONSEQUENTIAL, INCIDENTAL, OR CONTINGENT DAMAGES WHATSOEVER. THE FOREGOING LIMITED WARRANTIES ARE EXCLUSIVE AND IN LIEU OF ALL OTHER EXPRESS AND IMPLIED WARRANTIES, INCLUDING BUT NOT LIMITED TO IMPLIED WARRANTIES OF MERCHANTABILITY AND FITNESS FOR A PARTICULAR PURPOSE. THE FOREGOING LIMITED WARRANTIES SHALL NOT EXTEND BEYOND THE DURATION PROVIDED HEREIN.

Some states do not allow the exclusion or limitation of incidental or consequential damages or limitations on how long an implied warranty lasts, so the above limitations or exclusions may not apply to you. This warranty gives You specific legal rights and You may also have other rights which vary from state to state.



1899 Cottage Street, Ashland, Ohio 44805
Telephone: 1-877-326-3561
Fax: 1-877-326-1994
www.ecofoproducts.com