

Programming the Water Softener.

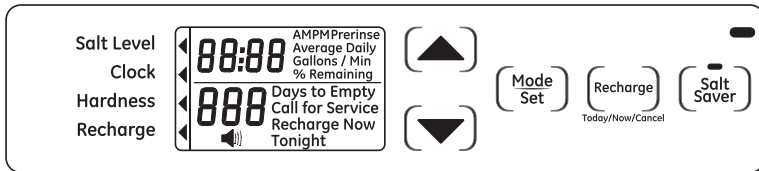

When the transformer is plugged into the electrical outlet, a model code and test number (example: J3.4 & H31) are shown in the display. Then, "12:00 PM" begins to flash. An arrow ◀ is displayed next to **CLOCK** on the face plate decal.

CONTROL OPERATION:

- **CONTROL SETTINGS REQUIRED** upon initial installation and after an extended power outage.
- Use the **MODE/SET** button to scroll arrow to desired control function set.
- After the mode is selected use the UP ▲ and DOWN ▼ buttons to change the settings of the control.
- Press the **MODE/SET** button to accept changes.
- A "beep" sounds while pressing buttons for control programming. One beep signals a change in the control display. Repeated beeps mean the control will not accept a change from the button you have pressed, and you should select another button.

SET TIME OF DAY

1. Press **MODE/SET** button until the arrow ◀ points to **CLOCK**.
2. Press the UP ▲ or DOWN ▼ buttons to set the present time. UP ▲ moves the display ahead; DOWN ▼ sets the time back. Be sure AM and PM is correct.

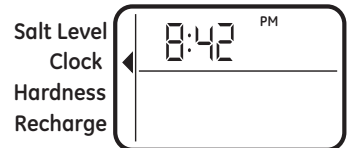

NOTE: Press buttons and quickly release to slowly advance the display one number at a time. Hold the buttons down for fast advance.

3. When the correct time is shown in the display, press **MODE/SET** to accept.

Programming the Water Softener.

SET WATER HARDNESS NUMBER

1. Press the **MODE/SET** button until the arrow ◀ points to **HARDNESS**. A flashing 25 will appear in the display.

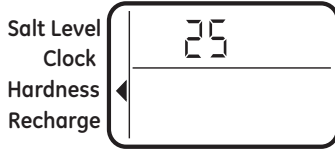

2. Press the UP ▲ or DOWN ▼ buttons to set your water hardness number.

NOTE: If your water supply contains iron, compensate for it by adding to the water hardness number. For example, assume your water is 20 gpg hard and contains 2 ppm iron. Add 5 to the hardness number for each 1 ppm or iron. In this example, you would use 30 for your hardness number.

$$\begin{array}{r} 20 \text{ gpg hardness} \\ 2 \text{ ppm iron} \times 5 = 10 \text{ } +10 \\ \hline \text{(times)} \quad \quad \quad 30 \text{ HARDNESS NUMBER} \end{array}$$

3. When the display shows your water hardness (in grains per gallon), press **MODE/SET** to accept.

You can get the grains per gallon (gpg) hardness of your water supply from a water analysis laboratory. If you are on a municipal supply, call your local water department. Or call Legend Technical Services, an independent laboratory, to request a water hardness test kit at 1.800.949.8220, Option 4. If your report shows hardness in parts per million (ppm) or milligrams per liter (mg/l), simply divide by 17.1 to get the equivalent number of grains per gallon.

SET RECHARGE (STARTING) TIME

1. Press the **MODE/SET** button until the arrow ◀ points to **RECHARGE**.



NOTE: A flashing 2:00 AM (factory default) should show in the display. This is a good time for recharge to start (takes about 2 hours) in most households because water is not in use. HARD WATER is bypassed to house faucets during recharge.

If no change is needed, go to step 3. To Change the recharge starting time, follow step 2.

2. Press UP ▲ or DOWN ▼ button to set the desired recharge start time. Be sure to observe the AM or PM as you did when setting the time of day.
3. Press the **MODE/SET** button to accept.

Programming the Water Softener.

SET SALT LEVEL

1. Press the **MODE/SET** button until the arrow ◀ points to **SALT LEVEL**.

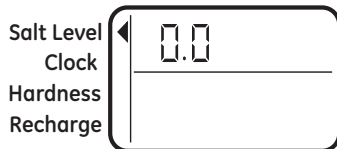

2. Determine level of salt in brine tank using the numbered scale on side of brine well, inside brine tank (see Figure 15).

3. Press UP ▲ or DOWN ▼ button to set the **SALT LEVEL** to correspond to level on the numbered scale in brine tank.

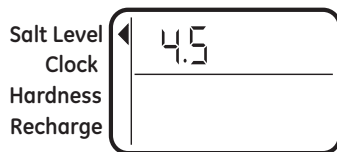

NOTE: Each press of a button changes the level by increments of 0.5 up to 8.0. Lowering the salt level below zero turns the **SALT LEVEL** indicator OFF.

4. Press the **MODE/SET** button to accept. The display shows the present time of day and **DAYS TO EMPTY**.

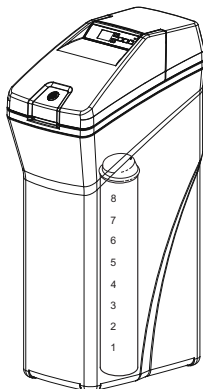
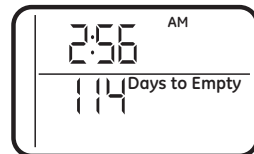

Figure 15

DAYS TO EMPTY

The words **DAYS TO EMPTY** and a number are shown in the lower half of the display. This information is shown in the normal run display. This is to inform the user of the number of days before the salt level in the brine tank reaches Level 0. There will be salt left in the salt tank, but it may not be sufficient to fully recharge the system. Salt should be added at this time to avoid hard water. The value is updated daily and whenever the **SALT LEVEL** value is changed.



NOTE: For the first several weeks of operation, the **DAYS TO EMPTY** may provide erratic operation. For example, the blue indicator light may flash, showing that more salt is required when the actual salt level in the tank is well above the Level 0. In some cases, the **DAYS TO EMPTY** may even increase over a several week period.

It takes a couple of months for the water softener to learn **your** water usage pattern. Once it does this, it will accurately determine actual salt usage pattern. During this first period, check salt level when blue indicator light flashes. If the salt level in the tank is at Level 1 or above, allow system to run. Be sure to reset your salt level indicator each time you add salt to the system.

START A RECHARGE

Press the **RECHARGE** button and hold for three seconds, until "RECHARGE NOW" begins to flash in the display, starting a recharge. This recharge draws the sanitizing bleach or brine into and through the water softener. Any air remaining in the water softener is purged to the drain. During this time periodically check for leaks.

NOTE: As with all other water system applications, leaks may occur. Leaks may not be immediately apparent. Recheck 24 hours after first recharge cycle is complete.

Programming the Water Softener.

OPTIONAL CONTROL SETTINGS

The controller display has several options and features.

LOW SALT ALARM

The **LOW SALT ALARM**, when enabled, will sound the beeper when the **DAYS TO EMPTY** value is 15 days or less. To change this setting, press and hold the **MODE/SET** button for 3 seconds or hear a beep. **ON** (factory default) or **OFF** will flash in the display. Press the **UP ▲** or **DOWN ▼** buttons to toggle this feature **ON** or **OFF**. Press the **MODE/SET** button to accept, and the display will move to the **PRERINSE ON/OFF** screen. Press the **UP ▲** or **DOWN ▼** buttons to turn prerinse on or off.

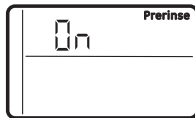

PRERINSE

If your water contains sediment the prerinse feature will remove sediment from the resin bed prior to regeneration.

Press the **MODE/SET** button and the display will move to **Prerinse Time** mode. In this screen you can adjust the duration of the prerinse by pressing the **UP ▲** or **DOWN ▼** buttons. Press the **MODE/SET** button to accept, and the display will move to the **Back Wash** screen.

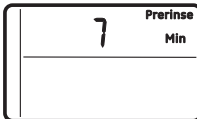

BACKWASH AND FAST RINSE

If you experience salty tasting water after regeneration, you may need to increase the backwash and fast rinse times. The cycle times during regenerations are determined by the softener's electronic controller. However, you may increase the backwash and fast rinse times. You may add up to 10 minutes.

For Backwash, you can add up to 10 minutes in 1 minute increments, by pressing the **UP ▲** button, or subtract time by pressing the **DOWN ▼** button.

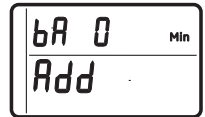

For Fast Rinse, press **MODE/SET** and the display moves to the add fast rinse time screen. You can add up to 10 minutes in 1 minute increments, by pressing the **UP ▲** button, or subtract time by pressing the **DOWN ▼** button. Press the **MODE/SET** button to accept, and the display will move to the **Run Display** screen.

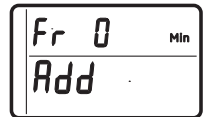

SALT SAVER

When this feature is **ON**, the water softener will operate at salt efficiencies of 4000 grains of hardness per pound of salt or higher (May recharge more often using smaller salt dosage and less water). The softener is shipped with this feature set **OFF**.

In the state of California: You must turn the Salt Saver Feature ON. This may initiate more frequent recharges. However, it will operate at 4,000 grains per pound of salt.

To turn Salt Saver ON: Press the Salt Saver button once until the blue status light above the button is **ON**.



Programming the Water Softener.

FEATURE: OTHER DATA DISPLAY

These models have an option to have the run display indicate different information. The information displayed on the top half of the display can be changed to one of the following by pressing UP ▲ or DOWN ▼ buttons:

• CAPACITY REMAINING

– This is the percentage of water softening capacity remaining. Immediately after a regeneration, 100% shows. As water is used, the percentage will decrease until the next regeneration. During regenerations, the percentage increments upward.

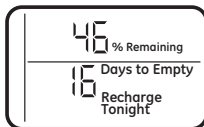

When present time is displayed, press the DOWN ▼ button; **% Remaining** will appear in the display. The value shown is between 0 and 100 percent. This value is based on current operating capacity. Pressing the UP ▲ button will return the screen to the previous display.

• AVERAGE DAILY GALLONS

– The figure displayed is the average gallons of water used by the household each day over the past seven-day period.

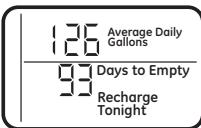

Press the DOWN ▼ button again to display the Average Daily Gallons. **Average Daily Gallons** will appear in the display. This value is updated every night at midnight. Pressing the UP ▲ button will return the screen to the previous display.

• FLOW RATE, GPM

– When using soft water, this display shows the flow rate passing through the softener (in gallons per minute). Zero shows if water is not passing through the softener.

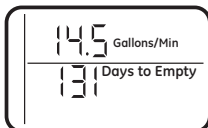

Press the DOWN ▼ button again to display the flow rate. **Gallons/Min** will appear in the display. This value is updated every ½ second. Pressing the UP ▲ button will return the screen to the previous display. Pressing the DOWN ▼ button will return the screen to the present time display.

RESETTING TO FACTORY DEFAULT

To reset the electronic controller to its factory default for all settings (time, hardness, etc.):

1. Press the **MODE/SET** button and hold until the display changes twice to show the flashing mode code.
2. Press the UP ▲ button to display a flashing "SoS".



3. Press the **MODE/SET** button and the electronic controller will restart.
4. Set the present time, hardness, etc, as described in the Programming the Water Softener section

Programming the Water Softener.

POWER OUTAGE MEMORY

If electrical power to the water softener is lost, “memory” built into the timer circuitry will keep all settings for up to 24 hours. While the power is out, the display is blank and the water softener will not regenerate. When electrical power is restored, the following will occur:

Reset the present time only if the display is flashing. The **HARDNESS** and **RECHARGE TIME** never require resetting unless a change is desired. Even if the clock is incorrect after a long power outage, the softener operates as it should to keep your water soft. However, regenerations may occur at the wrong time of day until you reset the clock to the correct time of day.

NOTE: If the water softener was regenerating when power was lost, it will now finish the cycle.

BLUE INDICATOR LIGHT

Steady blue light indicates that the unit is working correctly. The light flashes when the unit needs attention from the user.

- Light will also flash when power to the unit has been interrupted. Check the **PRESENT TIME** setting.
- Light flashes and **DAYS TO EMPTY** flashes - check salt level and add salt as required.
- Light flashes and **Err** is in the display - electrical problem with system.

LOW SALT SIGNAL

When the **DAYS TO EMPTY** drops to 15, the blue indicator light and **DAYS TO EMPTY** in the display will flash every second and the alarm will beep every 30 seconds (from 8:00 AM to 8:00 PM), to notify the user that the unit is running low on salt. As soon as any button is pressed, the alarm will stop beeping. The blue indicator light and **DAYS TO EMPTY** will continue to flash. Once salt is added to the brine tank and the **SALT LEVEL** is reset, the **DAYS TO EMPTY** will be reset.

ERROR SIGNALS

If there is an error code detected, the blue indicator light will flash 4 times every second, the display will flash **Err** and the alarm will beep every 30 seconds (from 8:00 AM to 8:00 PM) to signal that the softener requires service. The alarm can be turned off by pressing any button, but the blue indicator light and display will continue to flash.

Disconnect the transformer from the wall outlet momentarily, and plug it back in. The normal display will appear. The motor may run for several minutes, as the unit resets. If the problem is not corrected, the error code will reappear in 8 minutes. See the *Before you Call for Service* section to assist in troubleshooting the water softener.



Care and cleaning.

ADJUSTING YOUR WATER HARDNESS

The blend adjusting knob (Figure 16) gives the ability to finely adjust hardness of the treated water leaving the water softener. If slightly harder water is desired than is normally delivered by the water softener, the blend adjusting knob can divert a small stream of hard water and blend it with the soft water entering the home. The amount of water diverted is controlled by turning a blend adjusting knob on the end cap of the valve stem.

NOTE: To get full performance from your water softener leave blending valve in the factory closed position.

To make adjustments to water hardness:

1. Hold bypass handle to keep the valve stem from rotating (see Figure 16). Loosen hex nut on blend adjusting knob by turning the hex nut counterclockwise, (see Figure 17).
2. **TO INCREASE HARDNESS:** With the bypass in the service position (see Figure 16) hold the handle to keep the valve stem from rotating and turn the blend adjusting knob counterclockwise up to 2 turns from the closed position. It is recommended that adjustments be made in quarter turn increments over several weeks until the desired hardness is achieved. **NOTE:** Once an adjustment is made to the blend valve knob the change in water hardness at the homes faucets or shower heads may take several days to be noticed. This delay is due to the large amounts of already conditioned water in the pipes and water heater that must be exchanged before a change in hardness can be noticed. Have the water tested to determine the actual water hardness.
3. **TO DECREASE HARDNESS:** With the bypass in the service position (see Figure 16) hold the handle to keep the valve stem from rotating and turn the blend adjusting knob clockwise. When the knob will not turn anymore, hard water is no longer being blended into the soft water.
4. Once the desired hardness is achieved tighten the hex nut (see Figure 17) clockwise until it comes in contact with the bypass stem.

NOTE: To meet the water softener performance specifications and reduction of barium and radium claims the adjustable hardness must be kept in the "OFF" position. The off position is achieved when the blend adjusting knob is fully rotated clockwise until it stops.

SERVICE POSITION (Normal Softener Operation)

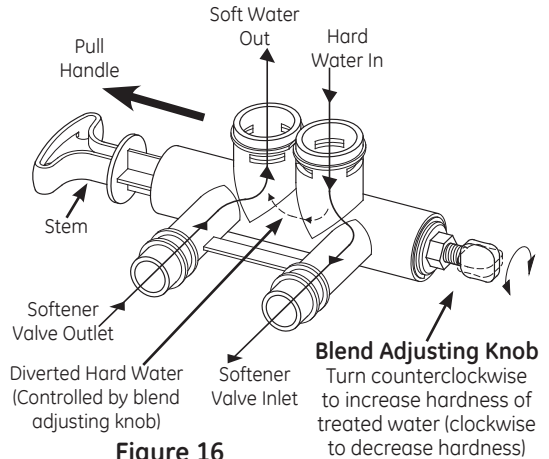

Figure 16

BYPASS POSITION

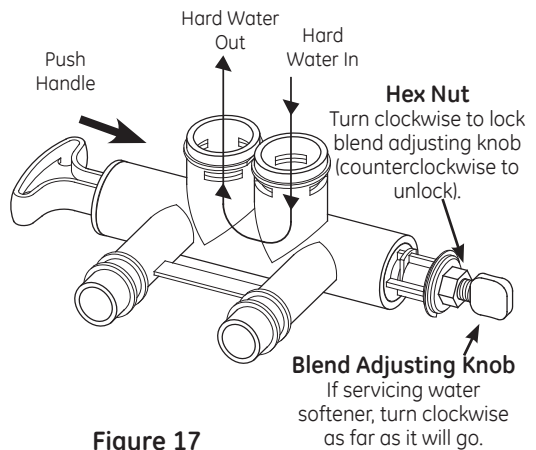

Figure 17

CAUTION! If the water softener is to be serviced or disconnected from the bypass valve, the blend adjusting knob must be turned all the way clockwise to close the diversion path and prevent water leaking from the softener valve inlet of the bypass.

Care and cleaning.

CHECKING THE SALT STORAGE LEVEL and REFILL

Brine (salt dissolved in water) is needed for each and every recharge. The water for making brine is metered into the salt storage area by the water softening system valve and control. **However, you must keep the tank supplied with salt.**

ADDING SALT

Lift the salt hole cover and check the salt storage level frequently. If the water softener uses all the salt before you refill it, you will experience hard water. Until you have established a refilling routine, check the salt every two or three weeks. Always add if less than 1/4 full. Be sure the brinewell cover is on.

NOTE: if using potassium chloride (KCl), do not fill above level 4 on the brinewell decal.

NOTE: In humid areas, it is best to keep the salt storage level lower, and to refill more often to avoid salt "bridging".

Recommended Salt: Nugget, pellet or coarse solar salts with less than 1% impurities.

Salt Not Recommended: Rock salt, high in impurities, block, granulated table, ice melting, ice cream making salts, etc.

⚠ CAUTION:
Water softening salt with iron removing additives:

Some salts may have an additive to help the water softening system handle iron in the water supply. Although this additive may help to keep the water softening system resin clean, it may also release corrosive fumes that weaken and shorten the life of some water softening system parts.

CLEANING IRON OUT OF THE WATER SOFTENING SYSTEM

Your water softening system takes hardness minerals (calcium and magnesium) out of the water. Also, it can control some (see the Specification Guidelines section) "clear water" iron. With clear water iron, water from a faucet is clear when first put into a glass. After 15 to 30 minutes, the water begins to cloud or turn rust colored. A water softening system **will not** remove any iron that makes the water cloudy or rusty as it comes from the faucet (called red water iron). To take red water iron out of water, or over the maximum of clear water iron, an iron filter or other equipment is needed.

GE recommends using **Super Iron Out**[®] to clean your resin bed if your iron content is high. Use **Super Iron Out**[®] with every 40lb. bag of salt as preventative maintenance against rust build up. Clean the bed at least every six months, or more often if iron appears in the soft water between cleanings.

IMPORTANT: It is important to mix the resin bed cleaner with water (following the manufacturer's instructions), pour it into the **brinewell** (see Figure 9) and recharge the softener immediately. Do not pour the resin bed cleaner in with the salt, as it will not be as effective in cleaning the resin, and can cause damage to the softener if it is left in the brine tank for an extended period due to the corrosive gases that are formed.

Routine Maintenance.

CLEANING THE NOZZLE AND VENTURI ASSEMBLY

A clean nozzle and venturi is needed for the water softening system to work properly. This small unit makes the suction to move brine from the salt storage area to the resin tank during recharge. If it becomes plugged with sand, dirt, etc., the water softening system will not work and you will get hard water.

To get to the nozzle and venturi, remove the water softening system top cover. Be sure the water softening system is in service cycle (no water pressure at nozzle and venturi). Then, while holding the nozzle and venturi housing with one hand, remove the cap. Lift out the screen support and screen, then the nozzle and venturi. Wash and rinse the parts in warm water until clean. If needed, use a small brush to remove iron or dirt. Also check and clean the gasket.

NOTE: Some models have a small flow plug located in the nozzle and venturi, and/or a small cone shaped screen in the housing. Be sure to check and clean these parts, if your model is so equipped.

Carefully replace all parts in the correct order. Lightly lubricate the o-ring seal with clean silicone grease or petroleum jelly and place in position. **Install and tighten the cap, by hand only. Do not overtighten the cap.**

BREAKING A SALT BRIDGE

Sometimes, a hard crust or salt bridge forms in the salt storage area. It is usually caused by high humidity or the wrong kind of salt. When the salt bridges, an empty space forms between the water and salt. Then salt will not dissolve in the water to make brine.

If the brine tank is full of salt, it is hard to tell if you have a salt bridge. Salt is loose on top, but the bridge is under it. The following is the best way to check for a salt bridge.

Salt should be loose all the way to the bottom of the tank. Take a broom handle or like tool, and carefully push it down into the salt, working it up and down. If the tool strikes a hard object (be sure it's not the bottom or sides of the tank), it's most likely a salt bridge. Carefully break the bridge with the tool. **Do not** pound on the walls of the tank. To help dissolve the salt bridge pour one gallon of warm water (not hot) into the tank.

If the wrong kind of salt made the bridge, take it out. Then fill the tank with nugget or pellet salt only. In humid areas, it is best to fill with less salt, more often to prevent a salt bridge from forming.

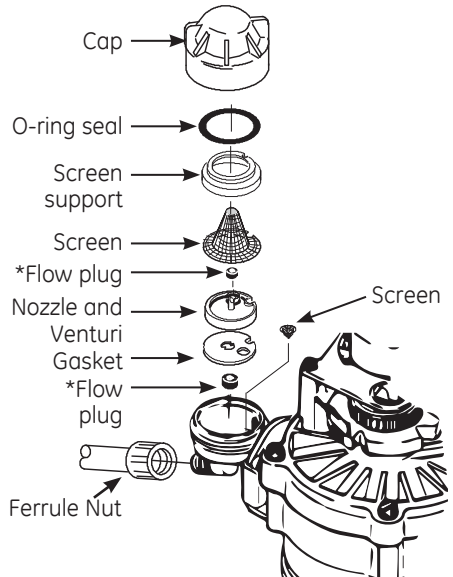

IMPORTANT: Be sure small holes in the gasket are centered directly over the small holes in the nozzle and venturi housing.

*Install with numbered side up, concave side down.

