



Count on it.

Parts Catalog

String Mower

Model No. 58620—Serial No. 321000001 and Up



Ordering Replacement Parts

To order replacement parts, please supply the part number, the quantity, and the description of each part desired.

Understanding Reference Numbers

Each identified part in an illustration has a reference number. The reference number for a part also appears in the parts list, along with other information about the part.

This catalog uses two special reference number formats, one to indicate parts in a service assembly and another to indicate the quantity of a given part in an illustration.

Service Assembly Reference Numbers

Parts in service assemblies have reference numbers in the form a:b. The a represents the reference number of the entire service assembly and the b represents a sequential number unique to each part within the service assembly.

For example, a wheel assembly might be identified by reference number 6, the tire by 6:1, the valve by 6:2, and the wheel by 6:3. When you order the assembly identified by reference number 6, you receive all parts identified by reference numbers 6:1, 6:2, and 6:3. However, you may also order any part individually. Reference numbers of this type appear in illustration and in parts lists.

Reference Numbers Indicating Quantity

In an illustration, if a reference number indicates more than one part, the reference number has the form nX y. The n represents the quantity of the part, the X is the multiplication symbol, and the y represents the reference number.

For example, in an illustration, the reference number 2X 37 means that two of the parts identified by reference number 37 are indicated.

Contents

Frame Assembly 4
Mower Head Assembly 6
Handle Assembly 8
Engine Assembly 10

Frame Assembly

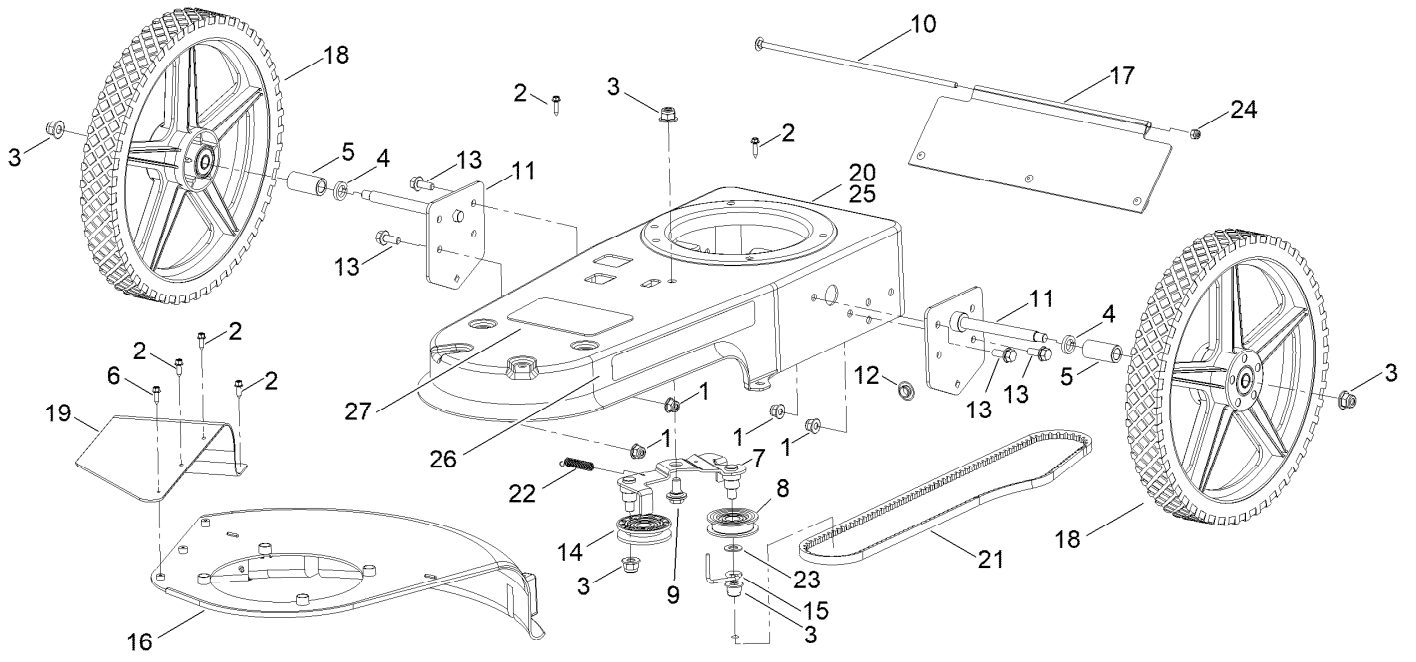

Frame Assembly (continued)

<i>Ref.</i>	<i>Part Number</i>	<i>Qty.</i>	<i>Description</i>	<i>Ref.</i>	<i>Part Number</i>	<i>Qty.</i>	<i>Description</i>
1	144-4789	4	Nut-Hex	15	144-4828	1	Guide-Belt
2	144-4816	2	Screw-PPH	16	144-4834	1	Shield-Trimmer
3	144-4817	5	Nut-Hex	17	144-4830	1	Shield-Trailing
4	144-4818	2	Washer-Lock	18	144-4831	2	Wheel ASM
5	144-4819	2	Spacer-Tube	19	144-4845	1	Chute-Discharge
6	144-4810	4	Screw-Phwh	20	144-4829	1	Frame-Deck
7	144-4820	1	Arm-Idler	21	144-4832	1	Belt-V
8	144-4821	1	Pulley-Idler, Flat	22	144-4833	1	Spring-Extension
9	144-4822	1	Screw-HHF	23	144-4835	1	Washer-Plain
10	144-4823	1	Bolt-Carriage	24	144-4836	1	Nut-Hex
11	144-4824	2	Axle ASM	25	144-4840	1	Decal-Warning
12	144-4825	1	Grommet	26	144-4838	1	Decal
13	144-4784	4	Screw-HHF	27	144-4837	1	Decal-Deck
14	144-4827	1	Pulley-Idler				

Mower Head Assembly

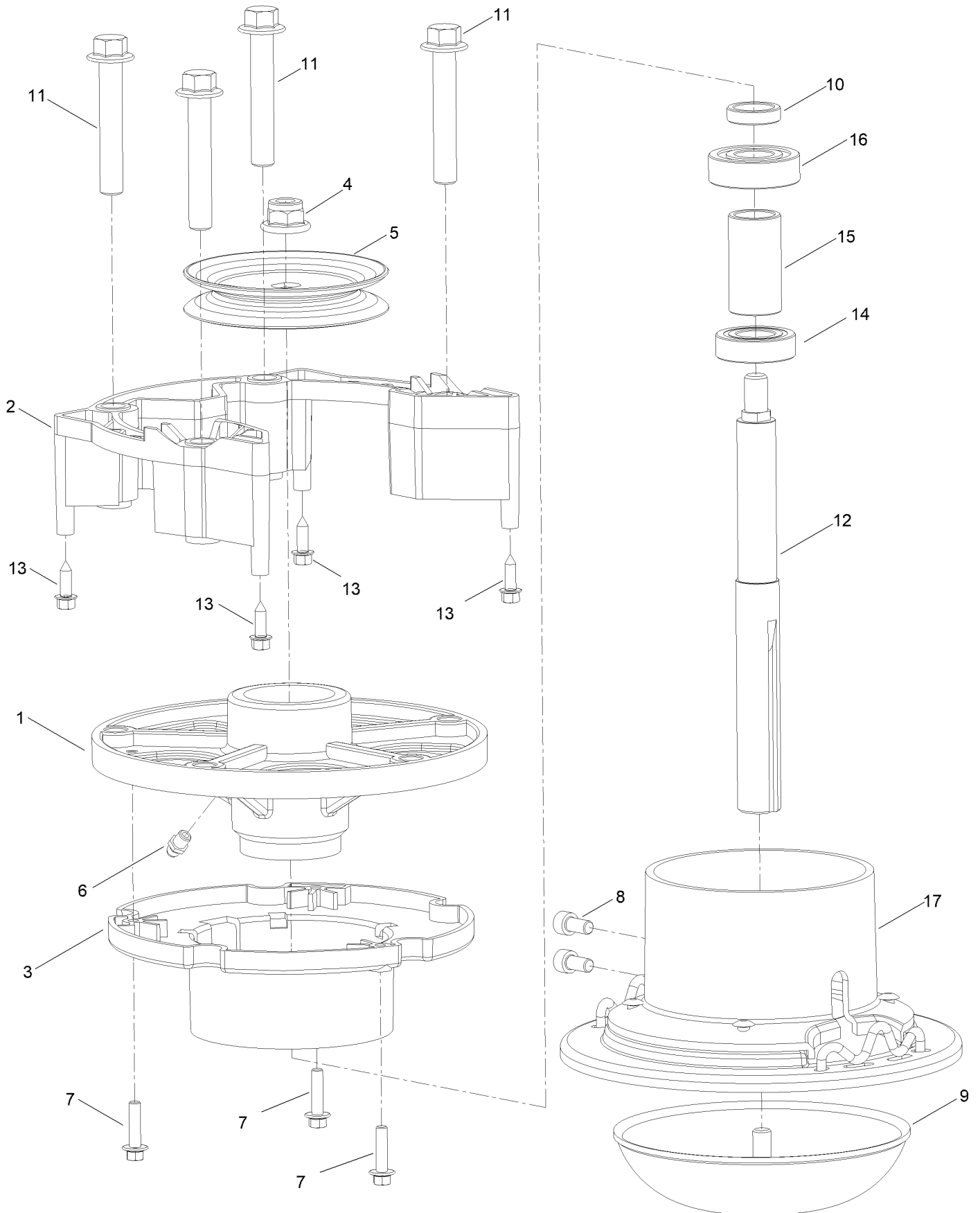

Mower Head Assembly (continued)

<i>Ref.</i>	<i>Part Number</i>	<i>Qty.</i>	<i>Description</i>	<i>Ref.</i>	<i>Part Number</i>	<i>Qty.</i>	<i>Description</i>
1	144-4797	1	Housing-Jackshaft, Upper	10	144-4807	1	Spacer
2	144-4798	1	Spacer-Head, Cutting	11	144-4808	4	Screw-HHF
3	144-4799	1	Housing-Trimmer, Lower	12	144-4809	1	Shaft-Trimmer
4	144-4800	1	Nut-Hex	13	144-4810	4	Screw-Phwh
5	144-4801	2	Pulley-Drive	14	144-4812	1	Bearing-Ball
6	144-4802	1	Fitting-Grease	15	144-4811	1	Spacer-Trimmer
7	144-4803	3	Screw-HHF	16	144-4813	1	Bearing-Ball
8	144-4804	2	Screw-Shcs	17	144-4806	1	String Wrap ASM
9	144-4805	1	Height Guide ASM				

Handle Assembly

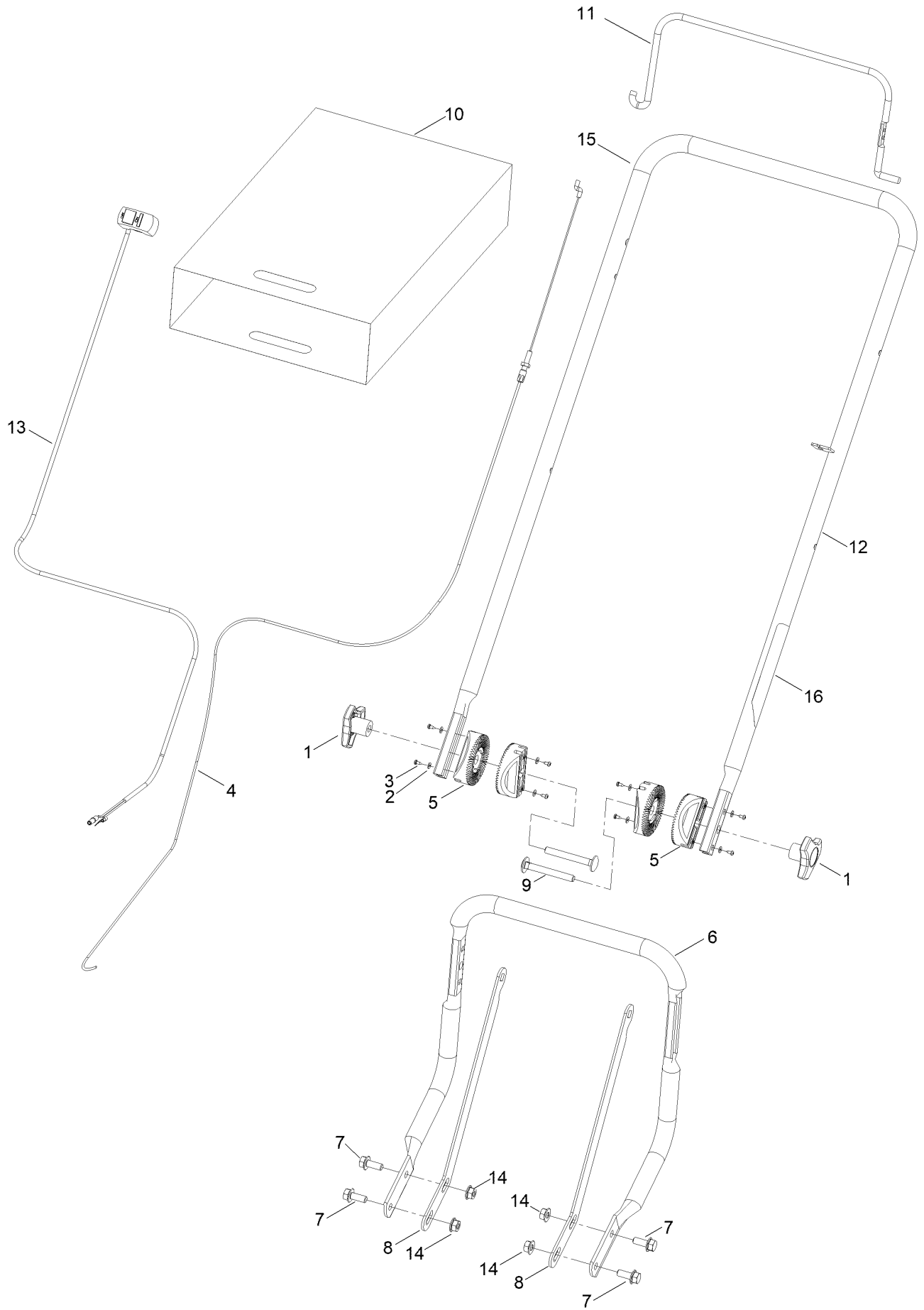

Handle Assembly (continued)

<i>Ref.</i>	<i>Part Number</i>	<i>Qty.</i>	<i>Description</i>	<i>Ref.</i>	<i>Part Number</i>	<i>Qty.</i>	<i>Description</i>
1	144-4733	2	Knob-Handle	9	144-4786	2	Bolt-Carriage
2	144-4778	8	Washer-Plain	10	144-4846	1	Manual ASM
3	144-4779	8	Screw-PPH	11	144-4787	1	Bail-Clutch
4	144-4781	1	Cable-Clutch	12	144-4780	1	Handle-Upper
5	144-4782	4	Pivot-Handle	13	144-4844	1	Switch-Stop
6	144-4783	1	Handle-Lower	14	144-4788	4	Nut-Hex
7	144-4784	4	Screw-HHF	15	133-8062	1	Decal-Arrestor, Spark
8	144-4785	2	Bracket-Support, Handle	16	144-4839	1	Decal-Handle

Engine Assembly

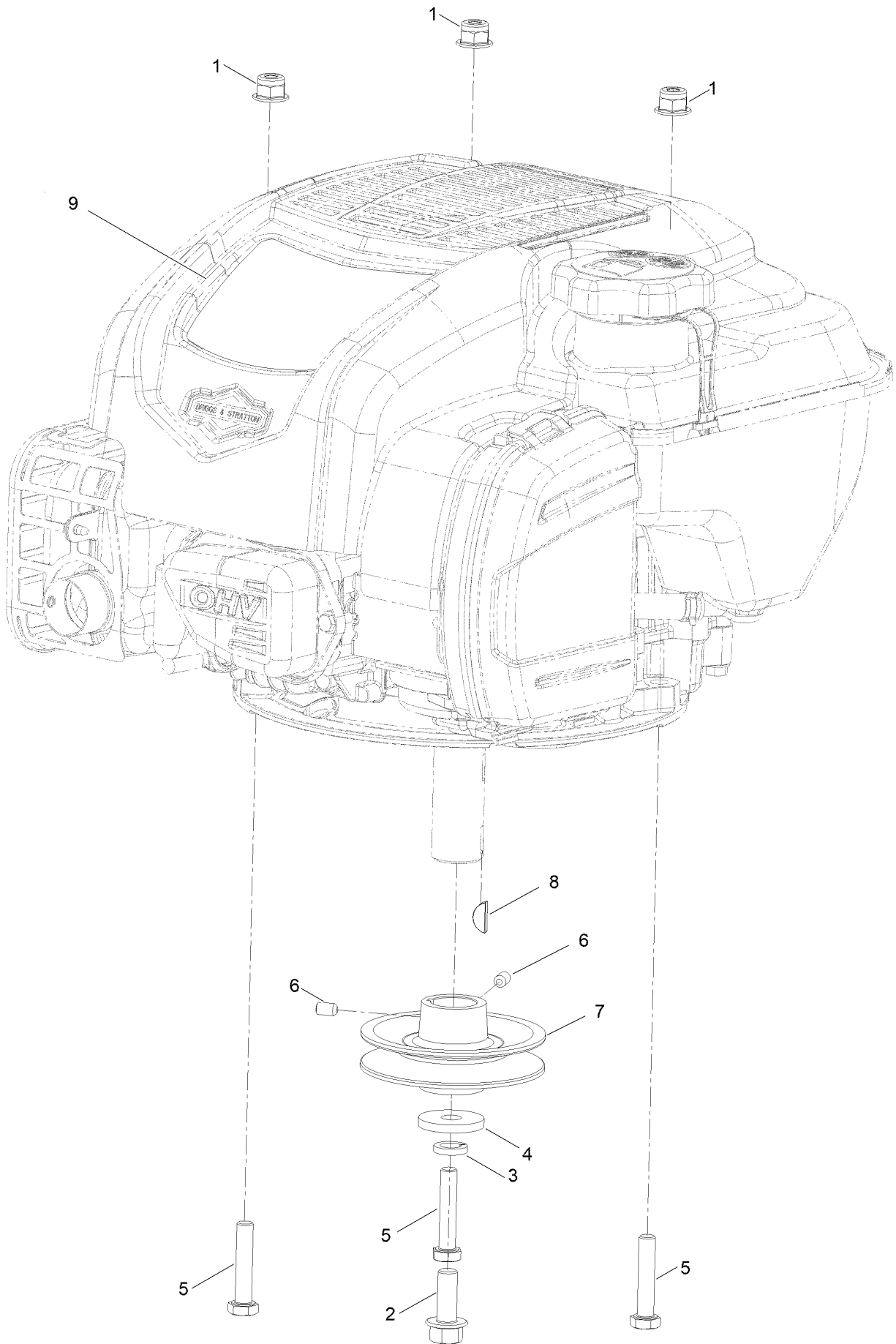

Engine Assembly (continued)

<i>Ref.</i>	<i>Part Number</i>	<i>Qty.</i>	<i>Description</i>	<i>Ref.</i>	<i>Part Number</i>	<i>Qty.</i>	<i>Description</i>
1	144-4789	3	Nut-Hex	6	144-4794	2	Screw-Set
2	144-4790	1	Screw-HHF	7	144-4795	1	Pulley-Traction, Engine
3	144-4791	1	Washer-Lock	8	144-4796	1	Woodruff Key
4	144-4792	1	Washer-Plain	9	144-4841	1	Decal-Engine
5	144-4793	3	Screw-HH				



Count on it.