

#### STEP 4

Attach Top Panel (D) on top of the unit using Screw (1), Dowel (2) and Cam-lock Screw/Nut (5) as shown.

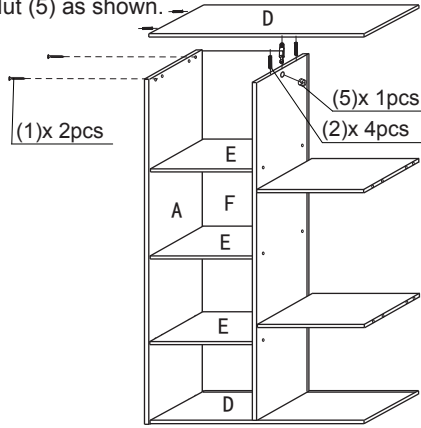

#### STEP 5

Insert another Back Panel (F) to assembled unit.

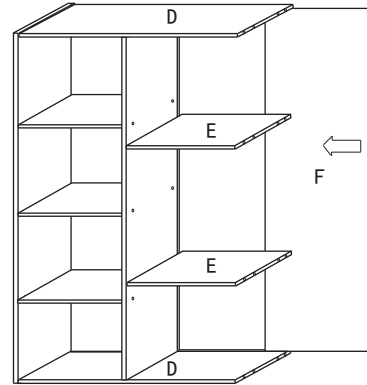

#### STEP 6

Attach Right Side Panel (B) to assembled unit using Screw (1), Dowel (2) as shown.

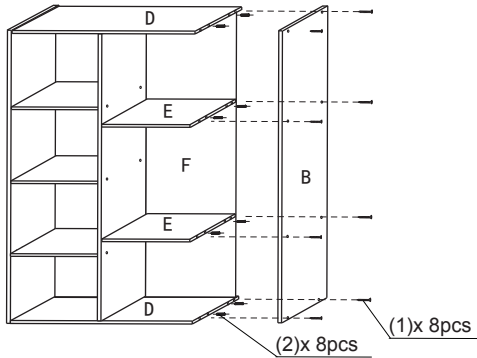

#### STEP 7

7.1 Attach Back Panel (F) to the back of assembled unit using L-Support/ Screw (3).  
7.2 Cover screw head with Sticker (4).

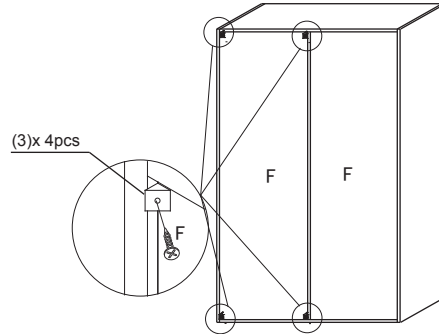

#### Recommended Maximum Weight

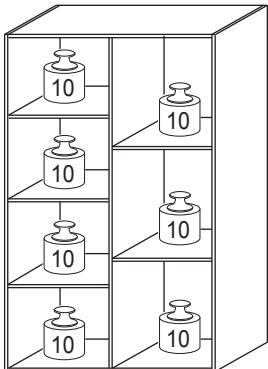

\*Unit in Pound(lbs)

#### **WARNING:**

>This unit has been designed to support the maximum loads shown. Exceeding these load limits could cause sagging, instability, product collapse, and/or serious injury.

>DO NOT allow children to climb on unit.

>Put heavier items on lower shelves.



## **Assembly Instruction**

Furinno 7-Cube Open Shelf  
MODEL : 11048WH

00:30

Approx. 30 minutes



Recomm. 2 Person



Tool Required

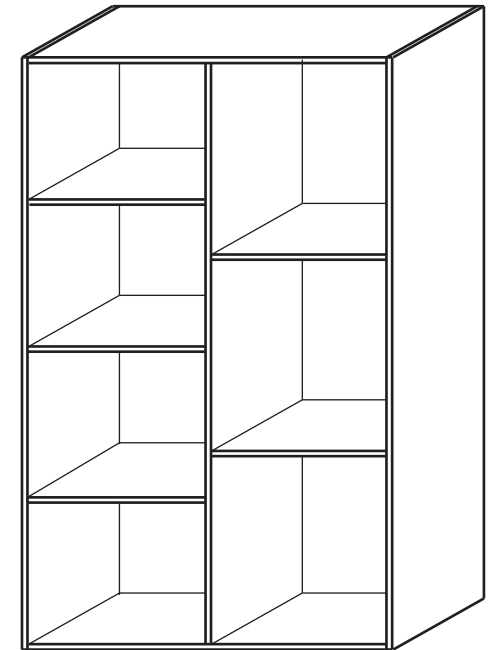











#### **Customer Support**

**NEED HELP?** For replacement requests or product inquiries, please contact our Customer Service Team by emailing us at [support@furinno.com](mailto:support@furinno.com). Thank you for selecting Furinno!

[www.furinno.com](http://www.furinno.com)



No	Hardware List	Qty
1	Screw 	28pcs
2	Dowel 	32pcs
3	L-Support/ Screw 	4pcs
4	Sticker 	18pcs
5	Cam-Lock Screw/Nut 	2pcs

No	Parts List	Qty
A	Left Side Panel 	1pc
B	Right Side Panel 	1pc
C	Center Panel 	1pc
D	Top/ Bottom Panel 	2pcs
E	Shelf Panel 	5pcs
F	Back Panel 	2pcs

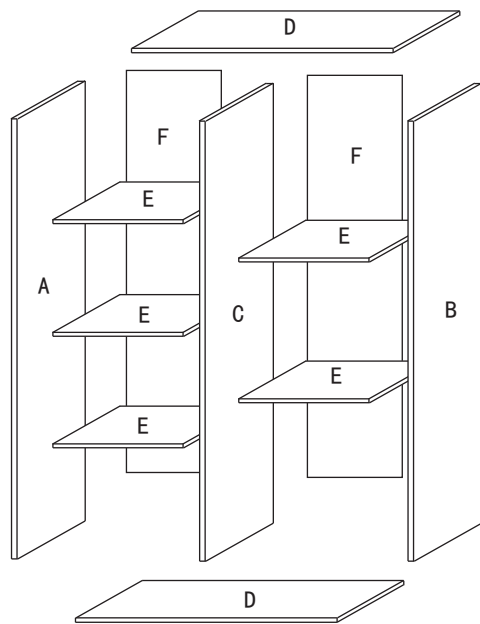

#### USEFUL HINTS BEFORE YOU START:

1. Read each step carefully before starting.
2. It is important that each step is performed in correct order to avoid difficulties.
3. Identify, sort and count the parts before assembly.
4. Assemble your furniture on packaging cardboard to prevent scratch or damage.
5. Clean the product with mild cleanser using soft damped cloth. Do not use harsh or abrasive cleanser.
6. Using incompatible hardware might cause damage to product.

#### STEP 1

Attach three Shelf Panel (E) to Center Panel (C) using Screw (1) and Dowel (2), as shown.

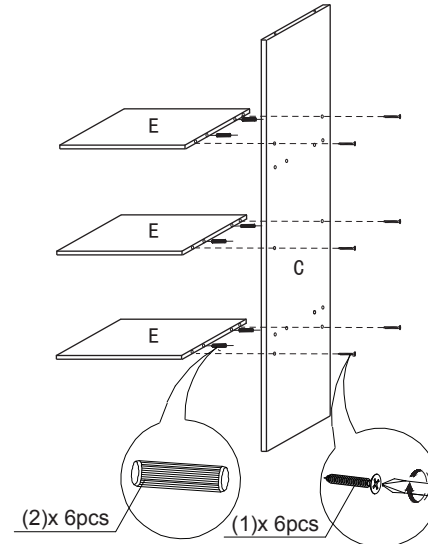

#### STEP 2

Attach another two Shelf Panel (E) to the other side of Center Panel (C) using Screw (1) and Dowel (2), as shown.

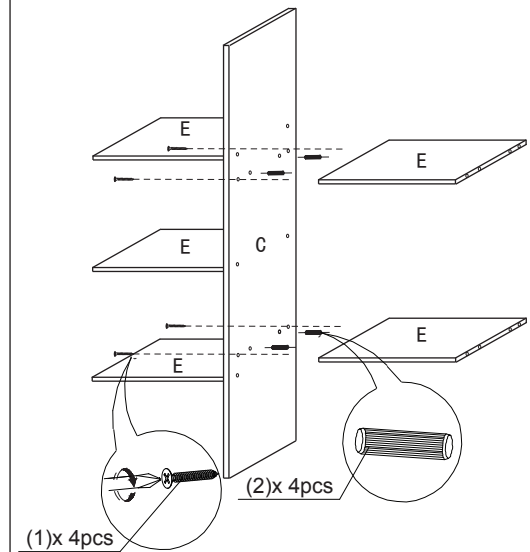

#### STEP 3

- 3.1 Attach Bottom Panel (D) to Center Panel (C) using Dowel (2) and Cam-Lock Screw/Nut (5).
- 3.2 Insert Back Panel (F) and Left Side Panel (A) to the assembled unit using Screw (1) and Dowel (2) as shown.

