

USE AND CARE GUIDE

LED PUCK LIGHTS

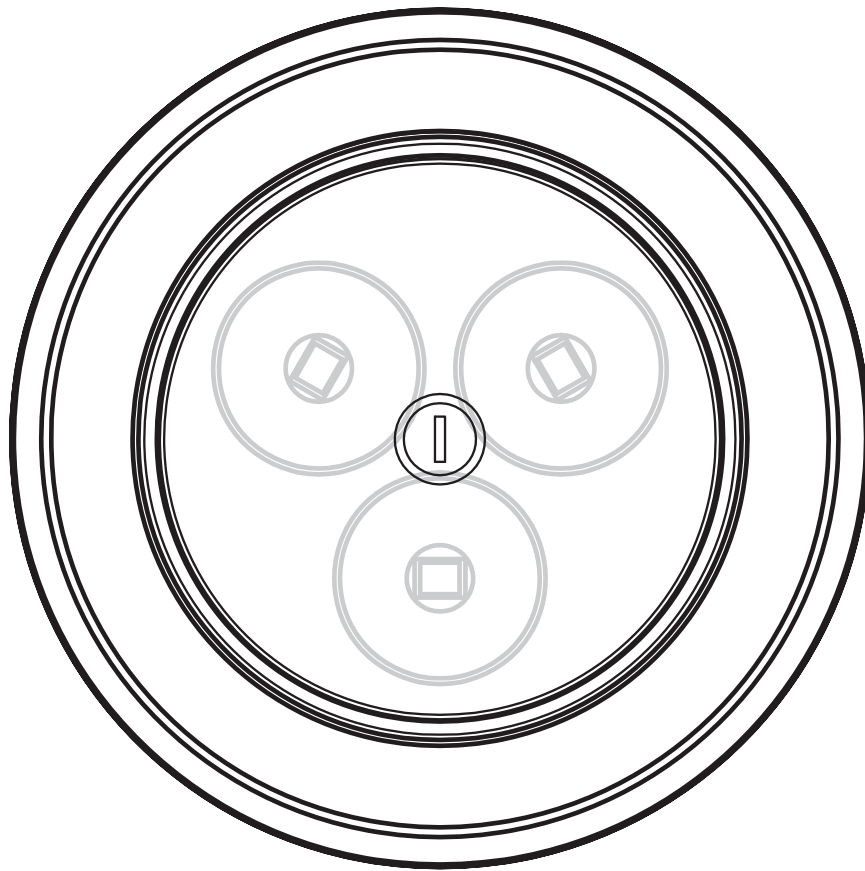

Questions, problems, missing parts? Before returning to the store,
call Commercial Electric Customer Service
8 a.m. - 6 p.m., EST, Monday - Friday

1-877-527-0313

HOMEDEPOT.COM

THANK YOU

We appreciate the trust and confidence you have placed in Commercial Electric through the purchase of this light fixture. We strive to continually create quality products designed to enhance your home. Visit us online to see our full line of products available for your home improvement needs. Thank you for choosing Commercial Electric!

Table of Contents

Table of Contents	2	Package Contents	3
Safety Information.....	2	Installation	4
Warranty.....	2	Operation	5
Pre-Installation	2	Care and Cleaning	5
Planning Installation.....	2		

Safety Information

- Consult a qualified electrician if you have any electrical questions.



CAUTION: BATTERY PRECAUTIONS

- Use only the size and type of batteries specified.
- Always purchase the correct size and grade of battery most suitable for the intended use.
- Be sure to follow the correct polarity when installing the batteries as indicated in the battery compartment. Reversed batteries may cause damage to the device.
- Do not mix alkaline, standard (Carbon-Zinc), or rechargeable (Nickel Cadmium) batteries.
- Replace all batteries of a set at the same time. Do not mix old and new batteries.
- Clean the battery contacts and also those of the device prior to battery installation.
- Do not dispose of batteries in fire.
- Remove batteries if consumed or if product is to be left unused for an extended period of time.

Warranty

The manufacturer warrants this lighting fixture to be free from defects in materials and workmanship for a period of three (3) years from date of purchase. This warranty applies only to the original consumer purchaser and only to products used in normal use and service. If this product is found to be defective, the manufacturer's only obligation, and your exclusive remedy, is the repair or replacement of the product at the manufacturer's discretion, provided that the product has not been damaged through misuse, abuse, accident, modifications, alterations, neglect, or mishandling. This warranty shall not apply to any product that is found to have been improperly installed, set-up, or used in any way not in accordance with the instructions supplied with the product. This warranty shall not apply to a failure of the product as a result of an accident, misuse, abuse, negligence, alteration, faulty installation, or any other failure not relating to faulty material or workmanship. This warranty shall not apply to the finish on any portion of the product, such as surface and/or weathering, as this is considered normal wear and tear. The manufacturer does not warrant and specially disclaims any warranty, whether express or implied, of fitness for a particular purpose, other than the warranty contained herein. The manufacturer specifically disclaims any liability and shall not be liable for any consequential or incidental loss or damage, including but not limited to any labor / expense costs involved in the replacement or repair of said product.

Contact the Customer Service Team at 1-877-527-0313 or visit www.homedepot.com.

Pre-Installation

PLANNING INSTALLATION

- Read all instructions before assembly.
- To avoid damaging this product, assemble it on a soft, non-abrasive surface, such as carpet or cardboard.
- Keep your receipt and these instructions for proof of purchase.

Pre-Installation (continued)

HARDWARE INCLUDED

 **NOTE:** Hardware not shown to actual size.



Part	Description	Quantity
AA	Mounting screw	6
BB	Double-sided tape	3

PACKAGE CONTENTS

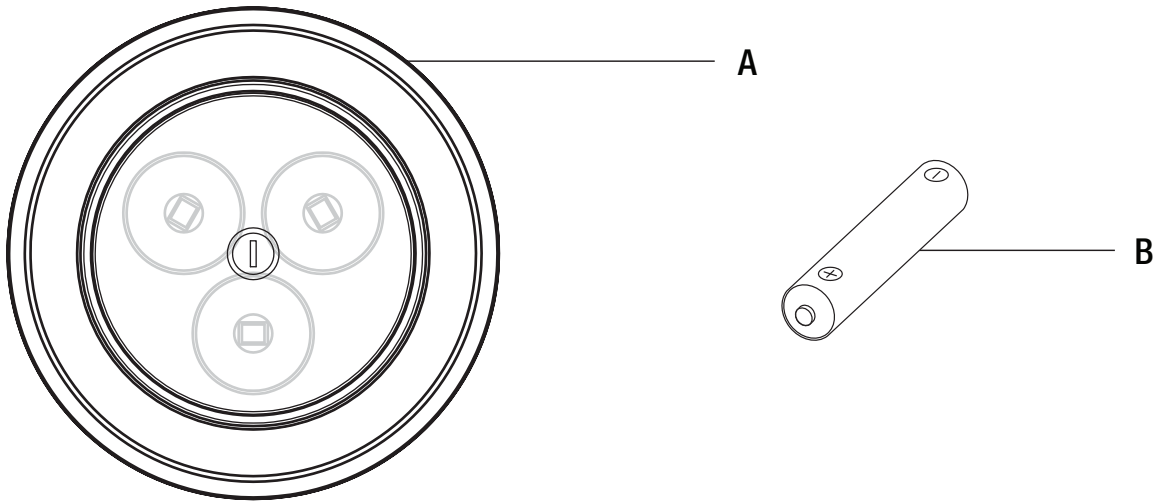

Part	Description	Quantity
A	Light fixture	3
B	AAA battery	9

Installation

1 Installing double-sided tape

NOTE: If you wish to mount the light with screws, proceed to Step 2.

- Check the location of where you want to place the puck light. Make sure it is clean and that there is no debris or dust.
- Remove the protective film from one side of the double-sided tape (BB) and apply to the center of the mounting bracket (battery door). Peel off the remaining protective film and press the mounting bracket firmly to the intended surface.



CAUTION: Be cautious of what surface the double-sided tape is attached to, as it may remove paint or damage the surface.

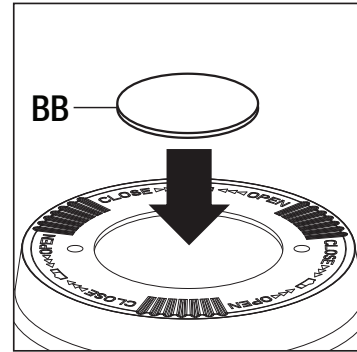

2 Mounting with screws

- If previously installed, remove the double-sided tape by pulling the tape away from the base of the light.
- Rotate the mounting bracket (battery cover) counterclockwise and remove it.
- Drill two (2) pilot holes in the location where you want to mount the puck light. Use the mounting bracket as a guide for the pilot holes.
- Place the screws (AA) in pre-drilled holes. Do not over tighten.
- Clip the puck light to the mounting bracket by aligning and inserting the posts on the bracket into the slots on the backside of the puck light, then rotating it clockwise to lock in place.

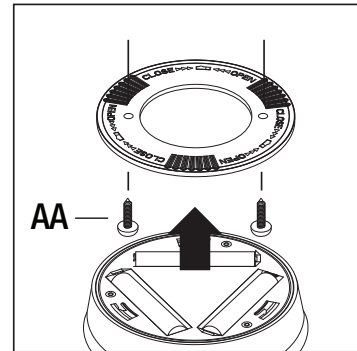

3 Removing the battery cover

- Rotate the battery cover counterclockwise and remove it.

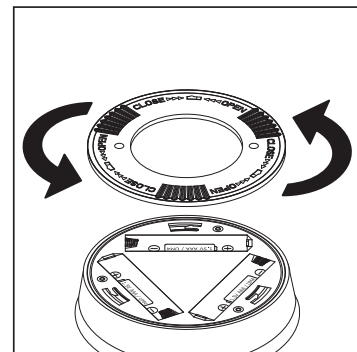

Installation (continued)

4 Replacing the batteries

- If the LEDs appear to be dim, this is an indication that your batteries need to be replaced.
- Rotate the battery cover counterclockwise and remove it.
- Remove the old batteries and insert three new AAA batteries (B). Be sure to match the polarity as shown in the diagram in the battery compartment.
- Check light operation to confirm that batteries are correctly installed.
- Replace the battery cover and rotate it clockwise to lock it in place.

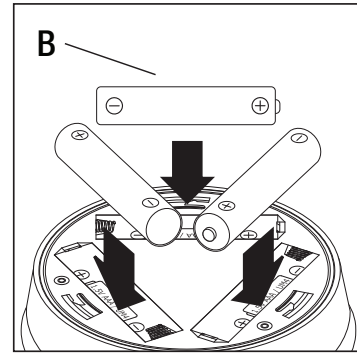

CAUTION: Do not mix battery types. Use only fresh batteries. Alkaline are recommended.

Operation

1 Removing the tab

- Remove the clear plastic tab by pulling away from the light.

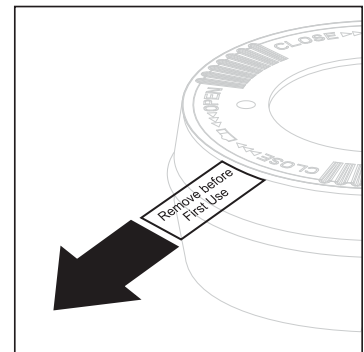

2 Turning the light on

- Press the light once for full brightness. Press again to turn the light off.

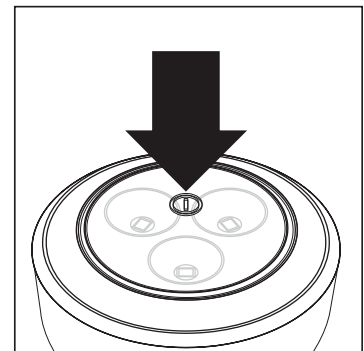

Care and Cleaning

- Clean the lamp with a soft, dry cloth.
- Do not use any cleaners with chemicals, solvents, or harsh abrasives.



**Questions, problems, missing parts?
Before returning to the store, call Commercial Electric Customer Service
8 a.m. - 6 p.m., EST, Monday-Friday**

1-877-527-0313

HOMEDEPOT.COM

Retain this manual for future use.