

Z Series

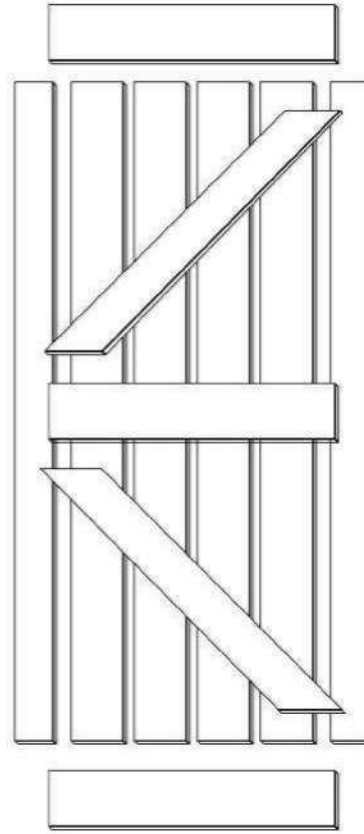

K Series



Avoid direct sunlight.
Avoid moisture.
Avoid rain.



Tools needed for assembly.



Assembly with a partner recommended.
Wear working gloves.

Z Series

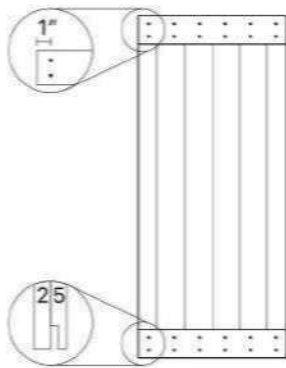
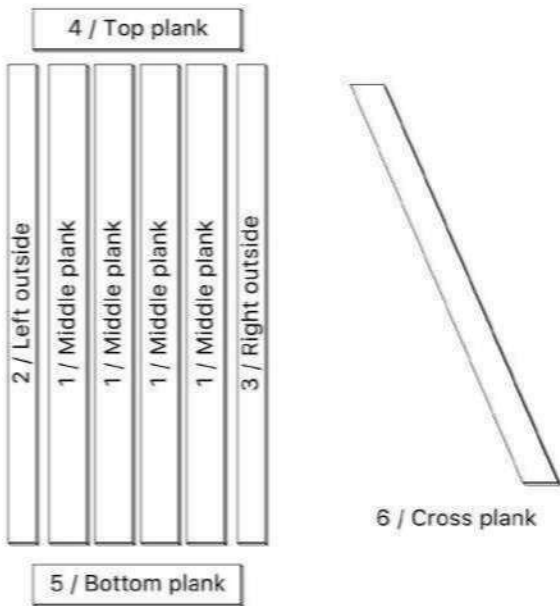

Side view:

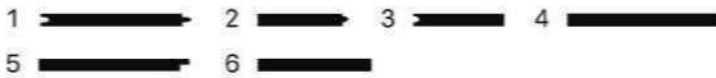

Remarks: The quantity of (No. 1 middle board) will vary depending on the size of the product.

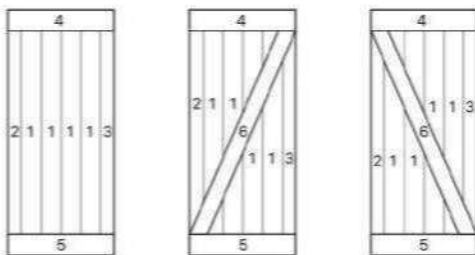

Please decide the appearance before assemble.

K Series

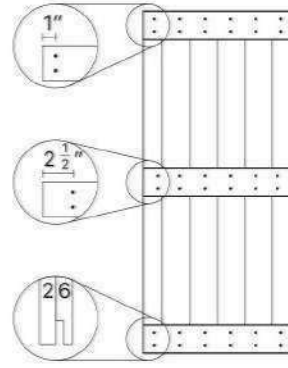
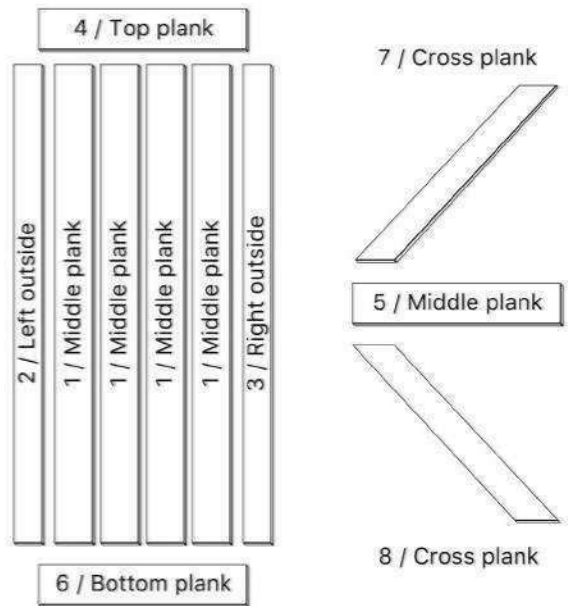

Side view:

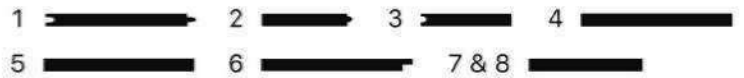

Remarks: The quantity of (No. 1 middle board) will vary depending on the size of the product.

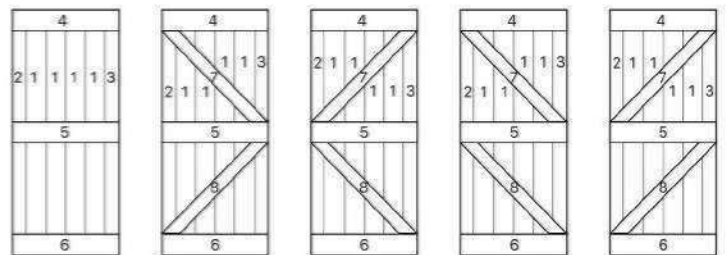

Please decide the appearance before assemble.

Z Series

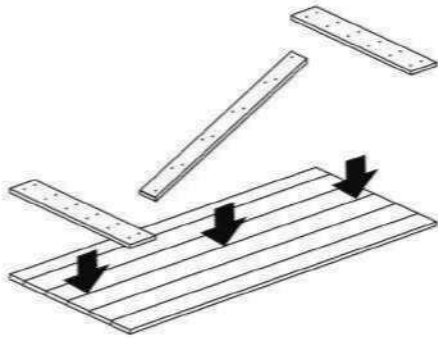

Step 1: Combine lower planks.

Step 2: Combine upper and lower planks.

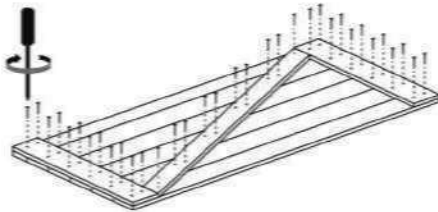

Step 3: Lock all the screws.

Remarks: The quantity of screw holes and screws will vary depending on the size of the product.

K Series

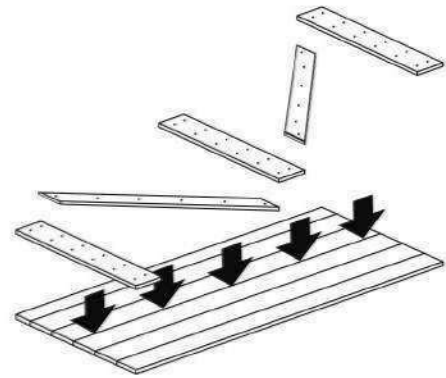

Step 1: Combine lower planks.

Step 2: Combine upper and lower planks.

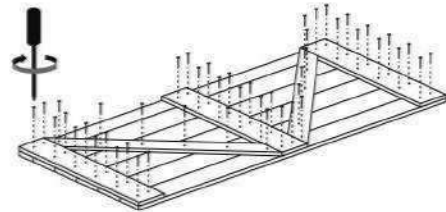

Step 3: Lock all the screws.

Remarks: The quantity of screw holes and screws will vary depending on the size of the product.

Instruction for installing door and track

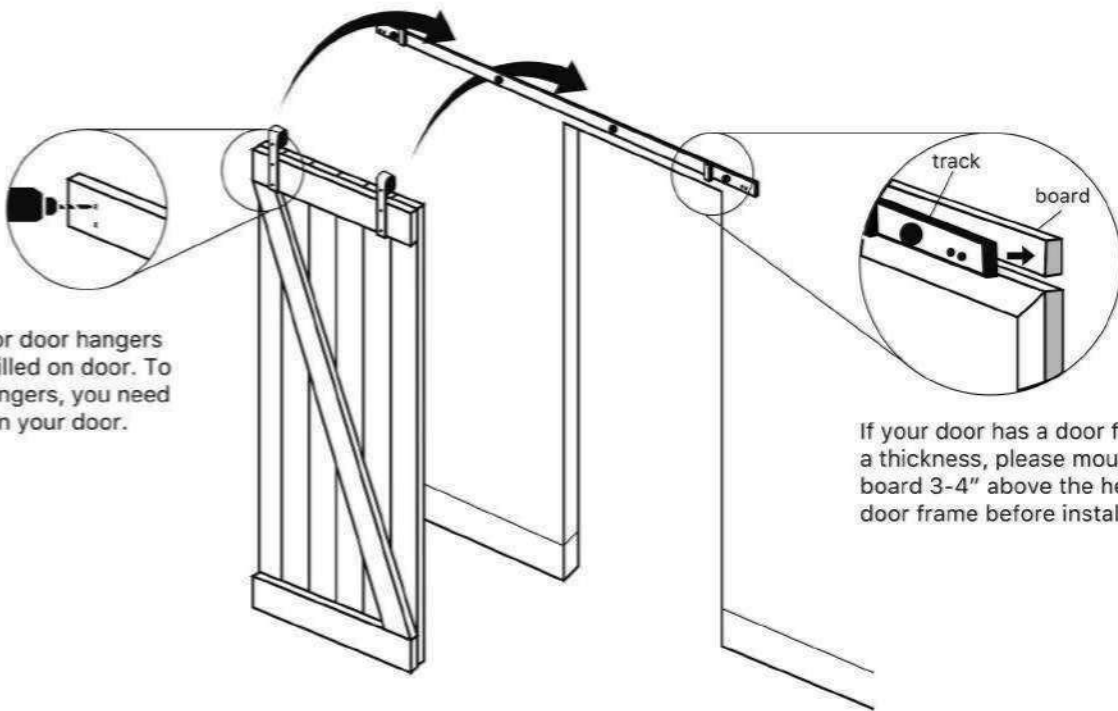

Screw holes for door hangers are not pre-drilled on door. To install door hangers, you need to drill holes on your door.

If your door has a door frame that has a thickness, please mount a wooden board 3-4" above the header of your door frame before installing track.

* To assemble sliding door track, see track installation manual.



COAST SEQUOIA INC

KNOTTY PINE BARN DOOR

Instruction for assembling