

# XTREME POWER US

2200W DEMOLITION JACK HAMMER WITH SCRAPPING CHISEL

ITEM #61118-XP



## OWNER'S MANUAL AND SAFETY INSTRUCTIONS

SAVE THIS MANUAL: KEEP THIS MANUAL FOR SAFETY WARNINGS, PRECAUTIONS, ASSEMBLY, OPERATING, INSPECTION, MAINTENANCE AND CLEANING PROCEDURES. WRITE THE PRODUCT'S SERIAL NUMBER ON THE BACK OF THE MANUAL NEAR THE ASSEMBLY DIAGRAM (OR MONTH AND YEAR OF PURCHASE IF PRODUCT HAS NO NUMBER).

FOR QUESTIONS PLEASE CALL OUR CUSTOMER SUPPORT: (909) 628 0880 MON-FRI 9AM TO 3PM PST



## GENERAL SAFETY WARNINGS

Read all safety warnings and instructions. Failure to follow the warnings and instructions may result in electric shock, fire and/or serious injury. Save all warnings and instructions for future reference.

## SAFETY

---

The warnings, precautions, and instructions discussed in this instruction manual cannot cover all possible conditions and situations that may occur. It must be understood by the operator that common sense and caution are factors which cannot be built into this product, but must be supplied by the operator. Read carefully and understand all ASSEMBLY AND OPERATION INSTRUCTIONS before operating. Failure to follow the safety rules and other basic safety precautions may result in serious personal injury.

- **Read and understand all instructions.** Failure to follow all instructions may result in serious injury or property damage.
- **DO NOT** allow persons to operate or assemble the product until they have read this manual and have developed a thorough understanding of how it works.
- **DO NOT modify this product in any way.** Unauthorized modification may impair the function and/or safety and could affect the life of the product. There are specific applications for which the product was designed.
- **Use the right tool for the job. DO NOT** attempt to force small equipment to do the work of larger industrial equipment. There are certain applications for which this equipment was designed. This product will be safer and do a better job at the capacity for which it was intended. **DO NOT** use this equipment for a purpose for which it was not intended.
- **Keep children and bystanders away from the work area while operating the tool. DO NOT** allow children to handle the product.
- **DO NOT** operate power tools in explosive atmospheres, such as in the presence of flammable liquids, gases or dust. Power tools create sparks which may ignite the dust or fumes
- Power tool plugs must match the outlet. Never modify the plug in any way. **DO NOT** use any adapter plugs with grounded power tools. Unmodified plugs and matching outlets will reduce risk of electric shock.
- Avoid body contact with grounded surfaces such as pipes, radiators, ranges and refrigerators. There is an increased risk of electric shock if your body is grounded.
- **DO NOT** expose power tools to rain or wet conditions. Water entering a power tool will increase the risk of electric shock.
- **DO NOT** abuse the cord. Never use the cord for carrying, pulling or unplugging the power tool. Keep cord away from heat, oil, sharp edges or moving parts. Damaged or entangled cords increase the risk of electric shock.
- When operating a power tool outdoors, use an extension cord suitable for outdoor use. Use of a cord suitable for outdoor use reduces the risk of electric shock.
- If operating a power tool in a damp location is unavoidable, use a Ground Fault circuit Interrupter (GFCI) protected supply.

# IMPORTANT SAFETY INFORMATION

- Stay alert, watch what you are doing and use common sense when operating a power tool. **DO NOT** use a power tool while you are tired or under the influence of drugs, alcohol or medication. A moment of inattention while operating power tools may result in serious personal injury.
- Use personal protective equipment. Always wear eye protection. Safety equipment such as dust mask, non-skid safety shoes, hard hat, or hearing protection used for appropriate conditions will reduce personal injuries
- Prevent unintentional starting. Ensure the Switch is in the off-position before connecting to power source, picking up or carrying the tool. Carrying power tools with your finger on the Switch or energizing power tools that have the Switch on invites accidents.
- **DO NOT** overreach. Keep proper footing and balance at all times. This enables better control of the power tool in unexpected situations.
- Dress properly. **DO NOT** wear loose clothing or jewellery. Keep your hair, clothing and gloves away from moving parts. Loose clothes, jewellery or long hair can be caught in moving parts.
- If devices are provided for the connection of dust extraction and collection facilities, ensure these are connected and properly used. Use of these devices can reduce dust-related hazards.
- Only use safety equipment that has been approved by an appropriate standards agency. Unapproved safety equipment may not provide adequate protection. Eye protection must be ANSI-approved and breathing protection must be NIOSH-approved for the specific hazards in the work area.
- **DO NOT** force the power tool. Use the correct power tool for your application. The correct power tool will do the job better and safer at the rate for which it was designed.
- **DO NOT** use the power tool if the Switch does not turn it on and off. Any power tool that cannot be controlled with the Switch is dangerous and must be repaired.
- Disconnect the plug from the power source before making any adjustments, changing accessories, or storing power tools. Such preventive safety measures reduce the risk of starting the power tool accidentally.
- Store idle power tools out of the reach of children and do not allow persons unfamiliar with the power tool or these instructions to operate the power tool. Power tools are dangerous in the hands of untrained user.
- Maintain power tools. check for misalignment or binding of moving parts, breakage of parts and any other condition that may affect the power tool's operation. If damaged, have the power tool repaired before use. Many accidents are caused by poorly maintained power tools.
- Keep cutting tools sharp and clean. Properly maintained cutting tools with sharp cutting edges are less likely to bind and are easier to control.
- Use the power tool, accessories and tool bits etc. in accordance with these instructions, taking into account the working conditions and the work to be performed. Use of the power tool for operations different from those intended could result in a hazardous situation.
- **DO NOT** operate this tool if you have back, neck, or wrist injuries, or other conditions that will be aggravated by the severe jerking forces that this tool exerts upon the operator.
- **DO NOT** lay the tool down until it has come to a complete stop. Moving parts can grab the surface and pull the tool out of your control.
- People with pacemakers should consult their physician(s) before use. Electromagnetic fields near heart pacemakers could cause pacemaker interference or pacemaker failure. In addition, people with pacemakers should:
  - Avoid operating alone.
  - Properly maintain and inspect to avoid electrical shock.
  - Properly ground power cord. Ground Fault Circuit Interrupter (GFCI)

# IMPORTANT SAFETY INFORMATION

- Hold power tools by insulated gripping surfaces when performing an operation where the cutting tool may contact hidden wiring or its own cord. Contact with a "live" wire will make exposed metal parts of the tool "live" and shock the operator.
- **Keep clear of moving parts.**
- **Avoid unintentional starting.** Prepare to begin work before turning on the tool.
- **DO NOT** leave the tool unattended when it is plugged into an electrical outlet. Turn off the tool and unplug it from its electrical outlet before leaving.
- Anyone using vibrating tools regularly or for an extended period should first be examined by a doctor and then have regular medical check-ups to ensure medical problems are not being caused or worsened from use. pregnant women or people who have impaired blood circulation to the hand, past hand injuries, nervous system disorders, diabetes, or Raynaud's Disease should not use this tool. If you feel any symptoms related to vibration (such as tingling, numbness, and white or blue fingers), seek medical advice as soon as possible.
- **DO NOT smoke during use.** Nicotine reduces the blood supply to the hands and fingers, increasing the risk of vibration-related injury.
- Wear suitable gloves to reduce the vibration effects on the user.
- To reduce vibration, maintain the tool as explained in this manual. If any abnormal vibration occurs, stop use immediately.



**SAVE THESE WARNINGS**

# PRODUCT INFORMATION

This XtremePowerUS Jack Hammer is ideal for demolition, trenching, chipping, breaking holes in concrete-block-brick, removing foundation concrete slab, chimney and so on. It features heavy duty construction with industrial quality for high durability. It enables you to operate smoothly without hard feeling. It comes along with 360 degree swivel handle with slip prevent grip for stable grips. The carrying case is easy for stocking and carrying.

## FEATURES

- Voltage: 120 V/60Hz
- Motor: Heavy Duty 2,200W Motor
- No Load Speed: 1,900 RPM
- Material: Heavy Duty Steel Case
- 360 Degrees Swivel Side Handle
- High Velocity Toughened Crank Shaft
- Simply lock it in & Use at Any Angle

## PACKAGE CONTENTS

- 16" Bull Point Chisel (1-1/8")
- 16" Flat Chisel (1-1/8")
- Bottle w/ 2 caps
- 3 Pcs Hex Keys
- Scrapping Chisel
- Carrying Case
- High Impact Case with 2 Wheels & Handle

**APPLICATIONS:** Crushing concrete, chipping, digging and squaring. Installation of piping and wiring, sanitary facility installation, machinery installation, water supply drainage work, interior jobs and other civil engineering work.



**Assembled Product Dimensions (L x W x H) 31.00 x 8.00 x 14.00 Inches**

### STANDARD ACCESSORIES

STEEL CASE	X1
BULL POINT (TOTAL LENGTH 410mm)	X1
OIL FEEDER	X1
HEXAGON BAR WRENCH	X2
WRENCH	X1

Standard accessories are subject to change without notice

### SPECIFICATIONS

VOLTAGE BY AREAS	120V
INPUT	2200W
FULL LOAD IMPACT RATE	1400/MIN
WEIGHT (WITHOUT CORD)	15KG

Be sure to check the nameplate on the product as it is subject to change by area

# OPERATION

## WORK AREA SET UP

1. Designate a work area that is clean and well-lit. The work area must not allow access by children or pets to prevent distraction and injury.
2. Route the power cord along a safe route to reach the work area without creating a tripping hazard or exposing the power cord to possible damage. The power cord must reach the work area with enough extra length to allow free movement while working.
3. Secure loose work pieces using a vise or clamps (not included) to prevent movement while working.
4. There must not be objects, such as utility lines, nearby that will present a hazard while working.

## PRIOR TO OPERATION

1. **POWER SOURCE:** Ensure that the power source to be utilized conforms to the power requirements specified on the product nameplate.
2. **GROUNDING:** This tool should be grounded while in use to protect the operator from electric shock. This tool is equipped with a three-conductor cord and grounding plug to fit the proper grounding receptacle. The green (or green and yellow) conductor in the cord is the grounding wire. Never connect the green (or green and yellow) wire to a live terminal.
3. **POWER SWITCH:** Ensure that the power switch is in the OFF position. If the plug is connected to a power receptacle while the power switch is the ON position. The power tool will start operating immediately, possible causing serious injury.
4. **EXTENSION CORD:** Use an extension cord of sufficient thickness and rated capacity. The extension cord should be kept as short as possible.
5. **FEEDING OIL:** Prior to using the power tool, remove the oil gauge. This product contains only a small amount of oil when shipped from the factory.

**MOUNTING A TOOL:** Standard tools are recommended for proper operation.

1. Rotate the Stop Lever 180° in a clockwise direction while pulling toward you. Next, insert the tool shank into the hexagonal hole on the front cover.
2. Clamp the tool by turning the stop lever half a turn in the opposite direction.

**Note:** When removing the tool, follow the above procedure in reverse order.

## USING THE HAMMER

1. After placing the tip of the tool in the base, turn power witch to ON. In some cases, it may be necessary to push up a bit against the crushing position forcefully in order to begin the striking stroke. This is not due to a malfunction of the tool, it means the safe-guard mechanism against no-load striking is working.
2. By utilizing the weight of the machine and by firmly holding the hammer with both hands, one can effectively control the subsequent recoil motion. Proceed at a moderate work rate. The use of too much force can impair efficiency.

**CAUTION:** Sometime the tool does not begin the striking stroke even when the motor rotates because the oil has thickened. If this tool is used in low temperatures or if it being used after extended idle time. To avoid this, run the tool for five minutes to warm it up before use.

**BEFORE EACH USE:** Inspect the general condition of the tool. Check for loose hardware, misalignment or binding of moving parts, damaged cord/electrical wiring, dull or cracked Chisel, cracked or broken parts, and any other condition that may affect its safe operation. After use, wipe external surfaces of the tool with clean cloth

# OPERATION

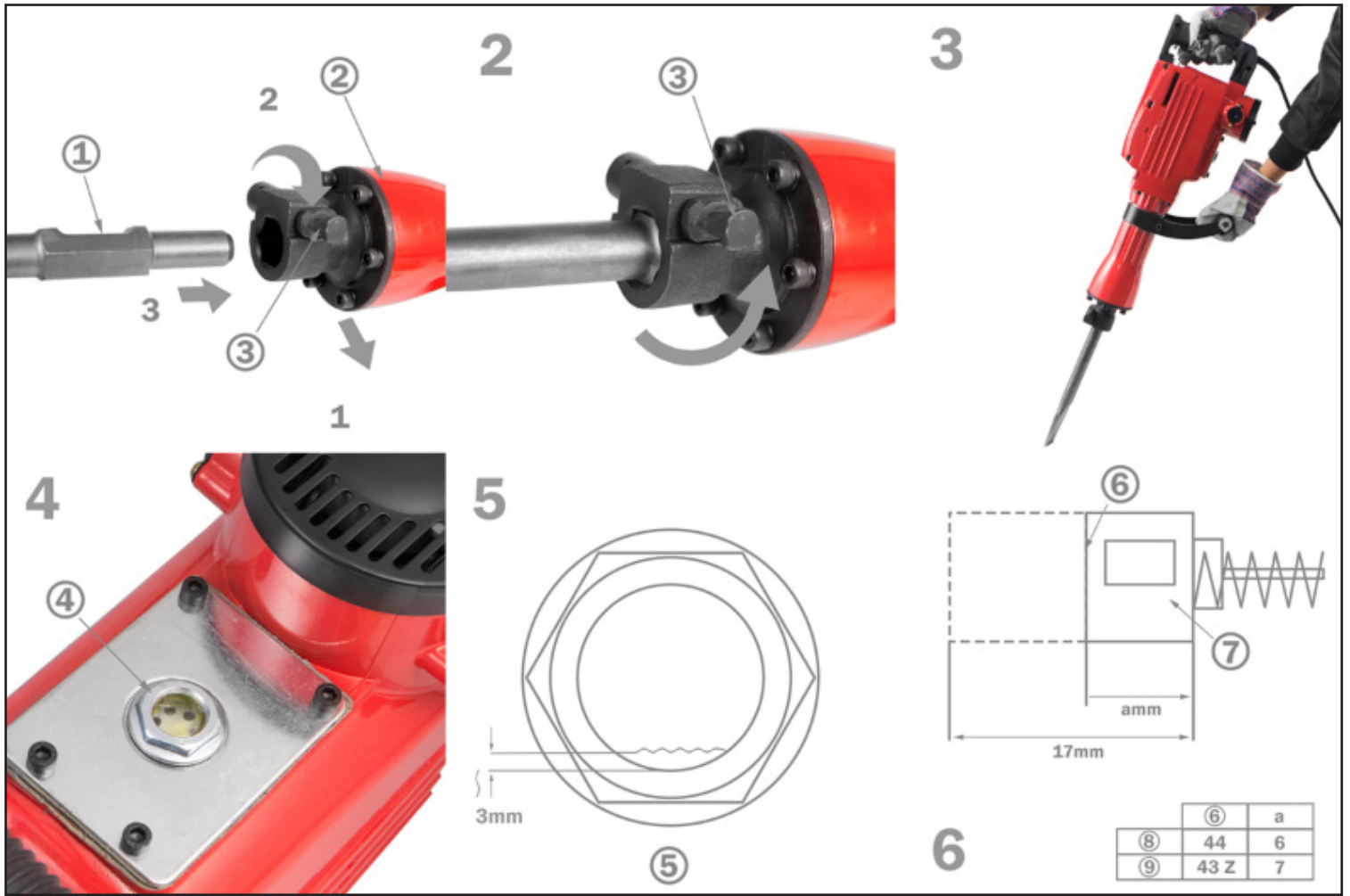

1. Hold the tool with it's flattened part directed upward.

2. Front Cover

3. Stop Lever

4. Oil Gauge, check the oil quantity by holding the body upright.

5. Resupply oil when the oil level drops to less than approx. 3mm

6. Wear limit

7. Number of Carbon Brush

8. Usual Carbon Brush

9. Auto-Stop Carbon Brush

## OIL FEEDING

**CAUTION:** Prior to oil feeding, always disconnect to plug from the power supply. Since an oil chamber is built into this tool it can be used for approximately 20 days without needing to supply lubricating oil, assuming the tool is used continuously 3-4 hours a day. Feed oil into the oil tank as described below using this tool.

1. Just before oil is no longer visible in the oil gauge window when holding this device upright, be sure to refill oil.
2. Before feeding oil, use the provided wrench to remove the oil gauge. Be careful not to lose the rubber packing attached below the oil gauge.
3. Check the oil level once daily to confirm the oil is filled.
4. After filling the oil, be sure to securely clamp the oil gauge closed.

## MAINTENANCE AND INSPECTION

**1. Inspecting the Tool:** Use of a dull attachment can cause motor malfunction and degrade efficiency. Replace with a new attachment when abrasions or dullness is noticed.

**2. Inspecting the Mounting Screws:** Regularly inspect all mounting screws and ensure that they are properly tightened. Re-tighten any loose screws immediately before use. Failure to do so can cause serious injury.

**3. Maintenance of the Motor:** The motor unit winding is an integral part of the power tool. Exercise care to ensure the motor does not become damaged or in contact with water. Failure to do so can cause serious damage and injury.

**4. Inspecting Carbon Brushes:** The motor employs carbon brushes which can become worn over time and can result in motor trouble. When the auto-stop carbon brush is activated the motor will automatically stop. If this happens, replace worn carbon brushes with new ones. In addition, always keep carbon brushes clean and ensure they slide freely within the brush holders. The carbon brushes can be removed by removing the cap cover. Cap rubber and brush cap in that order at the interior.

**Notice:** Due to continued research and development, the specifications herein are subject to change without notice.



# PARTS DIAGRAM

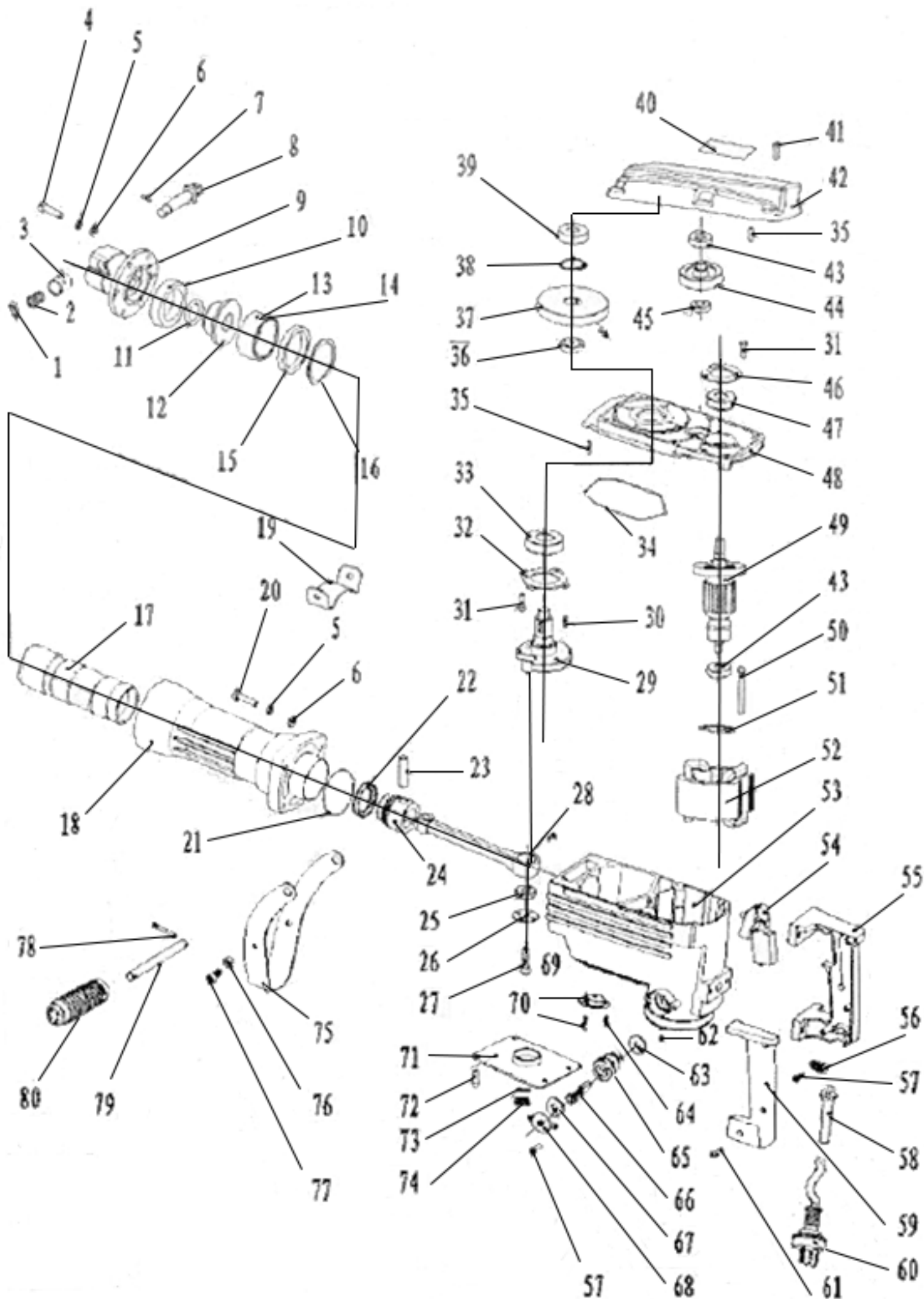

# PARTS LIST

MODELS: 61108 / 61108-XP

MODEL DESCRIPTION: DEMOLITION JACK HAMMER

ITEM	DESCRIPTION	QTY	ITEM	DESCRIPTION	QTY
1	TOOL HOLDER	1	50	REAR COVER	1
2	TOOL RETAINER	1	51	HEX SOCKET HEAD BOLT M5X12	2
002-1	TOOL RETAINER	1	52	HEX SOCKET HEAD BOLT M10X40	1
3	HEX SOCKET HEAD BOLT M8X30	6	53	CRANK SLEEVE	1
4	COMPRESSION SPRING 17	1	54	NEEDLE ROLLER BEARING	1
004-1	COMPRESSION SPRING 17	1	56	CRANK SHAFT	1
5	RETAINER SLEEVE	1	57	HEX SOCKET HEAD BOLT M5X18	4
6	URETHANE RING 49	1	58	BEARING RETAINER 65	1
7	O RING 24	1	59	WOODRUFF KEY 4	2
8	SEAL HOLDER	1	60	MOTOR HOUSING COMPLETE	1
9	IDLER	1	60	BRUSH HOLDER	2
10	RUBBER SLEEVE 64	1	61	HM1306 NAME PLATE	1
11	FLAT WASHER 58	1	62	SEAL RING A	1
12	URETHANE RING 59	1	63	BALL BEARING 6205LLU	1
13	CONNECTING ROD	1	64	RING 25	1
14	PISTON	1	65	BALL BEARING 6203LLU	1
15	PIN 12	1	66	HANDLE SET	1
16	Y RING 34	1	67	BEARING RETAINER 48	1
17	HAMMER	1	68	TAPPING SCREW 4X18	3
18	O RING 65	1	69	HEX SOCKET HEAD BOLT M5X18	3
19	BARREL	1	70	PAPER WASHER	2
20	HEX SOCKET HEAD BOLT M8X35	4	71	GEAR HOUSING	1
21	GRIP 37	1	72	SEAL RING B	1
22	HEX NUT M8-13	1	73	HELICAL GEAR 65	1
23	HEX NUT M8-13	2	74	BALL BEARING 6302LLB	1
24	HANDLE CLAMP	1	75	GEAR HOUSING COVER	1
25	SIDE HANDLE	1	76	HEX SOCKET HEAD BOLT M6X50	4
26	HEX SOCKET HEAD BOLT M8X20	2	77	BALL BEARING 6201ZZ	1
27	HEX NUT M8-13	1	78	HELICAL GEAR 37 COMPLETE	1
28	RING 17	1	79	BALL BEARING 6201ZZ	1
29	RING SPRING 15	1	80	PIN 6	1
30	FAN 80	1	81	HEX SOCKET HEAD BOLT M6X50	2
31	ARMATURE ASSY 220V	1	82	FLAT WASHER 6	2
32	FLAT WASHER 12	1	83	LOCK BUTTON	1
33	BALL BEARING 6201LLB	1	84	SWITCH LEVER	1
34	BAFFLE PLATE	1	85	LOCK PLATE	1
35	+HEX BOLT M5X60	2	86	SWITCH TG71B	1
36	FIELD ASSY 220V	1	87	SWITCH BOX	1
36	RING TERMINAL	2	88	COMPRESSION SPRING 3	1
36	CONNECTOR P-2	2	89	HANDLE SET	1
36	VARNISHED POLYESTER TUBE	2	90	PAN HEAD SCREW 4X18	1
37	PIN 6	1	93	TAPPING SCREW 4X18	2
38	HOLDER SEAL	1	94	STRAIN RELIEF	1
39	FELT COMPLETE	1	96	CORD GUARD 10	1
40	HEX SOCKET HEAD BOLT M4X12	4	97	POWER SUPPLY CORD 1.0-3-5.0	1
41	SEAL RING C	1	98	HEX SOCKET HEAD BOLT M6X30	2
42	OIL TANK COVER COMPLETE	1	99	FLAT WASHER 6	2
42	INDICATION LABEL	1	100	VARNISHED POLYESTER TUBE 8-40	1
43	HEAD SOCKET HEAD BOLT M5X12	4	101	O-RING 16	1
44	OIL GAUGE	1	A01	OIL SUPPLY 100CC	1
45	CAP RUBBER	4	A02	WRENCH 23	1
46	BRUSH HOLDER CAP 7-18	2	A03	BULL POINT 30-410	1
47	A.C. CARBON BRUSH CB-204	2	A04	STEEL CARRYING CASE SET	1
48	BRUSH HOLDER CAP 7-18	2	A04	MAKITA LOGO LABEL	1
49	A.C. CARBON BRUSH CB-204	1	A04	CAUTION LABEL	1

# WARRANTY

Problem	Possible Causes	Likely Solutions
Tool will not start.	<ol style="list-style-type: none"> <li>1. Cord not connected.</li> <li>2. No power at outlet.</li> <li>3. Internal damage or wear. (Carbon brushes or switch, for example.)</li> </ol>	<ol style="list-style-type: none"> <li>1. Check that cord is plugged in.</li> <li>2. Check power at outlet. If outlet is unpowered, turn off tool and check circuit breaker. If breaker is tripped, make sure circuit is right capacity for tool and circuit has no other loads.</li> <li>3. Have technician service tool.</li> </ol>
Performance decreases over time.	<ol style="list-style-type: none"> <li>1. Accessory dull or damaged.</li> <li>2. Carbon brushes worn or damaged.</li> </ol>	<ol style="list-style-type: none"> <li>1. Keep cutting accessories sharp. Replace as needed.</li> <li>2. Have qualified technician replace brushes.</li> </ol>
Excessive noise or rattling.	Internal damage or wear. (Carbon brushes or bearings, for example.)	Have technician service tool.
Overheating.	<ol style="list-style-type: none"> <li>1. Forcing tool to work too fast.</li> <li>2. Accessory dull or damaged.</li> <li>3. Blocked motor housing vents.</li> </ol>	<ol style="list-style-type: none"> <li>1. Allow tool to work at its own rate.</li> <li>2. Keep cutting accessories sharp. Replace as needed.</li> <li>3. Wear ANSI-approved safety goggles and NIOSH-approved dust mask/respirator while blowing dust out of motor using compressed air.</li> </ol>

## PLEASE READ THE FOLLOWING CAREFULLY

THE MANUFACTURER AND/OR DISTRIBUTOR HAS PROVIDED THE PARTS LIST AND ASSEMBLY DIAGRAM IN THIS MANUAL AS A REFERENCE TOOL ONLY. NEITHER THE MANUFACTURER OR DISTRIBUTOR MAKES ANY REPRESENTATION OR WARRANTY OF ANY KIND TO THE BUYER THAT HE OR SHE IS QUALIFIED TO MAKE ANY REPAIRS TO THE PRODUCT, OR THAT HE OR SHE IS QUALIFIED TO REPLACE ANY PARTS OF THE PRODUCT. IN FACT, THE MANUFACTURER AND/OR DISTRIBUTOR EXPRESSLY STATES THAT ALL REPAIRS AND PARTS REPLACEMENTS SHOULD BE UNDERTAKEN BY CERTIFIED AND LICENSED TECHNICIANS, AND NOT BY THE BUYER. THE BUYER ASSUMES ALL RISK AND LIABILITY ARISING OUT OF HIS OR HER REPAIRS TO THE ORIGINAL PRODUCT OR REPLACEMENT PARTS THERETO, OR ARISING OUT OF HIS OR HER INSTALLATION OF REPLACEMENT PARTS THERETO.

**Record Product's Serial Number Here:** \_\_\_\_\_

**Note:** If product has no serial number, record month and year of purchase instead.

**Note:** Some parts are listed and shown for illustration purposes only and are not available individually as replacement parts.

### Questions, Problems or Missing Parts?



*Before returning to a retailer, our exceptional customer service is available to help.*

**Call Us: 909.628.0880**

**Hours of Operation: 9 to 4pm PST, Monday - Friday**

**Email: [customer@xtremepowerusa.com](mailto:customer@xtremepowerusa.com)**

**PRODUCT MADE IN CHINA**