

# Cub Cadet®

## Installation Instructions

Date: March 8, 2019

Subject: Fender Kit Installation

Model(s): Ultima Zero-Turn Tractors

### Kit Contents

- RH Fender (1) (789-03477)
- LH Fender (1) (789-03478)
- Hex Screw 5/16-18: 2.75 (4) (710-0176)
- Flange Lock Nut (4) (712-04063)

### Tools For Assembly

- 1/2" Socket Wrench
- 1/2" Open End/Box Wrench
- Torque Wrench and 1/2" Socket

### Installing Rear Fenders

**Note:** All images in this guide depict installation instructions as performed on the RH Fender (789-03477). When installing the LH Fender (789-03478), these instructions will also apply.

1. Remove the rear hex screw on one side of the upper hoop at the back of the upper tractor frame and save it to reinstall later. See Figure 1.

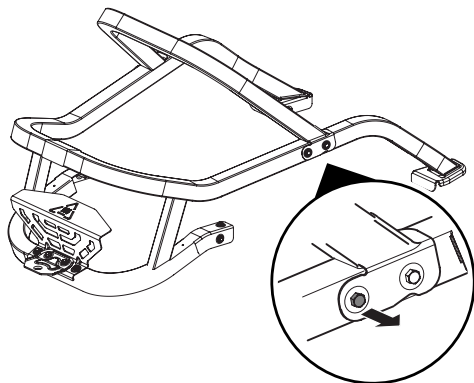

Figure 1

2. Slide the arms of the fender bracket over the upper frame just behind the upper hoop. See Figure 2.

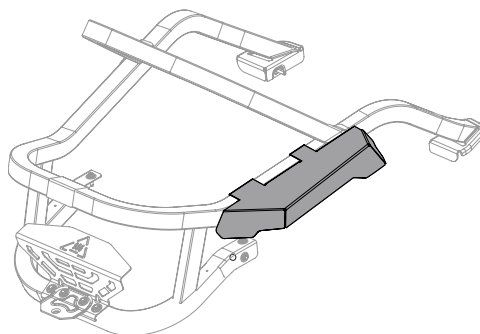

Figure 2

3. Line up the front hole of the bracket with the rear hole on the upper tractor frame and upper hoop, then reinstall the screw removed in step 1. Torque to 179-219 in lbs (20.5-24.5 N-m). See Figure 3.

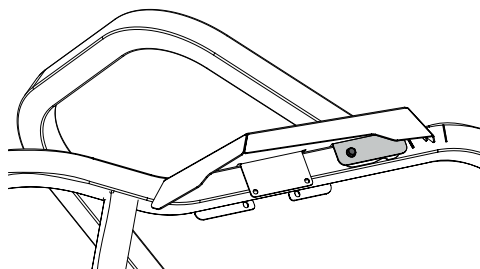

Figure 3

4. Thread two of the hex screws supplied with this kit through the holes at the bottom rear of the bracket, beneath the upper tractor frame. See Figure 4.

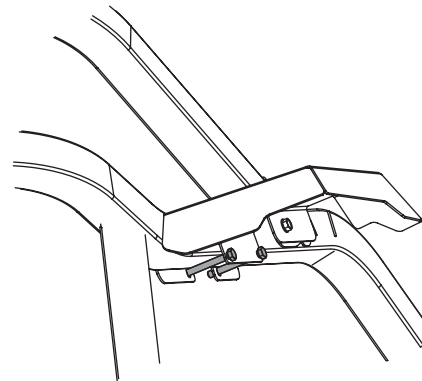

Figure 4

5. Secure the two hex screws under the frame with two of the nuts supplied with this kit. See Figure 5.

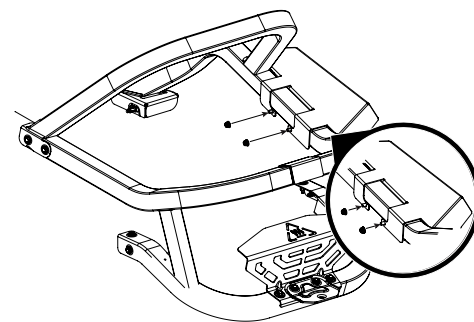

Figure 5

6. Repeat steps 1-5 on the opposite side of the tractor using the remaining hardware and side specific fender.

P.O. BOX 361131 CLEVELAND, OHIO 44136-0019



Form No. / Formulario N.º / Formulaire n.º: 769-20732A