

Over-Car Garage Shelving Unit

STRONG-TIE
DIYTM

You can find extra storage on the back wall of your garage by using the space above your car's hood. This simple, unique way of building a strong storage unit is fast and easy with 2x4 lumber and Simpson Strong-Tie® Rigid Tie® RTC2Z connectors. Custom size the width and depth to fit your particular storage needs and still have plenty of room for your vehicle.

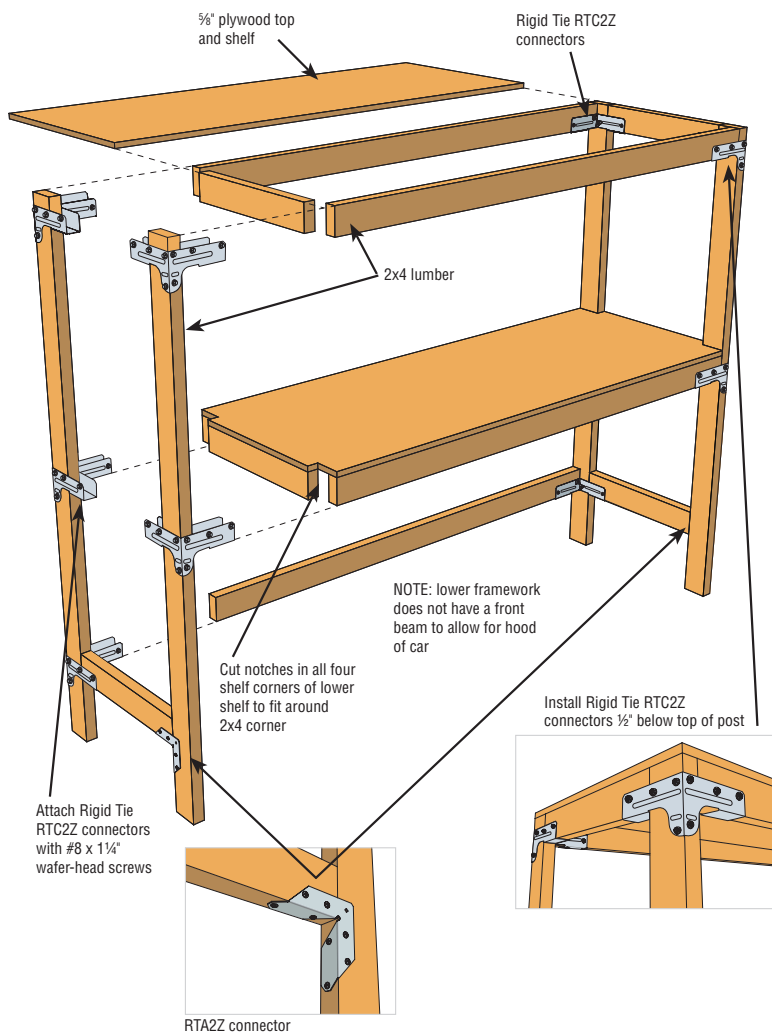

TOOLS NEEDED

- Saw
- Screw gun
- #2 Phillips-head bit
- Tape measure
- Clamps
- Framing square

Connectors are easy to install and strong enough to support even the heaviest boxes, tools or machinery, and can be finished with paint to blend with the style of your home.

INSTALLATION INSTRUCTIONS

1. Cut lumber and plywood to size.

Since all of your cuts are straight cuts, Simpson Strong-Tie connectors simplify building with wood.

2. Install connector on vertical post.

Mark height, clamp connector to post and attach with Simpson Strong-Tie #8 x 1 1/4" wafer-head screws. No predrilling is needed.

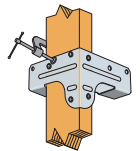

3. Connect horizontal rail on each side.

Use a clamp to help hold the wood in the seat of the connector during installation.

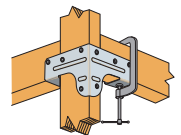

4. Notch corners of plywood shelves.

Use a piece of 2x4 on each corner of the shelf, trace and cut to accommodate corner posts.

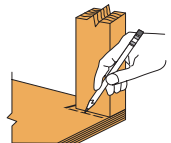

Over-Car Garage Shelving Unit

Materials and Cut Diagram

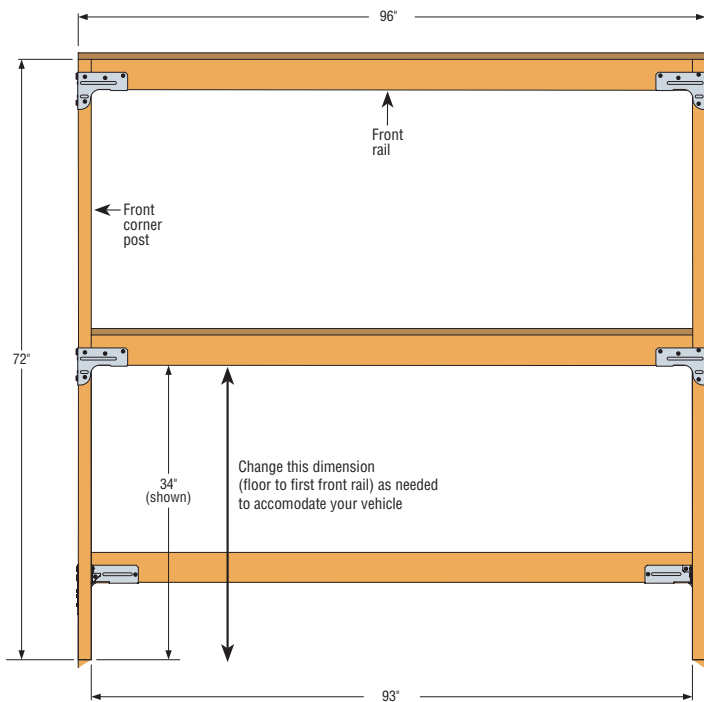

Front View

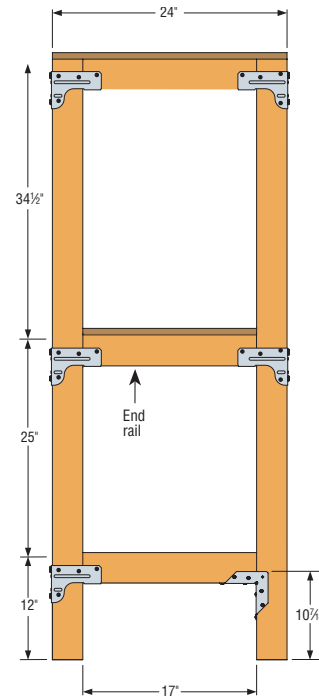

Side View

Hardware Needed



- (10) Rigid Tie® RTC2Z connectors
- (2) Rigid Tie RTA2Z connectors
- (2) Boxes Simpson Strong-Tie® #8 x 1 1/4" wafer-head screws
- (60) #6 x 1 1/4" flat-head screws

Lumber Needed

- (10) Pieces 2x4 x 8'
- (1) 4' x 8' sheet of 5/8" plywood

Cut List

Cut from 2x4 x 8'

- (5) 93" rails →  (5x)
- (4) 72" corner posts and 17" end rails →  (4x)
- (2) 17" end rails →  (1x)

Cut from 4' x 8' 5/8" plywood

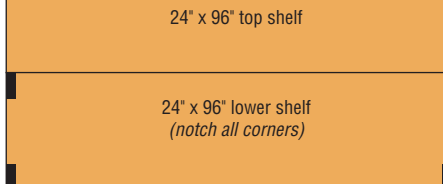
- (1) 24" x 96" top shelf →  24" x 96" top shelf
 - (1) 24" x 96" lower shelf →  24" x 96" lower shelf (notch all corners)
- Attach with #6 x 1 1/4" flat-head screws

Note: Verify vehicle width and hood height before finalizing design.

The construction plan for this project is designed to be completed by people with basic carpentry skills in standard situations. If your situation is unique, talk with someone with detailed carpentry or construction experience before starting your project. Particular attention was paid to the steps and details in this plan, but they cannot be guaranteed to be error free. Simpson Strong-Tie shall not be responsible for any possible loss, damage or injury resulting directly or indirectly from the information contained here.

(800) 999-5099
strongtie.com/diy

