

Operator's Manual

WB52BCI 2-Cycle Brush Cutter

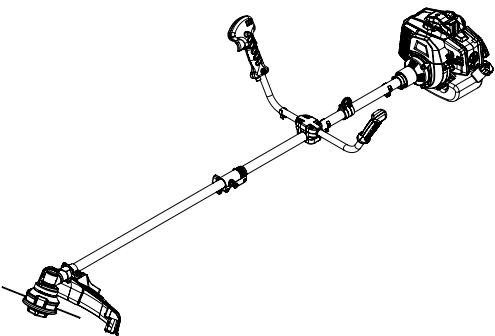

SAVE THESE INSTRUCTIONS

SERVICE

DO NOT RETURN THIS UNIT TO THE RETAILER. PROOF OF PURCHASE WILL BE REQUIRED FOR WARRANTY SERVICE.

For assistance regarding the assembly, operation or maintenance of the unit, please call **1-844-786-7335** (in the United States) or contact email box CUSTOMERSERVICE@BADGERPOWERPRODUCTS.COM

Warranty service is available through an authorized service center. To locate a service center in your area, please write us email or call the number listed above. Service on this unit, both within and after the warranty period, should only be performed by an authorized and approved service center. When servicing, use only identical replacement parts.

All information, illustrations, and specifications in this manual are based on the latest product information available at the time of printing. We reserve the right to make changes at any time without notice.

The product may vary slightly from the illustrations contained in this manual.

IMPORTANT: Read this manual thoroughly before using this product. Follow all instructions.

SAFETY

The purpose of safety symbols is to attract your attention to possible dangers. The safety symbols, and their explanations, deserve your careful attention and understanding. The safety warnings do not by themselves eliminate any danger. The instructions or warnings they give are not substitutes for proper accident prevention measures.

SYMBOL MEANING



DANGER: Signals an **EXTREME** hazard. Failure to obey a safety **DANGER** symbol **WILL** result in serious injury or death to yourself or to others.



WARNING: Signals a **SERIOUS** hazard. Failure to obey a safety **WARNING** symbol **CAN** result in serious injury to yourself or to others.



CAUTION: Signals a **MODERATE** hazard. Failure to obey a safety **CAUTION** symbol **MAY** result in property damage or injury to yourself or to others.

NOTE: Advises you of information or instructions vital to the operation or maintenance of the equipment.

SPARK ARRESTOR NOTE

NOTE: For users on U.S. Forest Land and in the states of California, Maine, Oregon and Washington. All U.S. Forest Land and the state of California (Public Resources Codes 4442 and 4443), Oregon and Washington require, by law that certain internal combustion engines operated on forest brush and/or grass-covered areas be equipped with a spark arrestor, maintained in effective working order, or the engine be constructed, equipped and maintained for the prevention of fire. Check with your state or local authorities for regulations pertaining to these requirements. Failure to follow these requirements could subject you to liability or a fine. This unit is factory equipped with a spark arrestor. If it requires replacement, contact your local service dealer to install the appropriate muffler assembly.



CALIFORNIA PROPOSITION 65

WARNING: This product contains a chemical known to the state of California to cause cancer, birth defects or other reproductive harm.

Read the operator's manual and follow all warnings and safety instructions. Failure to do so can result in serious injury to the operator and/or bystanders.

• IMPORTANT SAFETY INSTRUCTIONS •

READ ALL INSTRUCTIONS BEFORE OPERATING



WARNING: When using the unit, all safety instructions must be followed. Please read these instructions before operating the unit in order to ensure the safety of the operator and any bystanders. Please keep these instructions for later use.

- Read the instructions carefully. Be familiar with the controls and proper use of the unit.
- Do not operate this unit when tired, ill or under the influence of alcohol, drugs or medication.
- Never allow children to operate the unit. Teens must be trained, accompanied and supervised by an adult. Never allow adults to operate the unit without proper instruction.
- All guards and safety attachments must be installed properly before operating the unit.
- Inspect the unit before use. Replace damaged parts. Check for fuel leaks. Make sure all fasteners are in place and secure. Replace parts that are cracked, chipped, or damaged in any way. Do not operate the unit with loose or damaged parts.
- Only use the trimming line described in the *Specifications* section of this manual. Never use metal-reinforced line, wire, chain or rope. These can break off and become dangerous projectiles.
- Do not replace the cutting head with rigid or metal blades. Doing so could result in serious injury.

- Be aware of risk of injury to the head, hands and feet.
- Carefully inspect the area before starting the unit. Remove rocks, broken glass, nails, wire, string and other objects that may be thrown or become entangled with the unit.
- Clear the area of children, bystanders and pets; keep them outside a 50-foot (15 m) radius, at a minimum. Even then, they are still at risk from thrown objects. Encourage bystanders to wear eye protection. If you are approached, stop the unit immediately.
- Squeeze the throttle control and check that it returns automatically to the idle position. Make all adjustments or repairs before using the unit.
- Do not change the engine governor settings or overspeed the engine.
- This unit is intended for occasional, household use only.

SAFETY WARNINGS FOR GAS UNITS



WARNING: Gasoline is highly flammable and its vapors can explode if ignited. Take the following precautions:

- Store fuel only in containers specifically designed and approved for the storage of such materials.
- Always stop the engine and allow it to cool before filling the tank. Never remove the fuel tank cap or add fuel when the engine is hot. Always loosen the fuel tank cap slowly to relieve any pressure in the tank before fueling.
- Always mix and add fuel in a clean, well-ventilated outdoor area where there are no sparks or flames. DO NOT smoke.
- Never operate the unit without the fuel cap securely in place.
- Avoid creating a source of ignition for spilled fuel. Wipe up any spilled fuel from the unit immediately, before starting the unit. Move the unit at least 30 ft. (9.1 m) from the fueling source and site before starting the engine. DO NOT smoke.
- Never start or run the unit inside a closed room or building. Breathing exhaust fumes can kill. Operate this unit only in a well ventilated outdoor area.

WHILE OPERATING

- Wear safety glasses or goggles that meet current ANSI / ISEA Z87.1 standards and are marked as such. Wear ear/hearing protection when operating this unit. Wear a face mask or dust mask if the operation is dusty.
- Wear heavy long pants, boots, gloves and a long sleeve shirt. Do not wear loose clothing, jewelry, short pants, sandals or go barefoot. Secure hair above shoulder level.
- The cutting head shield must always be in place while operating the unit. Do not operate the unit without both trimming lines extended and the proper line installed. Do not extend the trimming line beyond the length of the shield.
- The cutting head should remain stationary when the engine idles. If it does not, refer to *Adjusting the Idle Speed*.
- Adjust the handle to provide the best grip, if applicable.
- Make sure the cutting head is not in contact with anything before starting the unit.
- Use the unit only in daylight or good artificial light.
- Avoid accidental starting. Be in the starting position whenever pulling the starter rope. The operator and unit must be in a stable position while starting. Refer to *Starting and Stopping*.
- Use the right tool. Only use this tool for its intended purpose.
- Always hold the unit with both hands when operating. Keep a firm grip on both handles or grips.
- Do not overreach. Always keep proper footing and balance. Take extra care when working on stairs, steep slopes or inclines. To avoid serious injury, do not operate the unit while on a ladder or a roof.
- Keep hands, face, and feet away from all moving parts. Do not touch or try to stop moving parts.
- Do not touch the engine, gear housing or muffler. These parts get extremely hot from operation, even after the unit is turned off.
- Do not operate the unit faster than the speed needed to do the job. Do not run the unit at high speed when not in use.
- Do not force the unit. It will do a better, safer job when used at the intended rate.
- Always stop the unit when operation is delayed or when walking from one location to another.

- Before setting the unit down, always make sure the engine is off and all moving parts have stopped.
- If you strike or become entangled with a foreign object, stop the unit immediately and check for damage. Do not operate the unit before repairing damage. Do not operate the unit with loose or damaged parts.
- Turn the engine off and disconnect the spark plug for maintenance or repair.
- Use only original equipment manufacturer (OEM) replacement parts and accessories for this unit. These are available from your authorized service dealer. Use of any other parts or accessories could lead to serious injury to the user, or damage to the unit, and void the warranty.
- Keep the unit clean. Carefully remove vegetation and other debris that could block moving parts.
- To reduce fire hazard, replace a faulty muffler and spark arrestor. Keep the engine and muffler free from grass, leaves, excessive grease or carbon build up.
- If the unit starts to vibrate abnormally, stop the unit immediately. Inspect the unit for the cause of the vibration. Vibration is generally an indicator of trouble.









OTHER SAFETY WARNINGS









- Maintain the unit with care.
- All service, other than the maintenance procedures described in this manual, should be performed by an authorized service dealer.
- Never remove, modify or make inoperative any safety device furnished with the unit.
- Before inspecting, servicing, cleaning, storing, transporting or replacing any parts on the unit:
 1. Stop the unit.
 2. Make sure all moving parts have stopped.
 3. Allow the unit to cool.
 4. Disconnect the spark plug wire.
- Secure the unit while transporting.
- Never store the unit with fuel in the tank, inside a building where fumes may reach an open flame (pilot lights, etc.) or sparks (switches, electrical motors, etc.).
- Store the unit in a dry place, secured or at a height to prevent unauthorized use or damage. Keep the unit out of the reach of children.
- Never douse or squirt the unit with water or any other liquid. Keep handles dry and clean (free from debris, oil and grease).
- Clean the unit after each use. Refer to *Cleaning and Storage*. Do not use solvents or strong detergents.
- Keep these instructions. Refer to them often and use them to instruct other users. If you loan this unit to others, also loan them these instructions.

SAVE THESE INSTRUCTIONS

• SAFETY & INTERNATIONAL SYMBOLS •

This operator's manual describes safety and international symbols and pictographs that may appear on this product. Read the operator's manual for complete safety, assembly, operating and maintenance and repair information.

SYMBOL	MEANING
	SAFETY ALERT SYMBOL Indicates danger, warning or caution. May be used in conjunction with other symbols or pictographs.
	READ OPERATOR'S MANUAL WARNING: Read the operator's manual(s) and follow all warnings and safety instructions. Failure to do so can result in serious injury to the operator and/or bystanders.
	WEAR EYE AND HEARING PROTECTION WARNING: Thrown objects and loud noise can cause severe eye injury and hearing loss. Wear eye protection meeting current ANSI / ISEA Z87.1 standards and ear protection when operating this unit. Use a full face shield when needed.
	WEAR FOOT PROTECTION Always wear heavy-duty, non-slip footwear when operating this unit.
	WEAR HAND PROTECTION Always wear heavy-duty, non-slip gloves when handling this unit.
	HANDLE POSITION Make sure the handle is positioned beyond the end of the safety label.
	UNLEADED FUEL Always use clean, fresh unleaded fuel.
	OIL Refer to operator's manual for the proper type of oil.
	DO NOT USE E85 FUEL IN THIS UNIT WARNING: It has been proven that fuel containing greater than 10% ethanol will likely damage this engine and void the warranty.

SYMBOL	MEANING
	ON/OFF STOP CONTROL ON / START / RUN
	ON/OFF STOP CONTROL OFF or STOP
	PRIMER BULB Push primer bulb, fully and slowly, 10 times.
	THROWN OBJECTS CAN CAUSE SEVERE INJURY WARNING: Small objects can be propelled at high speed, causing injury.
	KEEP BYSTANDERS AWAY WARNING: Keep all bystanders, especially children and pets, at least 50 feet (15 m) from the operating area.
	HOT SURFACE WARNING: Do not touch a hot muffler or cylinder. You may get burned. These parts get extremely hot from operation. When turned off, they remain hot for a short time.
	SHARP BLADE WARNING: There is a sharp blade on the cutting head shield. To prevent serious injury, do not touch the line cutting blade.
	DO NOT USE METAL BLADES WARNING: To prevent serious injury, do not replace the cutting head with rigid or metal blades.

KNOW YOUR UNIT

APPLICATIONS

As a trimmer /brush cutter:

- Cutting grass and light weeds.
- Edging
- Decorative trimming around trees, fences, etc.

Other optional attachments may be used with this unit.

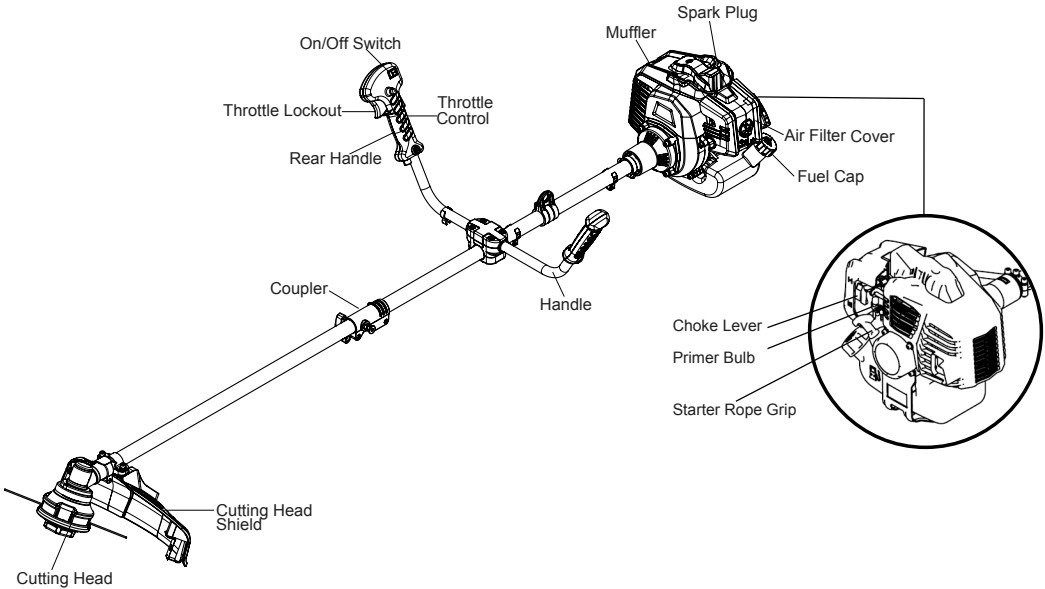

SPECIFICATIONS*

Model name	WB52BCI
Engine type	Air-Cooled, 2-Cycle
Engine displacement	51.7cc
Rated motor power	1.3kw
Lubrication	Fuel/Oil Mixture
Fuel/Oil ratio	50:1
Volumes of fuel tank	38.72 oz. (1100ml)
Trimmer mechanism	Bump Head
Cutting path diameter	18in (450mm)
Trimming line (with cutting attachment, no-load)	0.095 in. (2.4mm) / 0.103 in. (2.6mm)
Max. engine speed (with cutting attachment, no-load)	9600/min

* All specifications are based on the latest product information available at the time of printing. We reserve the right to make changes at any time without notice.

ASSEMBLY

When assembling this machine, please follow the instructions for assembly steps.

1. Mounting the rod:



2.1 Assemble the handle on the machine.

Assemble the bike type handle on the machine:

First release the inner hex screws,
second take right and left handle on the centre of handle holder,
last assemble the handle holder and tighten the inner screws
enough.

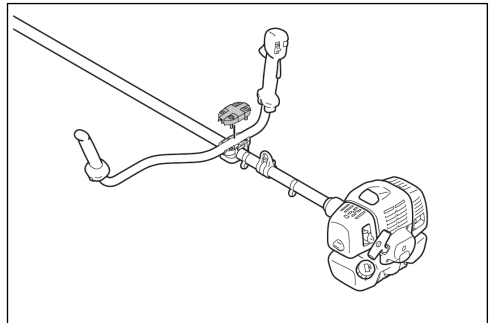

3. Fitting the guard for straight shaft grass deflector

- Fix the transmission with hex key and wrench enclosed as standard accessories for tightening the nuts with the safe guard.
- The guard is fixed to the angle transmission by two screws

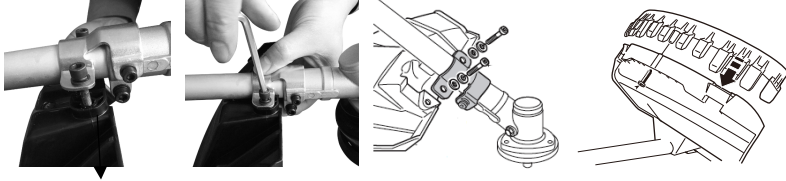

Warning! Use only original manufacturer's replacement parts, accessories and attachments. Failure to do so can cause poor performance, possible injury and may void your warranty. Never use the machine without the guard assembled!

4. Assembly and disassembly of the cutting head

- a) **Release the nut.** Line up the two holes of flange and shield, use one screw driver to hold the flange as below and turn the socket wrench clockwise, the nut will be released.



- b) **Fit the Nylon cutting head.** Remove another shield after release the nut. Still hold the flange, take the Nylon cutting head on the shaft and rotate counter-clockwise, the Nylon cutting head is fitted.

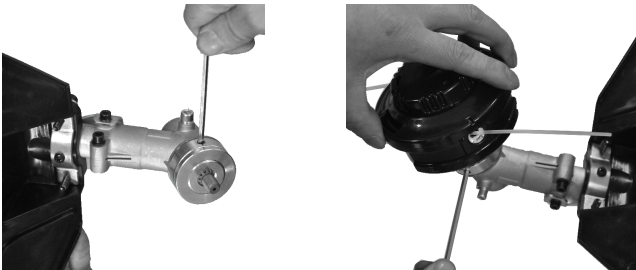

c) Release the Nylon cutting head. Use screw driver to hold flange and then rotate the Nylon cutting head clockwise, it will be replaced.

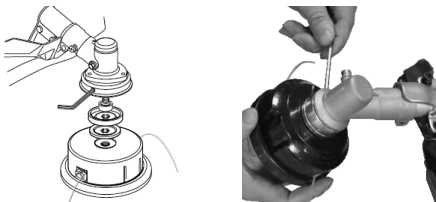

d) Fit the blade. Take the outer flange off after release the nut, then put the blade, outer flange, shield and nut according to priority as below picture. Note the blade rotation direction needs be same as below picture. Use screw driver to hold flange and tighten nut counter-clockwise, ensure the nut is tightened enough.

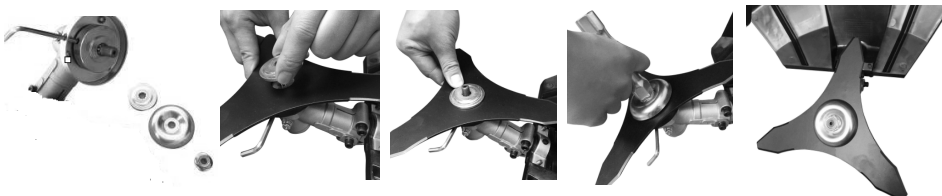

e) Release blade. Use screw driver to hold flange and release nut, the blade can be took off.

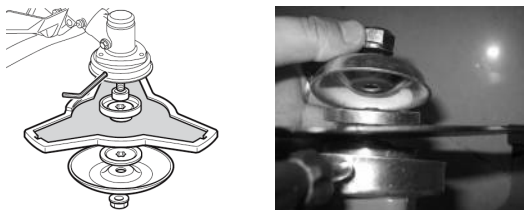

Warning!

Please make sure the cutting head has been assembled correctly before use!

5. Fit the belt. According to picture showing, fit the belt well.



OPERATION

When operating this machine, please follow the instructions for operations steps.

1. Filling with fuel



Danger of injury!

Fuel is explosive!

- Turn off and cool the motor down before filling the tank with fuel.
- You must observe all safety instructions relating to handling fuel.



Risk of device damage!

The device is supplied without motor or gearbox oil.

Before operating, you must fill it with fuel.

Never use oil for 4-cycle engine use or water-cooled 2-cycle engine. It can cause spark plug fouling, exhaust port blocking or piston ring sticking.

Mixed fuels, which have been left unused for a period of one month or more may clog the carburetor or result in the engine failing to operate properly. Put remaining fuel into an airtight container and keep it in the dark and cool room.

Mix a regular grade gasoline (leaded or unleaded, alcohol-free) and a quality-proven motor oil for air-cooled 2 cycle engines.

RECOMMENDED MIXING RATIO

GASOLINE 50: OIL 1

WARNING! Take care of the emission of exhaust gases. Always shut off engine before fueling. Never add fuel to a machine with a running or hot engine. Take care of fire!

WARNING! Never smoke whilst refueling and avoid inhaling the petrol fumes.

WARNING! Carefully open the tank top as pressure could have formed inside.

Before refuelling:

- Shake the fuel mixture container well.
- Place the machine on a flat stable surface, with the fuel tank cap facing upwards.
- Clean the fuel tank cap and the surrounding area to avoid any dirt from entering the tank during refilling.
- Carefully open the fuel tank cap to allow the pressure inside to decrease gradually. Use a funnel to refill and avoid filling the tank to the brim.
- Unscrew the tank cap and remove it.
- Pour in the fuel carefully, avoid spilling.
- Screw the tank cap on firmly by hand.



Draining fuel

- Hold a collection container beneath the fuel drain bolt.
- Unscrew the tank cap and remove it.

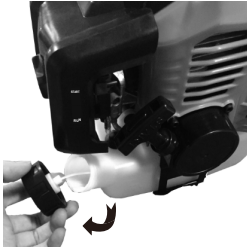

- Allow the fuel to run out completely.
- Screw the tank cap on firmly by hand.

WARNING! Always close the fuel tank cap firmly.

WARNING! Immediately clean all traces of fuel which may have dripped on the machine or the ground and do not start the engine until the petrol fumes have dissipated.

Start on the unit

Do not start the unit until it has been completely assembled. Before switching on the unit, always check the oil.

Check before use!



Danger of injury!

Do not operate the device unless you did not find any faults. If a part has become defective, make sure to replace it before you use the device again.

Check the safe condition of the device:

- Check the device for leaks.
- Check the device for visual defects.
- Check that all parts of the device have been securely fitted.
- Check that all safety devices are in proper condition.



Danger of injury!

Before starting work, always check the ground and remove all objects which could be thrown by the device.

Once the machine has been set up properly, start the engine as follow:

1. Press the fuel pump 10 times.



2. Put the choke lever on the (START) position.

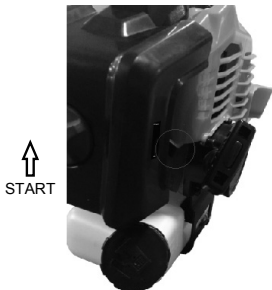

3. Pull the recoil starter handle 3-5 times to start the engine. Hold the machine firmly on the ground with one hand on the power unit, in order not to lose control of the machine during startup as following picture.



4. Pull the starter grip slowly for 10 - 15 cm until you feel some resistance, then tug it a few times until you hear the engine turn over. Then adjust the choke lever to (RUN) position.

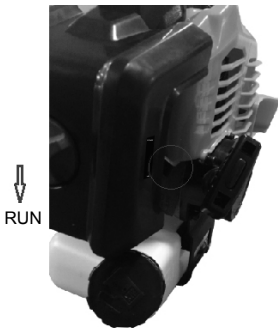

5. Pull the starter grip again until the engine starts as normal.



6. When the engine is running and idling, the throttle lever on handle is as below picture. First press the lock off lever and then switch the throttle lever on, the machine will be working.

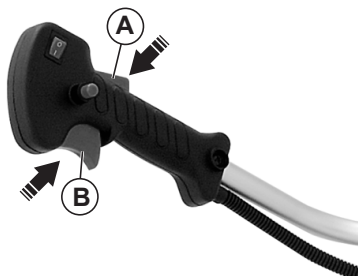

7. Adjusting line length when working: This machine is fitted with a “Tap & Go” head. To release more line, tap the cutting line head against the round with engine at top speed: the line will be released automatically and the knife cut off the excess length.

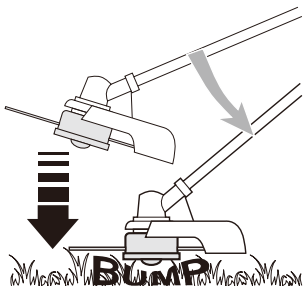

8. If meet any problem occurs, press the engine switch, the machine will stop running. If need stop cutting head working, release the throttle lever.



9. If any problem occurs, pull the pin of safety belt, then release the brush cutter immediately.
10. If the machine is hot, the throttle level can be adjusted to ON position directly when restart machine.
11. **WARNING!** Do not use the machine for sweeping, tilting the cutting line head. The power of engine could throw objects and small stones 15 metres or more, causing damage or injuries to people.

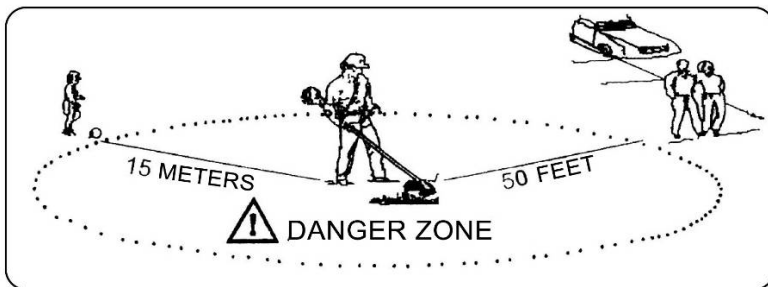

Note:

1. Do not start the motor in tall grass.
2. While mowing, lay the connection cable safely on footpaths and on areas which have already been mown.
3. When the engine has been switched off, the cutter continues running for several seconds therefore do not get close to the cutting head of the brush cutter until the cutter has come to a standstill!

When the engine has been switched off, the cutter continues running for several seconds therefore do not close to cutting head of grass trimmer until the cutter has come to a standstill!

ROUTINE MAINTENANCE

Correct maintenance is essential to maintain the original efficiency and safety of the machine over time.

Before performing any maintenance or cleaning work, always turn off the engine.

1. Do not spray the unit with water. Ingress of water may damage the engine and electrical connection.
2. Clean the unit with a cloth, hand brush, etc.

WARNING! During maintenance operations:

- Remove the spark plug cap.
- Wait until the engine is sufficiently cold.
- Never dispose of oils, fuel or other polluting materials in unauthorized places.

Maintenance schedule			
	12 hours of use	24 hours of	36 hours of
Air filter	clean	clean	replace
Spark plug	check	clean	replace

Expert inspection is required:

- a) If the grass trimmer strikes an object.
- b) If the motor stops suddenly
- c) If the nylon cutter is damaged
- d) If the gears are damaged.

Replacing and recleaning the nylon spool at the end of the trimming season. Always re-cleaned the nylon spool or, if required, replace the nylon spool with a new one. Always have the nylon spool re-cleaned or replaced by a customer service centre.

STORAGE

At the end of each working session, carefully clean the machine of dust and debris, and make sure that there are no damaged parts, replacing any faulty parts. The machine must be stored in a dry place away from the elements and with the cover correctly fitted.

CLEANING THE ENGINE AND THE SILENCER

To reduce fire risks, periodically clean the cylinder fins with compressed air and clear the silencer area to get rid of sawdust, branches, leaves or other debris.

STARTING UNIT

To avoid overheating and damage to the engine, always keep the cooling air vents clean and free of sawdust and debris. If you notice signs of wear on the starter cable, contact your Dealer for a replacement.

NUTS AND SCREWS

Periodically check that all the nuts and screws are securely tightened and the handgrips are tightly fastened.

Change and clean the spark plug

- Periodically remove and clean the spark plug using a metal brush to get rid of any deposits.
- Check and reset the correct distance between the electrodes.
- Replace the spark plug and fasten it firmly using the supplied wrench.
- The spark plug must be replaced with one with the same characteristics whenever the electrodes have burnt or the insulation has worn, and in any case every 100 working hours.

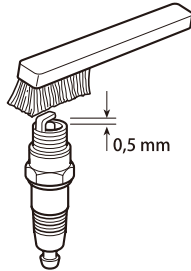

Clean the air filter

IMPORTANT Cleaning the air filter is essential to guarantee the efficiency and duration of the machine. Do not work with a damaged filter or without a filter, as this could permanently damage the engine. It must be cleaned after every 12 working hours.

Clean the filter as follows:

- Loosen the knob, remove the cover and the filter element
- Wash the filter element with soap and water. Do not use petrol or other solvents.
- Leave the filter to dry in the open air.
- Fit the filter element and the cover back on, tightening the knob again



Warning!

Never run the engine without the air filter element installed.

Head line replacement

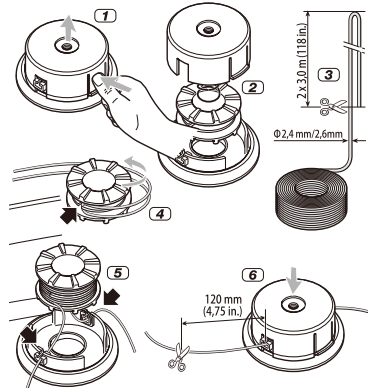

SHARPENING THE LINE CUTTING KNIFE

- Remove the line cutting knife (1) from the guard (2) by unscrewing the screws (3).
- Fix the line cutting knife in a vice and sharpen it using a flat file, being careful to retain the original cutting angle.
- Refit the knife on the guard.

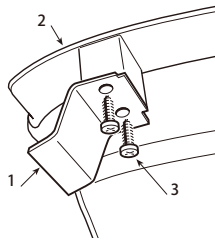

CLEANING AND STORAGE

CLEANING



WARNING: To avoid serious personal injury, always stop the engine and allow it to cool before cleaning or maintaining the unit.

Use a small brush to clean the outside of the unit. Do not use strong detergents. Household cleaners that contain aromatic oils such as pine and lemon, and solvents such as kerosene, can damage plastic. Wipe off any moisture with a soft cloth.

STORAGE

- Never store a fueled unit where fumes may reach an open flame or spark.
- Allow the engine to cool before storing.
- Lock up the unit to prevent unauthorized use or damage.
- Store the unit in a dry, well-ventilated area.
- Store the unit out of the reach of children.
- To suspend the attachment from a hook, install the hanger cap onto the attachment. Make sure the release button is securely locked into one of the holes on the hanger cap.

Short-term Storage (1-2 weeks)

1. Store the unit in a horizontal position. If this is not possible, store the unit vertically with the engine at the top.

Long-term Storage

1. Remove the fuel cap, tip the unit and drain the fuel into an approved container. Reinstall the fuel cap.
2. Start the engine and allow it to run until it stalls. This ensures that all fuel has been drained from the carburetor.
3. Allow the engine to cool. Remove the spark plug and put 5 drops of any high-quality motor oil or 2-cycle oil into the cylinder. Pull the starter rope slowly to distribute the oil. Reinstall the spark plug.
4. Thoroughly clean the unit and inspect it for any loose or damaged parts. Repair or replace damaged parts and tighten loose screws, nuts or bolts.

Preparing the Unit for Use after Long-term Storage

1. Remove the spark plug. Tip the unit and drain all of the oil from the cylinder into an approved container. Reinstall the spark plug.
- NOTE:** Do not use fuel that has been stored for more than 30 days. Dispose of old fuel and oil according to federal, state and local regulations.

TROUBLESHOOTING

PROBLEM	SOLUTION
THE ENGINE WILL NOT START	
The fuel tank is empty	Fill the fuel tank with properly-mixed fuel
The primer bulb was not pressed enough	Press the primer bulb 10 times or until fuel is visible
The engine is flooded	Squeeze the throttle control and pull the starter rope until the engine starts
The fuel is old (over 30 days) and/or improperly mixed	Drain the fuel tank and add fresh, properly-mixed fuel
The spark plug is fouled	Replace the spark plug
The choke lever was not flipped	Refer to <i>Starting Instructions</i> in the <i>Starting and Stopping</i> section
THE ENGINE WILL NOT IDLE	
The air filter is dirty	Clean or replace the air filter
The fuel is old (over 30 days) and/or improperly mixed	Drain the fuel tank and add fresh, properly-mixed fuel
The idle speed is incorrect	Adjust the idle speed
THE ENGINE WILL NOT ACCELERATE	
The fuel is old (over 30 days) and/or improperly mixed	Drain the fuel tank and add fresh, properly-mixed fuel
The cutting head is bound with grass	Stop the engine and clean the cutting head
The air filter is dirty	Clean or replace the air filter
THE ENGINE LACKS POWER OR STALLS	
The fuel is old (over 30 days) and/or improperly mixed	Drain the fuel tank and add fresh, properly-mixed fuel
The air filter is dirty	Clean or replace the air filter
The spark plug is fouled	Replace the spark plug
THE CUTTING HEAD WILL NOT ADVANCE LINE	
The cutting head is bound with grass	Stop the engine and clean the cutting head
The cutting head is out of line	Refill the cutting head with new line
The inner reel is bound up	Rewind the line
The cutting head is dirty	Clean the inner reel and outer spool
The line is welded	Open the cutting head and remove the welded section
The line is twisted	Rewind the line
Not enough line is extended	Stop the unit, push the bump knob and pull the line until 4 inches (102 mm) is outside of the cutting head
THE CUTTING LINE ADVANCES UNCONTROLLABLY	
There is oil, cleaner or lubricant in the cutting head	Clean and thoroughly dry the cutting head

If further assistance is required, contact an authorized service dealer.

MANUFACTURER'S LIMITED WARRANTY

The limited warranty set forth below is given by Badger with respect to new merchandise purchased and used in the United States, its possessions and territories .

Badger warrants this product against defects in material and workmanship for a period of three (3) years commencing on the date of original purchase and will, at its option, repair or replace, free of charge, any part found to be defective in material or workmanship. This limited warranty shall only apply if this product has been operated and maintained in accordance with the Operator's Manual furnished with the product, and has not been subject to misuse, abuse, commercial use, neglect, accident, improper maintenance, alteration, vandalism, theft, fire, water or damage because of other peril or natural disaster. Damage resulting from the installation or use of any accessory or attachment not approved by Badger for use with the product(s) covered by this manual will void your warranty as to any resulting damage. This warranty is limited to ninety (90) days from the date of original retail purchase for any Badger product that is used for rental or commercial purposes, or any other income-producing purpose.

HOW TO OBTAIN SERVICE: Warranty service is available, WITH PROOF OF PURCHASE THROUGH YOUR LOCAL AUTHORIZED SERVICE DEALER. To locate the dealer in your area, call **1-844-786-7335**. No product returned directly to the factory will be accepted unless prior written permission has been extended by the Customer Service Department of Badger.

This limited warranty does not provide coverage in the following cases:

- A. Tune-ups - Spark Plugs, Carburetor Adjustments, Filters
- B. Wear items - Bump Knobs, Outer Spools, Cutting Line, Inner Reels, Starter Pulley, Starter Ropes, Drive Belts, Saw Chains, Guide Bars, Cultivator Tines, Blades.
- C. Badger does not extend any warranty for products sold or exported outside of the United States of America, its possessions and territories, except those sold through Badger's authorized channels of export distribution. Badger reserves the right to change or improve the design of any Badger Product without assuming any obligation to modify any product previously manufactured.

No implied warranty, including any implied warranty of merchantability or fitness for a particular purpose, applies after the applicable period of express written warranty above as to the parts as identified. No other express warranty or guaranty, whether written or oral, except as mentioned above, given by any person or entity, including a dealer or retailer, with respect to any product shall bind Badger. During the period of the Warranty, the exclusive remedy is repair or replacement of the product as set forth above. (Some states do not allow limitations on how long an implied warranty lasts, so the above limitation may not apply to you.)

The provisions as set forth in this Warranty provide the sole and exclusive remedy arising from the sales. Badger shall not be liable for incidental or consequential loss or damages including, without limitation, expenses incurred for substitute or replacement lawn care services, for transportation or for related expenses, or for rental expenses to temporarily replace a warranted product. (Some states do not allow limitations on how long an implied warranty lasts, so the above limitation may not apply to you.)

In no event shall recovery of any kind be greater than the amount of the purchase price of the product sold. Alteration of the safety features of the product shall void this Warranty. You assume the risk and liability for loss, damage, or injury to you and your property and/or to others and their property arising out of the use or misuse or inability to use the product.

This limited warranty shall not extend to anyone other than the original purchaser, original lessee or the person for whom it was purchased as a gift.

How State Law Relates to this Warranty: This warranty gives you specific legal rights, and you may also have other rights which vary from state to state.

To locate your nearest service dealer, dial **1-844-786-7335** in the United States.

BADGER
SBCC