

Please read and save these instructions. Read through this owner's manual carefully before using product. Protect yourself and others by observing all safety information, warnings, and cautions. Failure to comply with instructions could result in personal injury and/or damage to product or property. Please retain instructions for future reference.



## HARMONIC BALANCER PULLER KIT

### FOR CUSTOMER SERVICE

Technical Question?

**CALL 1-866-458-2472**  
**customerservice@oem-tools.com**

### UNPACKING

After unpacking unit, inspect carefully for any damage that may have occurred during transit. Check for loose, missing, or damaged parts. If any damage is observed, a shipping damage claim must be filed with carrier. Do not use the OEMTOOLS™ Harmonic Balancer Puller Kit if broken, bent, cracked or damaged parts (including labels) are noted. Any Harmonic Balancer Puller Kit that appears damaged in any way, operates abnormally or is missing parts should be removed from service immediately. If you suspect that the Harmonic Balancer Puller Kit was subjected to shock load (a load that was dropped suddenly, unexpectedly, etc.), immediately discontinue use until it has been checked by a factory authorized service center.



### ⚠ WARNING

The following safety information is provided as a guideline to help you operate your Harmonic Balancer Puller Kit under the safest possible conditions. Any tool or piece of equipment can be potentially dangerous to use when safety or safe handling instructions are not known or not followed. The following safety instructions are to provide the user with the information necessary for safe use and operation. Please read and retain these instructions for the continued safe use of your tool. Failure to follow instructions listed below may result in serious injury. In addition, make certain that anyone that uses the equipment understands and follows these safety instructions as well.

### Explanation of Safety Signal Words

**⚠ WARNING:** Indicates a potentially hazardous situation which, if not avoided, could result in death or serious injury.

**⚠ CAUTION:** Indicates a potentially hazardous situation which, if not avoided, may result in minor or moderate injury.

**CAUTION:** Used without the safety alert symbol indicates a potentially hazardous situation which, if not avoided, may result in property damage.

**NOTES:** Provide clarity and helpful information.

Thank you very much for choosing an OEMTOOLS™ Product!

For future reference, please register your new tool at [www.oem-tools.com](http://www.oem-tools.com) and complete the owner's record below:

**Model:** \_\_\_\_\_ **Purchase Date:** \_\_\_\_\_

Save the receipt, warranty and these instructions. It is important that you read the entire manual to become familiar with this product before you begin using it. This product is designed for certain applications only. OEMTOOLS™ cannot be responsible for issues arising from modification. We strongly recommend this product is not modified and/or used for any application other than that for which it was designed. If you have any questions relative to a particular application, DO NOT use the product until you have first contacted customer service to determine if it can or should be performed on the product.

**⚠ WARNING:** This product can expose you to chemicals, including lead, which are known to the State of California to cause cancer and birth defects or other reproductive harm. For more information, go to [www.P65Warnings.ca.gov](http://www.P65Warnings.ca.gov).



## HARMONIC BALANCER PULLER KIT

### **! IMPORTANT INSTRUCTIONS AND SAFETY RULES**

1. Know your tool. Read this manual carefully. Learn the tool's applications and limitations, as well as potential hazards specific to it.
2. Keep work area clean and well lit. Cluttered or dark work areas invite accidents.
3. Keep children away. All children should be kept away from the work area. Never let a child handle a tool without strict adult supervision.
4. DO NOT operate this tool if under the influence of alcohol or drugs. Read warning labels on prescriptions to determine if your judgment or reflexes are impaired while taking drugs. If there is any doubt, DO NOT attempt to operate.
5. Use safety equipment. Eye protection should be worn at all times when operating this tool. Use ANSI approved safety glasses. Everyday eyeglasses are NOT safety glasses. Dust mask, non-skid safety shoes, hard hat or hearing protection should be used in appropriate conditions.
6. Wear proper apparel. Loose clothing, gloves, neck-ties, rings, bracelets or other jewelry may present a potential hazard when operating this tool. Keep all apparel clear of the tool.
7. DO NOT overreach. Keep proper footing and balance at all times when operating this tool.
8. Check for damage. Check your tool regularly. If part of the tool is damaged, it should be carefully inspected to make sure it can perform its intended function correctly. If in doubt, the part should be repaired. Refer all servicing to a qualified technician. Consult your dealer for advice.
9. Keep away from flammables. DO NOT attempt to operate this tool near flammable materials or combustibles. Failure to comply may cause serious injury or death.
10. Store idle tools out of the reach of children and untrained persons. Tools may be dangerous in the hands of untrained users.
11. Maintain tools with care.
12. Keep tools dry and clean.
13. DO NOT use a damaged tool. Tag damaged tools "DO NOT USE" until repaired.
14. Use only accessories that are recommended by the manufacturer for your model. Accessories that may be suitable for one tool may become hazardous when used on another tool.
15. Tool service must be performed only by qualified repair personnel. Service or maintenance performed by unqualified personnel could result in a risk of injury.
16. When servicing a tool, use only identical replacement parts. Use of unauthorized parts or failure to follow maintenance instructions may create a risk of injury.
17. Maintain a safe working environment. Keep the work area well lit. Make sure there is adequate surrounding workspace. Keep the work area free of obstructions, grease, oil, trash, and other debris. DO NOT use this product in a damp or wet location.
18. Maintain labels and nameplates on this product. These carry important information. If unreadable or missing, contact customer service.
19. Before use, read and understand all warnings, safety precautions, and instructions as outlined in the vehicle manufacturer's service manual. It is beyond the scope of this manual to properly describe the correct procedure and test data for each vehicle.
20. Always perform vehicle service in a properly ventilated area. Never run an engine without proper ventilation for its exhaust. Stop work and take necessary steps to improve ventilation in the work area if you develop momentary eye, nose, or throat irritation as this indicates inadequate ventilation.

### **! WARNING**

Engine parts that are in motion or unexpected movement of a vehicle can injure or kill. When working near moving engine parts, wear snug fit clothing and keep hands and fingers away from moving parts. Keep hoses and tools clear of moving parts. Always stay clear of moving engine parts.

DO NOT smoke near engine fuel and battery components.

**NOTE:** The manufacturer declines any and all responsibility for damage to vehicles or components if said damage is the result of unskillful handling by the operator or of failure to observe the basic safety rules set forth in the instruction manual.

### **! WARNING**

Carefully read Rules for Safe Operation and Instructions.

### **IMPORTANT SAFETY INSTRUCTIONS**

The warnings, precautions, and instructions discussed in this manual cannot cover all possible conditions and situations that may occur. The operator must understand that common sense and caution are factors which cannot be built into this product but must be supplied by the operator.

### **! WARNING**

1. For safety purposes and to prevent damage to expensive components, it is advised that the user have an understanding of basic automotive repair and working knowledge of automotive systems.
2. We believe the information contained herein to be reliable. However, general technical information is given by us without charge and the user shall employ such information at their own discretion and risk. We assume no responsibility for results or damages incurred from the use of such information in whole or in part. Always refer to specific instructions and technical information supplied by vehicle manufacturer.
3. This equipment is intended only for professional use by personnel trained in performing the service functions for which it was designed.
4. This equipment is designed for servicing a variety of vehicles in a safe, convenient manner. However, differences in vehicle makes and models may make it impossible to use this equipment as it is intended. DO NOT attempt to force the use of this equipment on an application for which it is not designed to perform.



# HARMONIC BALANCER PULLER KIT

5. The procedures documented in this manual are to serve as guidelines for the use of this equipment.
6. In addition to these guidelines, always follow the manufacturer's recommended procedures when servicing each unique vehicle.

**DISPOSAL**

At the end of the useful life of the OEMTOOLS™ Harmonic Balancer Puller Kit, dispose of the components according to all state, federal, and local regulations.

**PURPOSE**

The Harmonic Balancer Puller Kit is designed to remove the harmonic balancer on many popular GM, Mitsubishi, and Chrysler engines with spoked pulleys (often without needing to remove the radiator).

**OPERATING INSTRUCTIONS WARNING**

Ensure that you read, understand and apply safety instructions before use.

1. Determine which Insert Rod will work best to remove crankshaft pulley.
2. Install the appropriate Insert Rod into the crankshaft.
3. Attach the 3-jaw puller to the damper and line up the forcing screw with the insert.
4. Tighten the forcing screw onto the puller to push against the insert.
5. Remove the crankshaft damper.

**MAINTENANCE WARNING**

Before each use, inspect the Harmonic Balancer Puller for damage. DO NOT use if bent, broken, cracked, leaking or otherwise damaged components are noted. Periodically, lightly oil all moving parts, including the pump piston and ram.

**PRODUCT COMPONENTS**

Figure	Description	Qty.
1	Puller Body	1
2	Puller Jaw	3
3	Jaw Retaining Pin	3
4	Wave Washer (Not Shown)	3
5	Pressure Screw	1
6	Insert Rod 4"	1
7	Insert Rod 5-13/32"	1
8	Insert Rod 6-1/2"	1
9	Insert Rod 7-13/32"	1

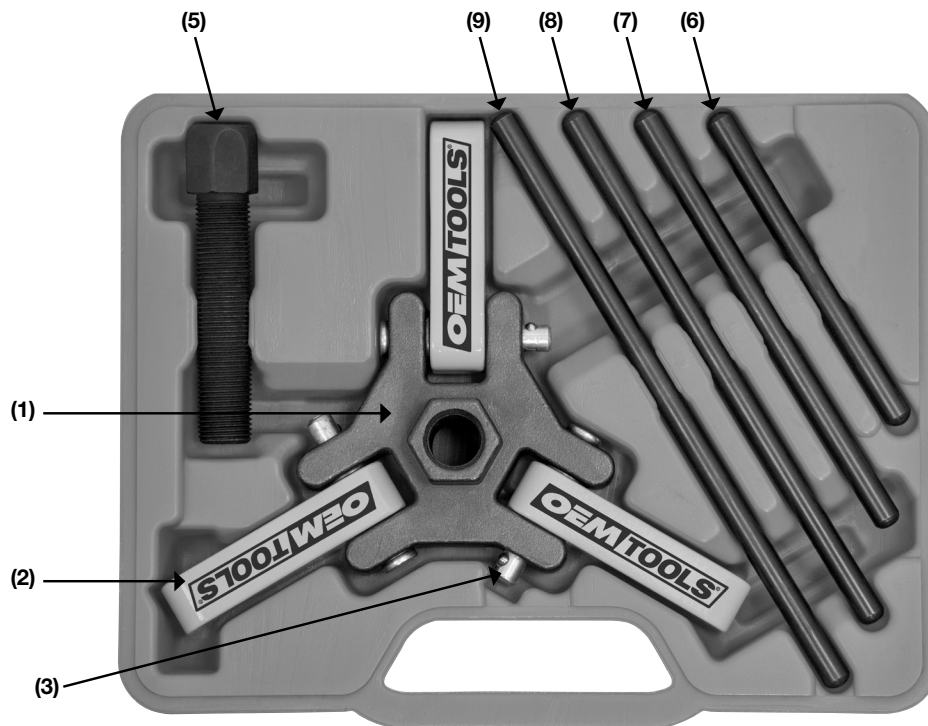



## HARMONIC BALANCER PULLER KIT

### OEMTOOLS™ 90 DAY WARRANTY

For up to 90 days from the original purchase of this OEMTOOLS™ product, if you find any defect in material or workmanship (through normal usage), return it to the place of purchase or to OEMTOOLS™ for repair or replacement at our discretion. In order to obtain this service, send your tool and proof of purchase (transportation pre-paid) to:

OEMTOOLS™ Q.A. Dept., 3580 E. Raines Road #3, Memphis, TN 38118.

We will not be responsible for lost or damaged goods during transportation; please insure your package. If our inspection verifies the defect, we will either repair or replace the product, or we may elect to refund the purchase price if we cannot readily and quickly provide you with a replacement. We will return repaired products at our expense, but if we determine there is no defect, or that the defect resulted from causes not within the scope of our warranty, then you must bear the cost of returning the product.

OEMTOOLS™ does not provide warranty for products labeled other than OEM® or OEMTOOLS™. OEMTOOLS™ will not provide any warranty for products subjected to abnormal use. Abnormal use includes (but is not limited to) abuse, accident, alteration, neglect, and unauthorized or unreasonable use or repairs. This warranty does not cover bits, blades, files, batteries, or calibration. We recommend that you maintain your tools and sharpen or replace blades, bits, files, and batteries as necessary. OEMTOOLS™ reserves the right to make any changes in construction or design at any time without any obligation in incorporating such changes to tools or equipment previously sold.

OEMTOOLS™ makes every effort to ensure that its products meet high quality and durability standards and warrants to the original purchaser that this product is free from defects in materials and workmanship for the period of 90 days from the date of purchase. This warranty does not apply to damage due directly or indirectly to misuse, abuse, negligence or accidents, repairs or alterations outside our facilities, criminal activity, improper installation, normal wear and tear, or to lack of maintenance.

We shall in no event be liable for death, injuries to persons or property, or for incidental, contingent, special or consequential damages arising from the use of our product. Some states do not allow the exclusion or limitation of incidental or consequential damages, so the above limitation of exclusion may not apply to you. THIS WARRANTY IS EXPRESSLY IN LIEU OF ALL OTHER WARRANTIES, EXPRESS OR IMPLIED, INCLUDING THE WARRANTIES OF MERCHANTABILITY AND FITNESS. This warranty gives you specific legal rights, and you may also have other rights, which vary from state to state.

Don't forget to register your new OEMTOOLS™ product at [www.oem-tools.com](http://www.oem-tools.com).

## CONTACT US

3580 E. Raines Road, Suite 3, Memphis, TN 38118  
Tel: 1-866-458-2472  
[www.oem-tools.com](http://www.oem-tools.com)