

USER'S MANUAL
WATER DISPENSER WITH ICE MAKER
EP23573

THIS INSTRUCTION BOOKLET CONTAINS **IMPORTANT** SAFETY INFORMATION. PLEASE READ AND KEEP FOR FUTURE REFERENCE.

Please give us a chance to make it right and do better!

Contact our friendly customer service department for help first.

Replacements for missing or damaged parts will be shipped ASAP!

Follow Costway

Visit us: www.costway.com



Contact Us!

Do NOT return this item.

Contact our friendly customer service department for help first.



Before You Start

- ⚠ Please read all instructions carefully.
- ⚠ Retain instructions for future reference.
- ⚠ Separate and count all parts and hardware.
- ⚠ Read through each step carefully and follow the proper order.
- ⚠ We recommend that, where possible, all items are assembled near to the area in which they will be placed in use, to avoid moving the product unnecessarily once assembled.
- ⚠ Always place the product on a flat, steady and stable surface.
- ⚠ Keep all small parts and packaging materials for this product away from babies and children as they potentially pose a serious choking hazard.

TABLE OF CONTENTS

<i>INTRODUCTIONS.....</i>	<i>4</i>
<i>IMPORTANT SAFETY INSTRUCTIONS.....</i>	<i>4</i>
<i>GETTING TO KNOW YOUR UNIT.....</i>	<i>6</i>
<i>Unit outline.....</i>	<i>6</i>
<i>Operation panel.....</i>	<i>7</i>
<i>Main function.....</i>	<i>7</i>
<i>START TO OPERATE THE UNIT.....</i>	<i>7</i>
<i>Unpack the unit.....</i>	<i>7</i>
<i>Clean your unit before first using.....</i>	<i>8</i>
<i>Prepare for use.....</i>	<i>8</i>
<i>Operate the unit.....</i>	<i>9</i>
<i>ELECTRICAL DIAGRAM.....</i>	<i>11</i>
<i>CLEAN YOUR UNIT DURING REGULAR USING.....</i>	<i>11</i>
<i>TROUBLE SHOOTING GUIDE.....</i>	<i>13</i>
<i>PRODUCT SPECIFICATION.....</i>	<i>15</i>

INTRODUCTIONS

Thank you for purchasing our ICE MARKER WITH WATER DISPENSER with multi-function. This unit is designed to improve your living and entertaining comfort. Not only you can enjoy ICE making function, also you can enjoy the cool and hot water drink. With its whisper quiet operation and attractive design, you will enjoy its convenience and comfort for years to come.

Please read these instructions carefully before operating this appliance. When using this appliance, always exercise basic safety precautions.

This easy-to-use manual will guide you to getting the best use of the unit.

Please complete the following information for future reference. You will need it to obtain warranty service.

Model No.: _____

Serial Number *: _____

Date of Purchase: _____

Place of Purchase: _____

IMPORTANT SAFETY INSTRUCTIONS

When using electrical appliances, basic safety precautions should be followed to reduce the risk of fire, electric shock, and injury to persons or property.

Read all instructions before using any appliance.

- Do not operate this, or any other appliance with a damaged cord.
Connect to properly polarized outlets only. No other appliance should be plugged into the same outlet. Be sure that the plug is fully inserted into the receptacle.
- Do not run the power cord over carpeting or other heat insulators. Do not cover the cord. Keep cord away from traffic areas, and do not submerge in water.
- We do not recommend the use of an extension cord, as it may overheat and become a risk of fire. If you must use an extension cord, use No.14 AWG minimum size and rated no less than 1875 watts.
- If the unit is brought in from outside in wintertime, give it a few hours to warm up to room temperature before plugging it in.
- Do not let hot water touch bare skin. Exercise caution and use reasonable supervision when appliance is used near children.
- Do not use your unit outdoors.
Locate the unit at a even or flat surface, to avoid a hazard due to instability of the appliance.

- And place the unit away from direct sunlight and make sure that there is at least 2 inches of space between the back of your unit and wall. Keep a minimum distance of 4 inches on each side of your unit free.
- Do not tip over the unit.
- Do not use other liquid to make the ice-cube or dispense the cold drink other than water.
- Always turn off the unit and unplug when there is no water left in the bottle or when you are changing the bottle. Turn it back on after a new bottle has been placed and the air is purged from water taps.
- Unplug the unit before cleaning or making any repairs or servicing.
- Do not clean the unit with flammable fluids. The fumes can create a fire hazard or explosion.
- Disconnect the mains plug from the supply the supply socket when not in use or you go to have the travel for the holiday, where supply connection is via mains plug.

WARNING: This appliance must be earthed.

IMPORTANT:

The wires in this mains lead are colored in accordance with the following code:

Green or Green with a strip yellow:	Grounding
White:	Neutral
Black:	Live

WARNING: fill with potable water only.

GETTING TO KNOW YOUR UNIT

Unit Outline

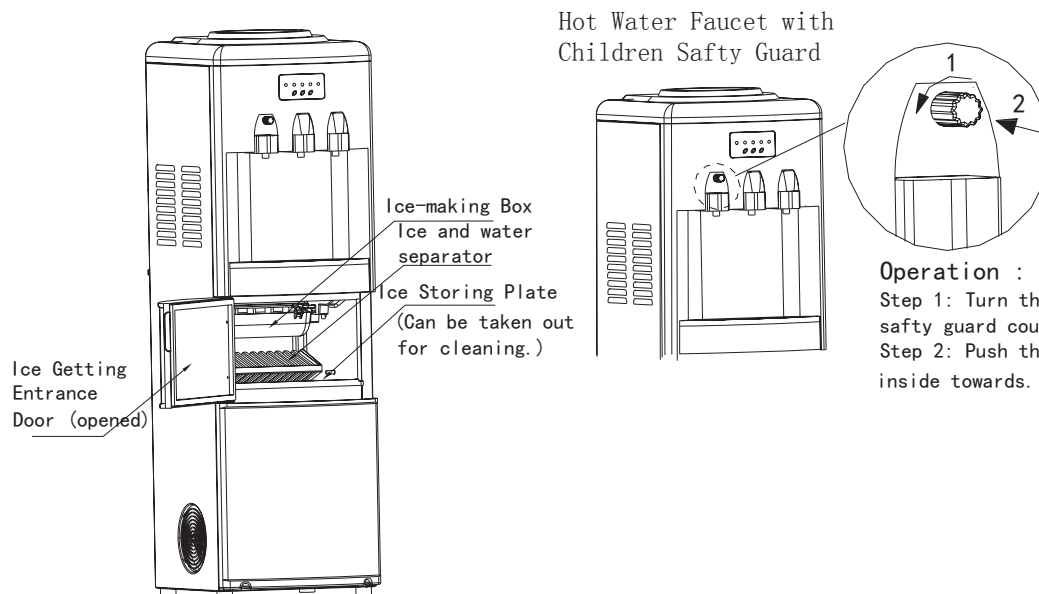
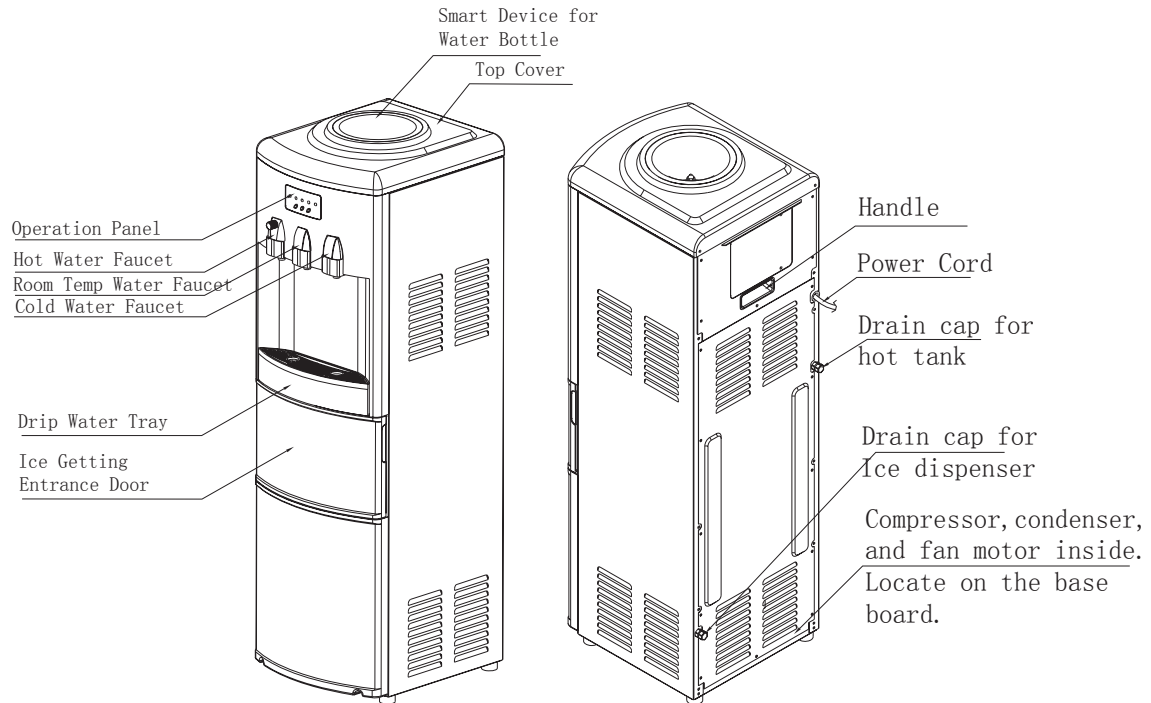

Operation :
Step 1: Turn the shaft of children safety guard counter-clockwisely.
Step 2: Push the turned shaft inside towards.

Operation panel

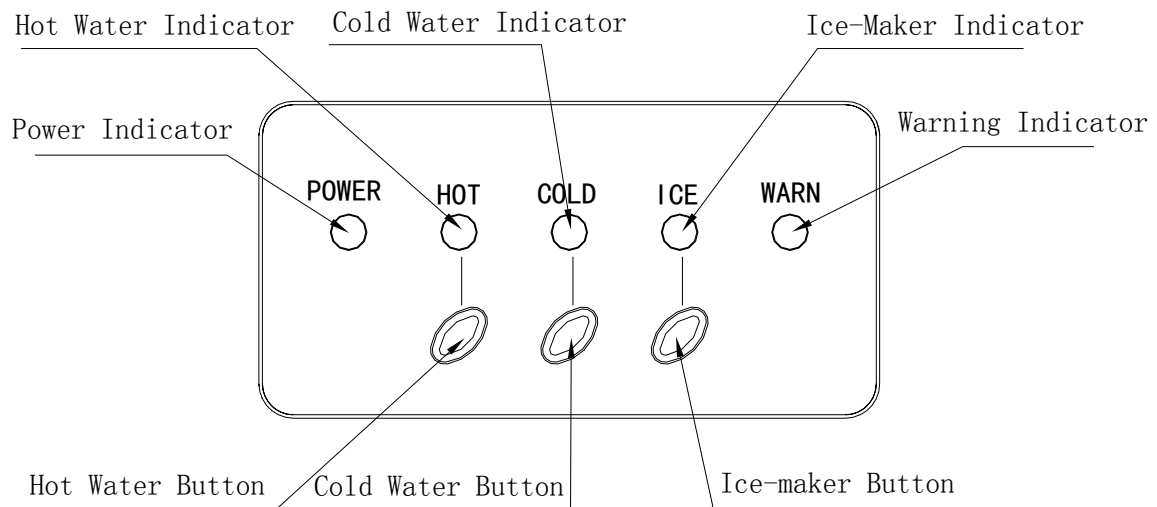

Main function

- Hot Water
- Cold Water only
- Ice-making only
- Cold water and ice-making at same time

START TO OPERATE YOUR UNIT

UNPACKING THE UNIT

- Removing the package, do not turn the unit upside down, or lay it on its side.
 - a. Remove the strapping
 - b. Open the cartoon box.
 - c. Remove the Styrofoam packing from the box.
 - d. Pull the unit straight up from the box.
 - e. Remove the plastic bag.

The refrigeration compressor has very sensitive mounts inside of its welded shell in order to provide quiet running. Improper handling may damage the compressor.

- Wipe it clean if necessary.
- Place the unit on the hard and flat ground. Pay attention to put it evenly and moderately. The location should be far away from direct sunlight and other source of heat.
- Please locate the unit at the place which have the good air circulation condition. And make sure that there are at least 2 inches between the back of unit and the wall.
Keep a minimum distance of 4 inches on each side of the unit
And far away from high temperature surrounding and prevent

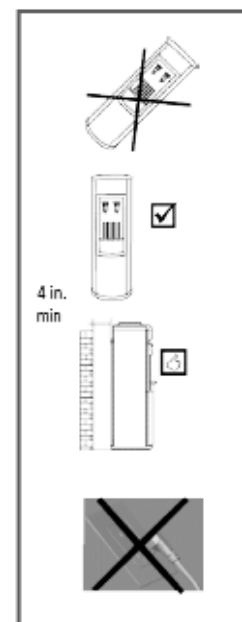

it from being exposed in the sunlight.

- The appliance must be positioned so that the plug is accessible.
 - Fasten the drain cap tightly at the back of the unit before start to run the unit. Because during the shipping process, it maybe has loosed. When you not fasten it again, it will cause the water leakage and make your floor wet.
 - Do not plug the power cord into the power socket yet! Read the instructions first.
-

This unit is for indoor use only.

Room temperature should not exceed 97°F/36°C

CLEAN YOUR UNIT BEFORE FIRST USING

Before using your unit, it is strongly recommended to clean it thoroughly.

1. Take out the accessory- Ice shovel from ice-making chamber.
2. The outside of the unit should be cleaned regularly with a mild detergent solution and warm water.
3. For the first time, hold the clean water bottle vertically and upside down (over the smart device) and place the water bottle into the smart device receptacle. After some minutes, the water will flow into all of the faucets, the cold water tank and hot water tank, till the water can flow out from the faucet. Then take down the water bottle, and open the drain cap for the hot tank, let all of the water flow out, then reinstall back the drain cap and tighten it.
4. Clean the ice-making chamber with diluted detergent, warm water and a soft cloth, then use the water to rinse the inside parts, and drain out the water by unplugging the drain cap of the ice dispenser on the down back of the unit. Then also reinstall back this drain cap of ice dispenser and tighten it.
5. When the machine is not in use for a long time, open both of the water drained cap to drain water completely from unit.

PREPARE FOR USE

Improper use of the grounded plug can result in the risk of electrical shock. If the power cord is damaged please call our customer service.

- 1). Make sure that the unit is not plugged into the main electrical outlet.
- 2). Before placing drinkable water bottle on the unit, be sure that the drain cap on the back is tightly fastened.
- 3). Hold the water bottle vertically and upside down (over the smart device) and place the water bottle into the smart device receptacle. Apply slightly pressure in order to pierce the bottle cap with the spigot. This unit accepts two, three or five gallons water bottle with pierceable sealed caps.
- 4). Open the water faucet to let the air out, until the water starts to flow out. When this happens, release the faucet taps.

5). Plug the unit into a grounded power outlet. **Do not plug in before the water can flow out from all of the water faucets.**

DANGER: This unit should be properly grounded for your safety. The power cord of this appliance is equipped with a three-prong plug which mates with standard three prong wall outlets to minimize the possibility of electric shock.

Plug your appliance into an exclusive, properly installed, grounded wall outlet. Do not under any circumstances, cut or remove the third (ground) prong from the power cord. Any questions concerning power and/or grounding should be directed toward a certified electrician.

This appliance requires a standard 110-120volt, 60Hz electrical outlet with three-prong ground.

6). If the unit is brought in from outside in winter time, give it a few hours to warm up to room temperature before plugging it in.

OPERATE THE UNIT

After plugging in the main power outlet, the POWER indicator on the control panel will be on. Then you can start to operate the hot water, cold water and ice-making function as your desired.

Hot Water Operation

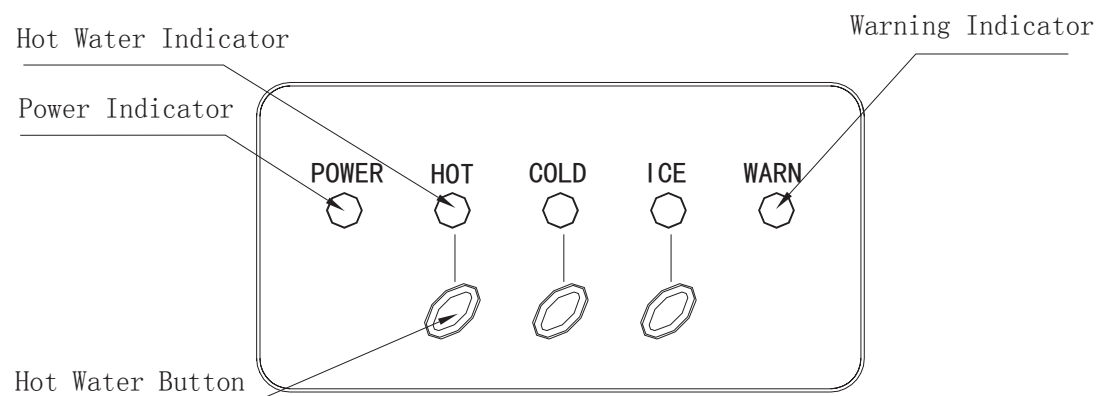

Press the Hot Water button, the green Hot Water indicator above the button will start to blinking, means that the heating element start to work.. When this green indicator change to illuminate always, means the hot water has reached the desired temperature and you can drink it. After some while or you drain out the hot water from the hot water faucet, the Hot Water indicator will return to start blinking, means that the heating element start heating again.

If there is no water in the hot tank in the first time using or after you drain out all of the water from the unit, after some minutes, the warning sound will last 10 times, and the Warning indicator will illuminate. If you place the water bottle again and need the hot water again, press the Hot Water button again, the heating element will start working again. And the Warning indicator will turn off at once.

If you do not want the hot water drink, please press the Hot Water button once more, it will save the electricity and reduce the electricity cost. (After this, the Hot Water indicator will be off.)

Cold Water Operation

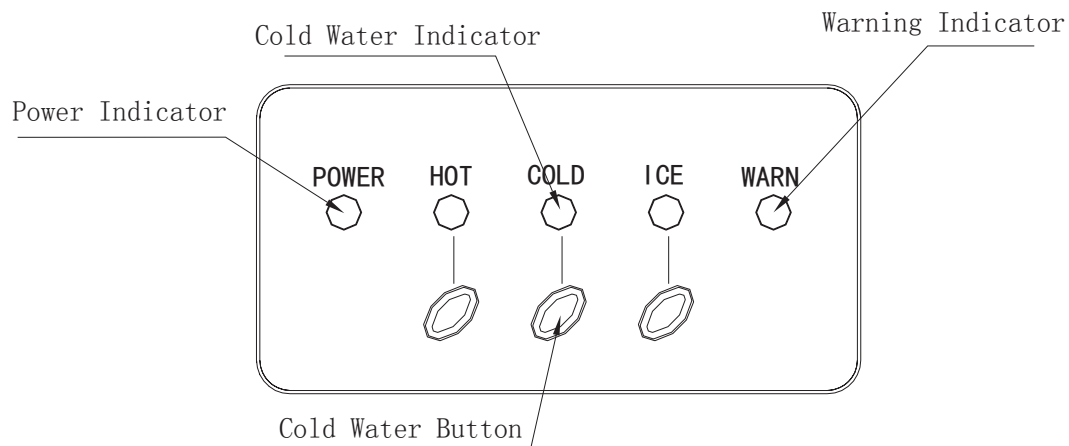

Press the Cold Water button to start making the cold water, after this, the Cold Water indicator will start to blink, means that the compressor has started running to cool the water. When the Cold Water indicator change from blinking to illuminating, means that the cold water has reached the desired temperature and you can have the cold drink. Also after some while or you drain out the cold water from the cold water faucet, the Cold Water indicator will return to blink, means during cooling process.

Cold Water function and Ice-making function can work together.

Ice-making Operation

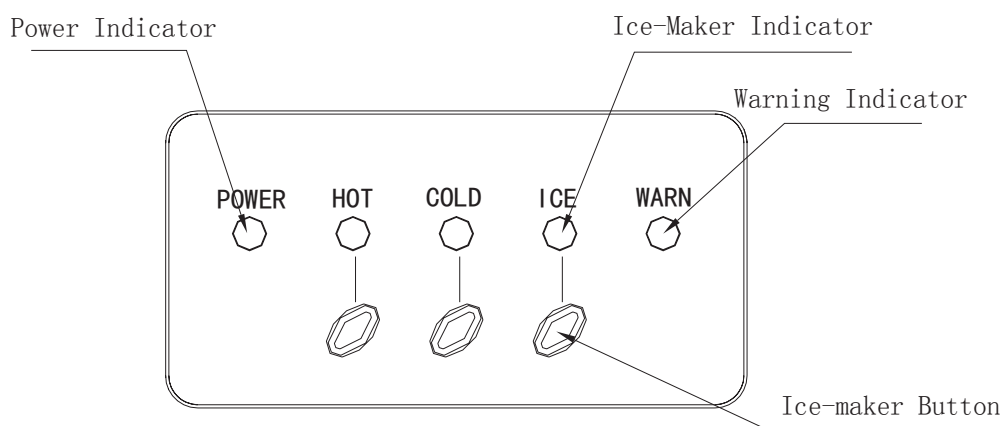

1. Press “Ice-maker” button on the operation panel to begin the ice making cycle. And the Ice-maker indicator will start to blink.
2. The ice making cycle lasts 7 to 15 minutes, depending on the ambient temperature.
3. While the ice-maker is on, the unit will verify water level periodically. If there is no enough water to make ice, the ice maker will stop automatically, and the Warning indicator will be on, means that the water level can not reach the requirement level for ice making.
4. The ice maker automatically stops working when the unit has detected full of the ice inside. And at same time the Ice-maker indicator will change from blinking to illuminating.
5. Ensure to keep a reasonable hygiene level in the water tank of the ice maker.

If unit isn't in use for a long time, take down the water bottle and drain out all water from both drain port at the back of the unit.

6. How to get the ice

Open the ice getting entrance door, use the ice scoop supplied as the accessory to get the ice from the unit.

Note: When you turn on the cold water operation and ice making operation at same time, you should wait some minutes to let the water temperature in the cold tank goes down to the set value first, then it will switch to ice-making operation. And if the cold water temperature goes up again or you drink the cold water from the cold water faucet, the unit will swift to Cold Water operation again after the present ice making cycle finished.

ELECTRIAL DIAGRAM

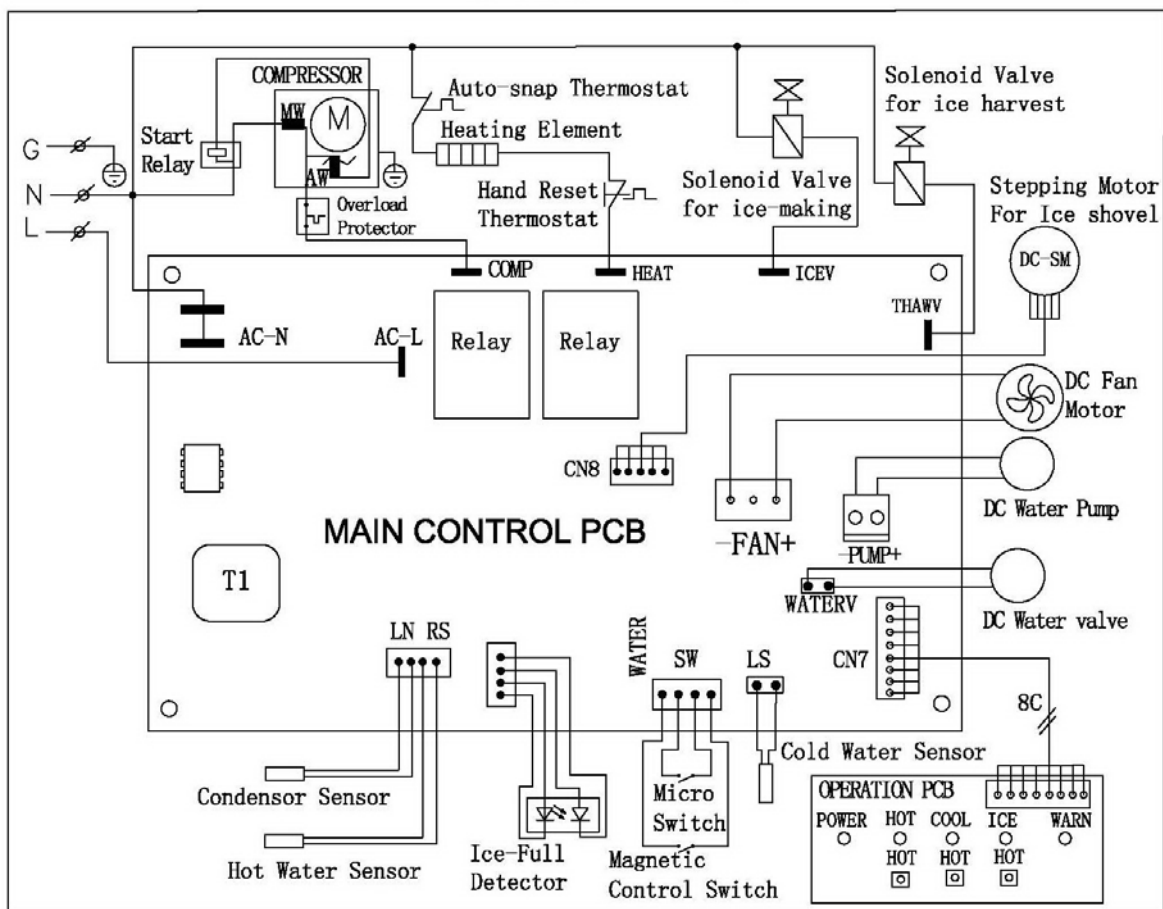

CLEAN YOU UNIT DURING REGULAR USING

After you have used your unit for three months or more, we suggest you should clean your unit again. Unplug your unit first before doing any cleaning or maintenance!

- For the outside enclosure of the unit, you can wash it with the wet soft clothe with liquid dish washing soap. Don't use erosive chemical solvent such as rubber water to wash, this maybe hurt the machine and make it change color. And don't pour water on the whole shell when washing, avoiding making its electric parts wet.
- For hot and cold water dispenser system, first twist the bottle receptacle of the non-spill

system (smart device) counterclockwise and pull it up.

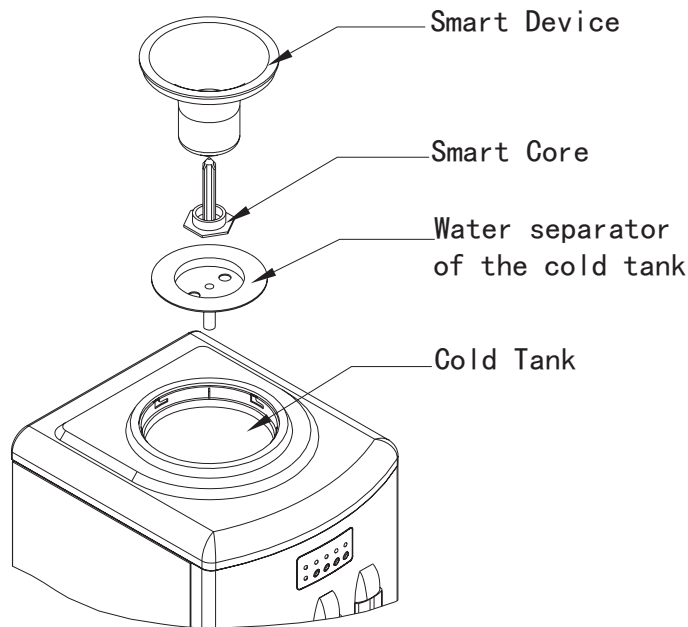

Take apart the non-spill system (smart device and smart core showed in above figure), then proceed to wash it with the dish washing fluid, rinse it and reassemble. Empty the both tanks (hot and cold) by unplugging the drain cap of the hot tank at the back of the unit. Next to clean the inside parts of the water dispenser system, use vinegar or a 2% citric acid solution to remove mineral scaling caused by the water. Rinse it well, then open the drain cap for hot tank to get the water out. Put all of the parts back, securely fasten the drain cap. It is important to let the unit dry for two hours before plugging it back in. And install back the bottle receptacle (smart device).

- For the ice-making chamber, remove the ice and water separator and ice storing plate by unscrewing the screw according following figure.

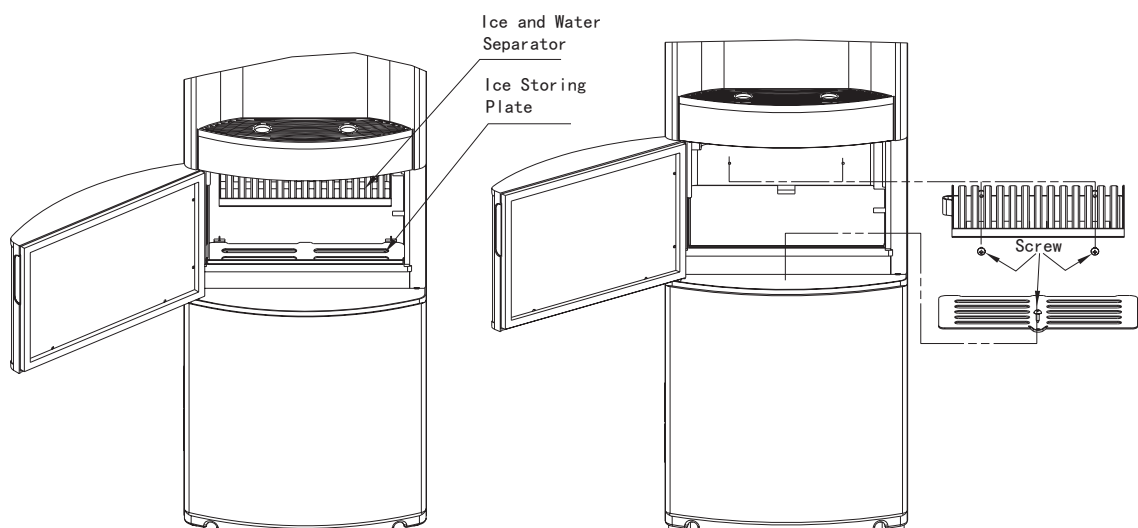

Then wash inside parts of ice-making chamber with the dish washing fluid, rinse it, and open the drain cap for ice dispenser at the back to get the water out. Rinse it for several times, then securely fasten this drain cap. To the removed ice and water separator, ice storing plate, put it into the dish washing fluid to clean it. Then rinse it and dry it. After drying, install both of

them back to original position with screw by screwdriver.

PRECAUTION

- When cleaning, the outside of the machine can be washed with the wet soft clothe. Don't use erosive chemical solvent such as rubber water to wash, this maybe hurt the machine and make it change color. Be careful that don't pour water on the whole enclosure when washing, avoiding making its internal electrical parts wet.
- Keep the unit away from the wall with proper distance, keep it far away from high temperature surrounding and prevent it from being exposed in the sunlight or other heating resource. Keep ventilation opening in the appliance enclosure or in the built-in structure, clear of obstruction.
- If you will not use the unit for a long time, please disconnect the power cord, and drain out the water from both of the drain cap. And fasten the drain cap tightly. On other condition don't touch it because it will cause the water leakage.
- Children are forbid to touch the hot tap. It is dangerous and will burn your skin.

TROUBLE SHOOTING GUIDE

If the unit works improperly, please check reference to the following table:

PROBLEM	CHECK	PROBABLE CAUSE	REMEDY
Hot and cold water, ice-maker are all not available, and the POWER indicator isn't illuminate on the control panel	Main Power Supply switch in your home	At "OFF" position	Move to "ON" position
	Power plug	Not on the power outlet	Plug it.
	Circuit breaker	Tripped	Check and reclose
	Main Fuse	Blown out	Replace
	Power breakdown	Main power supply	Wait till the main power supply resume
	Transformer	Unplug on the PCB Controller or breakdown	Call the electrician or serviceman to maintenance
	Fuse on the PCB board	Blown out	Call the electrician or serviceman to replace it with same rating.
Only hot water not available	Hot Water Button and Hot Water indicator	Hot water function is not turned on by the button on the control panel	Press the Hot Water button.
	Hot water using	The preceding amount of hot water is too much.	Wait for a moment until the hot water occurs out.
	Hot water sensor	Breakdown	Call the serviceman to replace with a new one.
Only cold water not available	Cold Water Button and Cold Water indicator on the control panel	Cold water function is not turned on by the button	Press the Cold Water button.

	Cold Water using	The preceding amount of cold water is too much.	Wait for a moment until cold water comes out.
	Air clearance between the unit and the wall	The ventilation around the apparatus is insufficient.	Space the unit from the wall by more than 15 centimeters at each side of the unit.
	Water separator in the cold tank	The cold water separator has moved in the cold water tank	Replace the water isolator at the correct position.
	Water bottle	The temperature of water supplied (in the bottle) is too high.(when the bottle is exposed to direct sunlight for a long time)	Put the water at a shady, cool place
	Ice-making	Both Ice-making and cold water function are running at same time.	Wait some more moment or stop ice-making function first.
Ice making only not available	Ice Button and Ice indicator on the control panel	Ice-making function is not turned on by the button.	Press the Ice-making button.
	Cold water function	Both Ice-making and cold water function are running at same time.	Wait some more moment or stop Cold Water function first.
Compressor not run or suddenly stops	Main power supply	Voltage too low	Contact electrician and electricity department
	Ventilation opening blocked	Blocked	Remove the block substance
	Clearance around the unit	Too small clearance, bad air circulation	Leave enough (Min. 15cm) space around the unit
	Condenser	Too dirty, produce overheated	Clean
	Cooling system	Refrigerant over charged or leaked	Contact with qualified serviceman to repair it.
	Compressor and its accessory	Breakdown	Call serviceman to check and repair it.
Warn indicator illuminate and buzz sounds	Water bottle	There is no water.	Replace with a new bottle full with drinkable water.
Warn indicator flash on the control panel	Ice-making box in the ice making chamber	The ice making box is clogged by the ice or mechanism	Stop the unit and wait for more time to let the clogged ice melt.
Water leaks from the taps or the faucet	Water faucet button	Water faucet button maybe has been clogged, can not act smoothly.	Check it, let the button go out.
	Water faucet	The water faucet has been damaged.	Call the service or the sale agent telephone number to let them change a new one.
Water is dripping out of the water dispenser and onto the floor.	Water bottle	The bottle may has small pin holes.	Change to a new bottle.
	Both of water drain cap on the	Loose	Tighten it completely check and check the sealing silicon

	back		material inside the drain cap is torn or damaged, then change to a new one.
Noise occurs	Floor	The appliance is not level.	Install it evenly and lock the unit.
	Locating position	Contact with other products.	Move it away from other products.

PRODUCT SPECIFICATION

Model	EP23573
Power Supply	115V~,60Hz
Ice-making capacity	26.4Lbs/24Hours* (Ice-making only)
Cold Water Capacity	4 L* (Cold water only)
Hot Water Capacity	5 L
Total Electrical Rating	7.3A **
Ice-making/Ice harvest Current	2A/3A **
Cold Water Current	2A**
Heating Current	4.3A
Refrigerant and quantity	R134a,3.53 Oz/100g
Design pressure (High Side)	220psig
Design pressure (Low Side)	88psig
Net Weight	40.0Lbs

TEST CONDITION: (*): Water Temperature :77°F, Room Ambient:77°F.

(**): As UL standard requirement: 104°F Room Ambient

WARNING:

- **WARNING:** Keep ventilation openings, in the appliance enclosure or in the built-in structure, clear of obstruction.
- **WARNING:** Do not damage the refrigerant circuit.

Correct Disposal of this product

	<p>This marking indicates that this product should not be disposed with other household wastes throughout the EU. To prevent possible harm to the environment or human health from uncontrolled waste disposal, recycle it responsibly to promote the sustainable reuse of material resources. To return your used device, please use the return and collection systems or contact the retailer where the product was purchased. They can take this product for environmental safe recycling.</p>
---	---

Welcome to visit our website and purchase our quality products!

Your suggestions and comments for COSTWAY are really important to us!
We sincerely solicit you to go back to our shop and leave a good rating in just a simple click. It would be quite encouraging if you could kindly do so like below:

★★★★★ Great products so far

February 24, 2019

Great products so far. Fast delivery, easy setup, and working without any issues.

With your inspiring rating, COSTWAY will be more consistent to offer you
EASY SHOPPING EXPERIENCE, GOOD PRODUCTS and EFFICIENT SERVICE!

US office: Fontana, California

UK office: Ipswich



- * Reward Points
- * Exclusive Customer Service
- * Personalized Recommendations
- * Permanent Shopping Cart
- * Order History

5 Star Rating



We would like to extend our heartfelt thanks to
all of our customers for taking time to assemble
this product and giving us valuable feedbacks.



