

## MAINTENANCE

Some simple maintenance is required to ensure your SprayPort® continues to perform effectively:  
**IMPORTANT:** Always unplug from the mains ahead of any maintenance.

- Clean/ replace filters.
  - Filters will become soiled during use. To remove see diagram below. Clean filters in warm soapy water.

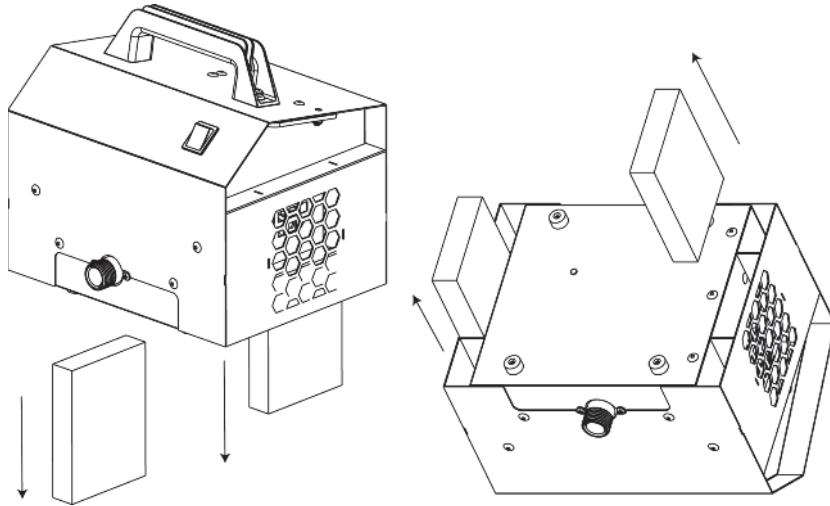

Check the condition of filter carefully and replace if necessary.

**WARNING!** Ensure filter is completely dry before installing.

- Cleaning the hose:
  - Keep the outer surface of the turbine unit clean by wiping with a damp cloth. Do not submerge into or flush through with water or any chemical. Regularly check for cracks, leaks and holes. Replace if necessary.
- Cleaning the unit:
  - Keep the outer surface of the turbine unit clean by wiping with a damp cloth. Do not submerge into water or any chemical.
- Store the unit indoors. Be careful not to twist or trap the cordset.
- No other user serviceable parts.

### **IMPORTANT:**

It is important to regularly check and clean the filters, hose and turbine, paying particular attention to the air inlets and vents. Failure to do so risks damage to the motor or premature failure.

Servicing and repairs must be carried out by authorized service centres only – contact Earlex Head Office for details.

<b>TROUBLESHOOTING</b>		
<b>PROBLEM</b>	<b>CAUSE</b>	<b>ACTION REQUIRED</b>
Little or no spray	Air inlet blocked	Check the condition of the Air Filter (1) and clean or replace Check air inlets, air vents and air hose for blockages
Turbine has no power	No power at supply	Check the power supply
	Cable fuse has blown	Where applicable check fuse and replace if necessary
	Circuit Breaker (3) has tripped	Reset the Circuit Breaker (3)
	Incorrect or damaged power cord set used	Use correct power cord set. Replace if necessary
	Worn turbine brushes	Replace brushes at an authorized service centre