

Please read this manual carefully before installation and keep it for future reference.

Installation & Owner's Manual



MRCOOL®

COMFORT MADE SIMPLE

Easy Pro™ Fast Connect®

Due to updates and constantly improving performance, the information and instructions within this manual are subject to change without notice. Please check with your retailer to ensure you have the latest version of this manual.

Version Date: 6-28-22

!	Safety Precautions	
	Warnings/Cautions	3
1	Parts Overview	
	Parts Diagram	7
	Line Set Length Specifications	7
	Display Window	8
	Accessories	9
2	Operating Instructions	
	Operating Temperature	10
	How The A/C & Heat Pump Work	11
	Airflow Directional Control	12
	Manual Operation	13
3	Care and Maintenance	
	Before Maintenance	14
	Cleaning the Unit	14
	Cleaning the Air Filter(s)	14
	Preparation for Extended Non-Operation	15
	Pre-Season Inspection	15

DISCLAIMER: You are assuming the risk by handling materials containing refrigerants under pressure, that if not handled properly, can cause bodily injury. If you do not feel comfortable conducting this installation process, we recommend you retain the services of a qualified HVAC professional.
Electrical work must be completed by a qualified electrical technician.

4 Indoor Unit Installation16

1. Installation Summary - Indoor Unit16
2. Selecting an installation location17
3. Attach Mounting Plate to Wall18
4. Drill Wall Hole for Connective Piping18
5. Prepare refrigerant piping 20
6. Mount indoor unit 20

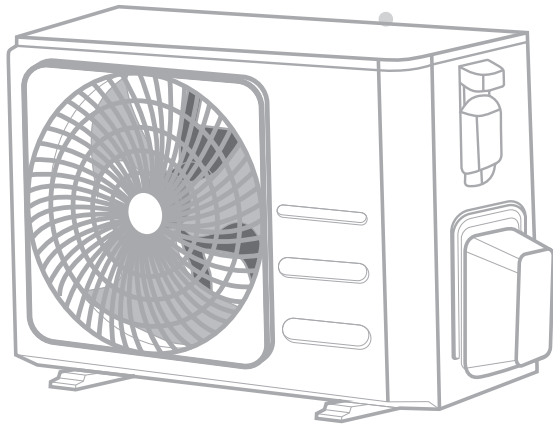
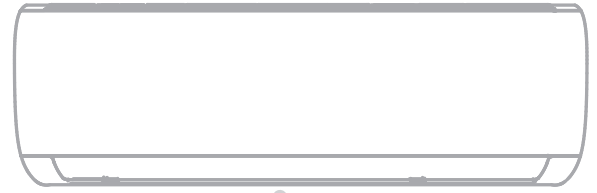

5 Outdoor Unit Installation 21

1. Selecting an installation location 21
2. Install drain joint 22
3. Anchor outdoor unit 23

6 Refrigerant Piping Connections..... 25

1. Prepare Exterior Wall Hole 25
2. Unwind Fast Connect® Line Set to necessary length ... 25
3. Connect Line Set to Indoor Unit 26
4. Connect Line Set to Outdoor Unit 28
5. Opening Refrigerant Valves of Outdoor Unit 30
6. Connect drain pipe 31
7. Wrap Piping Connections 32

7 Electrical Connections 34

8 Electrical and Gas Leak Checks..... 37

9 Test Run..... 38

10 Troubleshooting..... 40

11 EU Disposal Guide..... 43

Safety Precautions



Read Before Using

Incorrect usage may cause serious damage or injury.

The symbols below are used throughout this manual to indicate instructions that should be followed closely or actions that should be avoided to prevent death, injury, and/or property damage.



WARNING

This symbol indicates ignoring instructions may cause death or serious injury



CAUTION

This symbol indicates ignoring instructions may cause bodily injury, damage to the unit, or other surrounding property.



This symbol indicates that you should NEVER perform the indicated action.



WARNINGS FOR PRODUCT USE

If the unit begins to operate abnormally, or any of the following occur, turn off the unit immediately and disconnect the power in order to avoid electric shock, fire, or personal injury. Then, contact your authorized dealer or technical support.

- Signal/power cable is damaged or abnormally warm
 - Burning odor
 - Loud or abnormal sounds
 - A power fuse or circuit breaker trips frequently
 - Water or other objects fall into or out of the unit
- ⊘ **DO NOT** insert your fingers, rods or any other objects into the air inlet or outlet, as the high-speed fan may be rotating, and this could result in injury.
- ⊘ **DO NOT** use flammable aerosol sprays such as hair spray, lacquer, or paint near the unit.
- ⊘ **DO NOT** operate the unit near or around combustible gas. Emitted gas may collect around the unit and could cause an explosion.
- ⊘ **DO NOT** operate your air conditioner in a room where it could be exposed to water such as a bathroom or laundry room. Exposure to excessive amounts of water may cause electrical components to short circuit.
- ⊘ **DO NOT** expose your body directly to cool air for a prolonged period of time.
- ⊘ **DO NOT** allow children to play with the unit. Children must be supervised at all times when near the unit.
- If the air conditioner is used with burners or other heating devices, ensure that the room is thoroughly ventilated in order to avoid an oxygen deficiency.
 - In certain functional environments such as kitchens, server rooms, etc., the use of specially designed air-conditioning units is highly recommended.
 - This appliance is not intended for use by individuals (including children) with reduced physical, sensory, or mental capabilities. It is also not intended for use by individuals with a lack of experience or knowledge, unless they have been given supervision or instruction concerning use of the appliance by a person responsible for their safety. Children (above the age of 8) can use this appliance, but should be supervised at all times to ensure that they do not play with the appliance. Cleaning and user maintenance, however, should not be made by children, without supervision (European Union Countries).



WARNINGS FOR PRODUCT INSTALLATION

1. Installation must be performed according to the installation instructions. Improper installation can cause water leakage, electrical shock, and/or fire. In North America, installation must be performed in accordance with the requirements of the NEC and CEC.
2. Contact an authorized service technician for repair or maintenance of this unit.
3. Only use the included accessories, parts, and specified parts for installation. The use of non-standard, aftermarket parts could cause water leakage, electrical shock, fire, and/or cause the unit to fail.
4. Ensure the unit is installed in a firm, solid location that can support the unit's weight. If location chosen for installation is not able to support the weight of the unit, or the installation is completed improperly, it could cause the unit to drop. This could result in serious injury and/or property damage.
5. Install a drainage pipe according to the instructions provided in this manual. Improper drainage may cause water damage to your home or other property.
6. For units that have an auxiliary electric heater, **DO NOT** install the unit within 3 feet (1 m) of any combustible materials.
7. **DO NOT** install the unit in a location that may be exposed to combustible gas leaks. If combustible gas accumulates around the unit, it could cause an explosion, fire, and/or personal injury.
8. **DO NOT** turn on the power until all work has been completed.
9. When moving or relocating the air conditioner, consult an experienced service technician for disconnection and reinstallation of the unit.
10. For more information on how to install the indoor and outdoor unit to their supports, please refer to the respective indoor and outdoor unit installation sections of this manual.

Note about Fluorinated Gasses (Not applicable to the unit using R290 Refrigerant)

1. This air-conditioning unit contains fluorinated greenhouse gasses. For specific information about the type of gas, and the amount please refer to relevant label on the unit, or the Manual contained in packaging of the outdoor unit.
2. Product un-installation and recycling must be performed by a certified technician.
3. For equipment that contains fluorinated greenhouse gasses in quantities of 5 tonnes of CO₂ equivalent or more, but of less than 50 tonnes of CO₂ equivalent, if the system has a leak-detection system installed, it must be checked for leaks at least every 24 months.
4. When the unit is checked for leaks, proper record keeping of all checks is strongly recommended.

Take Note of Fuse Specifications

The circuit board (PCB) of the air conditioner is designed with a fuse to provide overcurrent protection. The specifications of this fuse are printed on the circuit board, such as:

T3.15AL/250VAC, T5AL/250VAC, T3.15A/250VAC, T5A/250VAC, T20A/250VAC, T30A/250VAC, etc.

NOTE: For units using R32 or R290 refrigerant, only blast-proof ceramic fuse can be used.



ELECTRICAL WARNINGS

1. Only use the specified power cord. If the power cord is damaged in any way, it must be replaced by the manufacturer, its service agent, or a similarly qualified person in order to avoid a potential hazard.
2. Keep the plug of the power cord clean by removing any dust or dirt that accumulates on or around the plug. A plug which is dirty can cause electric shock and/or a fire.
3. ***DO NOT*** pull the power cord to unplug the unit from the outlet. Hold the plug firmly and pull it from the outlet. Pulling directly on the cord can damage it, which can lead to electric shock and/or fire.
4. ***DO NOT*** modify the length of the power supply cord or use an extension cord to power the unit.
5. ***DO NOT*** share the electrical outlet with other appliances. Improper or insufficient power supply can cause electrical shock and/or fire.
6. The product must be properly and securely grounded at the time of installation, or electrical shock could occur.
7. All electrical wiring and work must be installed and performed in accordance with all local and national wiring standards, regulations, and the installation manual. Ensure cables are connected tightly and securely clamped to prevent external forces from damaging the terminal. Improper electrical connections must be made according to the electrical connection diagram located on the panels of the indoor and outdoor units.
8. All wiring must be properly arranged to ensure that the control board cover can close properly. If the control board cover cannot close, it could lead to corrosion and cause the connection points of the terminal to overheat, catch fire, and/or cause electric shock.
9. If connecting power to fixed wiring, the following must be incorporated within it, in accordance with the wiring rules; an all-pole disconnection device (which has at least 3 mm of clearances in all poles), and have a leakage current that may exceed 10mA, the residual current device (RCD) having a rated residual operating current not exceeding 30mA, and disconnection all must be present.



CLEANING & MAINTENANCE WARNINGS

- ⊘ ***DO NOT*** attempt to clean the unit with the device on and the power connected. Turn off the device and disconnect the power before cleaning in order to prevent electrical shock.
- ⊘ ***DO NOT*** clean the air conditioner with excessive amounts of water.
- ⊘ ***DO NOT*** clean the unit with combustible cleaning agents as these could cause a fire or deformation of some of the parts of the unit.



WARNING

In the case of ANY of the following, turn off the unit immediately!

- Signal/power cable is damaged or abnormally warm
- Burning odor
- Loud or abnormal sounds
- A power fuse or circuit breaker trips frequently
- Water or other objects fall into or out of the unit

DO NOT ATTEMPT TO CORRECT THESE ITEMS YOURSELF!

CONTACT A SERVICE PROFESSIONAL IMMEDIATELY.

CAUTION

- If the air conditioner will not be used for an extended period of time, turn off the unit and disconnect the power.
- Turn off the unit and disconnect the power during storms.
- Ensure water condensation can drain from the unit easily.
- ⚠ ***DO NOT*** operate the air conditioner with wet hands, as this could cause electrical shock.
- ⚠ ***DO NOT*** use device for any other purpose than its intended use.
- ⚠ ***DO NOT*** climb onto or place objects on top of the out door unit.
- ⚠ ***DO NOT*** allow the air conditioner to operate for long periods of time with doors or windows open, or in high levels of humidity.

Parts Overview

1

NOTE: The installation must be performed in accordance with the requirement of local and national standards. The installation process may be slightly different in different areas.

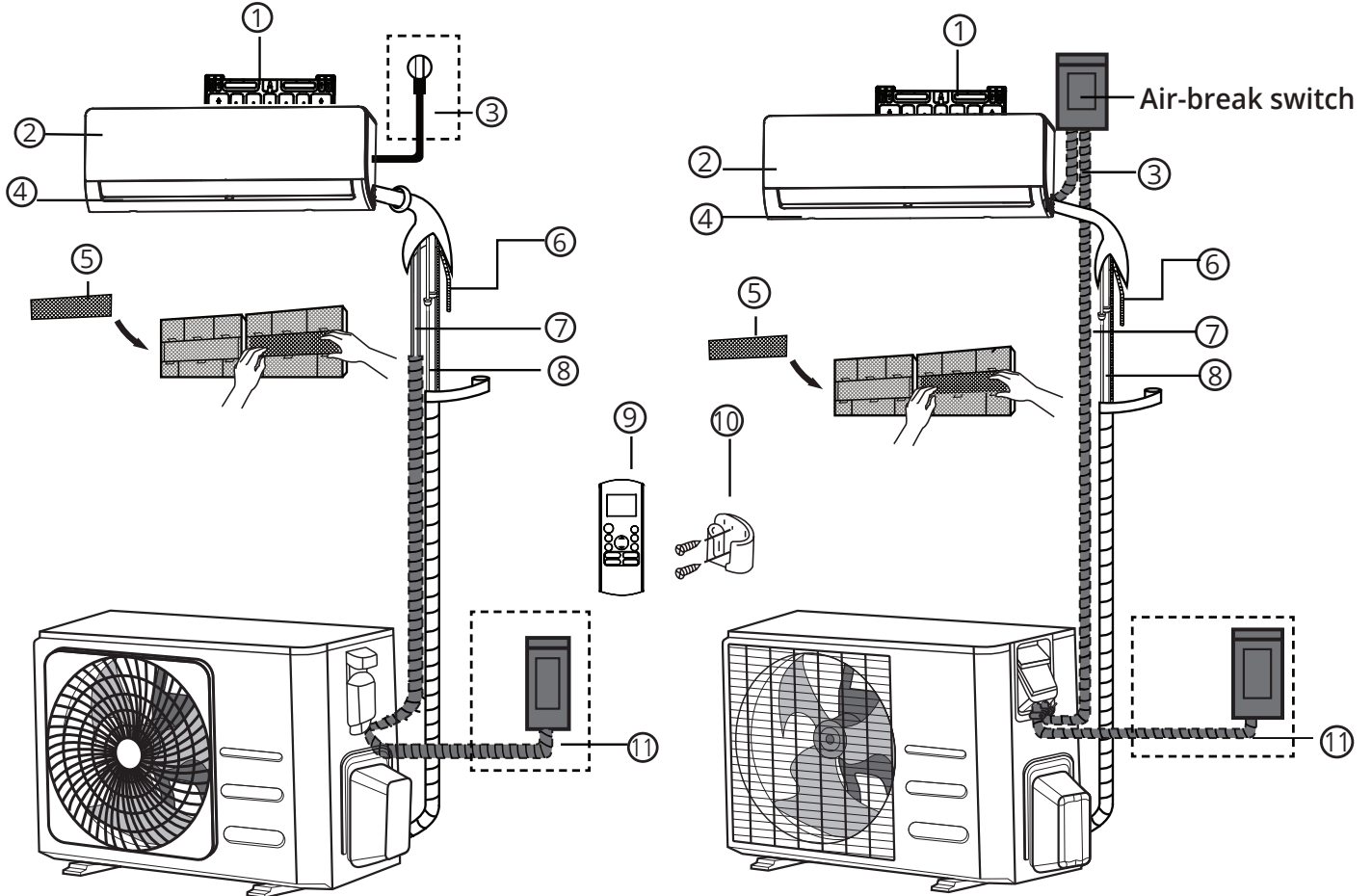

(1)

(2)

- ① Wall Mounting Plate
- ② Front Panel
- ③ Power Cable (Some Units)
- ④ Louver
- ⑤ Functional Filter (On Back of Main Filter - Some Units)
- ⑥ Drainage Pipe
- ⑦ DIYPRO™ Cable
- ⑧ Fast Connect® Line Set
- ⑨ Remote Controller
- ⑩ Remote controller Holder (Some Units)
- ⑪ Outdoor Unit Power Cable (Some Units)

Maximum Line Set Length and Height Specifications*

System Capacity	9K System	12K System	18K System	24K System
Maximum line set length	82 ft (25 m)	82 ft (25 m)	98 ft (30 m)	164 ft (50 m)
Maximum height difference between indoor & outdoor unit	33 ft (10 m)	33 ft (10 m)	66 ft (20 m)	82 ft (25 m)

Units: feet (meters)

* The table above represents the maximum length and height that the refrigerant line sets can be for each system based on its respective capacity. In order to achieve some of these lengths, line set coupler kits and additional line sets must be used (not included, sold separately). Any attempt to increase the line set length beyond what is specified in the table above, could result in reduced heating/cooling performance, system damage or failure, and **WILL VOID THE WARRANTY**.

Indoor Unit Display Window

NOTE: Different models have different front panels and display windows. Not all of the functions/display codes described below are available for the air conditioner you purchased. Please check the indoor display window of the unit you purchased.

Illustrations in this manual are for explanatory purposes. The actual shape of your indoor unit may be slightly different.

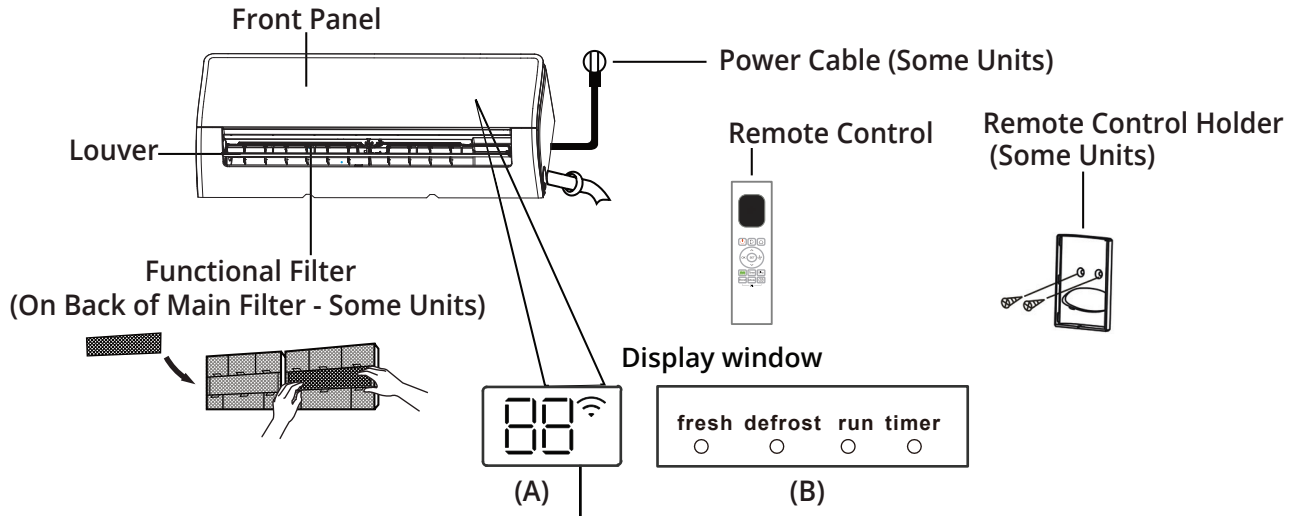

“fresh” when Fresh (if any) feature is activated (some units).

“defrost” when defrost feature is activated.

“run” when the unit is on.

“timer” when TIMER is set.

“” when Wireless Control feature is activated (some units).

“88” Displays temperature, operation feature and error codes:

“” for 3 seconds when:

- TIMER ON is set (if the unit is OFF, “” remains on when TIMER ON is set)
- FRESH, SWING, TURBO, ECO, or SILENCE feature is turned on

“” for 3 seconds when:

- TIMER OFF is set
- FRESH, SWING, TURBO, ECO, or SILENCE feature is turned off

“” when defrosting











“” when 8°C heating feature is turned on (some units)





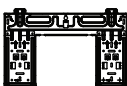



“” when Active Clean feature is turned on

Display Code Meanings

Overview - Accessories

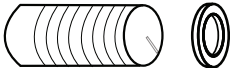
The listing below shows the accessories and parts (these may vary depending on purchase & options). Use all of the installation parts and accessories to install the system. Improper installation may result in water leakage, electrical shock, fire, and/or equipment failure.

PART	QUANTITY	LOOKS LIKE...	PART	QUANTITY	LOOKS LIKE...
Manual	2~3		Remote controller	1	
Drain joint (for cooling & heating models)	1		Battery	2	
Seal (for cooling & heating models)	1		Remote controller holder(optional)	1	
Mounting plate	1		Fixing screw for remote controller holder(optional)	2	
Anchor	5~8 (depending on model)		Small Filter (Need to be installed on the back of main air filter)	1~2 (depending on models)	
Mounting Plate Screw	5~8 (depending on models)				

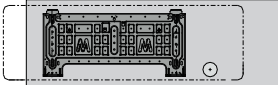
PART	LOOKS LIKE...	QUANTITY
Fast Connect® Refrigerant Pipe Line Set		1
Sound Deadening Pad		2 (used to wrap up the Fast Connect® connectors)
DIYPRO™ Cable		1 (Already connected to the air handler)
Insulation sheath		2 (apply to the Fast Connect® connectors)
Plastic Wall Sleeve & Cap		1
Drain Pipe		1 16 ft (5 m)
Non-Adhesive U.V. Tape		1
Neoprene		1 (sealant for wall sleeve)
Cardboard Mounting Plate Template		1

Operating Temperature Range

When your air conditioner is operated outside of the following temperature ranges, certain safety protection features may activate and cause the unit to disable.

	COOL mode	HEAT mode	DRY mode
Room Temperature	60°F - 90°F (16°C - 32°C)	32°F - 86°F (0°C - 30°C)	50°F - 90°F (10°C - 32°C)
Outdoor Temperature	32°F - 122°F (0°C - 50°C)		
	5°F - 122°F (-15°C - 50°C) (For models with low temp. cooling systems)	5°F - 75°F (-15°C - 24°C)	32°F - 122°F (0°C - 50°C)

FOR OUTDOOR UNITS WITH AUXILIARY ELECTRIC HEATER

When outside temperature is below 32°F (0°C), we strongly recommend keeping the unit plugged in at all times to ensure smooth and continuous performance.

NOTE: If the air conditioner runs for an extended period of time in cooling mode and the humidity is high (above 80%), condensed water may drip out of the unit. If this should occur, set the vertical air flow louver to its maximum angle (vertical toward the floor), and set the unit to HIGH fan mode.

Optimal Operation

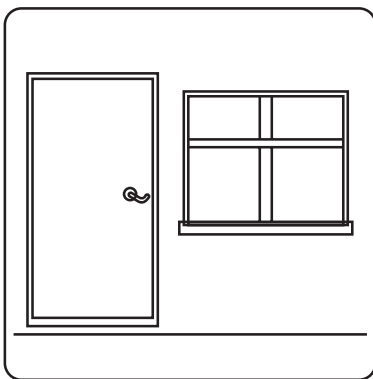

Doors and windows should be kept closed

To achieve optimal performance, please note the following:

- Keep doors & windows closed.
- Limit energy usage by using **TIMER ON** and **TIMER OFF** functions.
- Do not block air inlets or outlets.
- Regularly inspect and clean air filters.

How the air conditioner works

Basic Operation Modes:

AUTO/COOL/DRY/HEAT (Model Dependent)

OTHER FEATURES

NOTE: A guide on using the infrared remote is not included. Not all of the functions listed below are available on your unit. Please check the indoor display and remote control of the unit you have purchased.

Auto-Restart (some units)

If the unit loses power, such as during a power outage, it will automatically restart with the prior settings once the power has been restored.

Anti-Mildew (some units)

When the unit is turned off, while in **COOL, AUTO (COOL)**, or **DRY** mode, it will continue to operate at very low power to dry up condensed water and prevent the growth of mildew.

Active Clean function (some units)

The Active Clean Technology is designed to wash away dust that has accumulated to the heat exchanger. It does this by automatically freezing to create frost, and then rapidly thawing it. This process will create more condensed water which will make the cleaning process more effective. The fan will blow the cold air produced out. Once the cleaning process has completed, the internal fan will then circulate hot air through the system to blow-dry the evaporator, thus keeping the inside of the unit clean. Some noises may be heard from the unit during this process. These are normal.

- When this function is activated the indoor unit display will show "CL," after 20 to 130 minutes, the unit will turn off automatically and cancel the Active Clean function.
- For some units, the system will start the high-temperature cleaning process. The temperature of the air exiting the air outlet will be very high. Please keep away from it, as it could cause injury. This may also cause the temperature of the room to rise, until operation is complete.

Wireless Control (some units)

Wireless control allows you to control the unit from your mobile phone and a wireless connection. For USB device access, replacement or maintenance operations must be performed by qualified staff.

Louver Angle Memory (some units)

When the unit is turned on, the directional airflow louver will return to the previous angle/setting when it was last used.

Breeze Away (some units)

This feature keeps airflow from the unit from directly blowing on room occupants.

Refrigerant Leakage Detection (some units)

The indoor unit will automatically display "ELOC" or LEDs will flash (model dependent) when a refrigerant leak is detected.

Sleep Operation

The **SLEEP** function is used to decrease the energy usage of the system while you sleep by slightly adjusting the temperature settings. During sleep you do not need the same temperature setting to stay comfortable. This function can only be activated via the remote control. This function is not available while the system is in **FAN** or **DRY** modes. Press the **SLEEP** button when you are ready to go to sleep. When the system is in **COOL** mode, the unit will automatically increase the temperature by 2°F (1°C) after one hour, and will increase an additional 2°F (1°C) after another hour. When in **HEAT** mode, the unit will decrease the temperature by 2°F (1°C) after one hour, and will decrease an additional 2°F (1°C) after another hour. This feature will stop after eight hours and return to the previously set temperature.

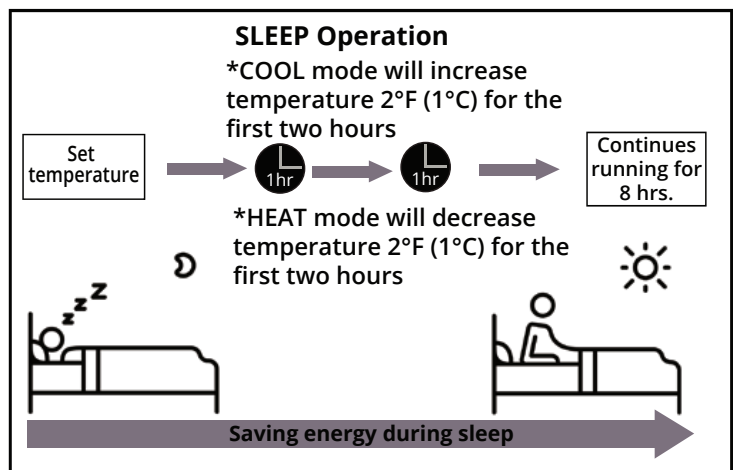

Airflow Directional Control

- Adjustment of the vertical and horizontal louvers will change airflow direction of the indoor unit to prevent discomfort and/or uneven room temperatures.
- Adjust the vertical louver using the remote.
- Adjust the horizontal louver manually.

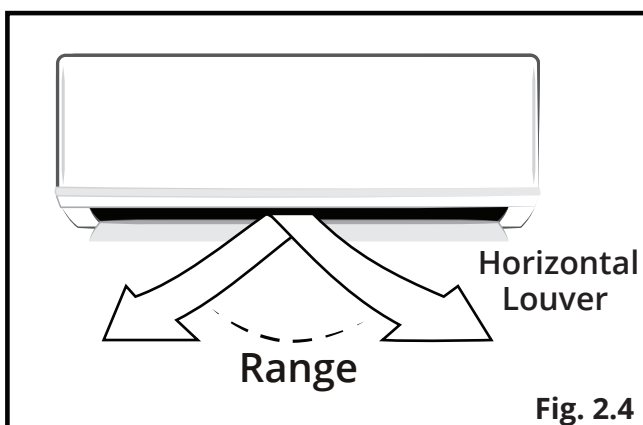
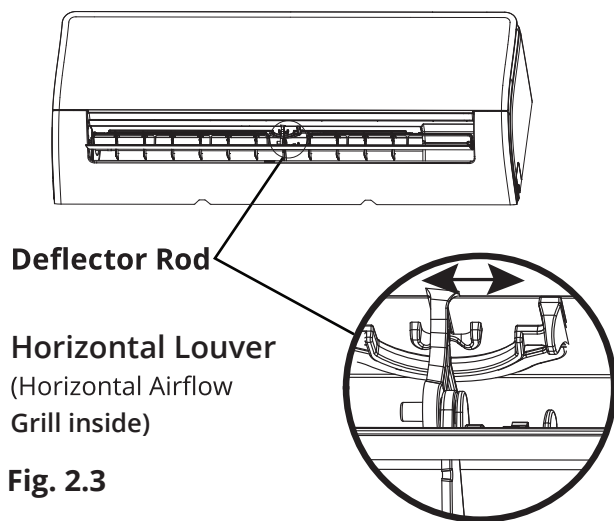
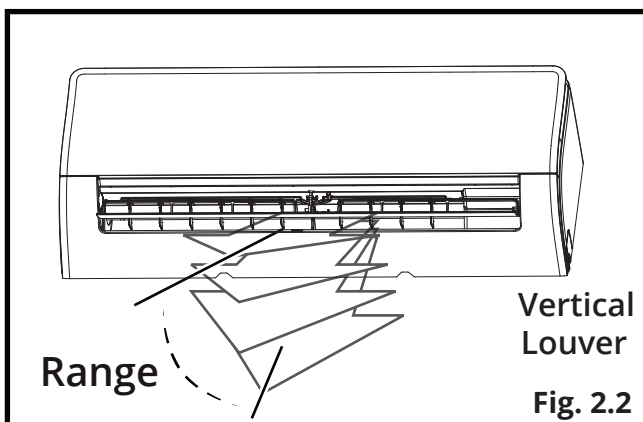

Adjust Vertical Airflow (Up/Down) using Vertical Louver (Fig 2.2):

This function is performed by using the remote control and pressing the **SWING/DIRECT** button while the unit is operating. Please refer to the "**Remote Control User Manual**" for further details.

Adjust Horizontal Airflow (Left/Right) using Horizontal Louver (Fig 2.3 & Fig 2.4)

Move the deflector rod, located on the underside of the unit, by pushing the tab to manually adjust the airflow from side to side as desired. For some units, the horizontal angle of the airflow can be set using the remote control. Please refer to the **Remote Control Manual**.

! CAUTION

- ⊘ **DO NOT** put your fingers into the panel of the blower and suction side. The high speed fan inside may cause injury.
- ⊘ **DO NOT** operate the unit for long periods of time in **COOL** or **DRY** mode with the airflow direction of the louver set at an extreme vertical angle. This could cause condensation to form on the surface of the vertical louver and allow moisture to drop onto furnishings or the floor.

NOTE: When using **COOL** or **HEAT** mode, setting the louver at an extreme vertical angle can inhibit the performance of the unit because it will restrict airflow.

- ⊘ **DO NOT** move the vertical louver manually, as this could cause it to become out of sync. If this occurs, follow these steps:
 1. Turn off power to the unit.
 2. Unplug the unit from the wall outlet.
 3. Wait a few seconds and plug the unit back in and turn it on.
 4. This will reset the louver.

NOTE: After a quick restart, the vertical louver may remain static for approximately 10 seconds.

Manual Operation (without remote)

CAUTION

Units are equipped with a button to run emergency operation mode or for testing purposes. This button is used for manual operation in case the remote control fails, or maintenance is necessary. Please do not use this function unless it is absolutely necessary. An example of acceptable use would be if the remote control was lost. The button can be accessed by opening the front panel, however, the unit must be turned off before the manual operation function can be used.

To operate your unit manually:

1. Open the front panel of the indoor unit.
2. Locate the **MANUAL CONTROL button** on the right-hand side of the unit. Please refer to the image below.
3. Pressing the **MANUAL CONTROL button** once will activate **FORCED AUTO** mode. Pressing it again will activate the **FORCED COOLING** mode. Pressing the button a third time will turn the unit off.
4. Close the front panel.

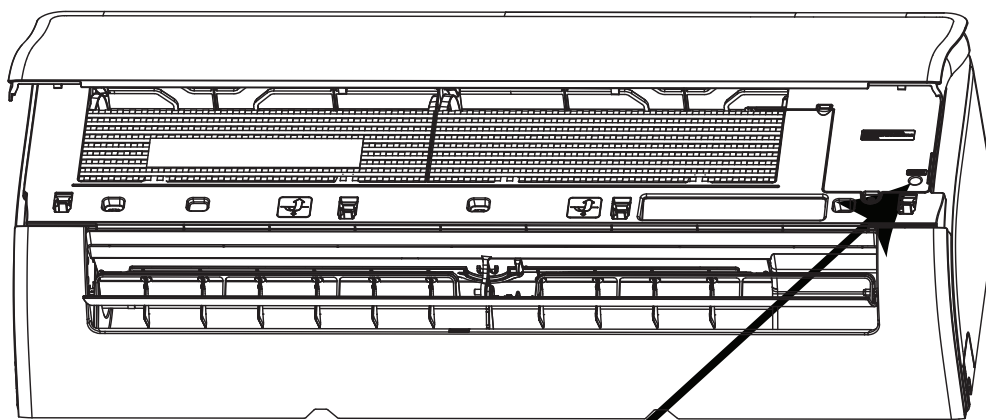

Manual Control Button

! CAUTION

Power supply must be disconnected before attempting any kind of cleaning or service. Before performing maintenance, turn the power off to the unit and then disconnect the power to the circuit at the breaker. Failure to do this could cause electrical shock.

- ⊘ **DO NOT** use benzene, thinner, polishing powder, or similar solvents for cleaning. These may cause the plastic surface to crack and/or deform.
- ⊘ **DO NOT** clean the unit with excessive amounts of water.
- ⊘ **DO NOT** touch the metal parts of the unit when removing the filter. Injuries can occur when handling the sharp metal edges.
- ⊘ **DO NOT** use water to clean inside the air conditioner. Exposure to water can destroy the insulation, leading to possible electric shock.

- ⊘ **DO NOT** use a chemically treated cloth or duster to clean the unit.
- ⊘ **DO NOT** touch air freshening (Plasma) filter for at least 10 minutes after turning off the unit.
- ⊘ **DO NOT** clean the unit with combustible cleaning agents. These could cause fire or deformation.
- ⊘ **DO NOT** wash air filter with hot water.
- ⊘ **DO NOT** expose the filter to direct sunlight, it may cause it to shrink. Allow it to dry in the shade.
- ⊘ **DO NOT** expose the filter to any heat source including sunlight or forced hot air of any kind. This could damage the filter.

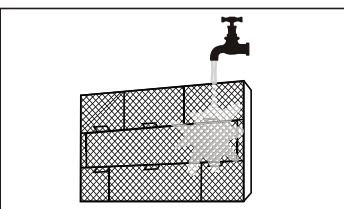
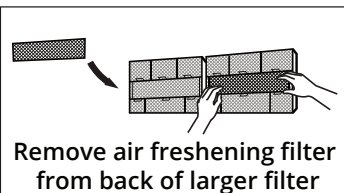
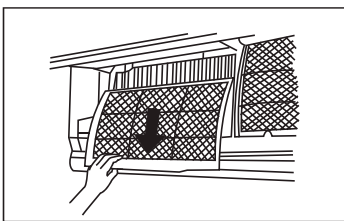
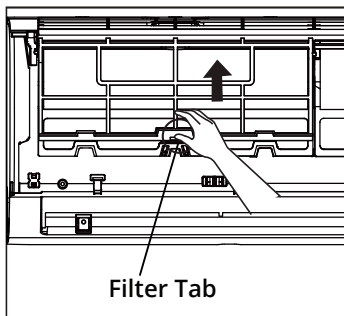

Cleaning the Unit:

Wipe the unit with a soft dry cloth. If the unit is very dirty, wipe it with a cloth soaked in warm water. **DO NOT use bleach or abrasives.**

Cleaning the Air Filter and Air Freshener:

NOTE: A clogged air filter can greatly reduce heating and cooling efficiency of this unit. It is recommended to clean the unit every 2 weeks.

1. Lift the front panel of the indoor unit.
2. Then, press the tab on the end of the filter to loosen the buckle, lift it up, and then pull the filter towards you.
3. You should now be able to pull the filter out.
4. If the filter has a smaller air freshening filter contained within it, unclip it from the larger filter. Clean the smaller filter with a handheld vacuum.
5. Clean the larger filter with warm, soapy water. Be sure to use a mild detergent.
6. Rinse the filter with fresh water, then shake off the excess water.
7. Allow it to dry in cool, dry place. **DO NOT** allow it to be exposed to direct sunlight.
8. After the filter has dried, reclip the air freshening filter to the larger filter and reinstall it into the unit.
9. Close the front panel of the indoor unit.

Air Filter Reminders (Optional)

Air Filter Cleaning Reminder

After 240 hours of use, the display window on the indoor unit will flash "CL." This is a reminder to clean your filter. After 15 seconds the unit will revert to the previous display.

To reset the reminder, press the **LED button** on your remote control 4 times, or press the **MANUAL CONTROL** button 3 times. If you do not reset the reminder, the "CL" indicator will flash again when you restart the unit.

Air Filter Replacement Reminder

After 2,880 hours of use, the display window on the indoor unit will flash "nF." This is a reminder to replace your filter. After 15 seconds the unit will revert to the previous display.

To reset the reminder, press the **LED button** on your remote control 4 times, or press the **MANUAL CONTROL** button 3 times. If you do not reset the reminder, the "nF" indicator will flash again when you restart the unit.

Preparation for Extended Non-Operation

If you plan to not run the unit for an extended period of time (e.g. from the end of summer to the beginning of the following summer), perform the following:

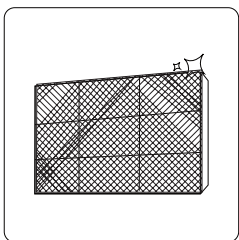

Clean all filters

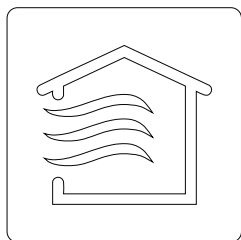

Turn on FAN mode until unit dries out completely

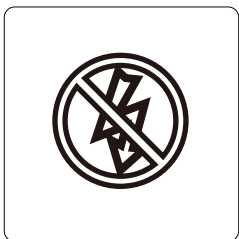

Turn off the unit and disconnect the power

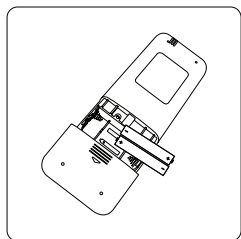

Remove batteries from remote control

Pre-Season Inspection

After prolonged non-operation, or before periods of frequent use, perform the following:

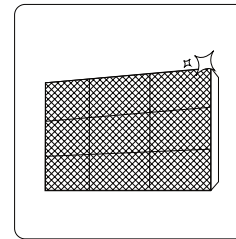
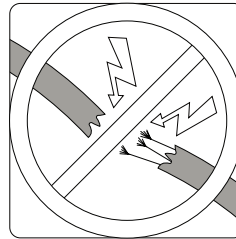

Check for damaged wires Clean all filters

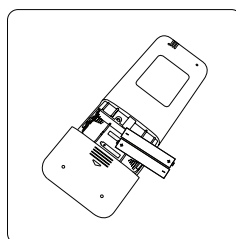

Check for leaks Replace batteries

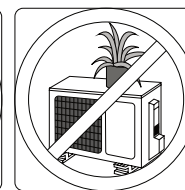
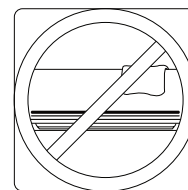

Make sure nothing is blocking all air inlets and outlets

! CAUTION

- Any repairs to the unit should be performed by an authorized dealer or a licensed service provider.

Installation Summary - Indoor Unit

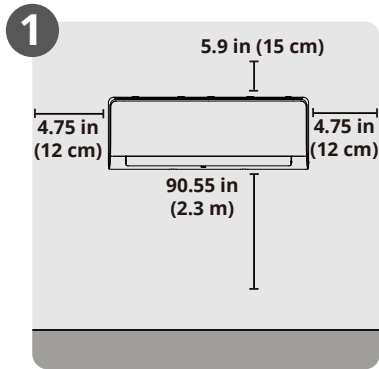

1
Select Installation Location

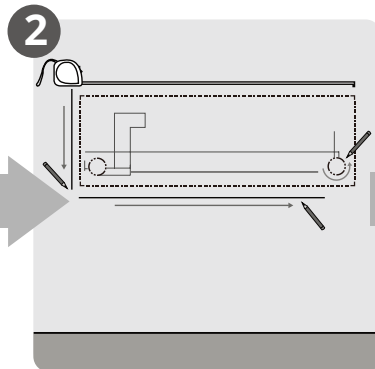

2
Determine Wall Hole Position

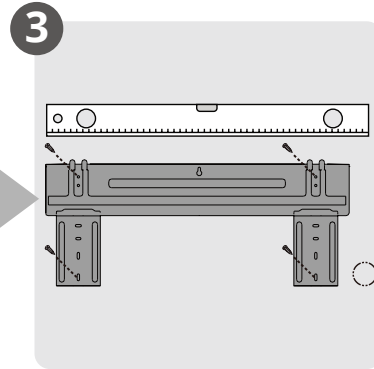

3
Attach Mounting Plate

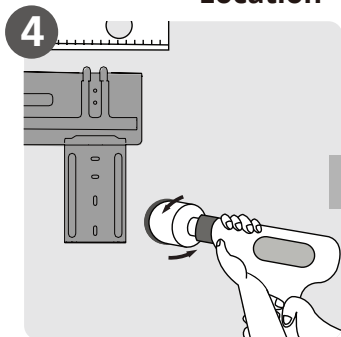

4
Drill Wall Hole

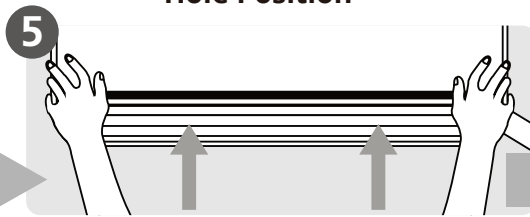

5
Mount Indoor Unit to Mounting Plate

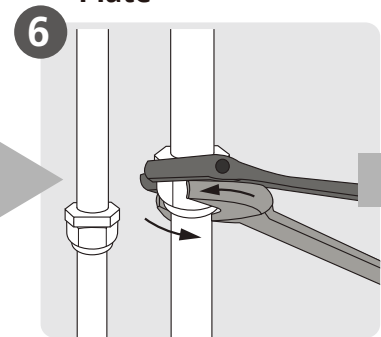

6
Connect Piping

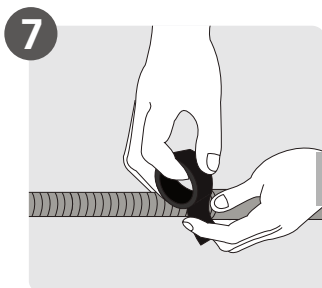

7
Prepare Drain Hose

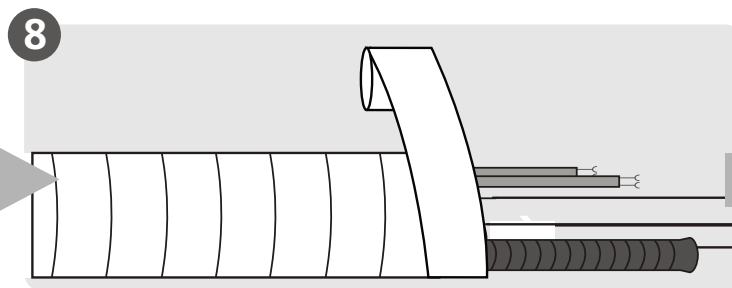

8
Wrap Piping and Cable
(not applicable for some locations in the US)

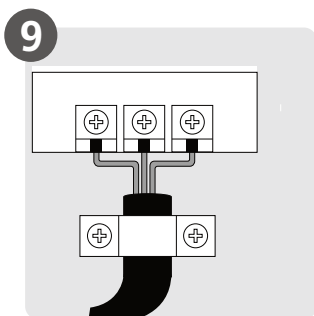

9
Connect Wiring to Outdoor Unit
(once installed)

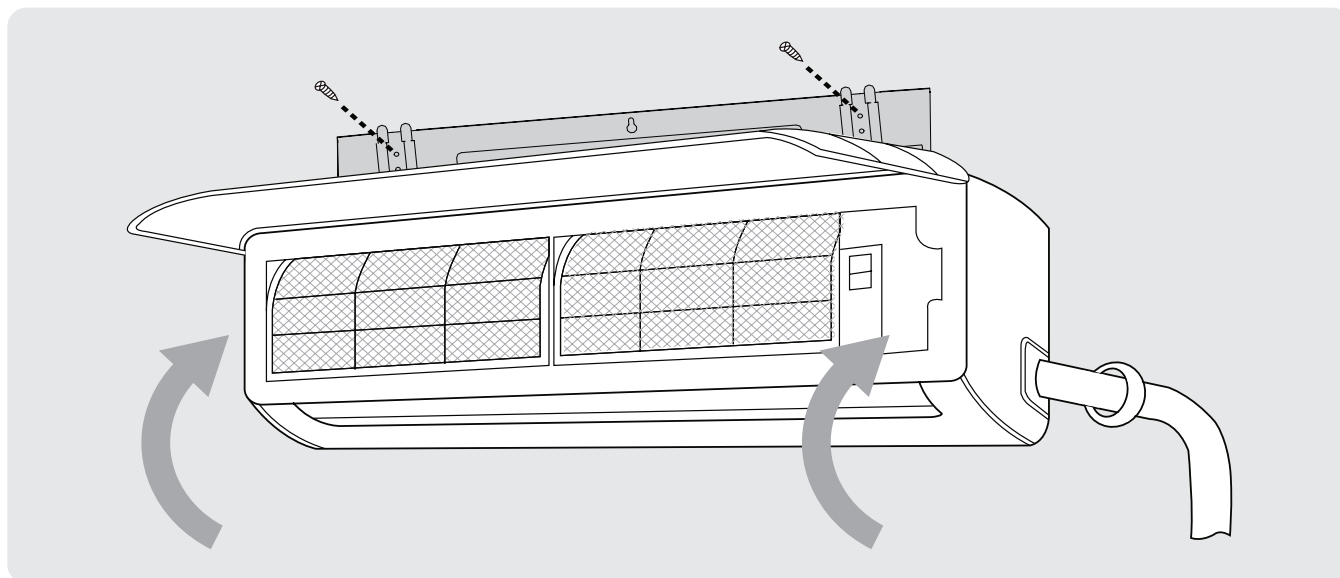

Installation Instructions - Indoor Unit

PRIOR TO INSTALLATION:

Before installing the indoor unit, refer to the label on the product box to make sure that the model numbers of the indoor unit and the outdoor unit match.

Step 1: Selecting an installation location

Before installing the indoor unit, you must choose an appropriate location. The following standards will help you choose an appropriate location for the unit.

Proper installation locations meet the following standards:

- ✓ Good air circulation
- ✓ Convenient drainage
- ✓ Noise from the unit will not disturb other people
- ✓ Firm and solid—the location will not vibrate
- ✓ Strong enough to support the weight of the unit
- ✓ A location at least one meter from all other electrical devices (e.g., TV, radio, computer)

DO NOT install unit in the following locations:

- ⊘ Near any source of heat, steam, or combustible gas
- ⊘ Near flammable items such as curtains or clothing
- ⊘ Near any obstacle that might block air circulation
- ⊘ Near a doorway or where outside air may blow directly on indoor unit
- ⊘ In a location subject to direct sunlight

NOTE ABOUT WALL HOLE:

If there is no fixed refrigerant piping: While choosing a location, be sure that you leave ample room for a wall hole (see the Drill Wall Hole for Connective Piping step on the following pages) for the signal cable and refrigerant piping, which connect the indoor and outdoor units. The default position for the wall hole is the right-hand side of the indoor unit (while facing the front of the unit). However, the unit can accommodate left or right wall hole. After the piping and signal wire are installed, use the provided neoprene (spray foam can be used instead, if you prefer) to pack the space left in hole, in order to seal it and make it airtight.

Refer to Fig. 4.2 below to ensure proper distance from walls, ceiling, and floor when mounting unit:

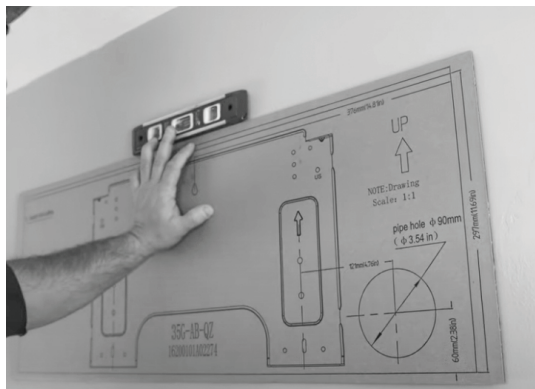

Fig. 4.1

Step 2: Attach mounting plate to wall

The mounting plate is the device on which you will mount the indoor unit.

1. Remove the screw that attaches the mounting plate to the back of the indoor unit.
2. Place the mounting plate against the wall in a location that meets the guidelines in the **Selecting an Installation Location** step. Refer to the **Mounting Plate Dimensions** section for detailed information on mounting plate sizes.

NOTE

A cardboard template of the mounting plate is included to be used as a more manageable way of determining where to mount the mounting plate and drill the wall hole. It can be placed against the wall in place of the actual mounting plate for the previous step (See Fig 4.1).

3. Drill holes for mounting screws in places that:
 - have studs and can support the weight of the unit
 - correspond to screw holes in the mounting plate
4. Secure the mounting plate to the wall with the screws provided.
5. Make sure that mounting plate is flat against the wall.

NOTE FOR CONCRETE OR BRICK WALLS:

If the wall is made of brick, concrete, or a similar material, drill 0.2 in. diameter (5 mm diameter) holes in the wall and insert the sleeve anchors provided. Secure the mounting plate to the wall by tightening the screws directly into the anchors.

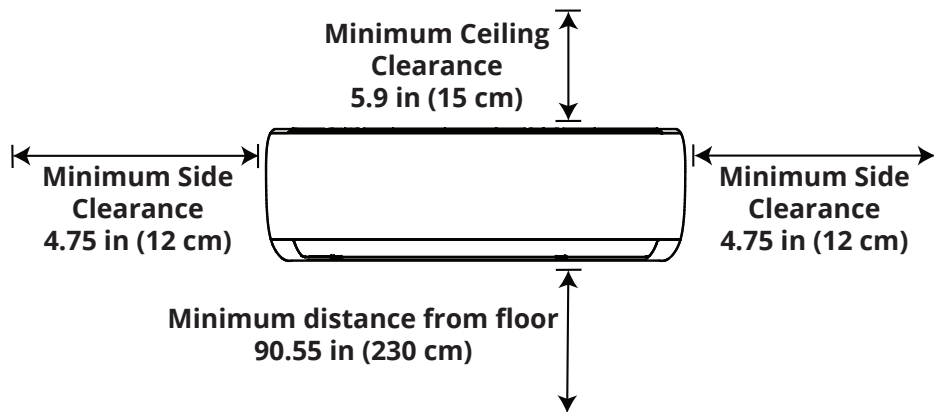

Fig. 4.2

Step 3: Drill wall hole for connective piping

You must drill a hole in the wall for the refrigerant piping, drainage pipe, and DIYPRO™ Cable to pass through in order to connect the indoor and outdoor units.

1. Determine the location of the wall hole based on the position of the mounting plate. Refer to the **Mounting Plate Dimensions (See Fig 4.5)** to assist you in determining the optimal position for the hole, based on the type of mounting plate provided with your unit.
2. Using a core drill, with a 2.5 in (65 mm) or 3.54 in (90 mm) diameter (depending on model), drill a hole in the wall at a slight downward angle, so that the indoor end of the hole is higher than the outdoor end of the hole, by approximately 0.2 in to 0.275 in (5 mm to 7 mm). This will ensure proper water drainage from the indoor unit (**See Fig. 4.3**). **NOTE: When gas piping is 5/8 in (16 mm) or larger, the wall hole should be drilled with a core drill that has a diameter of 3.54 in (90 mm).**
3. Insert the protective wall sleeve through the hole of the inside wall, noting the amount it protrudes from the exterior wall. Then, trim the excess, with a utility knife or a saw, to make it flush with the exterior wall. This will protect the edges of the hole and help seal it when you finish the installation process (**See Fig 4.4**).

! CAUTION

When drilling the wall hole, be sure to avoid wires, plumbing, nails, screws, and other sensitive components.

MOUNTING PLATE DIMENSIONS

Different models have different mounting plates. In order to ensure that you have ample room to mount the indoor unit, the diagrams to the right show different types of mounting plates along with the following dimensions:

- Height & Width of mounting plate
- Height & Width of indoor unit relative to plate
- Recommended position of wall hole
- Relative distances between screw/mounting holes
- Unit can be configured with either a left or right rear wall hole, depending on your application.

Correct orientation of Mounting Plate

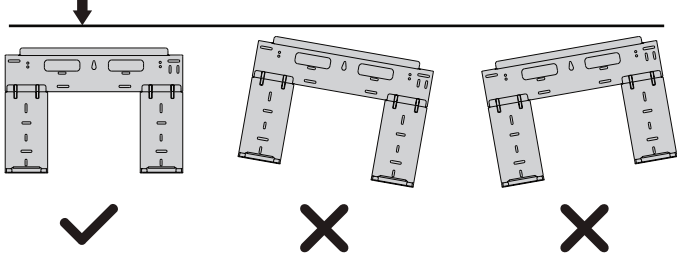

NOTE: Use a level in order to ensure your mounting plate is mounted to the wall with the correct orientation shown above.

Correct Angle to Drill Wall Hole

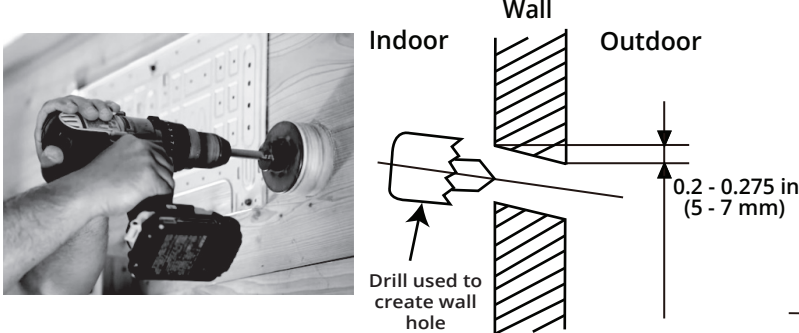

Fig. 4.3

Wall Hole Sleeve Installation



Fig. 4.4

NOTE REGARDING WALL STUDS

1. Wall Mounting Bracket should be installed on studs.
2. Standard US Studs are 16" on-center.
3. 16" on-center correlates with the holds marked "US" on the metal bracket.

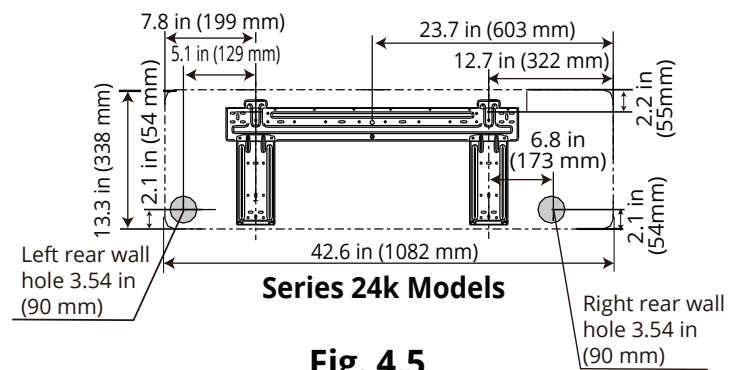
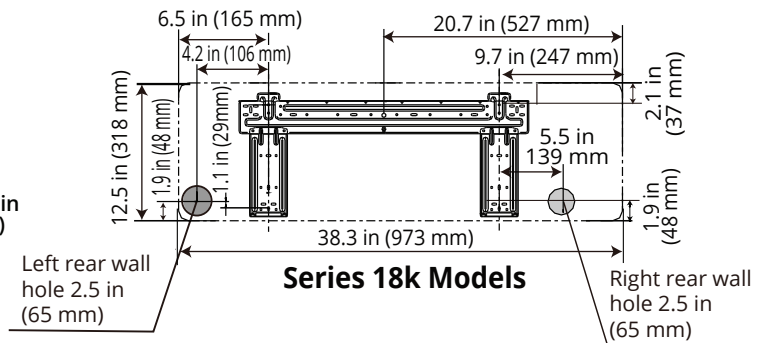
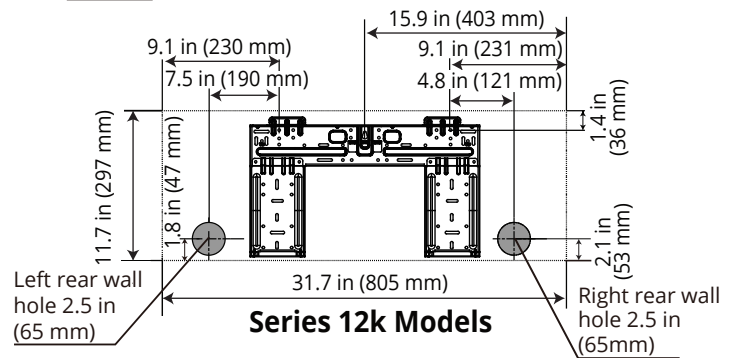
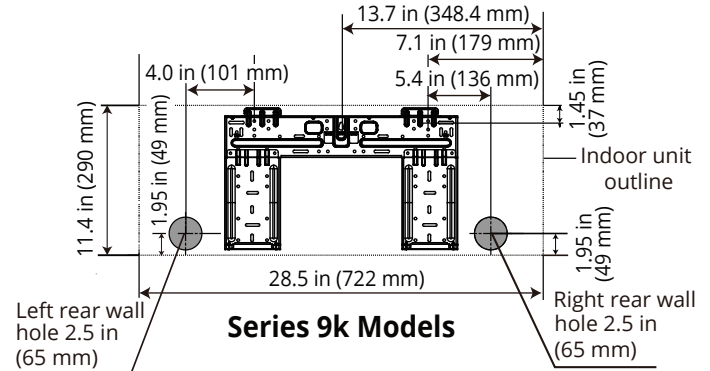

Fig. 4.5

Step 4: Prepare indoor unit refrigerant piping

The piping of the indoor unit is attached to the back of the unit towards the bottom. It will be covered with insulation, and there will also be a drain pipe with these. This piping will need to be bent and prepared before it can be fed through the wall hole.

NOTE: Refrigerant piping should exit the indoor unit from the right-hand side (Refer to Fig 4.6)

1. Based on the position of the wall hole, relative to the mounting plate, determine the necessary angle the piping will need to be bent to pass through the wall hole when the unit is mounted to the bracket.
2. Grip the refrigerant piping at the base of the bend. Then, slowly, and with even pressure, bend the piping away from the back of the unit roughly 90 degrees. The piping should be sticking straight out from behind the unit once completed (Refer to Fig 4.6).

! CAUTION

Be extremely careful not to dent or damage the piping while bending it away from the unit, as this could negatively affect the performance.

Fig. 4.6

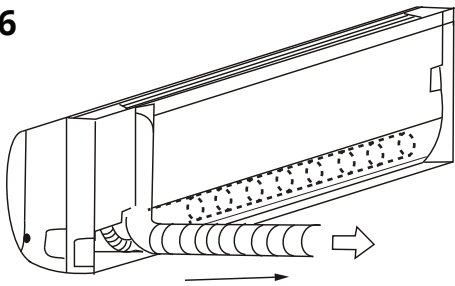

3. Now, you will need to lightly tape the refrigerant piping and drain pipe together in a bundle, using electrical tape, making sure that the drain pipe is at the bottom. **DO NOT** tape the ends of the piping (connectors). Refer to Fig 4.7 and the image below for the correct orientation of the piping when taping.

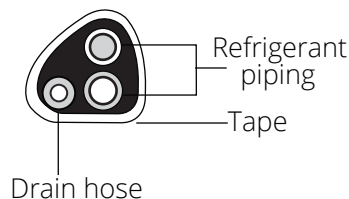

Fig. 4.7

DRAIN HOSE MUST BE ON BOTTOM

The drain hose must be placed at the bottom of the bundle. If it is not, it could cause the drain pan to overflow, which could lead to fire or water damage.

Step 5: Mount the Indoor Unit

In the following steps the indoor unit will now be mounted to the wall bracket and the piping and wires will be fed through the wall hole.

1. Double-check that the ends of the refrigerant pipes are sealed (screw on caps are still in place) to prevent any dirt or foreign material from entering the pipes.
2. Feed the MC Cable/signal wire (should be protected by conduit) through the wall hole.
3. Carefully lift the indoor air handler, and slowly feed the taped bundle of refrigerant pipes and drain hose through the wall hole, as you position it to mount to the wall bracket.

NOTE: Positioning the air handler onto the wall bracket, while feeding the piping through the wall hole, might be difficult. So, it may be necessary to seek the assistance of another person for this step.

4. Slightly lean the top of the air handler toward the wall and hook the top of the indoor unit on the upper hook of the wall mounting plate.
5. Check that the unit is hooked firmly on the mounting plate by applying slight pressure to the left and right-hand sides of the unit. The unit should not jiggle or shift.
6. Using even pressure, push down on the bottom half of the unit. Continue pushing down until the unit snaps onto the hooks along the bottom of the mounting plate.
7. Again, check that the unit is firmly mounted to the wall bracket by applying slight pressure to the left and right-hand sides of the unit.



UNIT IS ADJUSTABLE

Keep in mind that the hooks on the mounting plate are smaller than the holes on the back of the unit. If you find that there is not enough room to connect embedded pipes to the indoor unit, it can be adjusted left or right by 1.25-1.95 in (30-50 mm), depending on the model.



NOTE: Install the unit by following local codes and regulations. These may differ slightly depending on the region where the unit is being installed.

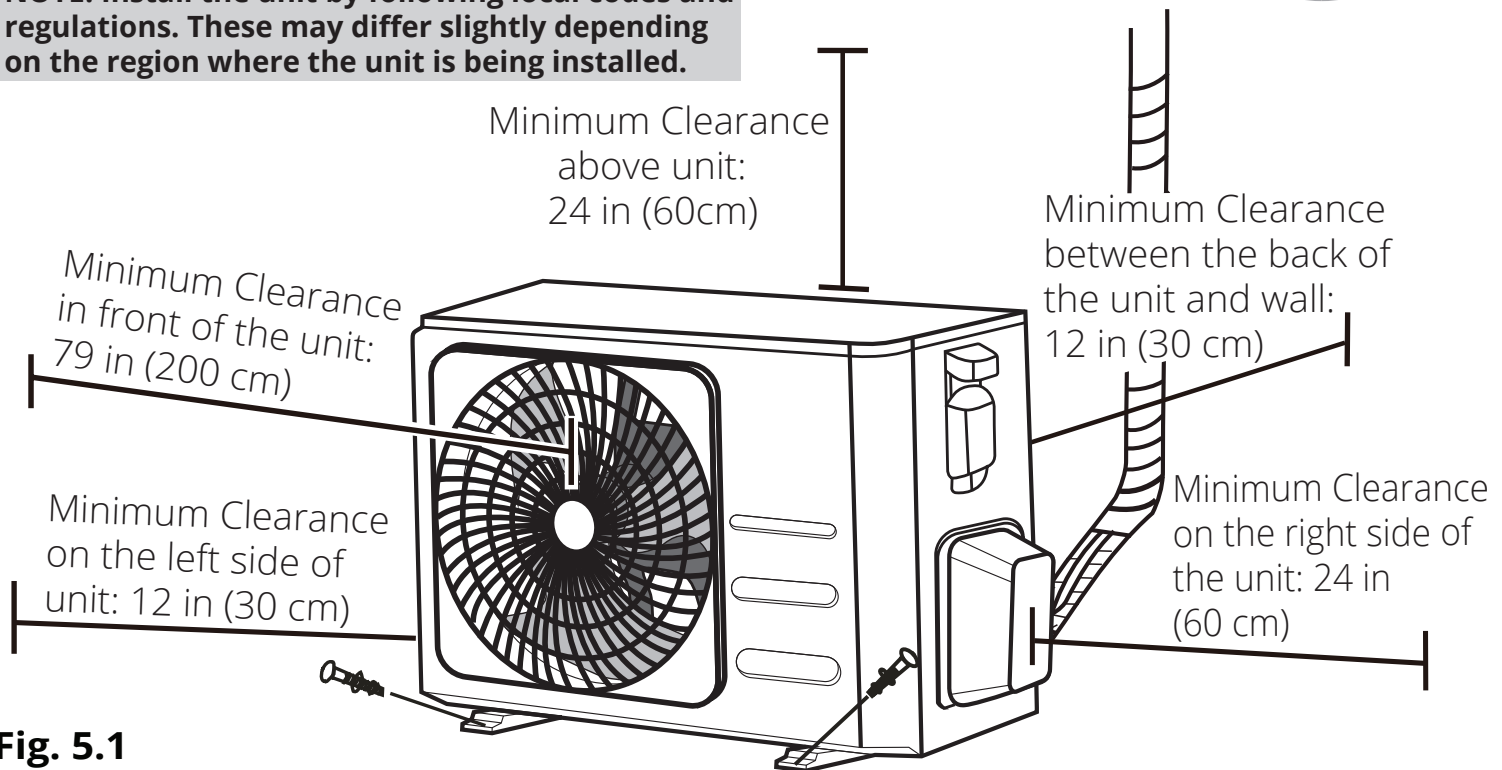

Fig. 5.1

Installation Instructions - Outdoor Unit

Step 1: Selecting an installation location

Before installing the outdoor unit, you must choose an appropriate location. Use the following guidelines to help you select an appropriate location.

Proper installation locations meet the following guidelines:

- ☑ Meets all spatial requirements shown in Installation Space Requirements (Fig. 5.1)
- ☑ Good air circulation and ventilation
- ☑ Firm and solid location that can support the unit and will not cause vibration
- ☑ Noise from the unit will not disturb others
- ☑ Protected from prolonged periods of exposure to direct sunlight or rain
- ☑ Where snowfall is anticipated, raise the unit above the base pad to prevent ice buildup and coil damage. Mount the unit in a position high enough to be above the average accumulated area snowfall. The minimum height must be at least 18 in (457.2 mm).

DO NOT install unit in the following locations:

- ⊘ Near an obstacle that will block air inlets and outlets
- ⊘ Near a public street, crowded areas, or where noise from the unit will disturb others
- ⊘ Near animals or plants that will be harmed by hot air discharge
- ⊘ Near any source of combustible gas
- ⊘ In a location that is exposed to large amounts of dust
- ⊘ In a location exposed to a excessive amounts of salty air
- ⊘ In a location that exposes the unit to large amounts of forced water

SPECIAL CONSIDERATIONS FOR EXTREME WEATHER

If the unit is exposed to heavy wind: Install unit so that air outlet fan is at a 90° angle to the direction of the wind. If needed, build a barrier in front of the unit to protect it from extremely heavy winds. Ensure the wind barrier does not block necessary air flow. See Fig. 5.2 and Fig. 5.3 below.

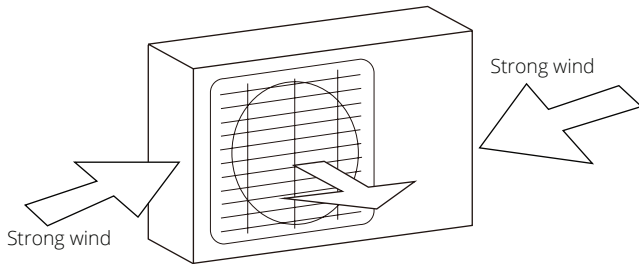

Fig. 5.2

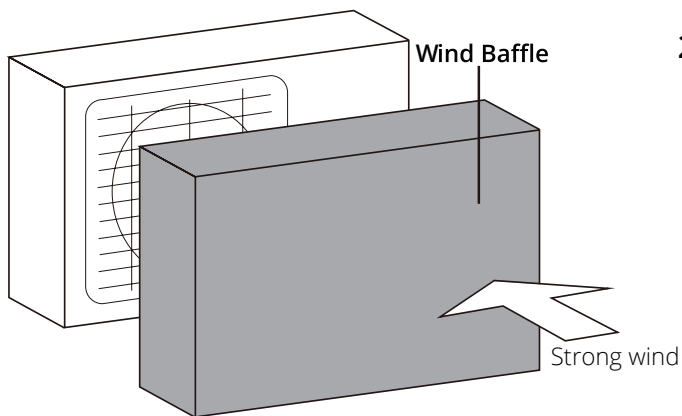

Fig. 5.3

If the unit is frequently exposed to heavy rain or snow:

Build a shelter above the unit to protect it from rain or snow. Be careful not to obstruct air flow around the unit.

If the unit is frequently exposed to salty air (seaside):

Use an outdoor unit that is specially designed to resist corrosion.

Step 2: Install drain joint

Heat pump units require a drain joint if the unit is elevated. Before bolting the outdoor unit in place, you must install the drain joint at the bottom of the unit. **NOTE:** there are two different types of drain joints depending on the type of outdoor unit.

If the drain joint comes with a rubber seal (see Fig. 5.4 - A), do the following:

1. Fit the rubber seal on the end of the drain joint that will connect to the outdoor unit.
2. Insert the drain joint into the hole in the base pan of the unit.
3. Rotate the drain joint 90° until it clicks in place facing the front of the unit.
4. Connect a drain hose extension (not included) to the drain joint to redirect water from the unit during heating mode.

If the drain joint does not come with a rubber seal (see Fig. 5.4 - B), do the following:

1. Insert the drain joint into the hole in the base pan of the unit. The drain joint will click in place.
2. Connect a drain hose extension (not included) to the drain joint to redirect water from the unit during heating mode.

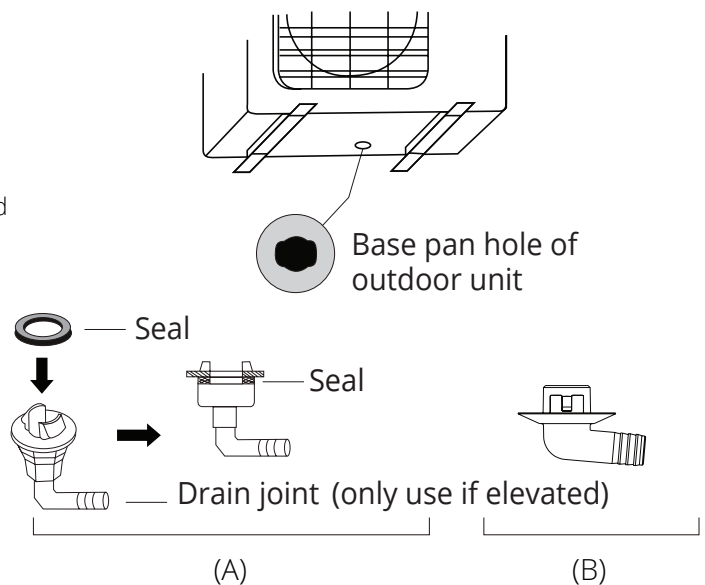

Fig. 5.4

! DRAINAGE IN COLD CLIMATES

In cold climates, make sure that the drain hose is as vertical as possible to ensure swift water drainage. If water drains too slowly, it can freeze in the hose and flood the unit.

Outdoor Unit Installation

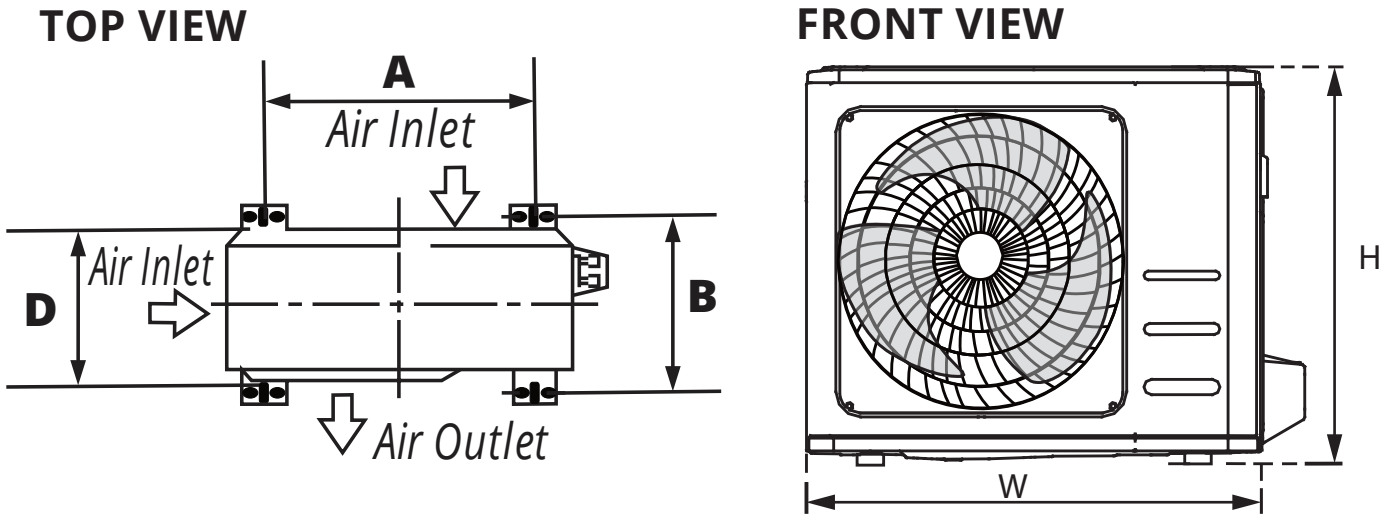

Fig. 5.5

UNIT MOUNTING DIMENSIONS

The following is a list of different outdoor unit sizes and the distance between their mounting feet. Prepare the installation base of the unit according to the dimensions in the table below, using the illustrations of the unit above (**Fig 5.5**) as a reference/guide to correspond with the table.

Capacity	Outdoor Unit Dimensions:	Mounting Dimensions:	
	Inches (Millimeters) Width (W) x Height (H) x Depth (D)	Width (A)	Depth (B)
9K	28.35 in x 19.49 in x 10.63 in (720 mm x 495 mm x 270 mm)	17.80 in (452 mm)	10.0 in (255 mm)
12K	28.35 in x 19.49 in x 10.63 in (720 mm x 495 mm x 270 mm)	17.80 in (452 mm)	10.0 in (255 mm)
18K	30.12 in x 21.85 in x 11.93 in (765 mm x 555 mm x 303 mm)	17.80 in (452 mm)	11.30 in (286 mm)
24K	35.04 in x 26.50 in x 13.46 in (890 mm x 673 mm x 342 mm)	26.10 in (663 mm)	13.90 in (354 mm)

If you are installing the outdoor unit on the ground, or a concrete mounting platform, use the following steps:

1. Mark the positions for four expansion bolts based on dimensions in the Unit Mounting Dimensions chart and illustrations above.
2. Pre-drill holes for expansion bolts.
3. Clean concrete dust away from holes.
4. Place a nut on the end of each expansion bolt.
5. Hammer expansion bolts into the pre-drilled holes.

6. Remove the nuts from expansion bolts, and place outdoor unit on bolts.
7. Put a washer on each of the expansion bolts, then reinstall the the nuts.
8. Using a wrench, tighten each nut until snug.

WARNING

WHEN DRILLING INTO CONCRETE, EYE PROTECTION IS RECOMMENDED AT ALL TIMES.

If you are installing the unit on a wall-mounted bracket, follow these steps:

! CAUTION

Before installing a wall-mounted unit, make sure that the wall is made of solid brick, concrete, or a similarly strong material. The wall must be able to support at least 4 times the weight of the unit.

1. Mark the position of bracket holes based on dimensions in the Unit Mounting Dimensions chart.
2. Pre-drill the holes for the expansion bolts.
3. Clean dust and debris away from holes.
4. Place a washer and nut on the end of each expansion bolt.
5. Thread expansion bolts through holes in mounting brackets, put mounting brackets in position, and hammer expansion bolts into the wall.
6. Check that the mounting brackets are level.
7. Carefully lift unit and place its mounting feet on the brackets.
8. Bolt the unit firmly to the brackets.

TO REDUCE VIBRATION OF WALL-MOUNTED UNIT

If allowed, you can install the wall-mounted unit with rubber gaskets to reduce vibration and noise.

Step 1: Prepare exterior wall hole

Before the refrigerant piping can be installed and connected to the indoor and outdoor units, some additional steps are required to prepare the exterior.

1. Install finishing ring/cap to exterior portion of the wall hole.



2. Place your hand on the underside of the piping coming through the exterior wall hole (from indoor unit), close to the wall. With your other hand, using even pressure, carefully bend the piping downward toward the wall, being mindful not to damage or dent the piping in the process.



! CAUTION

Be extremely careful not to dent or damage the piping while bending it down the exterior wall, as this could negatively affect the performance.

3. Pack the wall hole with the supplied Neoprene (or Spray Foam can be used) to seal the hole, filling any space that was not taken up by the refrigerant piping and lines.

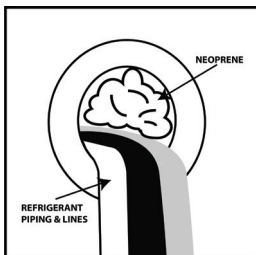

Step 2: Unwind Fast Connect® Line Set to necessary length

1. Use your hands to slowly unwind the copper piping of one end of the Fast Connect® Line Set. The end you unwind will connect to the indoor unit piping. Only unwind as much as necessary for your application, and allow any excess to remain coiled (Refer to **Fig. 6.1**).



MINIMUM BEND RADIUS

When bending connective refrigerant piping, it needs to have a minimum bend radius of 4 inches (Refer to Fig 6.1).

! CAUTION

If the pipe is repeatedly bent or extended, it will become hard and difficult to manipulate. Avoid bending or extending the pipe more than 3 times, or excessively, as it could break.

Fig. 6.1

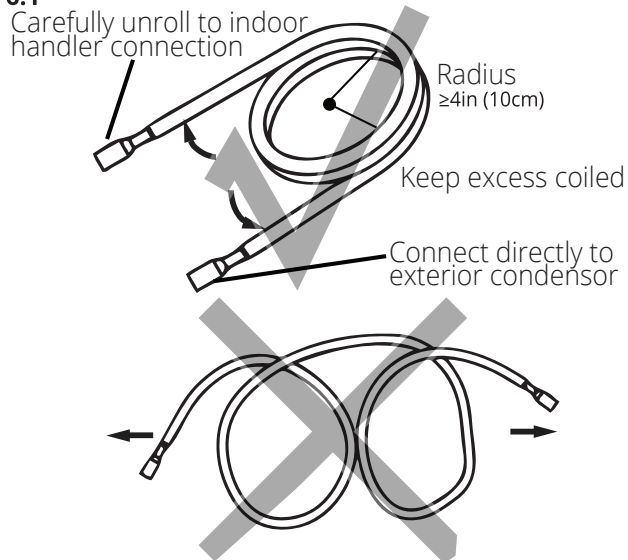

NOTE:

Keep excess refrigerant hose coiled. Wrap with protective tape and store behind the condenser in a horizontal position (flat with the ground).

Refrigerant Piping Connection

Step 3: Connect Line Set to Indoor Unit

3.1 Tools needed

NOTE: Depending on the capacity rating of your unit, (9K, 12K, 18K, 24K) the wrench sizes needed will vary, refer to the table below (the unit uses metric sizes, the standard sizes listed are approximations). Based on the availability of wrenches in some of the sizes needed, the recommended method is to use crescent (adjustable-type) wrenches that can be adjusted to fit the size each step requires.

- Opened-ended wrench sizes needed (1x of each of these)

9K & 12K & 18K	24K
3/4" / 19 mm	3/4" / 19 mm
7/8" / 22 mm	15/16" / 24 mm
15/16" / 24 mm	1" / 26 mm
1" / 26 mm	1-1/8" / 29 mm
	1-1/4" / 31 mm

Or 2x Crescent (adjustable-type) Wrenches

- 1x HVAC Torque Wrench (if available)
- 1x Allen key, 5 mm
- 1x Phillips-head screwdriver
- 1x leak-detection spray or a soapy water solution (liquid detergent/mix, applied by brush or spray bottle)

3.2 IMPORTANT INFORMATION

PLEASE READ FULLY BEFORE PROCEEDING TO NEXT STEP

- Follow the detailed instructions for connecting the refrigerant pipes to the indoor unit and outdoor unit. We can only provide a warranty if the lines are installed correctly as described in the instructions.
- **DO NOT** remove the sealing caps and stoppers until immediately before you install the lines.
- To prevent leaks, ensure that the quick-release screw connections are absolutely free of dirt. Moisture or foreign bodies will adversely affect the function of the quick-release connectors, leading to a risk of refrigerant loss (not covered by the warranty).
- Only install refrigerant lines outdoors in dry weather.
- The refrigerant lines must not be plastered over after they are installed.
- Always wear work gloves and goggles and use caution when handling refrigerant. Please make sure that refrigerant is never allowed to enter the environment. Improper handling of refrigerant may be harmful to your health.
- **DO NOT** smoke during the installation work.
- The equipment must never be operated without the refrigerant lines connected, otherwise the equipment will be damaged immediately.
- The screw connections may only be tightened using the appropriate open-ended or crescent (adjustable-type) wrench.

Refrigerant Pipe Connectors (both ends):

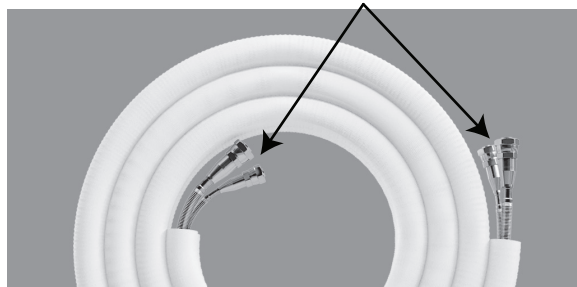

If the screw connections are tightened with too little torque, they will leak. If they are tightened with too much torque, the screw connections may suffer damage, which could also cause them to leak. Please refer to the torque requirements section for more information. If you are not confident about connecting the refrigerant line connectors yourself, it is imperative that you contact customer service or a professional HVAC technician.

IMPORTANT:

The line sets are designed to only be installed once. The seal within the line set cannot be guaranteed if they are installed more than once. This will void the warranty. They also contain a compression fitting to seal and do not require a thread sealant (teflon tape, etc.). Using a sealant may actually cause the connection to leak over time.

3.3 Connecting the Fast Connect® Line Set to the piping from indoor unit

1. Do not remove the plastic seals of the piping coming from the indoor unit, or the appropriate line set connector, until immediately before you connect them. The plastic seals on each of the connectors should be color-coded to match the seals of the corresponding pipes they are to be connected to.
2. Align the refrigerant pipes correctly, making sure the dimensions of the connecting refrigerant pipe match. Unscrew the seals and place the screw connector of the line set pipe just onto the threads of the piping from the indoor unit, and tighten the first few threads by hand.



IMPORTANT:

Before you continue, it is essential that you read the following instructions fully and carefully.

! TORQUE REQUIREMENTS

1. Excessive torque can break the nut or damage the refrigerant piping. You must not exceed the torque requirements shown in the table below.
2. You can find the coupling size and torque rating by looking for the stamped part number on the connector and using it to find the corresponding torque rating in the table below.
3. Note there may be differences in Torque Wrenches (i.e. automotive torque wrench versus an HVAC torque wrench) and that a socket-style wrench cannot be used here.

NOTE: Torque ratings in the table below are to be used if you have access to an HVAC torque wrench. These are available for purchase from online retailers. However, it is possible to complete installation of refrigerant line sets with conventional open-ended/crescent wrenches. It is imperative, however, that you not over-tighten the connector, and that once the lines have been fully connected, you follow the steps to check for leaks. If you do not feel comfortable attempting this, please contact a qualified HVAC technician.

3. Using the image below as a guide, and the steps outlined in this paragraph, you will now tighten the nuts of the screw connectors of the Fast Connect™ Line Set to the indoor unit. Using two appropriate sized open-ended wrenches (depending on the dimensions of the connector) or adjustable crescent wrenches, place one of the wrenches on the nut marked "1", and the other wrench on the nut marked "2", as shown in the image below. Now, turn the wrench marked "2" in the direction of the rotational arrows, as shown, while holding the other wrench in place. Continue to tighten the connector until snug.

NOTE: work quickly and make sure the screw connectors do not become crooked as you tighten them.

***If an HVAC torque wrench is available:** Once the connector is snug, using the torque wrench, tighten the connector to the specified torque rating, listed in the table above (based on pipe size).

***If an HVAC torque wrench is NOT available:** Using the two wrenches you used to tighten the connector, once the connector is snug, turn the wrench slightly beyond that point to torque the connector, but do not overtighten it.

Stamp (on connector)	Coupling Size inch (millimeter)	Maximum Tightening Torque lb-ft (N-m)
FA06	3/8 in (9.5 mm)	18-20 lb/ft (24.4-27.1 Nm)
FA09	1/2 in (12.7 mm)	30-35 lb/ft (40.6-47.4 Nm)
FA12	3/4 in (19.1 mm)	45-50 lb/ft (61.0-67.7 Nm)
FA16	1 in (25.4 mm)	60-65 lb/ft (81.3-88.1 Nm)

4. Repeat the same process for the second line.

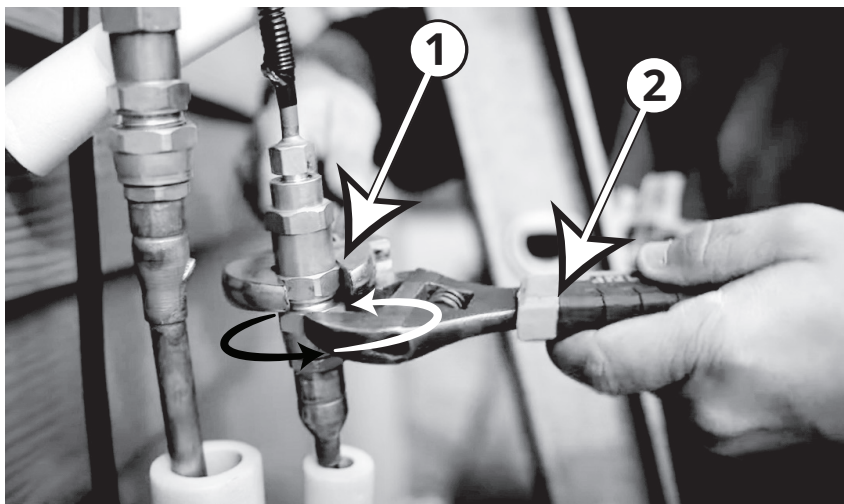

! CAUTION

For your safety, always wear goggles and work gloves when connecting the pipes.

Step 4: Connect Line Set to the Outdoor Unit

1. First remove the water tray on the outdoor unit as shown in the illustration.

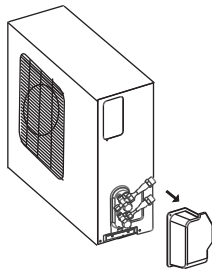

2. Do not remove the plastic seals from the outdoor unit piping connectors and corresponding refrigerant pipes (line set to be attached) until immediately before you connect them.

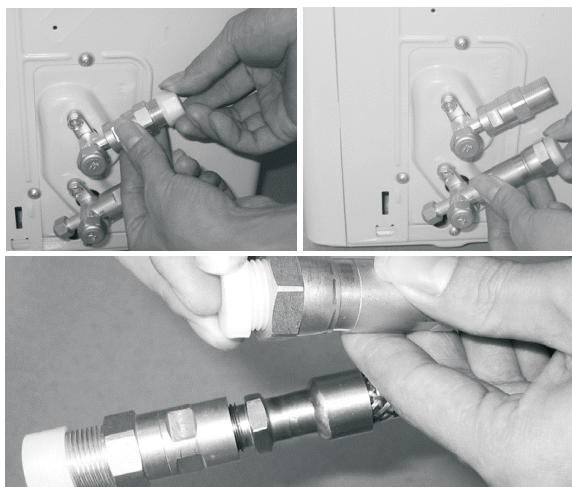

NOTE: Ensure the adapters attached to the outdoor valves have been tightened properly before attempting to connect the line set.

3. Align the refrigerant pipes so they line up with the corresponding valves and have enough slack. **NOTE: The refrigerant pipes must be connected to the valves with as little stress as possible.** Unscrew the plastic seals and place the screw connector of the refrigerant line just onto the threads of the outdoor unit, tightening the first few threads by hand.

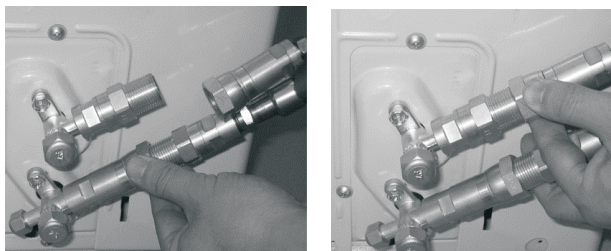

IMPORTANT:

Before you continue, it is essential that you read the following instructions carefully.

4. Using the first image below as a guide, starting with the bottom screw connector, you will now tighten the line set to the outdoor unit. Using two appropriate sized open-ended wrenches (depending on the dimensions of the connector), or adjustable crescent wrenches, place one of the wrenches on the nut marked "1", and the other wrench on the nut marked "2." Now, turn the wrench on nut "2" in the direction of the rotational arrow, while holding the other wrench in place, as seen in the first image below. Continue to tighten the connector until snug. **NOTE: work quickly and make sure the screw connectors do not become crooked as you tighten them.**

***If an HVAC torque wrench is available:** Once the connector is snug, using the torque wrench, tighten the connector to the specified torque rating, listed in the table on the next page (based on the pipe size).

***If an HVAC torque wrench is NOT available:** Using the two wrenches you used to tighten the connector, once the connector is snug, then turn the wrench slightly beyond that point to torque the connector, but do not overtighten it.

5. Repeat the same process for the top screw connector, using the second image below as a guide.

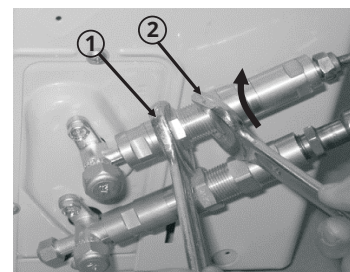
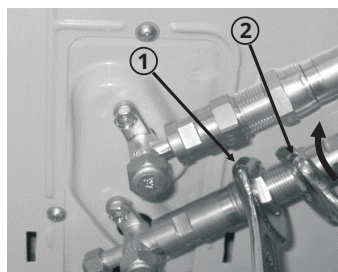

! IMPORTANT

The coupling of the outdoor unit uses tapping rings, if you disconnect and reconnect the refrigerant pipes, it could cause it to leak. This will also void the warranty.

TORQUE REQUIREMENTS

1. Excessive torque can break the nut or damage the refrigerant piping. You must not exceed the torque requirements shown in the table below.
2. You can find the coupling size and torque rating by looking for the stamped part number on the connector and using it to find the corresponding torque rating in the table below.
3. Note there may be differences in Torque Wrenches (i.e. automotive torque wrench versus an HVAC torque wrench) and that a socket-style wrench cannot be used here.

NOTE: Torque ratings in the table below are to be used if you have access to an HVAC torque wrench. These are available for purchase from online retailers. However, it is possible to complete installation of refrigerant line sets with conventional open-ended/crescent wrenches. It is imperative, however, that you not over tighten the connector, and that once the lines have been fully connected, you follow the steps to check for leaks. If you do not feel comfortable attempting this, please contact a qualified HVAC technician.

Stamp (on connector)	Coupling Size inch (millimeter)	Maximum Tightening Torque lb-ft (N-m)
FA06	3/8 in (9.5 mm)	18-20 lb/ft (24.4-27.1 Nm)
FA09	1/2 in (12.7 mm)	30-35 lb/ft (40.6-47.4 Nm)
FA12	3/4 in (19.1 mm)	45-50 lb/ft (61.0-67.7 Nm)
FA16	1 in (25.4 mm)	60-65 lb/ft (81.3-88.1 Nm)

Refrigerant Piping Connection

Step 5: Opening the refrigerant valves of the outdoor unit

1. Using the images below as a guide, remove the cover on the top valve, using a 19 mm open-ended wrench or a crescent (adjustable-type) wrench. Then, insert a 5 mm Allen key and open the valve by turning it counter-clockwise as far as it will go. **DO NOT force it.** The valve is now open. Screw the cover back onto the top valve and tighten it well to ensure that it is properly sealed.
2. Using the images below as a guide, repeat the same process for the bottom valve. Remove the cover on the bottom valve, using a 19 mm open-ended wrench or a crescent (adjustable-type) wrench. Then, insert a 5 mm Allen key and open the valve by turning it counter-clockwise as far as it will go. **DO NOT force it.** Screw the cover back onto the bottom valve and tighten it well to ensure that it is properly sealed.

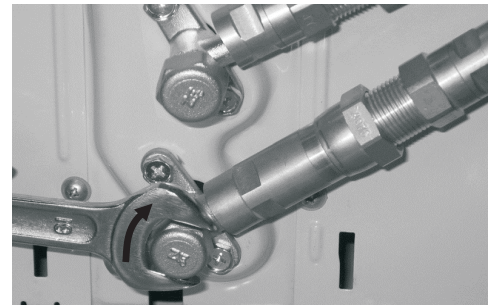
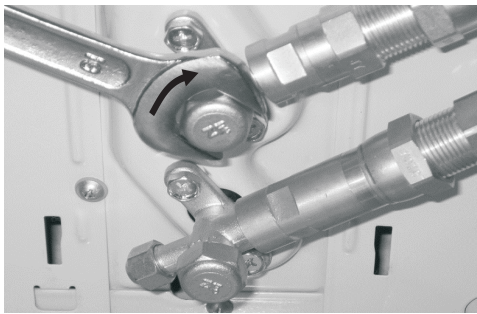
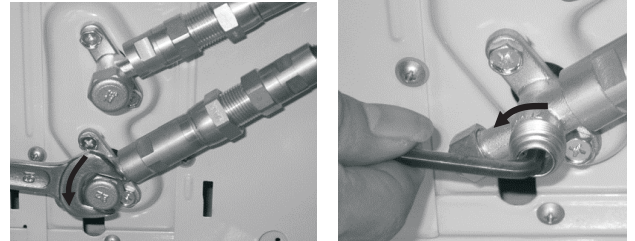
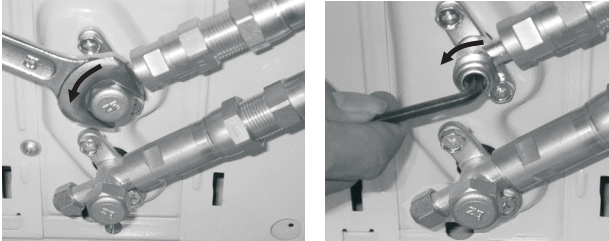

IMPORTANT:

The conical ring on the valve and the seat within the caps have an important function of sealing the valve. Ensure that you do not damage the cone and you keep the cap free of dust and dirt while performing these steps.

! CAUTION

If the valves are not fully opened, it could cause the system to malfunction and suffer damage.

3. After completing steps 1 and 2, you will now need to check all of the piping connections (at indoor unit and outdoor unit) for leaks. You can do this by using leak detection spray or applying a soapy water solution (liquid detergent/water mixture) to the connection via a spray bottle or brush. If any bubbles begin to form, that indicates there is a leak, and the connection needs to be re-tightened. Tighten the connection and recheck it for leaks. Refer to **Electrical and Gas Leaks Checks** section of this manual for more information.



IMPORTANT:

You will be asked to check for leaks at the piping connections multiple times throughout the following steps of the installation, because the pressures within the lines will change once the unit is turned on and this could reveal leaks not present during the initial check. These are imperative to make sure your connections are not allowing refrigerant to escape the system. When checking for leaks, if any bubbles form, it indicates the system has a leak and the screw connector needs to be re-tightened. For more information about checking for leaks, please refer to the Electrical and Gas Leak Checks section of the manual.

Step 6: Connect Drain Pipe

In this step you will connect the drain hose extension to the drain hose exiting from the indoor unit that is within the piping bundle you wrapped in the previous steps.

1. Securely connect the drain hose extension to the drain piping from the indoor unit.

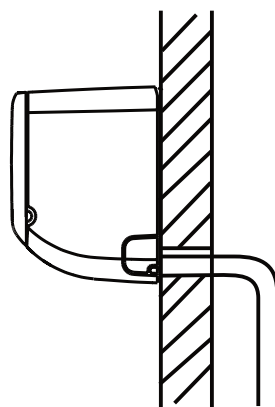

Fig. 6.2a

Make sure there are **NO** kinks or dents in the hose to ensure proper drainage.

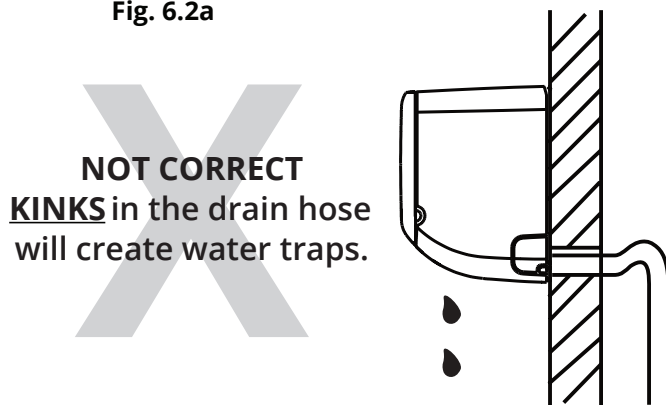

Fig. 6.2b

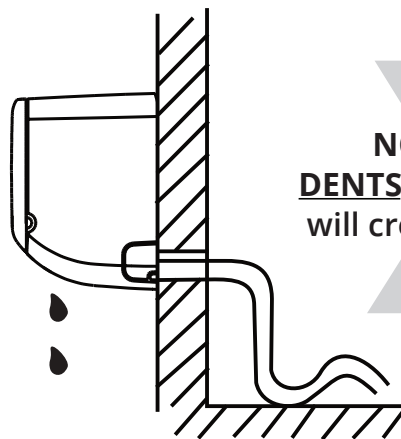

Fig. 6.2c

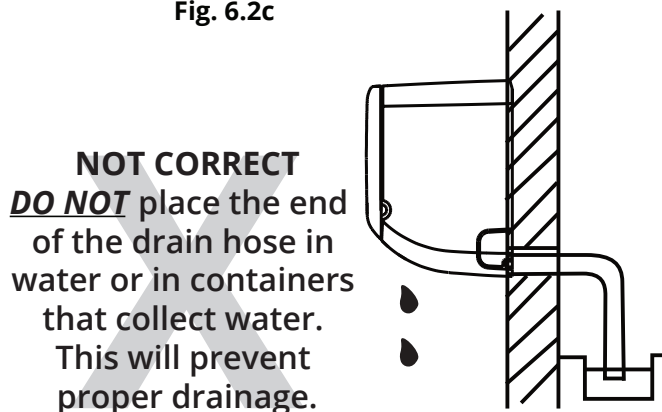

Fig. 6.2d

2. Using example **Fig. 6.2a** as a guide, make sure your drain pipe is run in a similar manner. The other examples in **Fig 6.2** represent things you should avoid when installing your drain pipe.
3. Remove the air filter from the indoor unit and pour a small amount of water into the drain pan to ensure that the water exits the bottom of the unit and flows through the drain and drain pipe smoothly.

NOTE ON DRAIN HOSE PLACEMENT

! CAUTION

Make sure to arrange the drain hose correctly according to Fig. 6.2a.

- ⊘ **DO NOT** kink the drain hose.
- ⊘ **DO NOT** create a water trap.
- ⊘ **DO NOT** put the end of drain hose in water or a container that will collect water.

ENSURE UNUSED DRAIN HOLE IS PLUGGED

To prevent unwanted leaks, you must plug the unused drain hole with the rubber plug provided.

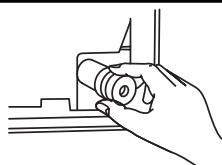

Refrigerant Piping Connection

Step 7: Wrap piping connections

In this step you will insulate the exposed line connections coming from the indoor air handler with the supplied sound deadening pads and insulation. Then wrap the line set from the outdoor unit to the wall hole with the supplied Non-Adhesive U.V. Tape.

IMPORTANT

Do not complete these steps until all of the refrigerant piping connections have been checked for leaks.

1. Wrap the connectors at the indoor air handler tightly with the supplied sound deadening pads.



2. Now, place the supplied insulation material over the connectors and exposed refrigerant piping

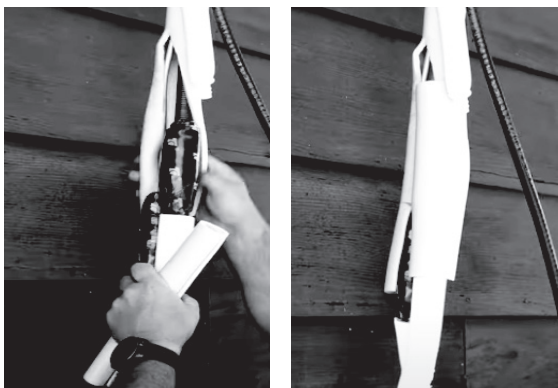

3. Now, starting at the outdoor condenser and working your way up to the wall hole, you will wrap the exposed line set and drain hose together tightly using the supplied Non-adhesive U.V. tape. The drain pipe will need to be at the bottom of the bundle (**Refer to Fig. 6.3 and the image below**). **DO NOT wrap the end of the drain hose**

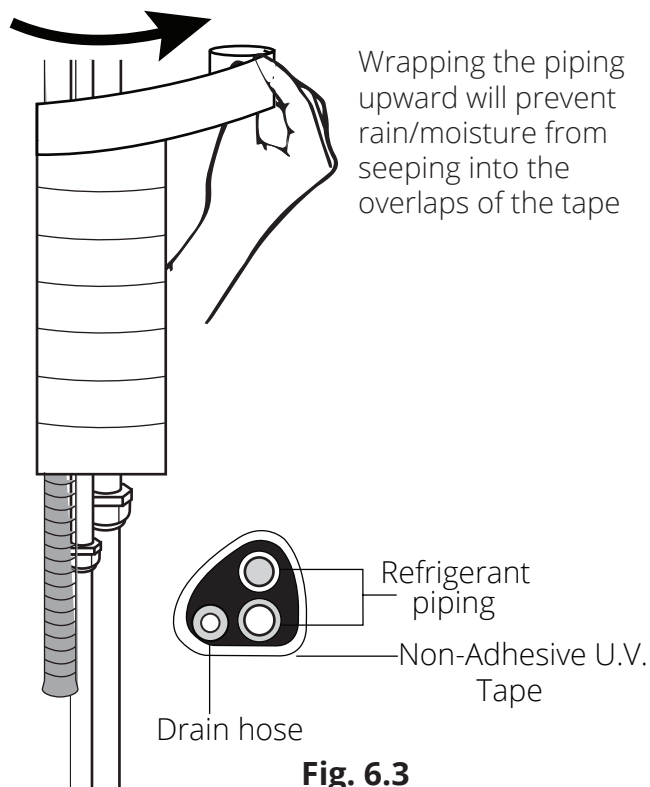

If you would like the exterior piping on the side of your home to have a sleeker, more attractive look and add some extra protection in the process, you can purchase a **MRCOOL LineGuard® Line Set Cover**. This will encase your refrigerant piping and lines, protecting them from harsh weather conditions and sun exposure, which will extend the life of your system. These covers are available in various sizes to fit your particular application.



Refrigerant Piping Connection

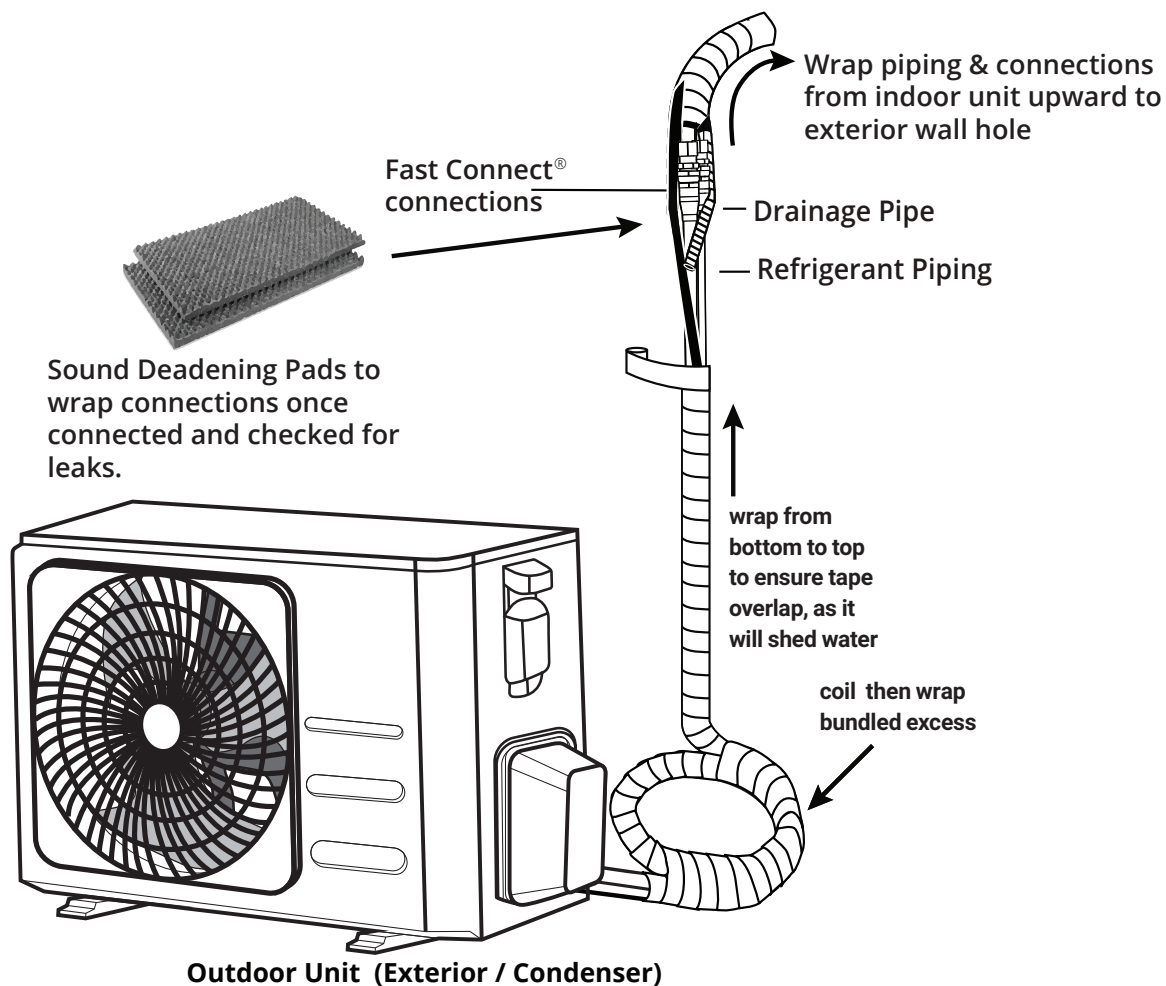

BEFORE PERFORMING ELECTRICAL WORK, READ THESE REGULATIONS

1. All wiring must comply with local and national electrical codes.
2. All electrical connections must be made according to the **Electrical Connection Diagram** located on the panels of both the indoor and outdoor units.
3. If there is a serious safety issue with the power supply, stop work immediately. Explain your reasoning to the client, and refuse to install the unit until the safety issue is properly resolved.
4. Power voltage should be within 90-110% of rated voltage. Insufficient power supply can cause malfunction, electrical shock, or fire.
5. If connecting power to fixed wiring, a surge protector and main power switch should be installed.
6. A qualified technician must use an approved circuit breaker or switch that disconnects all poles and has a contact separation of at least 1/8 in (3mm).
7. Only connect the unit to an individual branch circuit outlet. Do not connect another appliance to the same circuit as the unit.
8. Make sure to properly ground the unit.
9. Every wire must be firmly connected. Loose wiring can cause the terminal to overheat, resulting in malfunction and possible fire.
10. Do not allow wires to touch or rest against the refrigerant tubing, compressor, or any other moving part within the unit.
11. If the unit has an auxiliary electric heater, it must be installed at least 40 in (1 meter) away from combustible materials.
12. To avoid getting an electric shock, never touch the electrical components right after the power supply has been turned off. After turning off the power, always wait at least 10 minutes before you touch the electrical components.

Connect the DIYPRO™ Cable/signal wire and power cable

The outside unit's terminal block is protected by an electrical wiring cover on the side of the unit. A comprehensive wiring diagram is printed on the inside of the wiring cover.

! WARNING

ALL WIRING MUST BE INSTALLED BY A LICENSED ELECTRICIAN AND COMPLY WITH LOCAL, STATE, AND NATIONAL ELECTRICAL CODES.

BEFORE PERFORMING ANY ELECTRICAL WORK, TURN OFF ALL POWER TO THE SYSTEM.

Note that wire colors of this series / model may differ from previous models, other series and general conventions. All wiring must be performed in accordance with the wiring diagrams shown in Fig. 7.1 and demonstrated in the images below.

WIRE CONNECTING DIAGRAM (9K & 12K Units)

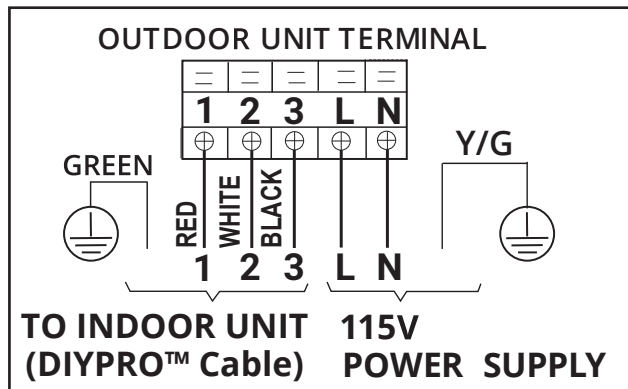

WIRE CONNECTING DIAGRAM (All Other Units)

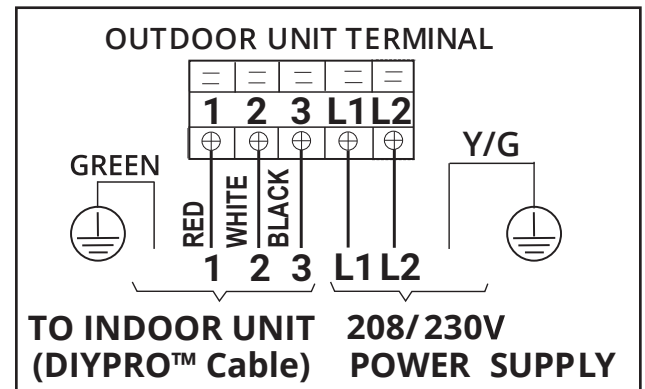

Fig. 7.1

! WARNING

DO NOT MIX UP LIVE AND NULL WIRES

This is dangerous and can cause the air conditioning unit to malfunction. Make sure you clearly distinguish the Live ("L") Wires from the other wires.

All wiring must be performed in accordance with the wiring diagrams shown in Fig. 7.1 and demonstrated in the images shown here.

! WIRES AND TERMINALS ARE NUMBERED TO CORRESPOND WITH ONE ANOTHER AS SHOWN BELOW.

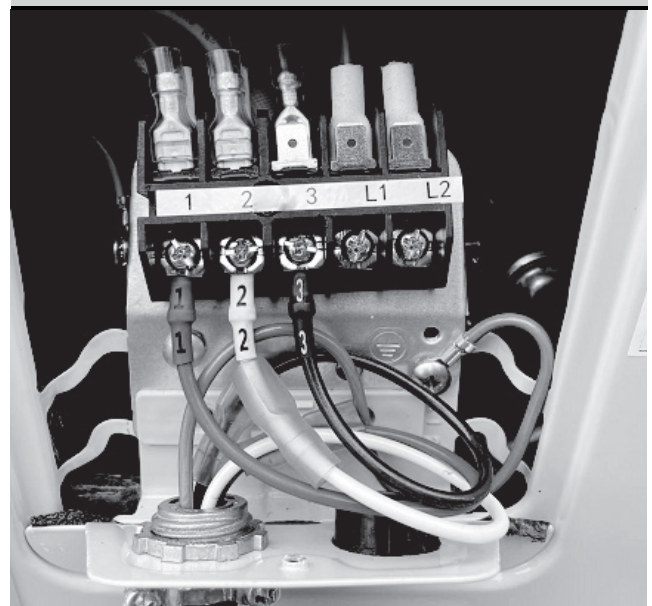

Electrical Connections

1. Remove the 3 screws from the electrical wiring cover from the outdoor condenser, as shown in the image below and **Fig. 7.2**, and remove it.

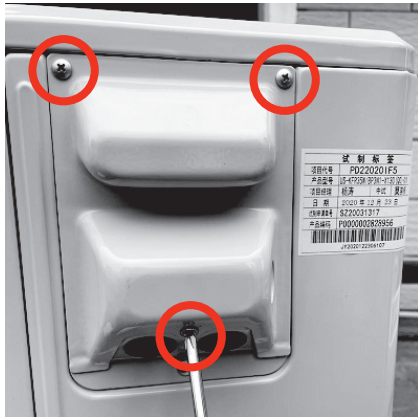

2. Remove the retaining nut from the end of the DIYPRO™ Cable that you fed through the wall hole earlier in the installation, as shown in the image below.

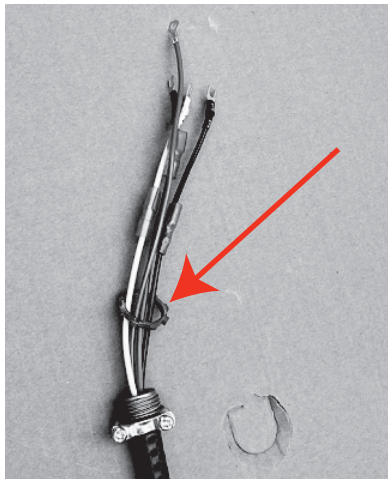

3. Now, pull the end of the DIYPRO™ Cable through the left hole of the outdoor condenser that was beneath the electrical cover you removed. Please refer to the image below.

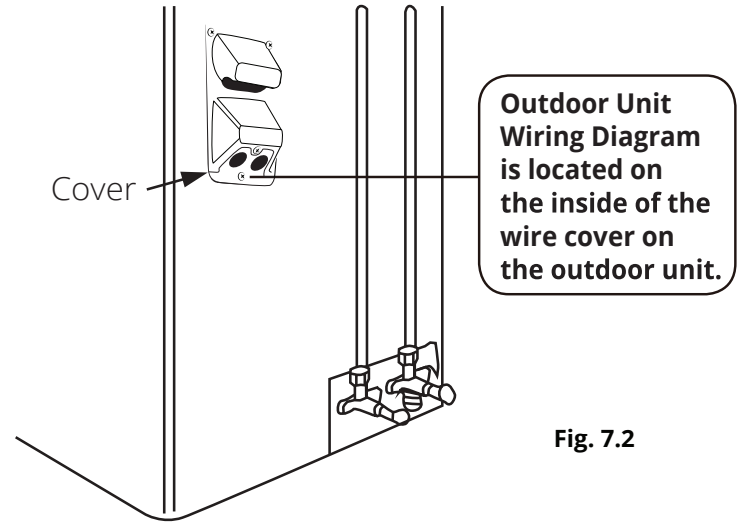
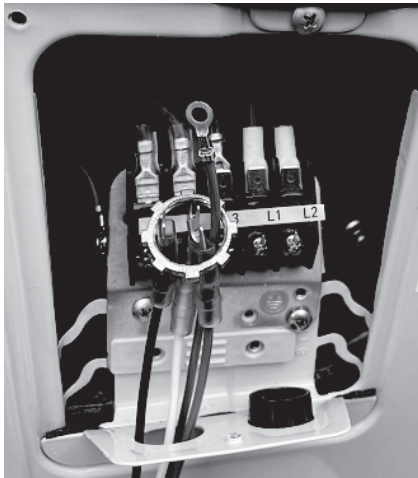

Fig. 7.2

SELECT THE CORRECT CABLE SIZE

The size of the power supply cable, signal cable, fuse, and switch needed is determined by the maximum current of the unit. The maximum current is indicated on the nameplate located on the side panel of the unit.

Cable Types:

- Indoor Power Cable (if applicable): H05VV-F or H05V2V2-F
- Outdoor Power Cable: H07RN-F or H05RN-F
- Signal Cable: H07RN-F

NOTE: In North America, please choose the right cable size according to the Minimum Circuit Ampacity (MCA) indicated on the nameplate of the unit and that is also in accordance with local electric codes and regulations.

Minimum Wire Gauge for Power Cables

Model Series	Appliance Amps (A)		AWG	
	MOP	MCA	Min.	Pref.
9K	30	20	14	12
12K	30	20	14	12
18K	25	15.5	14	12
24K	35	21	12	10



WARNING

ALL WIRING MUST BE INSTALLED STRICTLY IN ACCORDANCE WITH THE WIRING DIAGRAM LOCATED AS SHOWN IN FIG 7.2.

Electrical Connections

4. Now, secure the DIYPRO™ Cable to the outdoor condenser by pushing the threaded end of the cable into the hole and reinstalling the retaining nut on the end of the cable. Please refer to the images below.

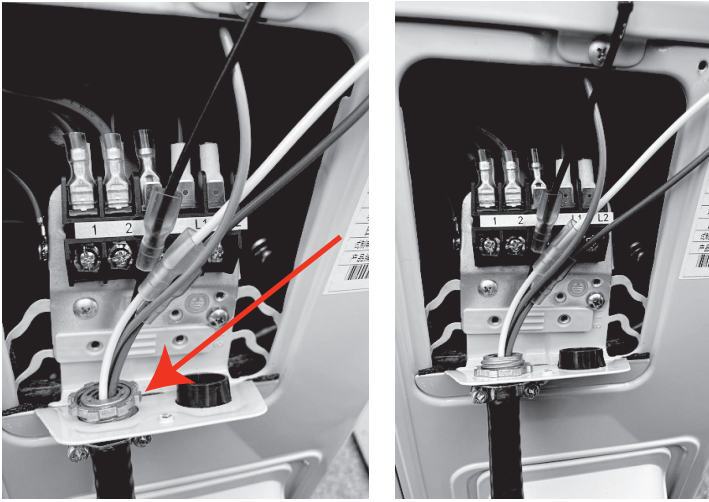

5. Then, you will connect the wires to the terminal block. Each wire should be numbered and correspond with a connection port on the terminal block. Match up each wire with the correct port, and firmly screw the u-lug of each wire to its corresponding terminal. Now, screw the ground wire into the bottom screw of the terminal block, as shown in the image below.

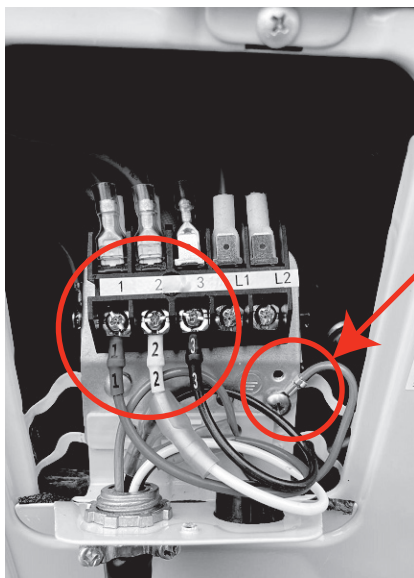

Ground wire Connection

6. Finally, reinstall the electrical wiring cover and secure it using the 3 screws you removed from it.



Minimum Cross-Sectional Area of Power and Signal Cables (For reference) (Not applicable for North America)

Rated Current of Appliance (A)	Nominal Cross-Sectional Area (mm ²)
> 3 and ≤ 6	0.75
> 6 and ≤ 10	1
> 10 and ≤ 16	1.5
> 16 and ≤ 25	2.5
> 25 and ≤ 32	4
> 32 and ≤ 40	6

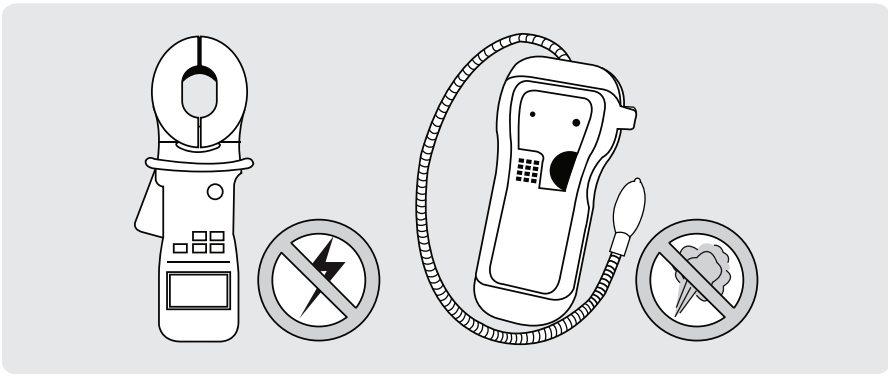

Electrical Safety Checks

After installation, confirm that all electrical wiring is installed in accordance with local and national regulations, and according to the Installation Manual.

BEFORE TEST RUN

Measure grounding resistance by visual detection and with a grounding resistance tester. Grounding resistance must be less than 0.1Ω .

NOTE: This may not be required for some locations in the US.

DURING TEST RUN

Check for Electrical Leakage.

During the Test Run, use an electroprobe and multimeter to perform a comprehensive electrical leakage test.

IF ELECTRICAL LEAKAGE IS DETECTED

If electrical leakage is detected, turn off the unit immediately and call a licensed electrician to find and resolve the cause of the leakage.

NOTE: This may not be required for some locations in the US.



WARNING – RISK OF ELECTRIC SHOCK

ALL WIRING MUST BE INSTALLED BY A LICENSED ELECTRICIAN AND COMPLY WITH LOCAL, STATE, AND NATIONAL ELECTRICAL CODES.

Gas Leak Checks

There are two different methods to check for gaseous leaks. Please refer to the illustration below for the areas to check for leaks.

Soap and Water Method

Using a soft brush or spray bottle, apply a soapy water solution to all of the pipe connection points of the indoor and outdoor units, watching to see if any bubbles form. The presence of bubbles indicates there is a leak.

Leak Detector Method

If using a leak detector, refer to the device's operation/instruction manual for proper usage instructions.

AFTER PERFORMING GAS LEAK CHECKS

After confirming that all the pipe connection points DO NOT leak, replace the valve cover on the outside unit and wrap and insulate the piping connections of the indoor unit.

Connection points of indoor unit to check for leaks

Connection points of outdoor unit to check for leaks

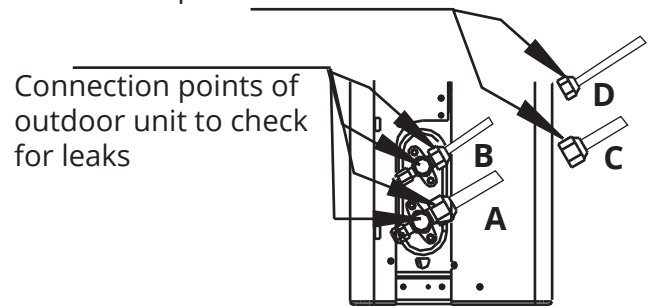

**A: Low pressure stop valve
B: High pressure stop valve
C & D: Indoor unit flare nuts**

Before Test Run

Only perform test run after you have completed the following steps:

- **Electrical Safety Checks** - Confirm that electrical system is safe and operating properly.
- **Gas Leak Checks** - Check all flare nut connections and confirm that the system is not leaking.
- Confirm that gas and liquid (high and low pressure) valves are fully open.

Test Run Instructions

You should perform the Test Run for at least 30 minutes.

1. Connect power to the unit.
2. Press the ON/OFF button on the remote controller to turn it on.
3. Press the MODE button to scroll through the following functions, one at a time:
 - **COOL** – Select lowest possible temperature
 - **HEAT** – Select highest possible temperature
4. Let each function run for 5 minutes, and perform the following checks:

List of Checks to Perform	PASS/FAIL	
No electrical leakage		
Unit is properly grounded		
All electrical terminals properly covered		
Indoor and outdoor units are solidly installed		
Wall Penetration Sleeve is packed airtight		
All pipe connection points do not leak	Outdoor (2):	Indoor (2):
Water drains properly from drain hose		
All piping is properly insulated		
Unit performs COOL function properly		
Unit performs HEAT function properly		
Indoor unit louvers rotate properly		
Indoor unit responds to remote control		

DOUBLE-CHECK PIPE CONNECTIONS

During operation, the pressure of the refrigerant circuit/piping will increase. This may reveal leaks that were not present during your initial leak check. Take time during the Test Run to double-check that all refrigerant pipe connection points do not have leaks. Refer to **Gas Leak Check** section for instructions.

5. After the Test Run is successfully complete, and you confirm all check points in List of Checks to Perform have PASSED, do the following:
 - a. Using remote control, return unit to normal operating temperature.
 - b. Using insulation tape, wrap the indoor refrigerant pipe connections that you left uncovered during the indoor unit installation process.

IF AMBIENT TEMPERATURE IS BELOW 60°F (16°C)

If the ambient temperature is below 60°F (16°C), the remote controller cannot be used to turn on the COOL function. In this instance, you will need to use the **MANUAL CONTROL BUTTON** to test the COOL function. Follow the steps below to access this function:

1. Lift the front panel of the indoor unit, and continue to raise it until it clicks into place and becomes self-supporting.
2. The **MANUAL CONTROL BUTTON** is located on the right-hand side of the unit (Refer to Fig 9.1). Press it 2 times to select the COOL function.
3. Perform Test Run as normal.

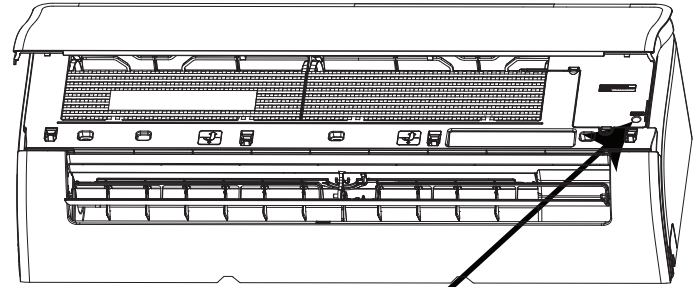

Manual Control Button

Fig. 9.1

The following events may occur during normal operation, and may not indicate a malfunction.

Symptom	Possible Cause
Unit does not turn on when pressing the ON/OFF button	The protection circuit will prevent the compressor from operating for roughly 3 minutes, after a sudden ON-OFF operation of the power supply, in order to prevent the unit from being overloaded.
The unit changes from COOL/HEAT mode to FAN mode	The unit may change its setting to prevent frost from forming on the unit. Once the temperature increases, the unit will start operating in the perviously selected mode.
	The set temperature has been reached, at which point the unit will turn off the compressor. The unit will continue operating when the temperature fluctuates again.
The indoor unit emits a white mist	In humid regions, a large temperature difference between the air with in the room and the air being emitted from the air conditioner can cause a white mist.
Both the indoor and outdoor units emit a white mist	When the unit restarts in HEAT mode after defrosting, a white mist may be emitted due to moisture generated from the defrosting process.
The indoor unit makes noises	A rushing air sound may occur as the louver resets its position
	A squeaking sound may occur after running the unit in HEAT mode due to expansion and contraction of the unit's plastic parts.
Both the indoor unit and outdoor unit make noises	Low hissing sound during operation: This is a normal sound caused by refrigerant gas flowing through both of the units.
	Low hissing sound when system starts, has just stopped running, or is defrosting: This is a normal sound that is caused by refrigerant gas stopping or changing direction.
	Squeaking sound: Normal expansion and contraction of plastic and metal parts due to changes in temperatures during operation can cause squeaking noises.
The outdoor unit makes noises	The unit will make different sounds based on its current operating mode.
Dust is emitted from either the indoor or outdoor unit	The unit may accumulate dust during extended periods of not being used. This will be emitted when the unit is turned on. This can be prevented by covering the unit during long periods of inactivity.
The unit emits a bad odor	The unit may absorb odors from the environment (such as furniture, cooking, cigarettes, etc.) which will be emitted from the unit during operations.
	The unit's filter have become moldy and need to be cleaned.
Outdoor unit fan does not operate	During operation, the fan speed is controlled to optimize product operation.
Operation is erratic, unpredictable, or unit is unresponsive	Interference from cell phone towers and remote boosters may cause the unit to malfunction. If this should occur, try the following: --Disconnect the power, then reconnect. --Press ON/OFF button on the remote control to restart the operation.

NOTE: If the problem is not resolved, please contact a qualified service professional. Be sure to inform them of the detailed malfunctions and unit model number.

Troubleshooting

Before you call to request service assistance, troubleshoot a problem by performing the following checks:

Symptom	Possible Causes	Solution
Poor Cooling Performance	Temperature setting may be higher than ambient room temperature	Lower temperature setting
	The heat exchanger on the indoor unit is dirty	Clean the affected heat exchanger
	The air filter is dirty	Remove the filter and clean it according to the instructions
	The air inlet or outlet of either unit is blocked	Turn the unit off , remove the obstruction and turn it back on
	Door and windows are open	Make sure that all doors and windows are closed while operating the unit
	Excessive heat is generated by sunlight	Close windows and curtains during periods of high heat or bright sunshine
	Too many sources of heat in the room (people, computers, electronics, etc.)	Reduce the amount of heat sources
	Low refrigerant due to leak or long-term use	Check for leaks, re-seal if necessary and top off the refrigerant
	SILENCE function is activated (optional function)	SILENCE function can lower product performance by reducing operating frequency. Turn off SILENCE function.
The unit is not working	Power failure	Wait for the power to be restored
	The power is turned off	Turn on the power
	The fuse burned out	Replace the fuse
	Remote control batteries are dead	Replace the batteries
	The unit's 3 minute overload protection function has been activated	Wait three minutes after restarting the unit
	Timer is activated	Turn timer off
The unit starts and stops frequently	There is excessive or not enough refrigerant in the system	Check for leaks and recharge the system with refrigerant
	Incompressible gas or moisture has entered the system	Evacuate and recharge the system with refrigerant
	The compressor is broken	Replace the compressor
	The voltage is too high or too low	Install a manostat to regulate the voltage
Poor heating performance	The outdoor temperature is extremely low	Use an auxiliary heating device
	Cold air is entering through the doors and windows	Make sure that all of the doors and windows are closed
	Low refrigerant due to a leak, or long-term use	Check for leaks, re-seal if necessary, and top off the refrigerant
Indicator lamps continue flashing	The unit may stop operation or continue to run safely. If the indicator lamps continue to flash or error codes appear, wait for about 10 minutes. The problem may resolve itself. If not, disconnect the power, then connect it again. Turn the unit on. If the problem persists, disconnect the power and contact your nearest customer service center. For more information on the error codes please refer to following pages.	
Error code appears and begins with these letters on the indoor unit display window: E(x), P(x), F(x), EH(xx), EL(xx), EC(xx), PH(xx), PL(xx),PC(xx)		

Troubleshooting

Error Codes

When the indoor unit encounters a recognized error on different models ,

1. the running LED with flash in a corresponding series, the timer LED may turn on or begin flashing;
2. an error code will be displayed;
3. both 1 and 2.

These error codes are described in the following tables:

Running Lamp	Timer Lamp	Display	Information	Solution
--	--	dF	Defrost	Normal Display not error code
--	--	CL	Filter cleaning reminder(power on display for 15 seconds)	
--	--	CL	Active clean	
--	--	nF	Filter replacement reminder(power on display for 15 seconds)	
--	--	FP	Heating in room temperature under 8°C	
--	--	FC	Forced cooling	
--	--	AP	AP mode of WIFI connection	
--	--	CP	Remote switched off	
1 time	OFF	EH 00/EH 0A	Indoor unit EEPROM parameter error	TS01-IDU
2 times	OFF	EL 01	Indoor/outdoor unit communication error	TS02-S-INV
3 times	OFF	EH 02	Zero-crossing signal detection error	TS03
4 times	OFF	EH 03	The indoor fan speed is operating outside of the normal range	TS04-S-IDU
5 times	OFF	EC 51	Outdoor unit EEPROM parameter error	TS01-ODU
5 times	OFF	EC 52	Condenser coil temperature sensor T3 is in open circuit or has short circuited	TS05-ODU
5 times	OFF	EC 53	Outdoor room temperature sensor T4 is in open circuit or has short circuited	TS05-ODU
5 times	OFF	EC 54	Compressor discharge temperature sensor TP is in open circuit or has short circuited	TS05-ODU
5 times	OFF	EC 56	Evaporator coil outlet temperature sensor T2B is in open circuit or has short circuited(for free-match indoor units)	TS05-ODU
6 times	OFF	EH 60	Indoor room temperature sensor T1 is in open circuit or has short circuited	TS05-IDU
6 times	OFF	EH 61	Evaporator coil middle temperature sensor T2 is in open circuit or has short circuited	TS05-IDU
12 times	OFF	EC 07	The outdoor fan speed is operating outside of the normal range	TS04-ODU
9 times	OFF	EH b	Indoor PCB/Display board communication error	TS07
8 times	OFF	EL 0C	Refrigerant leakage detection	TS06-INV
7 times	FLASH	PC 00	IPM malfunction or IGBT over-strong current protection	TS09-S
2 times	FLASH	PC 01	Over voltage or over low voltage protection	TS10-S
3 times	FLASH	PC 02	Top temperature protection of compressor or High temperature protection of IPM module or High pressure protection	TS11-S-INV
5 times	FLASH	PC 04	Inverter compressor drive error	TS12-S
1 time	FLASH	PC 08	Current overload protection	TS08-S
6 times	FLASH	PC 40	Communication error between outdoor main chip and driven chip	TS33
7 times	FLASH	PC 03	Low pressure protection	TS13-INV
1 times	ON	--	Indoor units mode conflict(match with multi outdoor unit)	TS14

For other errors: The display board may show a garbled code or a code undefined by the service manual. Ensure that this code is not a temperature reading.

Troubleshooting: Test the unit using the remote control. If the unit does not respond to the remote, the indoor PCB requires replacement. If the unit responds, the display board requires replacement.

European Disposal Guidelines

This marking is shown on the product or in its literature, indicates that electrical waste and electrical/electronic equipment should not be mixed with general household waste.

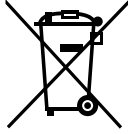

Correct Disposal of This Product (Electrical Waste & Electrical/Electronic Equipment)

This appliance contains refrigerant and other potentially hazardous materials. When disposing of this appliance, the law requires special collection and treatment. ***DO NOT* dispose of this product as household waste or unsorted municipal waste.**

When disposing of this appliance, you have the following options:

- Dispose of the appliance at the designated municipal electronic waste collection facility.
- When buying a new appliance, the retailer will take back the old appliance free of charge.
- The manufacturer will take back the old appliance free of charge.
- Sell the appliance to certified scrap metal dealers.

Special Notice

Disposing of this appliance in the forest or other natural surroundings endangers your health and is also harmful to the environment. Hazardous substances may leak into the ground water and enter the food chain.

Installation & Owner's Manual



MRCOOL®

COMFORT MADE SIMPLE

Easy Pro™ Fast Connect®