

SKU# 1005702744 Model# CA9aA026FR1D25
SKU# 1006875306 Model# CA9aA026FR1B25N
SKU# 1006875304 Model# CA9aA026FR1G25N

HAMPTON BAY®

USE AND CARE GUIDE

INTERIOR LED FLUSHMOUNT WITH NIGHTLIGHT FEATURE

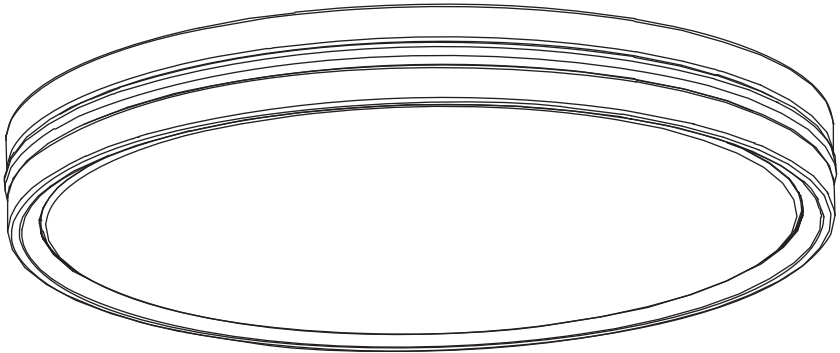

Questions, problems, missing parts? Before returning to the store,
call Hampton Bay Customer Service
8 a.m. - 7 p.m., EST, Monday – Friday, 9 a.m. – 6 p.m., EST, Saturday

1-800-841-1350

HAMPTONBAY.COM

THANK YOU

We appreciate the trust and confidence you have placed in Hampton Bay through the purchase of this interior LED flushmount. We strive to continually create quality products designed to enhance your home. Visit us online to see our full line of products available for your home improvement needs. Thank you for choosing Hampton Bay!

Table of Contents

Table of Contents	2
Safety Information	2
Warranty	2
What is covered	2
What is not covered	2

Pre-Installation	3
Planning Installation	3
Installation	4
Care & Cleaning	6
Troubleshooting	6
Compatibility.....	6

Safety Information

WARNING: PRODUCT MUST BE INSTALLED BY A PERSON FAMILIAR WITH THE CONSTRUCTION AND OPERATION OF THE PRODUCT AND THE HAZARDS INVOLVED, IN ACCORDANCE WITH THE APPLICABLE INSTALLATION CODE.

Carefully read and understand the information given in this manual before beginning the assembly and installation. Failure to do so could lead to electric shock, fire or other injuries which could be hazardous or even fatal.

- Be sure the electricity to the wires you are working on is shut off. Either remove the fuse or turn off the circuit breaker.
- Changes or modifications not expressly approved by the party responsible for compliance could void the user's authority to operate the equipment.



WARNING: Risk of fire or electric shock. LED Flushmount installation requires knowledge of luminaire electrical systems. If not qualified, do not attempt installation. Contact a qualified electrician.



WARNING: To prevent wiring damage or abrasion, do not expose wiring to edges of sheet metal or other sharp objects.

NOTICE: Do not make or alter any open holes in an enclosure of wiring or electrical components during installation.

NOTICE: Any changes or modifications to this unit not expressly approved by the party responsible for compliance could void the user's authority to operate the equipment

NOTE: This equipment has been tested and found to comply with the limits for a Class B digital device, pursuant to part 15 of the FCC Rules. These limits are designed to provide reasonable protection against harmful interference in a residential installation. This equipment generates, uses and can radiate radio frequency energy and, if not installed and used in accordance with the instructions, may cause harmful interference to radio communications. However, there is no guarantee that interference will not occur in a particular installation. If this equipment does cause harmful interference to radio or television reception, which can be determined by turning the equipment off and on, the user is encouraged to try to correct the interference by one or more of the following measures:
—Reorient or relocate the receiving antenna.
—Increase the separation between the equipment and receiver.
—Connect the equipment into an outlet on a circuit different from that to which the receiver is connected.
—Consult the dealer or an experienced radio/TV technician for help.

Warranty

WHAT IS COVERED

The manufacturer warrants this lighting fixture to be free from defects in materials and workmanship for a period of five (5) years from date of purchase. This warranty applies only to the original consumer purchaser and only to products used in normal use and service. If this product is found to be defective, the manufacturer's only obligation, and your exclusive remedy, is the repair or replacement of the product at the manufacturer's discretion, provided that the product has not been damaged through misuse, abuse, accident, modifications, alterations, neglect or mishandling.

WHAT IS NOT COVERED

This warranty shall not apply to any product that is found to have been improperly installed, set-up, or used in any way not in accordance with the instructions supplied with the product. This warranty shall not apply to a failure of the product as a result of an accident, misuse, abuse, negligence, alteration, or faulty installation, or any other failure not relating to faulty material or workmanship. This warranty shall not apply to the finish on any portion of the product, such as surface and/or weathering, as this is considered normal wear and tear.

The manufacturer does not warrant and specially disclaims any warranty, whether express or implied, of fitness for a particular purpose, other than the warranty contained herein. The manufacturer specifically disclaims any liability and shall not be liable for any consequential or incidental loss or damage, including but not limited to any labor / expense costs involved in the replacement or repair of said product.

Contact the Customer Service Team at 1-800-841-1350 or visit www.HAMPTONBAY.com.

Pre-Installation

PLANNING INSTALLATION



WARNING: Shut off power at the circuit breaker or fuse panel before removing the old fixture.

Read all instructions before assembly. Before starting installation of this fixture or removal of a previous fixture, disconnect the power by turning off the circuit breaker or by removing the fuse at the fuse box. To avoid damaging this product, assemble it on a soft, non-abrasive surface such as carpet or cardboard.



NOTE: Keep your receipt and these instructions for proof of purchase.

TOOLS REQUIRED



Wire Strippers



Safety Goggles



Ladder



Gloves



Flathead Screwdriver



Phillips Screwdriver



Electrical Tape



Wire Cutters

HARDWARE INCLUDED



NOTE: Hardware not shown to actual size.



AA



BB

Part	Description	Quantity
AA	Wire nut	3
BB	Mounting screw	2

Pre-Installation (continued)

PACKAGE CONTENTS

A _____

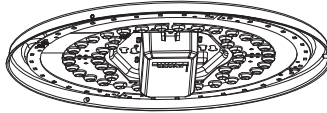

B _____

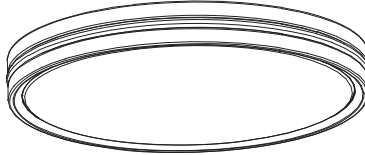

Part	Description	Quantity
A	Housing	1
B	Diffuser	1

Installation

1 Adjust the color temperature

- Hold the housing (A) of the fixture and twist the diffuser (B) counter clockwise to remove.

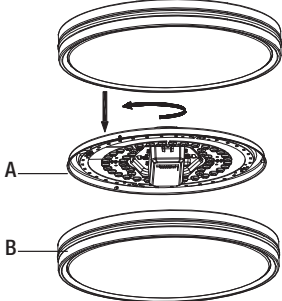

- Select your favorite color temperature (CCT) from five options: 2700K, 3000K, 3500K, 4000K, or 5000K by the toggle switch located on the driver box.

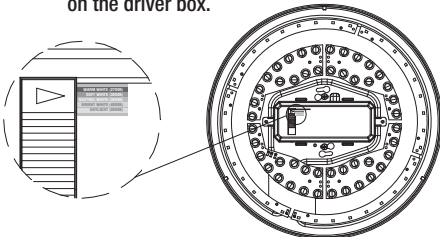

2 Install mounting screws

- Install the junction box screws (BB) onto the junction box and leave a little gap.

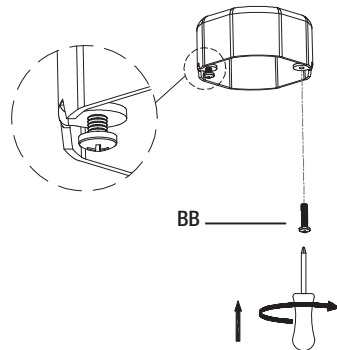

Installation (continued)

3 Connect the wires

- Connect the black and white wires of the fixture with two wires of the same colors from the junction box. Secure together using wire nuts (AA).
- Connect the grounding wire of the fixture with the one from the junction box. Secure together using a wire nut (AA).

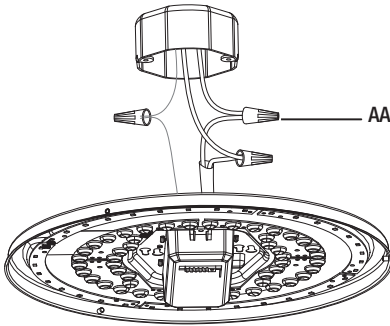

4 Mount the housing

- Align the keyholes on the housing (A) with the mounting screws (BB). Then rotate the housing to securely fit to the junction box and tighten screws to secure.

CAUTION: With the small space inside junction box for electrical wiring. Check wiring to make sure it is not cut or damaged which can cause an electrical short.

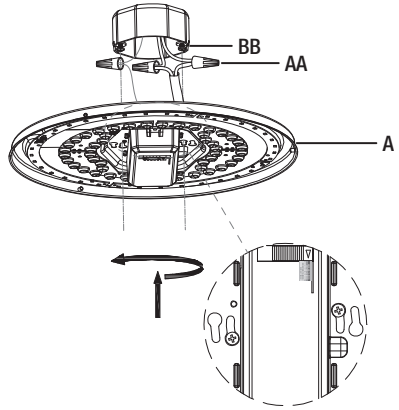

5 Install the shade

- Align the slots on the shade (B) with the buckle point on the inside of the housing (A). Turn the shade (B) clockwise carefully and confirm it locks into place.

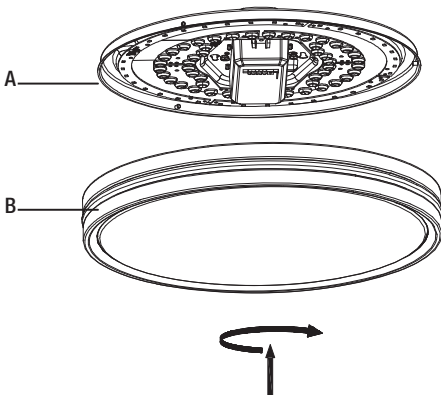

6 Turn on the light

- Restore power to the junction box. Turn the light switch on to activate the fixture.
- Selecting Main Light or Night Light Mode
 - To turn on the main light mode, switch on the wall switch.
 - To change to night light mode, turn on the main light, then switch the wall switch off then back on again within 2 seconds.
- Note: The Main light will not provide light output while in night light mode.
 - To return to main light mode after using night light mode, switch the wall switch off then back on again within 2 seconds.

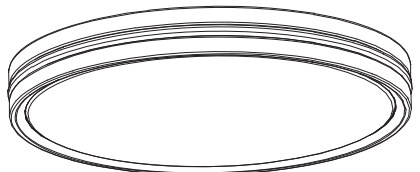

Care and Cleaning

- Clean the fixture with a soft, dry cloth.
- Do not use any cleaners with chemicals, solvents, or harsh abrasives.



WARNING: Shut off power at the circuit breaker or fuse panel before cleaning the fixture.

Troubleshooting

Problem	Possible Cause	Solution
The fixture will not light.	The power is off.	□ Ensure the power supply is On.
	The circuit breaker is off.	□ Ensure the circuit breaker is in the On position.
The fuse blows or the circuit breaker trips when the light is turned on.	The wires are crossed or the power wire is grounding out.	□ Check the wire connections. □ Contact a qualified electrician or call the Customer Service Team at 1-800-841-1350.
The flush mounts may become out of sync between the night light and main light mode when using multiple fixtures on one switch.	Forget to adjust the light mode to keep in sync before installation.	□ Adjust the existing flush mount to the main light mode, and then install the new flush mount. □ Turn on and turn off the wall switch within 2 seconds for 5 times, then turn on the switch and all the flush mounts will be reset and restore to main light mode.

Compatibility

FOR USE WITH DIMMER MODELS:

LUTRON: DVCL-153PR-WH, CTCL-153PDH-WH, TGCL-153PH-WH, MACL-153MH-WH, P-PKG1W-WH-R, MSCL-OP153MH-WH, MS-OPS2MH-WH, PD-6WCL-WH-R, MACL-153MR-WH, MACL-153MH-LA, CTCL-153PDH-IV, TGCL-153PR-WH, CTCL-153PR-WH, MRF2-6CL-WH, MRF2-6ND-120-WH, MACL-153M-WH, SCL-153P-WH, DVWCL-153PH-LA, DVF-103P-WH

LEVITON: R62-06674-POW, C22-6672-1LW, R50-IPL06-10M, LEVITON 6631, R68-6674-POT, R08-TSL06-1KT, M02-DSL06-3PW

COOPER: AAL06-C1

For a complete list of compatible dimmers, please visit Homedepot.com

This LED Flush Mount is designed to be surface-mounted onto a 3 in./4 in. junction box. Junction box types, sizes, and site conditions vary. Ensure compatibility with the fit, wiring, and mounting. Refer to the information below.

Recommended junction box type	Recommended distance between two keyholes
3 in.	2.75 in. /3.5 in.
4 in.	2.75 in. /3.5 in.

HAMPTON BAY®

Questions, problems, missing parts? Before returning to the store, call Hampton Bay Customer Service
8 a.m. – 7 p.m., EST, Monday – Friday, 9 a.m. – 6 p.m., EST, Saturday

1-800-841-1350

HAMPTONBAY.COM

Retain this manual for future use.

FCR compliance information is listed as below:
Responsible party: Leedarsen America, Inc.
Responsible party address: 300 Technology Court SE Suite 100, Smyrna, GA 30082
Telephone number: (678) 293-8382