



HDX 5-Tier Shelf

Components and Assembly Instructions





WARNING

- Unit must be placed on a level surface or leveled for use.
- Do not sit or stand on or allow anyone to climb, sit or stand on the assembled product.
- Mount the unit to the wall for tip over prevention, as unit can tip over causing severe injury or death.
- Mount the unit to the wall for max weight capacity, do not exceed claimed weight capacity.
- Distribute weight evenly on each shelf and keep heavier loads on the bottom.
- Do not exceed recommended shelf spacing, stated on shelf label, by connecting poles.

CUSTOMER SERVICE/PARTS
If replacement parts or customer service is needed, please contact customer service by scanning the QR Code with your SmartPhone or by visiting requestpart.com.

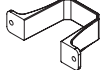

COMPONENTS

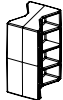
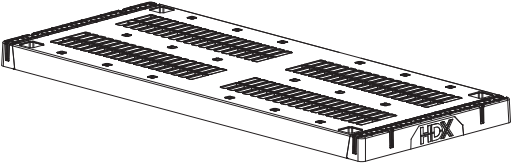
Threaded feet  x8	Foot collars  x8
Top cap  x8	Wall brackets  x4
Tall pole  x16	Short pole  x16
Interlocking Tees  x8	
Shelves  x5	

ASSEMBLY INSTRUCTIONS

STEP 1
Flip the first shelf over, then assemble four threaded feet with foot collars and insert into the bottom shelf.

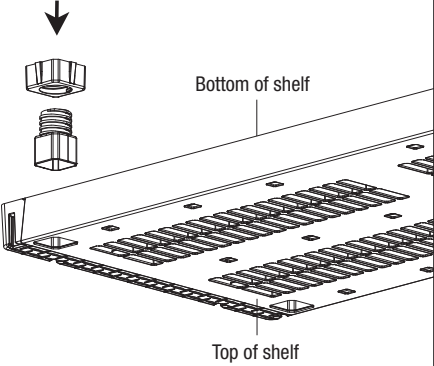

STEP 5
Insert top caps fully into place on the top shelf.

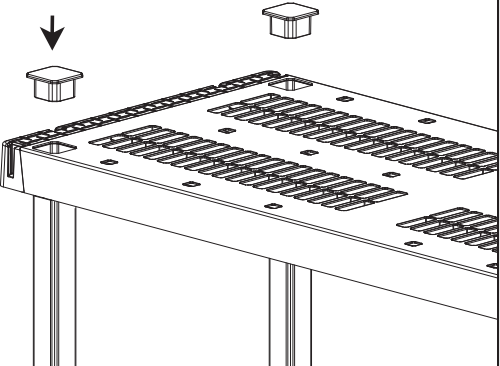

STEP 2
Flip the shelf over, so feet are touching the ground.

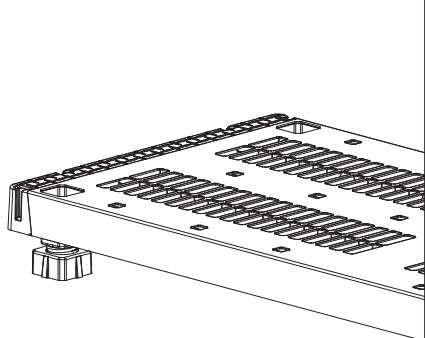

STEP 6
Move shelf into final location. Twist foot collars up or down to level shelf, if necessary.

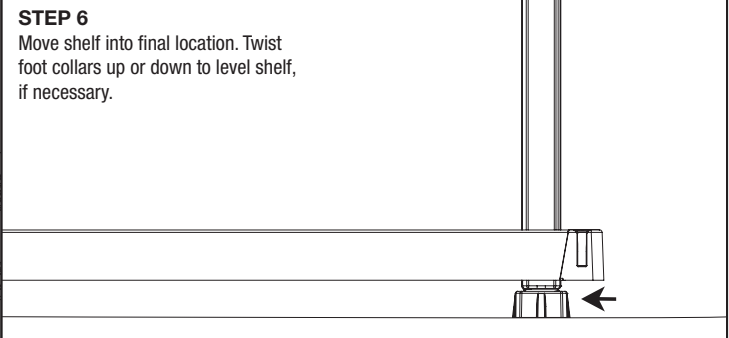

STEP 3
Insert tapered end of pole into top of shelf. Use either 4 short or 4 tall poles based on desired shelf height.

Short: 9 inches between shelves
Tall: 15.4 inches between shelves.

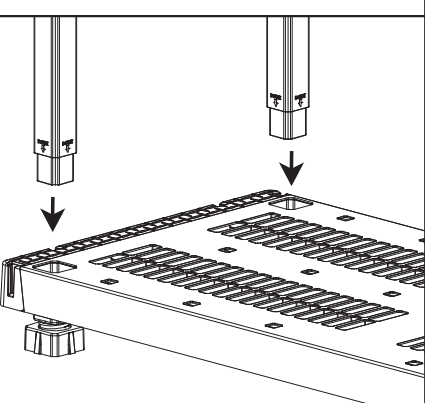

STEP 7
Secure wall brackets around poles under the desired top shelf. Secure wall brackets into stud or using wall anchors.

Warning Wall Brackets must be used for full shelf weight capacity.

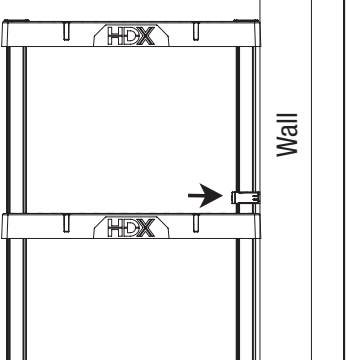

STEP 4
Line up the next shelf with the inserted poles and press firmly down until fully engaged. Repeat steps 3 & 4 to get to desired shelf height.

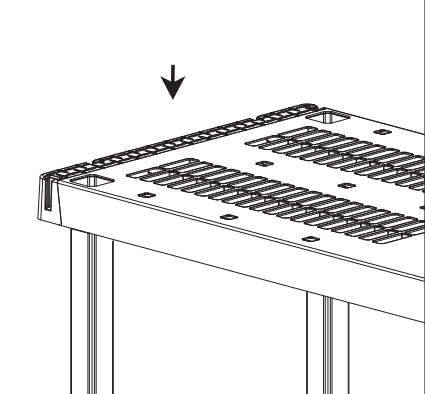

CUSTOMIZE SHELF HEIGHTS
Short and tall pole sizes create over 75 different configurations. Always be sure to use the same pole size to build each shelf section.

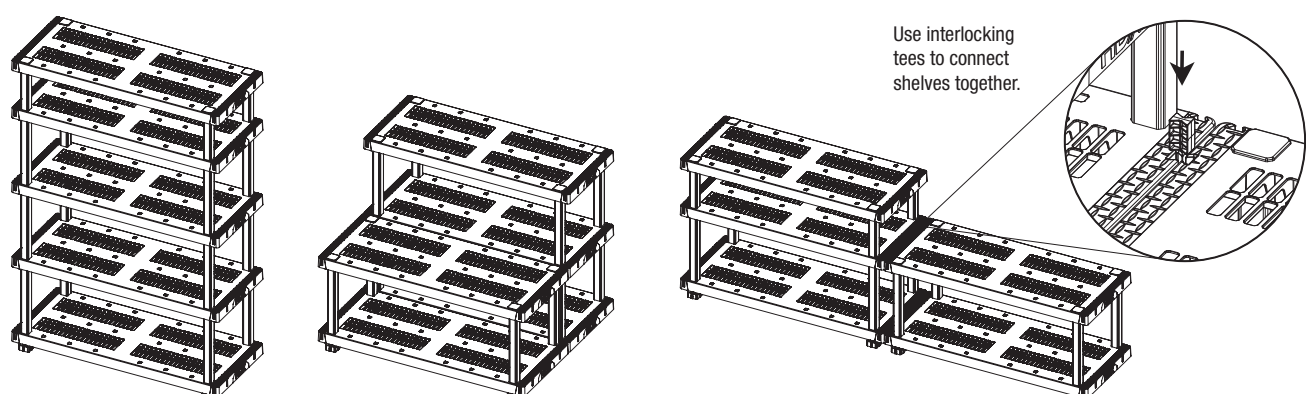

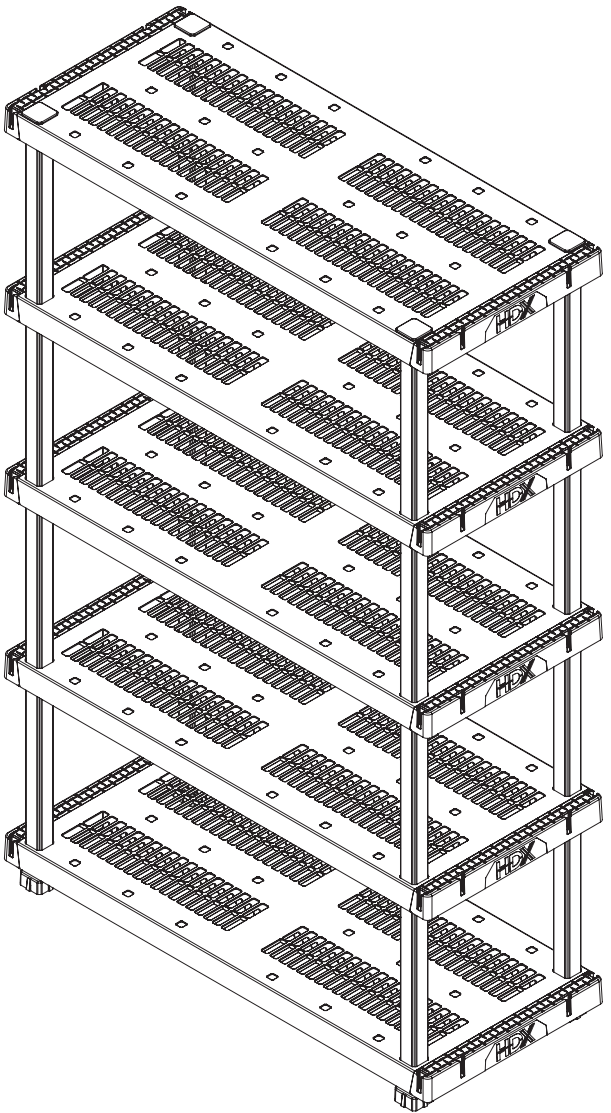

Use interlocking tees to connect shelves together.

