



CROSSOVER PRODUCT™

STRUCTURAL POST INSTALLATION INSTRUCTIONS

- Flush-Mount: pp. 2-5
- Fascia (Thru)-Mount: pp. 6-9
- Core-Mount: pp. 10-11

Compatible with
ENDURANCE™ and **TITAN PRO™**
Railing Systems



FLUSH-MOUNT POST INSTRUCTIONS

- Determine placement of all structural posts before beginning installation.
- RDI railing kits are manufactured for a 36” or 42” finished rail height with a 2” standard bottom space.

COMPONENT LIST:

Check the kit to ensure all components are included.

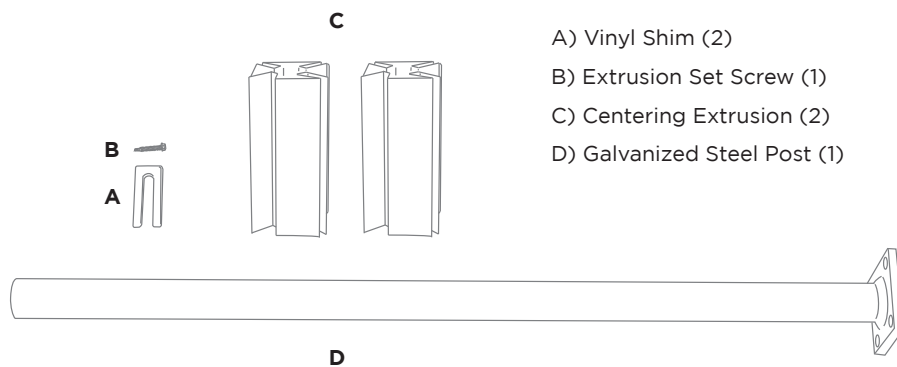

**Warning:
Always wear
safety goggles.**



1.

When installing a structural post in a flush-mount application, be sure that sufficient mounting structure exists to receive the post attachment fasteners. Install blocking under surface if necessary.

Tip:

Thru-bolting using 3/8" stainless steel bolts is recommended to attain maximum strength and durability (Fig. 1).

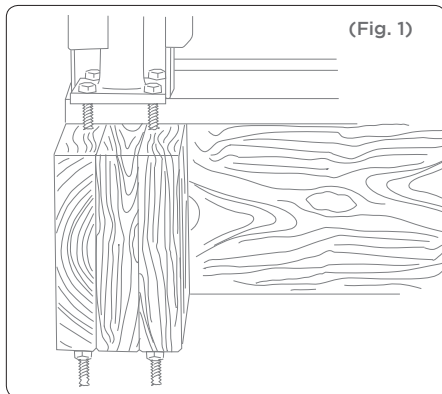

(Fig. 1)

2.

Determine the rail direction and orient the structural post flange base accordingly (Fig. 2).

Tip:

When a structural post will act as the transition point between level and stair rail at other than a right angle, be sure to set the post in line with the stair rail. This will allow the use of any RDI specialty bracket kit on the level rail and standard RDI stair brackets.

Tip:

If using Endurance® Deck Rail™ with Decorative Cap, please refer to the instruction booklet included in the Deck Rail kit (or www.rdirail.com) for finished post height.

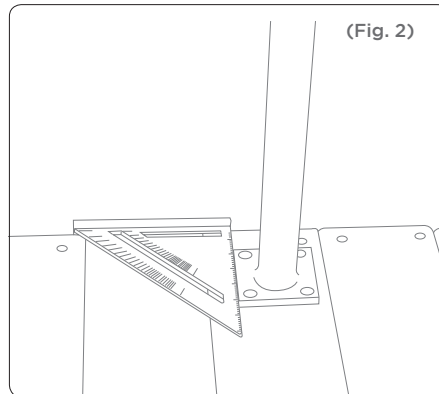

(Fig. 2)

3.

After mounting location is confirmed, pre-drill for permanent mounting hardware (Fig. 3). Check and adjust structural post for plumb using supplied vinyl shims (Fig. 4).

Secure the post through all four base attachment holes (Fig. 5).

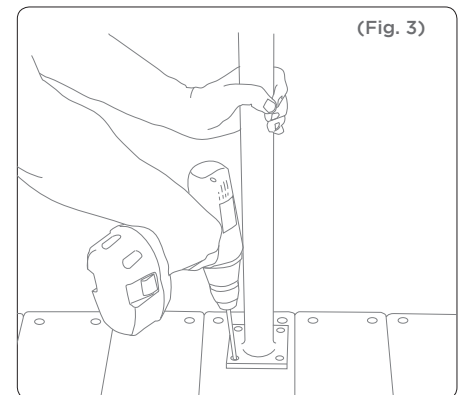

(Fig. 3)

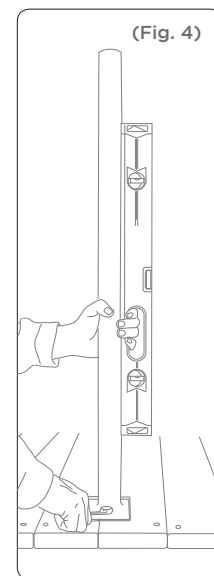

(Fig. 4)

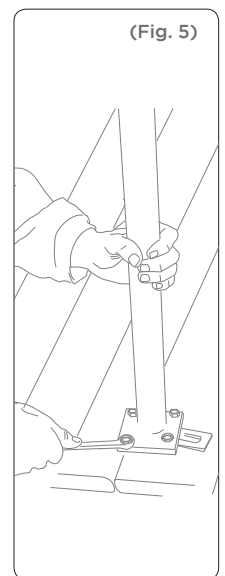

(Fig. 5)

4.

Position the lower extrusion aligning it with the proposed railing direction (Fig. 6). Ensure that the pre-mounted top centering extrusion is aligned as well.

Note:

RDI railing kits are manufactured for a 36" or 42" finished-rail height with a 2" standard bottom space. If other heights or bottom spaces are desired, adjust the height of the centering extrusion accordingly.

Note:

If installing Endurance® ADA Hand Rail™ onto a post, determine the mounting location and create sufficient attachment by blocking out post with 1" material or by purchasing a third centering extrusion and installing at desired location (Fig 7).

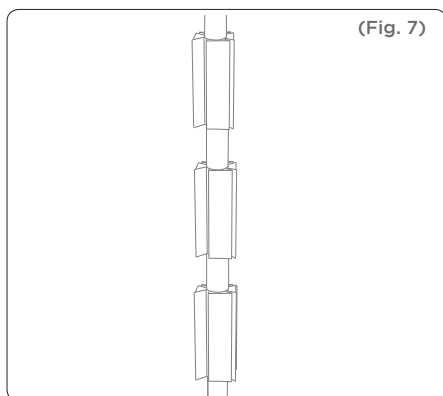
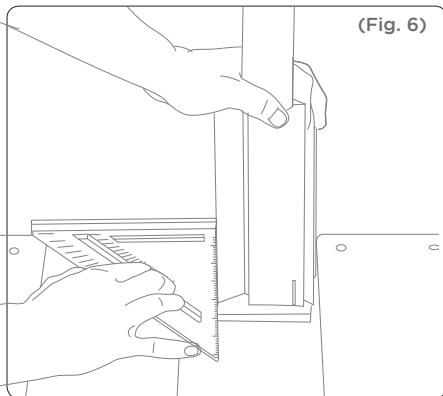

5.

Slide the vinyl sleeve over the centering extrusion. Mark and cut the sleeve to length.

Tip:

The sleeve should extend above the desired rail height enough to allow clearance for a post cap (Fig. 8).

Note:

If using a turned newel sleeve*, be sure to leave enough flat area to accept rail attachment brackets (Fig. 9). Remove the top centering extrusion set screw and the extrusion. Use this screw to attach the bottom centering extrusion to the post. Slide the top extrusion onto the post after the turned sleeve has been installed.

*Endurance rail kits measure 34" or 40" from the bottom of the bottom rail to the top of the top rail.

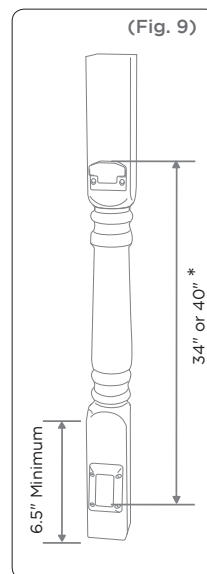
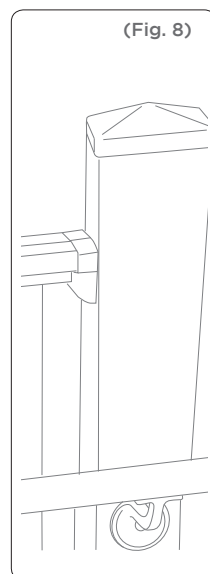

6.

Slide the vinyl sleeve over the structural post and the centering extrusions (Fig. 10).

Note:

The top centering extrusion may need to be repositioned depending on your application. For example, in stair railing applications, the centering extrusion may need to be raised to allow attachment of the stair brackets.

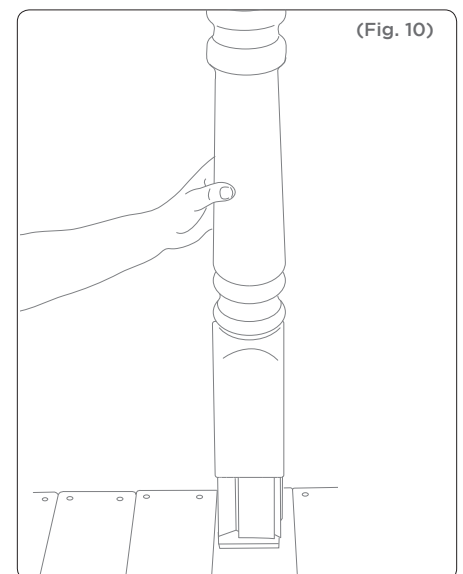



7.

The post is now ready to accept the railing installation (Fig. 11).

Note:

Post caps should be glued on AFTER installation is complete. Simply apply a small amount of vinyl adhesive to the cap to permanently secure.

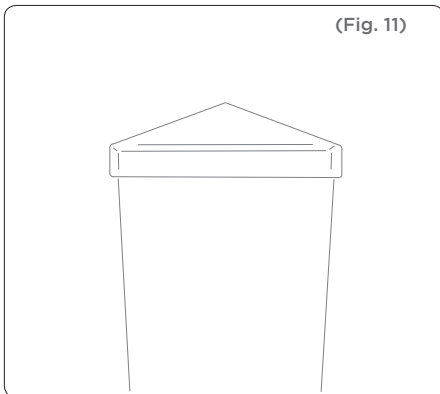



FASCIA (THRU)-MOUNT POST INSTRUCTIONS

- Determine placement of all structural posts before beginning installation.
- RDI railing kits are manufactured for a 36” or 42” finished-rail height with a 2” standard bottom space.

COMPONENT LIST:

Check the kit to ensure all components are included.

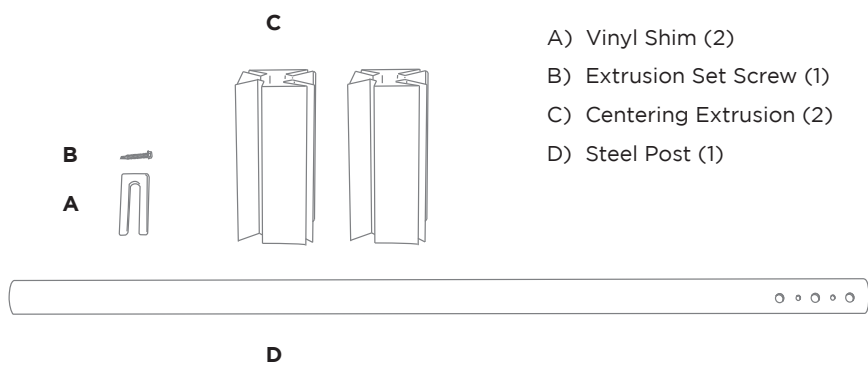

Warning:
Always wear
safety goggles.



1.

When installing a structural post in a fascia (thru)-mount application, be sure that sufficient mounting structure exists to receive post attachment fasteners.

When mounting to a straight face, three fasteners should be used (Fig. 1). In an inside corner application, five fasteners should be used to maximize strength in both directions (Fig 2).

Note:

Thru-bolting using 3/8" stainless steel bolts is recommended to attain maximum strength and durability.

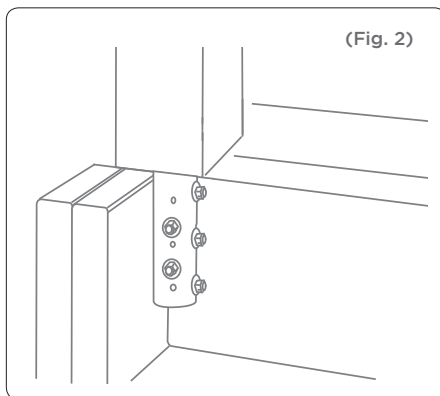
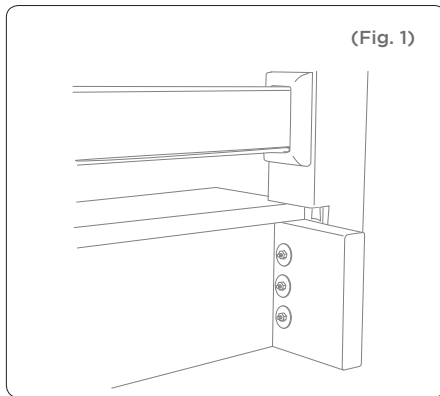

2.

Ensuring that the post is plumb from side-to-side and at the appropriate height, clamp in place (Fig. 3).

Posts should be installed at a height of 36" for an RDI residential railing kit and 42" for an RDI commercial railing kit.

Using two standard deck screws, temporarily secure the post in place through the two smaller holes in the post (Fig. 4).

Tip:

If using Endurance® Deck Rail™ with Decorative Cap, please refer to the instruction booklet included in the Deck Rail kit (or www.rdirail.com) for finished post height.

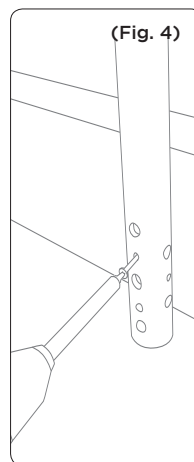
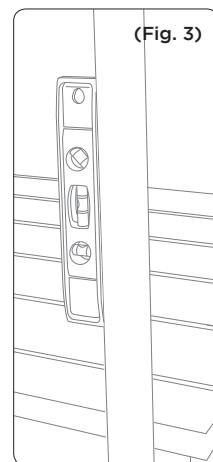

3.

After mounting location is confirmed, pre-drill for permanent mounting hardware (Fig. 5). Using the provided vinyl shims, plumb the post and permanently secure with at least three mounting fasteners (Fig. 6,7).

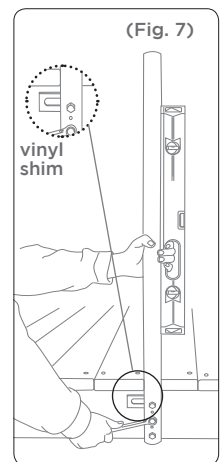
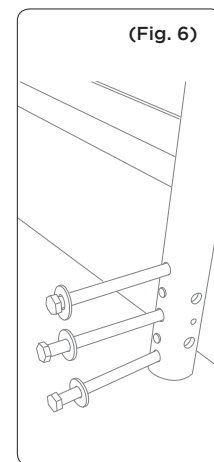
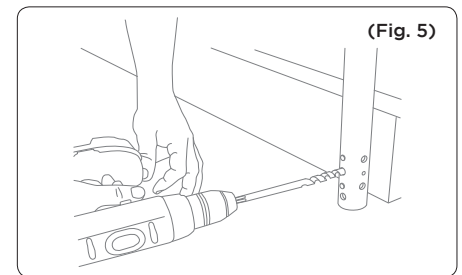

4.

Position the lower extrusion aligning it with the proposed railing direction (Fig. 8). Ensure that the pre-mounted top centering extrusion is aligned as well.

Note:

RDI railing kits are manufactured for a 36" or 42" finished-rail height with a 2" standard bottom space. If other heights or bottom spaces are desired, adjust the height of the centering extrusion accordingly.

Note:

If installing Endurance® ADA Hand Rail onto post, determine the mounting location and create sufficient attachment by blocking out post with 1" material or by purchasing a third centering extrusion and installing at desired location (Fig 9).

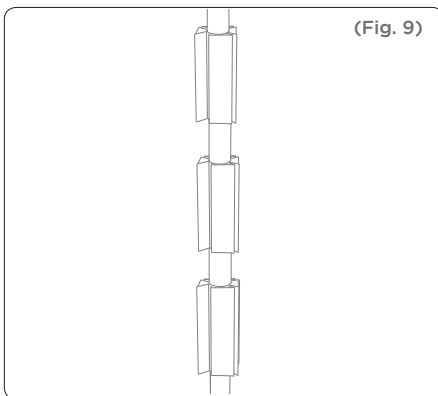
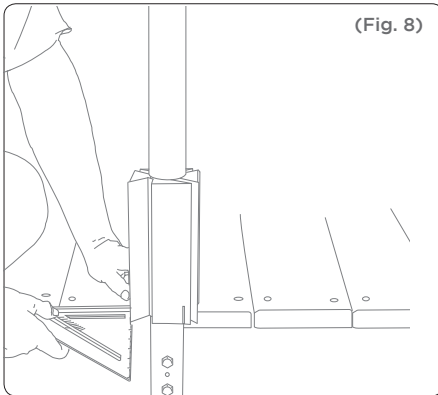

5.

Slide the vinyl sleeve over the centering extrusion. Mark and cut the sleeve to length.

Tip:

The sleeve should extend above the desired rail height enough to allow clearance for a post cap (Fig. 10).

Note:

If using a turned newel sleeve*, be sure to leave enough flat area to accept rail attachment brackets (Fig. 11). Remove the top centering extrusion set screw and the extrusion. Use this screw to attach the bottom centering extrusion to the post. Slide the top extrusion onto the post after the turned sleeve has been installed. *Endurance rail kits measure 34" or 40" from the bottom of the bottom rail to the top of the top rail.

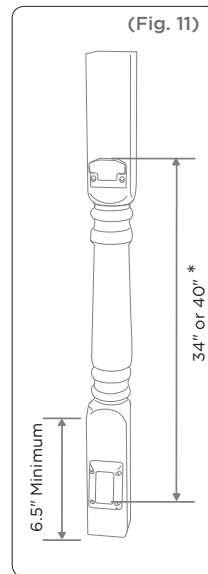
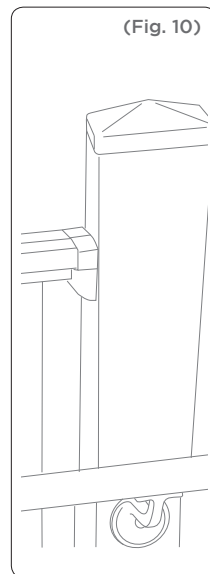

6.

Slide the cut vinyl sleeve over the structural post and the centering extrusions (Fig. 12).

Note:

The top centering extrusion may need to be repositioned depending on your application. For example, in stair rail applications, the centering extrusion may need to be raised to allow attachment of the stair brackets.

Note:

In some cases, the vinyl sleeve will need to be notched to extend below the plane of the standing surface to hide the post tail and mounting hardware (Fig. 13). *Endurance rail kits measure 34" or 40" from the bottom of the bottom rail to the top of the top rail.

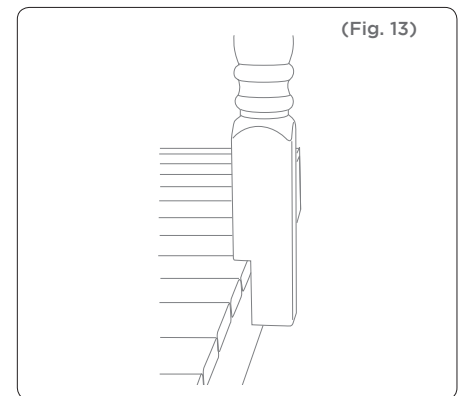
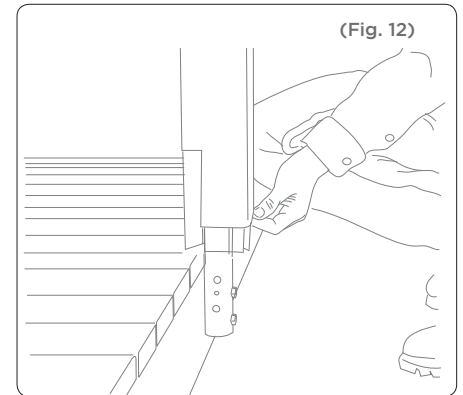



7.

The post is now ready to accept the railing installation (Fig. 14).

Note:

Post Caps should be glued on AFTER installation is complete. Simply apply a small amount of vinyl adhesive to the cap to permanently secure.

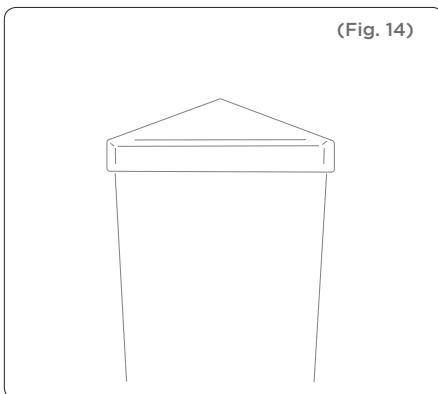



CORE-MOUNT POST INSTRUCTIONS

- Determine placement of all structural posts before beginning installation.
- RDI railing kits are manufactured for a 36” or 42” finished-rail height with a 2” standard bottom space.

COMPONENT LIST:

Check the kit to ensure all components are included

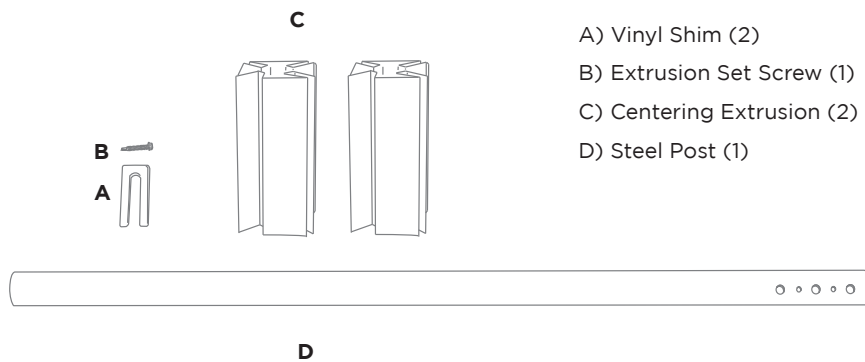

Warning:
Always wear
safety goggles.





1.

Consult your hydraulic cement manufacturer's specifications for core hole diameter and depth based on the final railing height for your installation. After depth and diameter have been confirmed, drill and remove the core from the hole (Fig. 1, 2).

2.

Place the post in the hole and adjust for plumb (Fig. 3). Temporarily secure in place using clamps and wood supports (Fig. 4).

Mix and pour hydraulic cement as per manufacturer's instructions (Fig. 5).

3.

After post has cured, follow the instructions for RDI flush-mount structural post, beginning with Step 4.

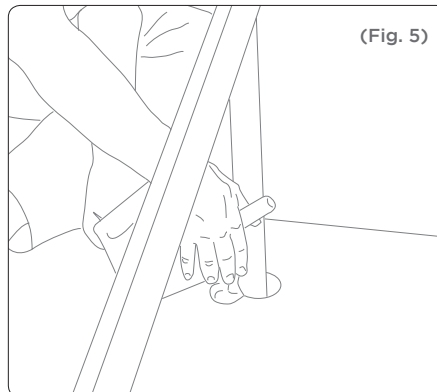
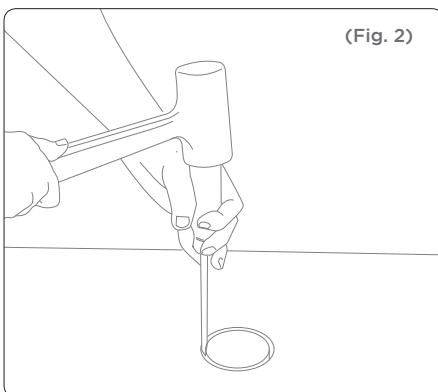
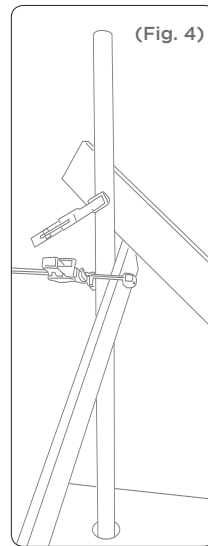
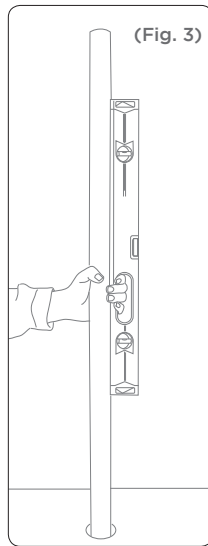
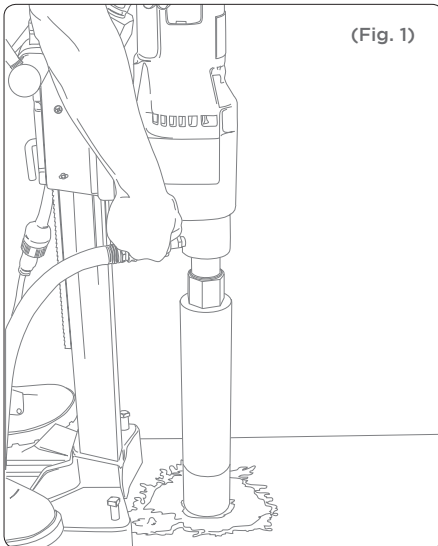



rdi[®]

RAILING DYNAMICS, INC.
FOR HOME, FOR LIFE.™

135 STEELMANVILLE ROAD
EGG HARBOR TOWNSHIP, NJ 08234

TEL: (877) 420-7245
FAX: (866) 277-5160
E-MAIL: CS@RDIRAIL.COM
URL: WWW.RDIRAIL.COM

Endurance[®]