

300 LB IMPACT TESTING



CONSULTANTS
· ENVIRONMENTAL
· GEOTECHNICAL
· MATERIALS
· FORENSICS

October 15, 2020

Mr. John Ruprecht
Clear View Glass Railings
737 Quentin Avenue South
Lakeland, MN 55043

Re: Field test of Clear View Glass Railings “Hercules Glass” guardrail panel
AET Project #: 05-20608

Dear Mr. Ruprecht,

This letter reports tests performed on Clear View’s Hercules Glass panel on April 21, 2020 by Clear View and your agents at 1141 120th Street in Roberts, Wisconsin. These tests were the first of a series of tests that included the dynamic loading test described below, and vertical and horizontal static tests. All tests were performed to provide test data that the panels meet International Building Code (IBC) requirements.

The panel tested was a 13mm thick tempered and laminated glass panel with the brand name Hercules Glass. It measured 13mm thick x 39.37” tall x 60” wide, and is supported by two metal “spigots”, each located 12” inside a side edge of the panel (spaced 36” apart). The panel are secured in slots within the spigots, and the spigots are bolted to the supporting structure. The total height of the panel and spigots is 42”.

The dynamic testing involved hanging 300# sandbags against the side of the panel at the panel’s top edge. The sandbags were pulled back 33” and released, causing the sandbags to swing into the top of the panel, simulating a dynamic horizontal guardrail load – a person or object falling into the panel. The panel deflected approximately 4” and returned to its original shape, without experiencing any damage.

Don’t hesitate to contact us with questions about this testing or any other aspects of this evaluation program.

Sincerely,
American Engineering Testing, Inc.

A handwritten signature in black ink that reads 'Chris Hartnett'.

Chris Hartnett, PE
Principal Engineer
MN Lic. No. 42371
Phone: 651-647-2750
chartnett@amengtest.com

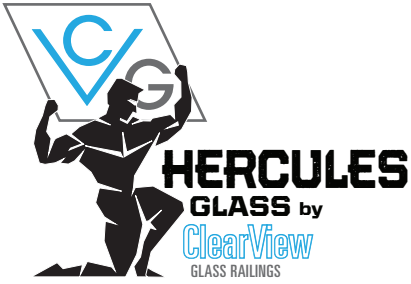

300 LB IMPACT TEST

This is an impact test of 60" x 39.37" x .53" thick CVGR Hercules tempered laminated glass panel mounted in two 316 solid core stainless steel spigots. Spigots are centered on glass 36" apart, 12" from end of glass. Plastic bags are weighted with 300 lbs of media, pulled back 36" from CVGR glass panel and then released to free fall to impact the top center of the CVGR panel. There is no damage or failure of the CVGR Hercules Glass panel or spigots from this 300 lb impact.

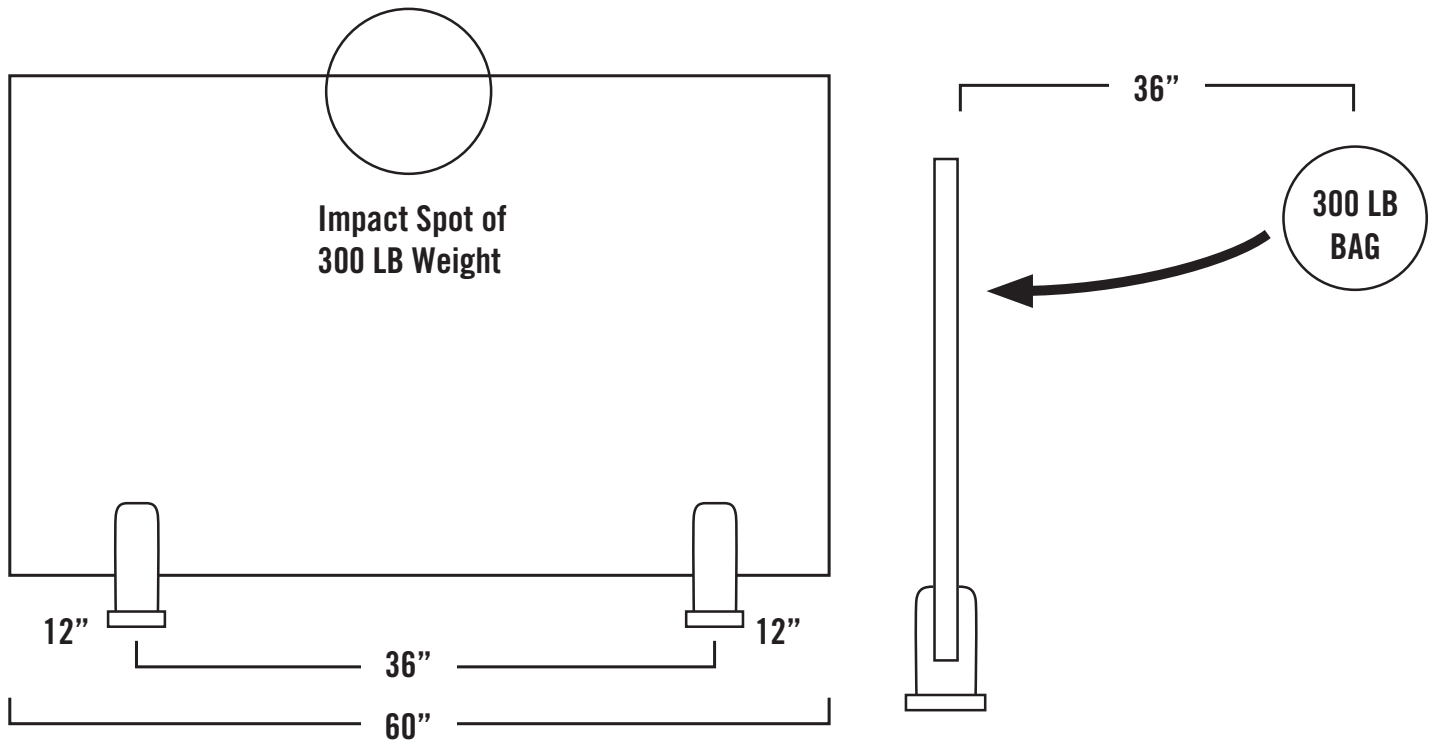

VIDEO STILLS ON REVERSE SIDE >

CVGR HERCULES GLASS 300 LB IMPACT TEST VIDEO STILLS

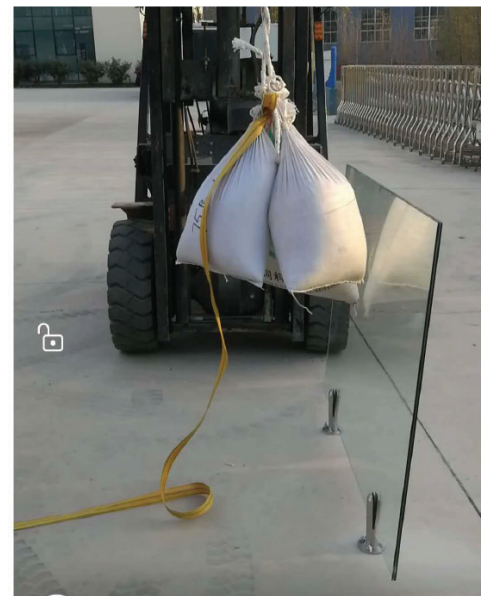
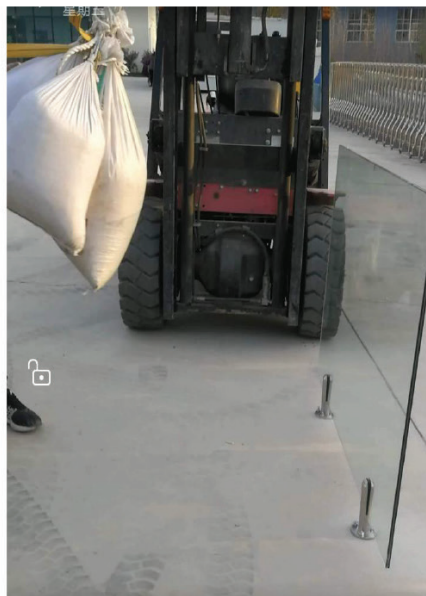
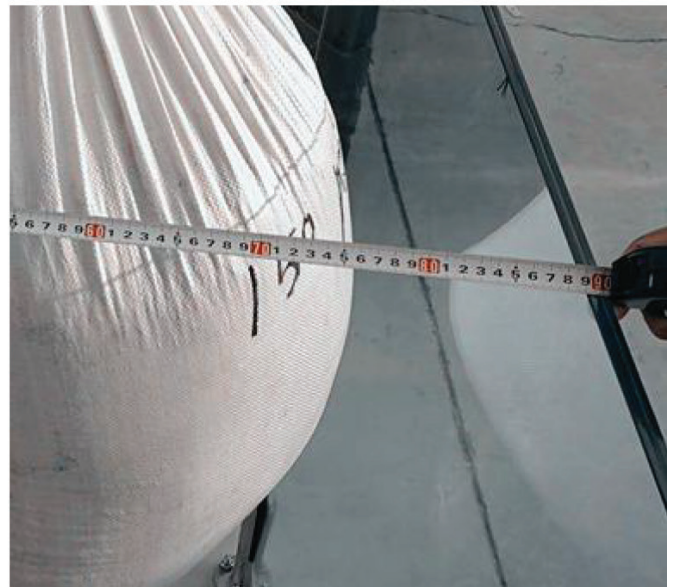

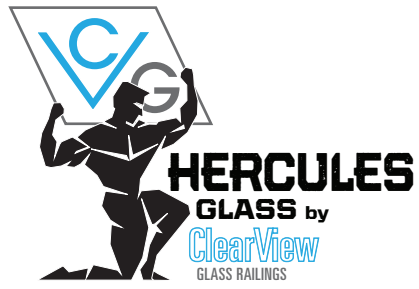

LOAD TESTING



CONSULTANTS
· ENVIRONMENTAL
· GEOTECHNICAL
· MATERIALS
· FORENSICS

November 13, 2020

Mr. John Ruprecht
Clear View Glass Railings
737 Quentin Avenue South
Lakeland, MN 55043

Re: Code Requirements & Static Test of Clear View Glass Railings “Hercules Glass” guardrail panel
AET Project #: 05-20608

Dear Mr. Ruprecht,

This letter reports building code requirements for guardrails; it also reports test methods and results for static tests performed on Clear View’s Hercules Glass panel.

The International Building Code (IBC) and International Residential Code (IRC) are “model codes” created by the International Code Council, intended to be used by states and municipalities as they publish their own building codes. Section 1607.8 of the IBC requires that “handrails and guards shall be designed to resist a linear load of 50 plf.” It also requires the system to resist a 200# concentrated load that produces the “maximum load effect” on any element within the system. The 2018 IRC Table R201.5 extends this requirement into residential construction. It is understood within the building design industry that lateral loads applied to the top of the panel create the maximum load effect; structural design assumes this loading condition.

Section 1607.8 of the IBC also refers to IBC section 2407 Glass in Handrails and Guards that adds a requirement for all-glass handrails and guards to “be laminated glass constructed of fully tempered or heat-strengthened glass”; this requirement was added in the 2015 IBC code cycle. Section 2407.1.1 adds the significant requirement: “a design factor of four shall be used for safety”. This addition bumps up the linear load to 200 plf and the concentrated load to 800#..

Exterior glass guardrail panels are designed to resist two load types: wind loads, and “live” loads such as a person or object pushing on or striking the panel from the side or from above. Wind loading on a panel can vary greatly based on location, terrain (wooded vs open) and elevation above ground; these are governed by publication ASCE 7 (American Society of Civil Engineers) Minimum Design Loads for Buildings and Other Structures. Wind speeds of 115 psf are used to calculate wind pressures against the glass, which generally vary from 17 psf (2nd story in wooded area) to 35 psf (30 stories tall in open terrain). The wind speeds required to match the stresses created by the 800# point load are 192 mph for the 42” tall panel and 215 mph for the 36” tall panel; these are only seen in a Category 5 hurricane or a tornado. Therefore, the 800# horizontal point load requirement is the worst-case scenario for the panels. Calculation methods to arrive at these values include computer modeling using finite element analysis,

using criteria specific to Clear View’s panels and support configuration.

Hercules Glass Testing

Testing was performed on the Hercules Glass panel by Clear View’s glass supplier, to simulate the forces created by 800# horizontal and vertical point loads on the panel (loads are not required to be simultaneous). The vertical load test is fairly straightforward and is shown in photo 1. Note: the intent was to load the panel to failure; however, the testers ran out of sandbags at 2,520 pounds, without failure.



Photo 1: Panel loaded vertically with 2,520 pounds.

Given the difficulty of pushing an 800# load horizontally against the panel, a test rig was set up that supports the panel on its side and places sandbags vertically on the panel. The panel is supported 28” from the top of panel (creating a 28” cantilever), with a heavy counterweight holding down the bottom of the panel mounted in its spigots. Sandbags were placed at the top edge of the panel until failure. See Diagram 1 and photo 2. The panel failed after one minute with 820 pounds loaded on its edge, which is equivalent to 547 pounds for a 42” tall panel. Using a finite element computer model, it was determined that the stresses caused by the 547 pound point load are equivalent to those caused by a 147 mph wind.

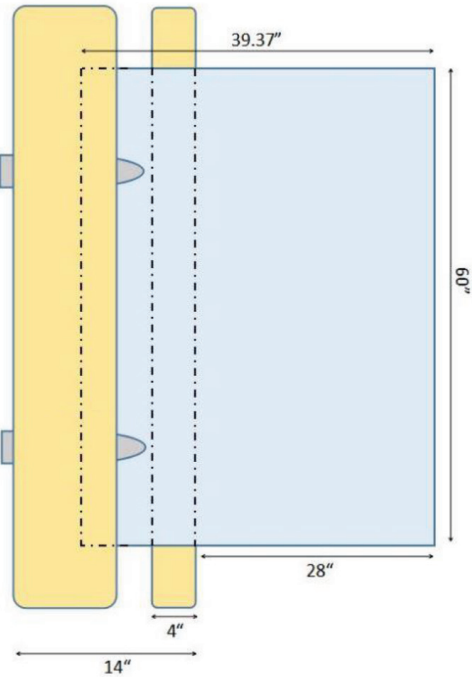

Diagram 1: Test rig lying on its side, looking from above, showing panel supported at 28” and at bottom of panel



Photo 2: Loading of panel with sandbags, simulating horizontal force

Due to the laminate construction of the panels (similar to a vehicle windshield), the panel broke into small pieces that were retained within the panel, preventing dangerous flying glass debris. See photo 3.



Photo 3: Panel after failure, showing all glass intact within laminate structure.

This test shows that the panel meets the intent to create a strong and safe barrier that can withstand reasonable loading (factor of safety of 2.5), and does not explode with dangerous glass shards during excessive loading.

Don't hesitate to contact us with questions about this testing or any other aspects of this evaluation program.

Sincerely,
American Engineering Testing, Inc.

Chris Hartnett, PE
Principal Engineer
MN Lic. No. 42371
Phone: 651-647-2750
chartnett@amengtest.com



CALIFORNIA PROFESSIONAL ENGINEERS TESTING APPROVAL



May 25, 2021 (Updated July 28, 2023)

Project No. 1210339C

Mr. John Ruprecht
CLEAR VIEW GLASS RAILINGS COMPANY
737 Quentin Avenue South
Lakeland, MN 55043

[Email: John@CVGRailings.com](mailto:John@CVGRailings.com)

Subject: ClearView Glass Railings

Dear Mr. Ruprecht:

This letter report summarizes our review and findings of the American Engineering Testing, Inc. (AET) reports dated October 15, 2020 and November 13, 2020 regarding Clear View's Hercules Glass panel testing.

The above reports are attached as an Appendix.

FINDINGS

AET determined that a 200 pounds (lbs) point load would be the required design load for this type of application, ie. glass handrails. This calculation is based on IBC (International Building Code) Section 1607.8.1.1.

I. October 15, 2020 Report

AET performed a dynamic test on a 60" x 40" glass panel. A pendulum load of 300 pounds was allowed to impact the panel at a height of 36" from the top of the panel. No damage was observed to the glass panel.

II. November 13, 2020 Report

AET performed static testing with a load of 800 pounds (this has a factory of safety of 4) vertical point load on a 60" x 40" glass panel. The tested panel withstood 800 lbs without failure.

AET also performed static testing with a load of 800 pounds horizontal (out-of-plane) load on the glass panel. The panel resisted a load of up to 820 pounds, loaded on its edge.

Mr. John Ruprecht
CLEAR VIEW GLASS RAILINGS COMPANY
ClearView Glass Railings
May 25, 2021 (Updated July 28, 2023)
Page 2

CONCLUSION

The calculations and tests performed by AET conform to the applicable industry standards and are valid for the stated application.

Please call if you have any questions regarding the above.

Sincerely,

APPLIED MATERIALS & ENGINEERING, INC.

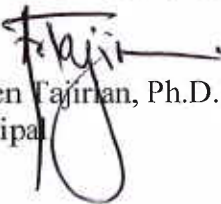
Armen Tajirian, Ph.D., SE
Principal



Appendix



October 15, 2020

Mr. John Ruprecht
Clear View Glass Railings
737 Quentin Avenue South
Lakeville, MN 55043

Re: Field test of Clear View Glass Railings “Hercules Glass” guardrail panel
AET Project #: 05-20608

Dear Mr. Ruprecht,

This letter reports tests performed on Clear View’s Hercules Glass panel on April 21, 2020 by Clear View and your agents at 1141 120th Street in Roberts, Wisconsin. These tests were the first of a series of tests that included the dynamic loading test described below, and vertical and horizontal static tests. All tests were performed to provide test data that the panels meet International Building Code (IBC) requirements.

The panel tested was a 13mm thick tempered and laminated glass panel with the brand name Hercules Glass. It measured 13mm thick x 39.37” tall x 60” wide, and is supported by two metal “spigots”, each located 12” inside a side edge of the panel (spaced 36” apart). The panel are secured in slots within the spigots, and the spigots are bolted to the supporting structure. The total height of the panel and spigots is 42”.

The dynamic testing involved hanging 300# sandbags against the side of the panel at the panel’s top edge. The sandbags were pulled back 33” and released, causing the sandbags to swing into the top of the panel, simulating a dynamic horizontal guardrail load – a person or object falling into the panel. The panel deflected approximately 4” and returned to its original shape, without experiencing any damage.

Don’t hesitate to contact us with questions about this testing or any other aspects of this evaluation program.

Sincerely,
American Engineering Testing, Inc.

A handwritten signature in black ink that reads 'Chris Hartnett'.

Chris Hartnett, PE
Principal Engineer
MN Lic. No. 42371
Phone: 651-647-2750
chartnett@amengtest.com



300 LB IMPACT TEST

This is an impact test of 60" x 39.37" x .53" thick CVGR Hercules tempered laminated glass panel mounted in two 316 solid core stainless steel spigots. Spigots are centered on glass 36" apart, 12" from end of glass. Plastic bags are weighted with 300 lbs of media, pulled back 36" from CVGR glass panel and then released to free fall to impact the top center of the CVGR panel. There is no damage or failure of the CVGR Hercules Glass panel or spigots from this 300 lb impact.

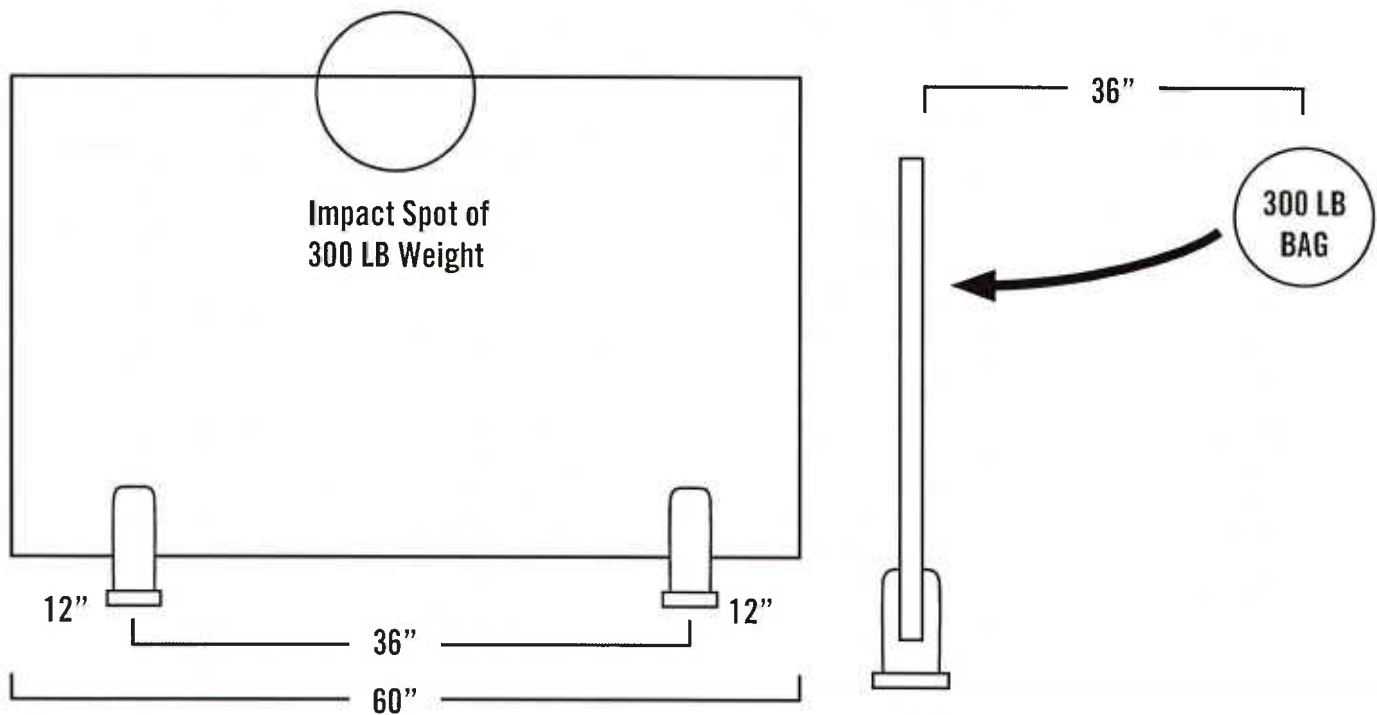

VIDEO STILLS ON REVERSE SIDE >

CVGR HERCULES GLASS 300 LB IMPACT TEST VIDEO STILLS

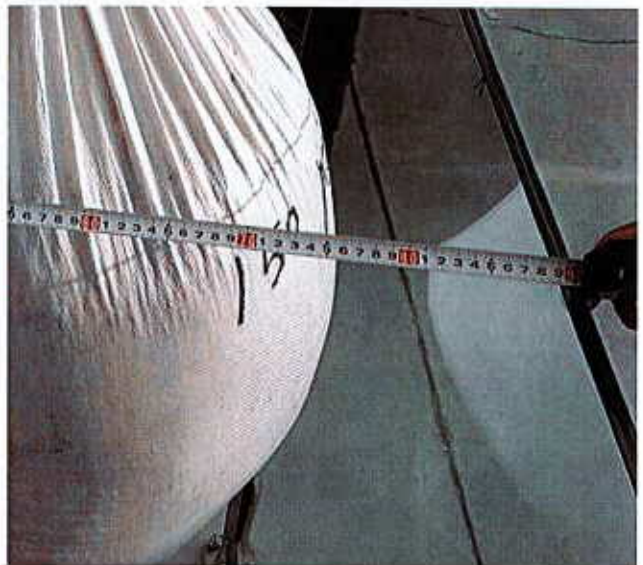
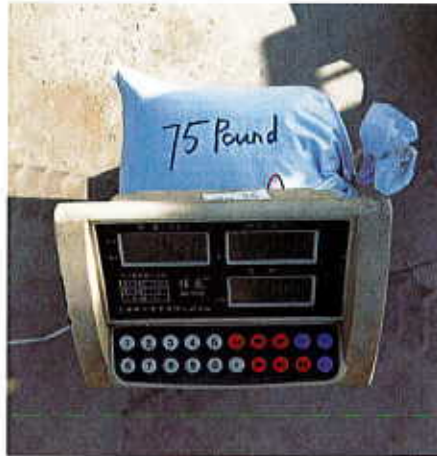



- CONSULTANTS
- ENVIRONMENTAL
- GEOTECHNICAL
- MATERIALS
- FORENSICS

November 13, 2020

Mr. John Ruprecht
Clear View Glass Railings
737 Quentin Avenue South
Lakeland, MN 55043

Re: Code Requirements & Static Test of Clear View Glass Railings “Hercules Glass” guardrail panel
AET Project #: 05-20608

Dear Mr. Ruprecht,

This letter reports building code requirements for guardrails; it also reports test methods and results for static tests performed on Clear View’s Hercules Glass panel.

The International Building Code (IBC) and International Residential Code (IRC) are “model codes” created by the International Code Council, intended to be used by states and municipalities as they publish their own building codes. Section 1607.8 of the IBC requires that “handrails and guards shall be designed to resist a linear load of 50 plf.” It also requires the system to resist a 200# concentrated load that produces the “maximum load effect” on any element within the system. The 2018 IRC Table R201.5 extends this requirement into residential construction. It is understood within the building design industry that lateral loads applied to the top of the panel create the maximum load effect; structural design assumes this loading condition.

Section 1607.8 of the IBC also refers to IBC section 2407 Glass in Handrails and Guards that adds a requirement for all-glass handrails and guards to “be laminated glass constructed of fully tempered or heat-strengthened glass”; this requirement was added in the 2015 IBC code cycle. Section 2407.1.1 adds the significant requirement: “a design factor of four shall be used for safety”. This addition bumps up the linear load to 200 plf and the concentrated load to 800#..

Exterior glass guardrail panels are designed to resist two load types: wind loads, and “live” loads such as a person or object pushing on or striking the panel from the side or from above. Wind loading on a panel can vary greatly based on location, terrain (wooded vs open) and elevation above ground; these are governed by publication ASCE 7 (American Society of Civil Engineers) Minimum Design Loads for Buildings and Other Structures. Wind speeds of 115 psf are used to calculate wind pressures against the glass, which generally vary from 17 psf (2nd story in wooded area) to 35 psf (30 stories tall in open terrain). The wind speeds required to match the stresses created by the 800# point load are 192 mph for the 42” tall panel and 215 mph for the 36” tall panel; these are only seen in a Category 5 hurricane or a tornado. Therefore, the 800# horizontal point load requirement is the worst-case scenario for the panels. Calculation methods to arrive at these values include computer modeling using finite element analysis,

using criteria specific to Clear View’s panels and support configuration.

Hercules Glass Testing

Testing was performed on the Hercules Glass panel by Clear View’s glass supplier, to simulate the forces created by 800# horizontal and vertical point loads on the panel (loads are not required to be simultaneous). The vertical load test is fairly straightforward and is shown in photo 1. Note: the intent was to load the panel to failure; however, the testers ran out of sandbags at 2,520 pounds, without failure.



Photo 1: Panel loaded vertically with 2,520 pounds.

Given the difficulty of pushing an 800# load horizontally against the panel, a test rig was set up that supports the panel on its side and places sandbags vertically on the panel. The panel is supported 28” from the top of panel (creating a 28” cantilever), with a heavy counterweight holding down the bottom of the panel mounted in its spigots. Sandbags were placed at the top edge of the panel until failure. See Diagram 1 and photo 2. The panel failed after one minute with 820 pounds loaded on its edge, which is equivalent to 547 pounds for a 42” tall panel. Using a finite element computer model, it was determined that the stresses caused by the 547 pound point load are equivalent to those caused by a 147 mph wind.

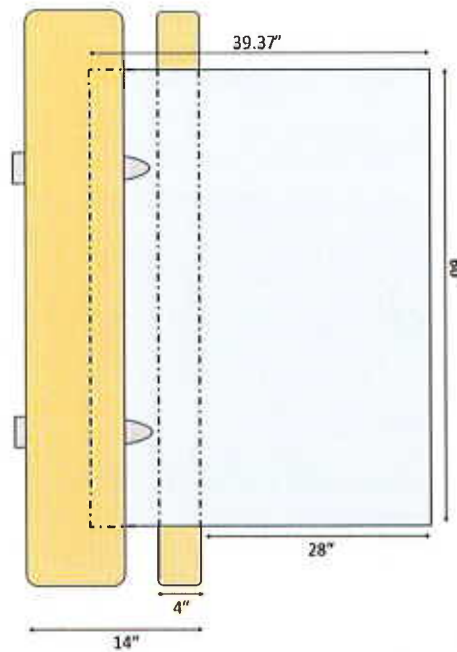

Diagram 1: Test rig lying on its side, looking from above, showing panel supported at 28 inches and at bottom of panel



Photo 2: Loading of panel with sandbags, simulating horizontal force

Due to the laminate construction of the panels (similar to a vehicle windshield), the panel broke into small pieces that were retained within the panel, preventing dangerous flying glass debris. See photo 3.



Photo 3: Panel after failure, showing all glass intact within laminate structure.

This test shows that the panel meets the intent to create a strong and safe barrier that can withstand reasonable loading (factor of safety of 2.5), and does not explode with dangerous glass shards during excessive loading.

Don't hesitate to contact us with questions about this testing or any other aspects of this evaluation program.

Sincerely,
American Engineering Testing, Inc.

Chris Hartnett, PE
Principal Engineer
MN Lic. No. 42371
Phone: 651-647-2750
chartnett@amengtest.com

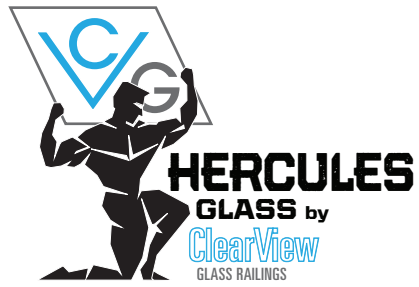

FLORIDA HURRICANE TESTING



CONSULTANTS
• ENVIRONMENTAL
• GEOTECHNICAL
• MATERIALS
• FORENSICS

November 17, 2020

Mr. John Ruprecht
Clear View Glass Railings
737 Quentin Avenue South
Lakeland, MN 55043

Re: Florida Wind Load Requirements for Wind-Borne Debris Regions, and Considerations for
“Hercules” Glass Guardrail Panel
AET Project #: 05-20608

Dear Mr. Ruprecht,

This letter reports the findings of our review of the Florida Building Code (FBC) wind requirements for Wind-Borne Regions, as defined by the FBC. We compare these requirements to the published and tested strength of the Hercules Glass Guardrail Panel, model CVGR 1001 FWP, and provide conclusions regarding panel design requirements to meet specific portions of the FBC code.

The Florida Building Code (FBC) Section 2407 addresses glass used in handrails and guards; it specifies materials, loads, support conditions and wind-borne debris regions. According to the FBC and in compliance with Category II of the Consumer Product Safety Commission (CPSC) and Class A of ANSI Z97.1, glass used in guardrails must be laminated glass constructed of fully tempered or heat strengthened glass and tested for its water penetration resistance, wind loading, impact, durability, thermal properties, and mechanical performance. It is our understanding that the panel is laminated and fully tempered. Our analysis addresses only the wind loading and impact requirements.

The FBC follows the International Building Code (IBC) requirements for wind loads, with ultimate (factored) wind speeds up to 180 mph; this is significantly higher than most areas within the United States. See the attached reference maps for determining the nominal ground wind speed from the Florida Building Code.

Our analysis converted the 180 mph required factored wind speed into a stress, using accepted analysis techniques, then compared this to the published (and tested) capacity of the panels. The American Society of Civil Engineers (ASCE) Standard 7-10, Chapter 29, provides the analysis method to convert wind speed (in mph) to pressure (in psf). Using Exposure Category C (open terrain) and a height of 100 feet above ground, a 180 mph factored wind produces a calculated pressure of 54 psf. This was plugged into a finite element model (FEM), using Risa-3D software (version 10.0.1), that models the 60” x 39” x 13mm tempered and laminated panels, supported on three “spigot” supports. The model generated a 5,500 psi principal axis stress (σ) in the panel.

The glass used in the panels has a published capacity of 10,000 psi tensile strength. Using the FEM, the pressure was increased until the capacity was reached, which was 100 psf. Plugging this into the ASCE 7-10 equations yields a service wind speed of 155 mph, or 250 mph factored wind speed. This is higher than the FBC's 180 mph factored wind speed requirement.

For building envelope glazing in wind-borne debris regions, glass that is part of a building envelope must be tested for impact resistance in accordance with American Society for Testing and Materials (ASTM) E1996. This requirement protects a closed building envelope from being penetrated and prevents high wind pressures from filling the building, potentially blowing out windows and lifting the roof off the building. Because these panels are not part of the building enclosure, damage from wind-borne debris would not penetrate the enclosure and its structural elements. Therefore, this test is not required for the panels used as a guardrail system.

FBC Section 2407.1.2 requires that all panels "shall be supported by a minimum of three glass balusters or shall be otherwise supported to remain in place should one baluster panel fail". We interpret this to mean that the panels will require three spigot supports, which is an increase from two supports in your standard panels. FBC Section 2407.1.2 also includes an exception that states, "A top rail shall not be required where the glass balusters are laminated glass with two or more glass plies of equal thickness and the same glass type when approved by the building official". We understand the panel meets this exception, so a top rail is not required.

In summary, based on our understanding of the FBC requirements, our conclusions are as follows:

1. Wind pressure – previous testing confirms that the panels meet the 180 mph factored wind speed requirement.
2. The panels do not require wind debris projectile testing.
3. Each panel requires three support points to the structure.
4. A top rail is not required for these panels.

Our calculations and computer model information and output is available upon request. Please call or e-mail us to discuss this analysis or any portion of the project to evaluate your panels.

Sincerely,
American Engineering Testing, Inc.



Chris Hartnett, PE*

Principal Engineer

*MN, WI, AL, MD, MO, NC, ND, OH, PA, TN VA

Phone: 651-647-2750

chartnett@amengtest.com

Mr. John Ruprecht – Clear View Glass Railings
AET Project No. 05-20608
November 17, 2020
Page 3 of 3

A handwritten signature in black ink, appearing to read "Daniel J. Larson". The signature is fluid and cursive, with a large initial "D" and "L".

Daniel J. Larson, PE
Principal Engineer
Florida License #70286
Phone: 651-659-1337
dlarson@amengtest.com

Attachment: FBC Section 1609.3 - Ultimate Design Wind Speed Map



STRUCTURAL ASSESSMENT FOR NORTH CAROLINA CODE OFFICIALS



CONSULTANTS

- ENVIRONMENTAL
- GEOTECHNICAL
- MATERIALS
- FORENSICS

CLEARVIEW GLASS RAILINGS – STRUCTURAL ASSESSMENT FOR NORTH CAROLINA CODE OFFICIALS

AET Project No. 05-20608

STRUCTURAL TESTING, FINITE ELEMENT
ANALYSIS AND CODE EVALUATION

MARCH 3, 2021

PREPARED FOR:
MR. JOHN RUPRECHT
CLEAR VIEW GLASS RAILINGS
737 QUENTIN AVENUE SOUTH
LAKELAND, MN 55043



St. Paul, MN
Duluth, MN
Mankato, MN
Marshall, MN
Rochester, MN
Williston, ND
Pierre, SD
Rapid City, SD
Sioux Falls, SD
Wausau, WI
Sheridan, WY
Gillette, WY
Casper, WY

PREPARED BY:
CHRIS HARTNETT, PE*

*MINNESOTA AND WISCONSIN



CONSULTANTS
• ENVIRONMENTAL
• GEOTECHNICAL
• MATERIALS
• FORENSICS

March 2, 2021

Mr. John Ruprecht
Clear View Glass Railings
737 Quentin Avenue South
Lakeland, MN 55043

Re: Wind Load Requirements for Wind-Borne Debris Regions, and Considerations for “Hercules”
Glass Guardrail Panel
AET Project #: 05-20608

Dear Mr. Ruprecht,

This letter reports the findings of our review of the North Carolina wind requirements for Wind-Borne Debris Regions, as described by North Carolina Building Code Section 1609. These requirements closely follow ASCE 7. We compare these requirements to the published and tested strength of the Hercules Glass Guardrail Panel, model CVGR 1001 FWP, and provide conclusions regarding panel design requirements to meet specific portions of the NCBC code.

Panel Construction

The North Carolina State Building Code (NCBC) Section 2407 addresses glass used in handrails and guards; it specifies materials, loads, support conditions and wind-borne debris regions. According to the NCBC and in compliance with Category II of the Consumer Product Safety Commission (CPSC) and Class A of ANSI Z97.1, glass used in guardrails must be laminated glass constructed of fully tempered or heat strengthened glass and tested for its water penetration resistance, wind loading, impact, durability, thermal properties, and mechanical performance. It is our understanding that the panel is laminated and fully tempered.

Panel Support

NCBC Section 2407.1.2 requires that all panels “shall be supported by a minimum of three glass balusters or shall be otherwise supported to remain in place should one baluster panel fail”. We interpret this to mean that the panels will require three spigot supports. The Hercules Glass Guardrail Panel is available with three spigots, where required by North Carolina Building Code.

The stainless steel spigots have been reviewed to confirm they possess the strength to support the shear and bending forces placed on them by the glass panels. When three spigots support the panels, they have sufficient capacity to resist wind loads required by the North Carolina Building Code. To meet the 4 * multiplier for live loads shown in 2015 IBC section 2407.1.1 (required by some municipalities) a

high strength cement is required between the glass and the spigot, to increase the friction coefficient and the spigot “gripping” strength of the panel.

The code-mandated wind and live load forces create an overturning force through the panels and spigots that is resisted by the supporting structure. Using the diagram provided by ClearView Glass Railings, showing 3.149” between two bolt holes between the spigot and the supporting structure, the hold down force for each bolt is 2,500#. A 3/8” diameter A354 structural bolt has sufficient capacity to resist this force. A review of the existing structure to support these loads is beyond the scope of this document, and is left for the project Structural Engineer of Record (SER) to certify.

NCBC Section 2407.1.2 includes an exception that states, “A top rail shall not be required where the glass balusters are laminated glass with two or more glass plies of equal thickness and the same glass type when approved by the building official”. We understand the panel meets this exception; therefore, a top rail is not required.

Wind Loading vs. Panel Capacity

The NCBC follows the International Building Code (IBC) requirements for wind loads, with ultimate (factored) wind speeds up to 160 mph. These panels were tested to 180 mph for wind loads across the Southeast US. Table 1609.3.1 converts this to 139 psf for unfactored loading, which was used in the analysis. See Attachment 1 for nominal ground wind speed reference maps from the North Carolina Building Code.

The American Society of Civil Engineers (ASCE) Standard 7-10, Chapter 29, provides the analysis method to convert wind speed (in mph) to pressure (psf) against the glass panel. Using Exposure Category C (open terrain) and a height of 100 feet above ground; a 139 mph wind produces a calculated pressure of 81psf. See Attachment 2. The three distinct support points, “spigots”, for these panels creates stress concentrations around the supports that are best modeled using a finite element model (FEM). A FEM model was created for this panel using Risa-3D software (version 10.0.1), that modeled a 60” wide x 39” tall x 13mm thick tempered and laminated panel, with a 81psf surface load applied. The model generated a 15,979 psi principal axis stress (σ) in the panel. See Attachment 3.

The glass used in the panels was tested to determine its structural capacity, using a static load applied to a test specimen. The specimen was loaded to failure, and the loading was applied to the FEM to determine the equivalent stresses. The failure stress was 35,767 psi. This modeling shows that the panels have calculated factor-of-safety of 2.24. See Attachment 4.

Impact Resistance

For building envelope glazing in wind-borne debris regions, glass that is part of a building envelope must be tested for impact resistance in accordance with American Society for Testing and Materials (ASTM) E1996. This requirement protects a closed building envelope from being penetrated and prevents high wind pressures from filling the building, potentially blowing out windows and lifting the roof off the building. Because these panels are not part of the building enclosure, damage from wind-

Mr. John Ruprecht – Clear View Glass Railings
AET Project No. 05-20608
March 2, 2021
Page 3 of 3

borne debris would not penetrate the enclosure and its structural elements. Therefore, this test is not required for the panels used as a guardrail system.

Summary

Based on our understanding of the NCBC requirements, our conclusions follow:

1. Each panel is constructed of fully tempered, laminated glass.
2. Each panel is secured to the structure with three supports.
3. A top rail is not required for these panels.
4. Wind pressure – previous testing confirms that the panels meet the 180 mph factored wind speed requirement, with a calculated factor-of-safety of 2.24.
5. The panels do not require wind debris projectile testing.

Please call or e-mail us to discuss this analysis or any portion of the project to evaluate your panels.

Sincerely,
American Engineering Testing, Inc.



Chris Hartnett, PE*

Principal Engineer

*MN, WI

Phone: 651-647-2750

chartnett@amengtest.com

Attachment: Testing and Code Evaluation

- 1: North Carolina Figure 1609.1 – Ultimate Wind Design Speed.
- 2: ASCE 7-10 Wind & Pressure Calculations.
3. Finite Element Modelling.
- 4: Physical Testing

1609.3 Ultimate Design Wind Speed

The ultimate design wind speed, V_{ult} , in mph, for the determination of the wind loads shall be determined by Figures 1609.3(1), 1609.3(2) and 1609.3(3). The ultimate design wind speed, V_{ult} , for use in the design of Risk Category II buildings and structures shall be obtained from Figure 1609.3(1). The ultimate design wind speed, V_{ult} , for use in the design of Risk Category III and IV buildings and structures shall be obtained from Figure 1609.3(2). The ultimate design wind speed, V_{ult} , for use in the design of Risk Category I buildings and structures shall be obtained from Figure 1609.3(3). The ultimate design wind speed, V_{ult} , for the special wind regions indicated near mountainous terrain and near gorges shall be in accordance with local jurisdiction requirements. The ultimate design wind speeds, V_{ult} , determined by the local jurisdiction shall be in accordance with Section 26.5.1 of ASCE 7. The exact location of wind speed lines shall be established by local ordinance using recognized physical landmarks such as major roads, canals, rivers and lake shores wherever possible.

In nonhurricane-prone regions, when the ultimate design wind speed, V_{ult} , is estimated from regional climatic data, the ultimate design wind speed, V_{ult} , shall be determined in accordance with Section 26.5.3 of ASCE 7.

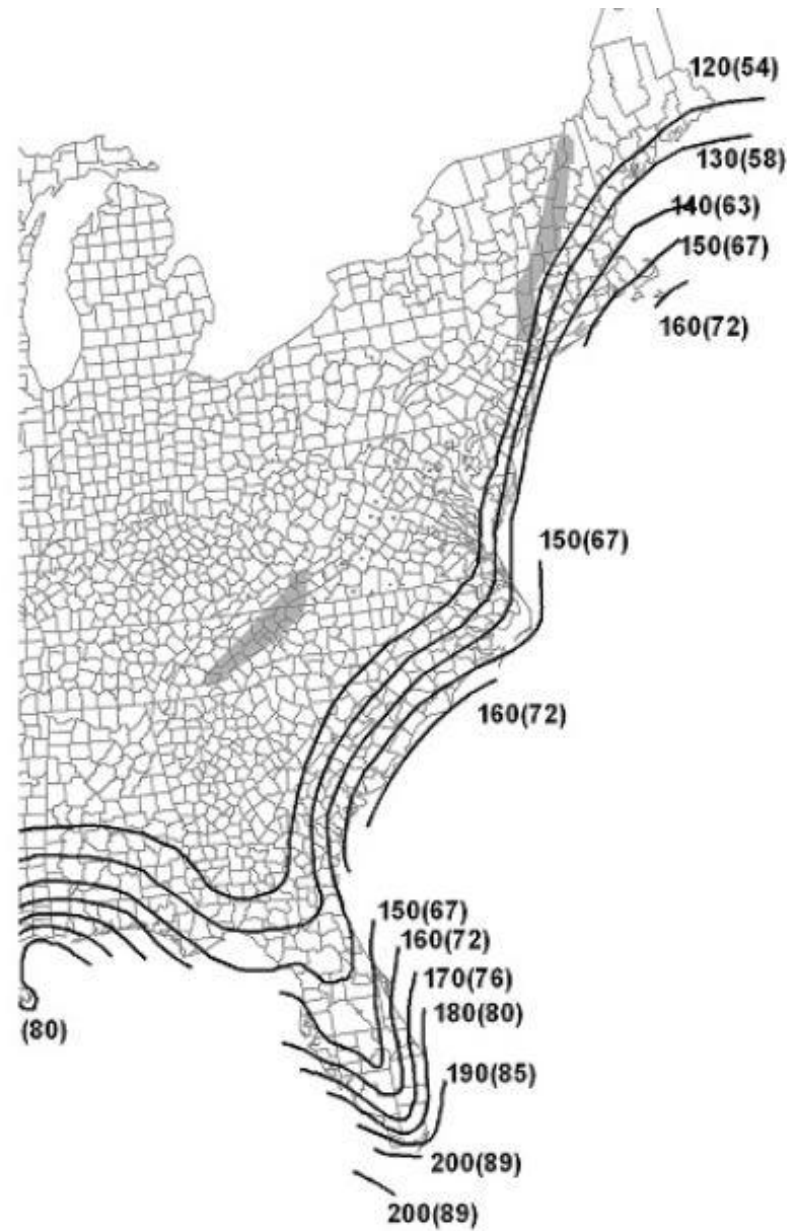

Notes:

1. Values are nominal design 3-second gust wind speeds in miles per hour (m/s) at 33 ft (10 m) above ground for Exposure C category.
2. Linear interpolation between contours is permitted.
3. Islands and coastal areas outside the last contour shall use the last wind speed contour of the coastal area.
4. Mountainous terrain, gorges, ocean promontories, and special wind regions shall be examined for unusual wind conditions.
5. Wind speeds correspond to approximately a 7% probability of exceedance in 50 years (Annual Exceedance Probability = 0.00143, MRI = 700 Years).
6. Location-specific basic wind speeds shall be permitted to be determined using www.atcouncil.org/windspeed.

FIGURE 1609.3(1) ULTIMATE DESIGN WIND SPEEDS, V_{ult} , FOR RISK CATEGORY II BUILDINGS AND OTHER STRUCTURES

Attachment 1

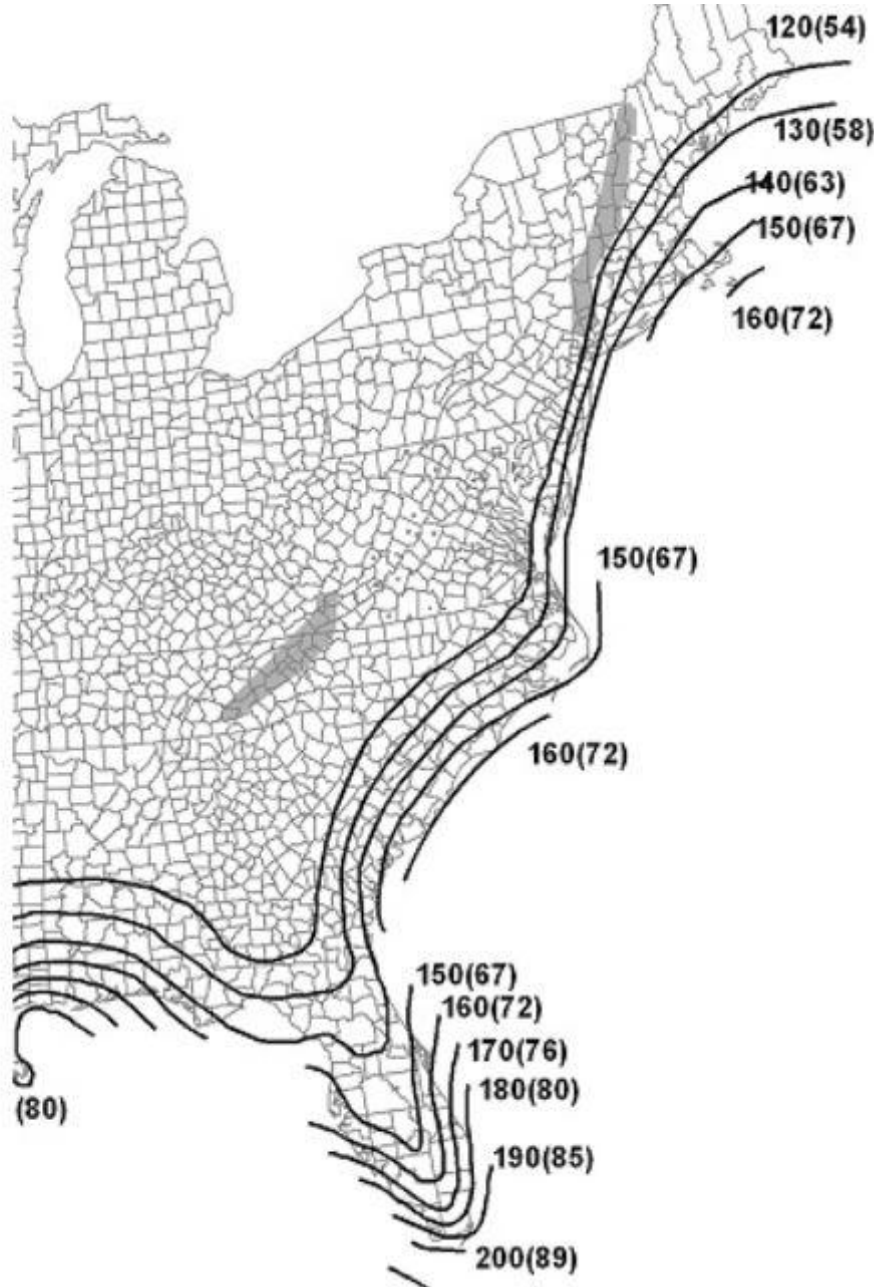

ULTIMATE DESIGN WIND SPEEDS, V_{ULT} , FOR RISK CATEGORY III AND IV BUILDINGS AND OTHER STRUCTURES

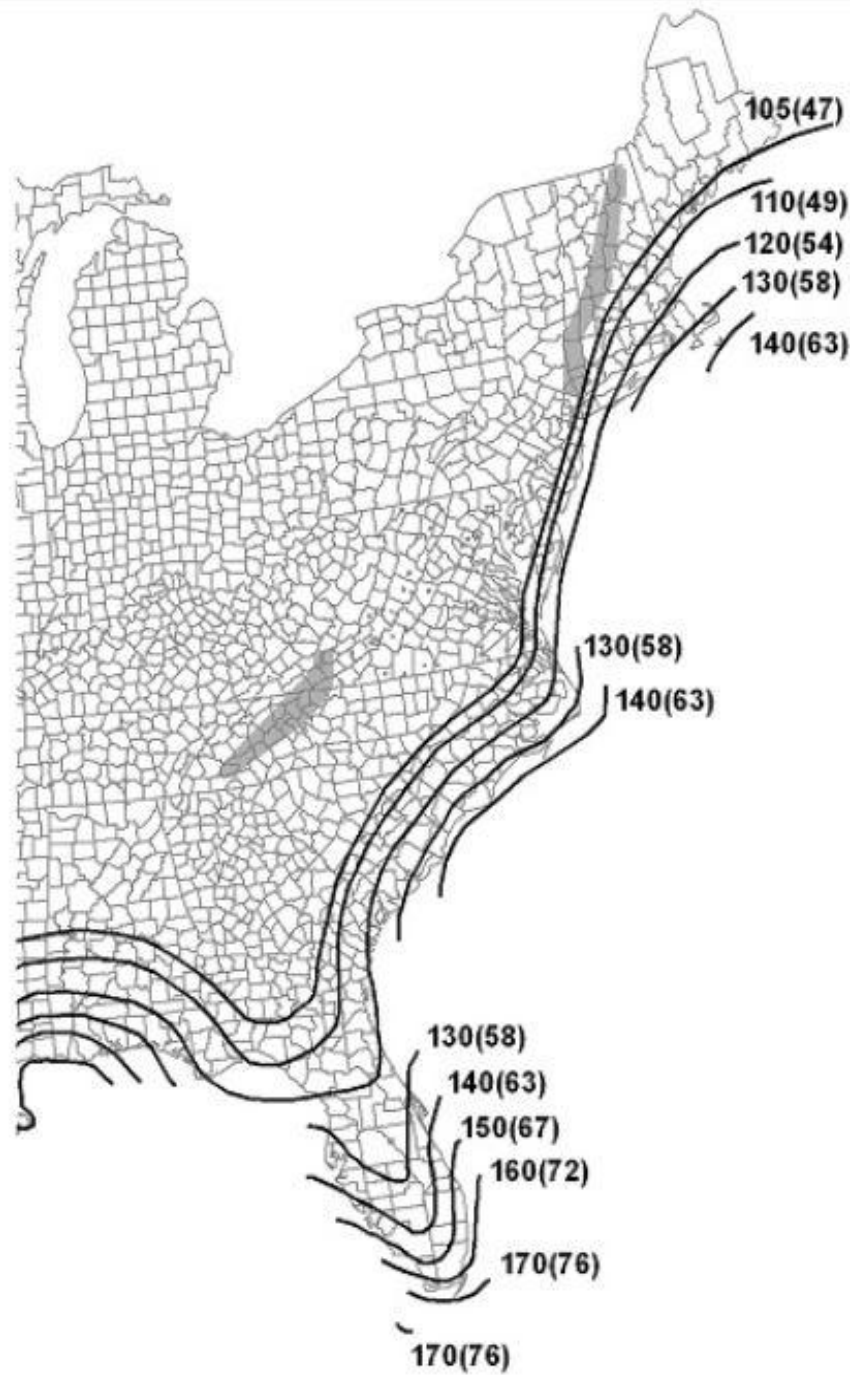

ULTIMATE DESIGN WIND SPEEDS, V_{ULT} , FOR RISK CATEGORY I BUILDINGS AND OTHER STRUCTURES

When required, the ultimate design wind speeds of Figures 1609.3(1), 1609.3(2) and 1609.3(3) shall be converted to nominal design wind speeds, V_{asd} , using Table 1609.3.1 or Equation 16-33.

$$V_{asd} = V_{ult} \sqrt{0.6}$$

where:

(Equation 16-33)

V_{asd} = Nominal design wind speed applicable to methods specified in Exceptions 4 and 5 of Section 1609.1.1.

V_{ult} = Ultimate design wind speeds determined from Figures 1609.3(1), 1609.3(2) or 1609.3(3).

TABLE 1609.3.1

V_{ult}	100	110	120	130	140	150	160	170	180	190	200
V_{asd}	78	85	93	101	108	116	124	132	139	147	155

For SI: 1 mile per hour = 0.44 m/s.

- Linear interpolation is permitted.
- V_{asd} = nominal design wind speed applicable to methods specified in Exceptions 1 through 5 of Section 1609.1.1.
- V_{ult} = ultimate design wind speeds determined from Figure 1609.3(1), 1609.3(2) or 1609.3(3).

Attachment 1

Attachment 2: Wind Loading Calculation

IBC Wind Load Calculations

Project: CVG Railings - North Carolina High Wind Region
 Project #: 05-20608
 11/5/2020
 Code: North Carolina Building Code
 Source Document: ASCE 7-10, Chapter 29

Other Structures (Section 6.5.13)

Coefficients								
<u>Coefficient</u>	<u>value</u>	<u>source</u>						
Risk Category	ii	Table 1.5-1						
V (mph):	139	Figures 26.5-1A-C. All of US e:						
Exposure:	c	para 26.7						
direction factor, Kd:	0.85	Table 26.6-1						
topography fact , Kzt	1	para 26.8						
gust factor, G	0.85	Section 26.9						
Larger dimension of sign, M (ft)	5	Table 6-11						
Smaller dimension of sign, N (ft)	3	Table 6-11						
Net force coefficients, Cf	1.8	Figure 29.4-1 through 29.5-3						
Average height above ground, (ft)	100							
velocity pres. Expose coeff, Kz		Table 29.3-1						
Building height (ft):								
0-15	0.85							
20	0.9							
25	0.94							
30	0.98							
40	1.04							
50	1.09							
60	1.13							
70	1.17							
80	1.21							
90	1.24							
100	1.26	Kh (K @ mean roof ht						
velocity pres. Expose coeff, Kh	1.26	Choose highest value of Kz						
Velocity pressure, qz	52.97	$qz = .00256 * Kz * Kzt * Kd * V^2$						
Projected area normal to wind, Af (sq ft)	15	$= M * N$						
<table> <tr> <td>Total Force on Supports, F (kips)</td> <td>1.22</td> <td>$F = qz * G * Cf * Af$</td> </tr> <tr> <td>Equivalent pressure, P (psf)</td> <td>81.0</td> <td>$P = F / (M * N)$</td> </tr> </table>			Total Force on Supports, F (kips)	1.22	$F = qz * G * Cf * Af$	Equivalent pressure, P (psf)	81.0	$P = F / (M * N)$
Total Force on Supports, F (kips)	1.22	$F = qz * G * Cf * Af$						
Equivalent pressure, P (psf)	81.0	$P = F / (M * N)$						

Attachment 3: Finite Element Modelling

A finite-element-model (FEM) was created to model the Hercules Glass Panel. The model measures 60" x 39" x 13mm (0.51") thick, and includes 960 elements sized approximately 1.5" square x 13mm (0.51") thick. The model is supported at three points, at the panel "spigots. The spigots are approximately 4" tall x 3" wide. See Figure 1 below.

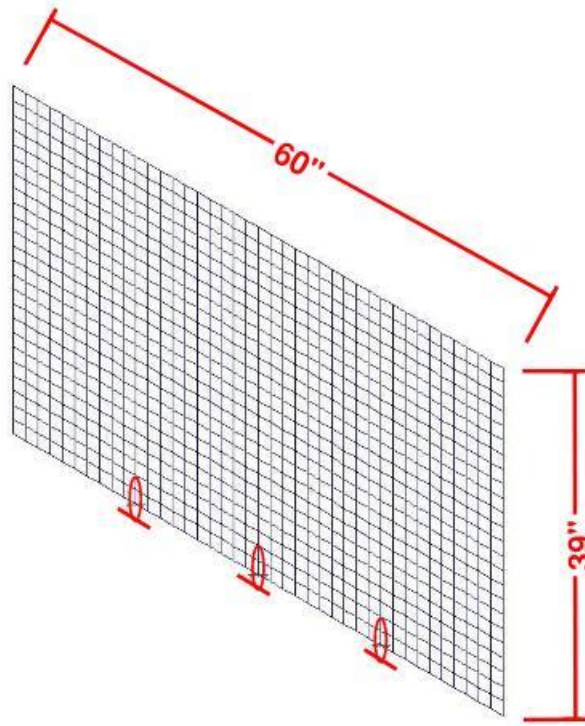

Figure 1: Panel Configuration

The highest stresses caused by a lateral wind load are experienced at the elements around the spigots. Figure 2 shows the element numbers of the panel and a close-up of the elements around the spigots. Note that the elements supported directly by the spigots are blanked out because they are supported by the spigots and are not stressed.

<u>Left spigot</u>	<u>Middle spigot</u>	<u>Right spigot</u>
Element 899	919	939
897	917	937
819	839	859
820	840	860
823	842	863
824	844	864
902	922	942
904	924	944

Attachment 3: Finite Element Modelling

1	2	5	6	9	10	13	14	17	18	21	22	25	26	29	30	33	34	37	38	41	42	45	46	49	50	53	54	57	58	61	62	65	66	69	70	73	74	77	78
3	4	7	8	11	12	15	16	19	20	23	24	27	28	31	32	35	36	39	40	43	44	47	48	51	52	55	56	59	60	63	64	67	68	71	72	75	76	79	80
81	82	85	86	89	90	93	94	97	98	101	102	105	106	109	110	113	114	117	118	121	122	125	126	129	130	133	134	137	138	141	142	145	146	149	150	153	154	157	158
83	84	87	88	91	92	95	96	99	100	103	104	107	108	111	112	115	116	119	120	123	124	127	128	131	132	135	136	139	140	143	144	147	148	151	152	155	156	159	160
161	162	165	166	169	170	173	174	177	178	181	182	185	186	189	190	193	194	197	198	201	202	205	206	209	210	213	214	217	218	221	222	225	226	229	230	233	234	237	238
163	164	167	168	171	172	175	176	179	180	183	184	187	188	191	192	195	196	199	200	203	204	207	208	211	212	215	216	219	220	223	224	227	228	231	232	235	236	239	240
241	242	245	246	249	250	253	254	257	258	261	262	265	266	269	270	273	274	277	278	281	282	285	286	289	290	293	294	297	298	301	302	305	306	309	310	313	314	317	318
243	244	247	248	251	252	255	256	259	260	263	264	267	268	271	272	275	276	279	280	283	284	287	288	291	292	295	296	299	300	303	304	307	308	311	312	315	316	319	320
321	322	325	326	329	330	333	334	337	338	341	342	345	346	349	350	353	354	357	358	361	362	365	366	369	370	373	374	377	378	381	382	385	386	389	390	393	394	397	398
323	324	327	328	331	332	335	336	339	340	343	344	347	348	351	352	355	356	359	360	363	364	367	368	371	372	375	376	379	380	383	384	387	388	391	392	395	396	399	400
401	402	405	406	409	410	413	414	417	418	421	422	425	426	429	430	433	434	437	438	441	442	445	446	449	450	453	454	457	458	461	462	465	466	469	470	473	474	477	478
403	404	407	408	411	412	415	416	419	420	423	424	427	428	431	432	435	436	439	440	443	444	447	448	451	452	455	456	459	460	463	464	467	468	471	472	475	476	479	480
481	482	485	486	489	490	493	494	497	498	501	502	505	506	509	510	513	514	517	518	521	522	525	526	529	530	533	534	537	538	541	542	545	546	549	550	553	554	557	558
483	484	487	488	491	492	495	496	499	500	503	504	507	508	511	512	515	516	519	520	523	524	527	528	531	532	535	536	539	540	543	544	547	548	551	552	555	556	559	560
561	562	565	566	569	570	573	574	577	578	581	582	585	586	589	590	593	594	597	598	601	602	605	606	609	610	613	614	617	618	621	622	625	626	629	630	633	634	637	638
563	564	567	568	571	572	575	576	579	580	583	584	587	588	591	592	595	596	599	600	603	604	607	608	611	612	615	616	619	620	623	624	627	628	631	632	635	636	639	640
641	642	645	646	649	650	653	654	657	658	661	662	665	666	669	670	673	674	677	678	681	682	685	686	689	690	693	694	697	698	701	702	705	706	709	710	713	714	717	718
643	644	647	648	651	652	655	656	659	660	663	664	667	668	671	672	675	676	679	680	683	684	687	688	691	692	695	696	699	700	703	704	707	708	711	712	715	716	719	720
721	722	725	726	729	730	733	734	737	738	741	742	745	746	749	750	753	754	757	758	761	762	765	766	769	770	773	774	777	778	781	782	785	786	789	790	793	794	797	798
723	724	727	728	731	732	735	736	739	740	743	744	747	748	751	752	755	756	759	760	763	764	767	768	771	772	775	776	779	780	783	784	787	788	791	792	795	796	799	800
801	802	805	806	809	810	813	814	817	818	821	822	825	826	829	830	833	834	837	838	841	842	845	846	849	850	853	854	857	858	861	862	865	866	869	870	873	874	877	878
803	804	807	808	811	812	815	816	819	820	823	824	827	828	831	832	835	836	839	840	843	844	847	848	851	852	855	856	859	860	863	864	867	868	871	872	875	876	879	880
881	882	885	886	889	890	893	894	897	898	901	902	905	906	909	910	913	914	917	918	921	922	925	926	929	930	933	934	937	938	941	942	945	946	949	950	953	954	957	958
883	884	887	888	891	892	895	896	899	900	903	904	907	908	911	912	915	916	919	920	923	924	927	928	931	932	935	936	939	940	943	944	947	948	951	952	955	956	959	960

Figure 2: Element numbering – full panel and close-up of elements surrounding three spigots

Two load cases were run to estimate the stresses surrounding the spigot:

1. An 81 psf wind load that is equivalent to a 139 mph unfactored load (180 psf factored load). Figure 3;
2. The loading-to-failure test: 820# loaded at 42" above the spigots (see attachment 4 for an explanation of this). Figure 4.

The wind load created a surface tensile stress (σ , pulling the face of the glass apart, which is the failure mechanism for a brittle material) of 15,979 psi. See Figure 3. The test-to-failure created tensile stress of 35,767 psi. This shows the panel has a factor of safety of 2.24 against failure due to Florida's highest winds of 180 mph (factored). See Figure 4.

The FEM model is available for review, upon request.

Attachment 3: Finite Element Modelling

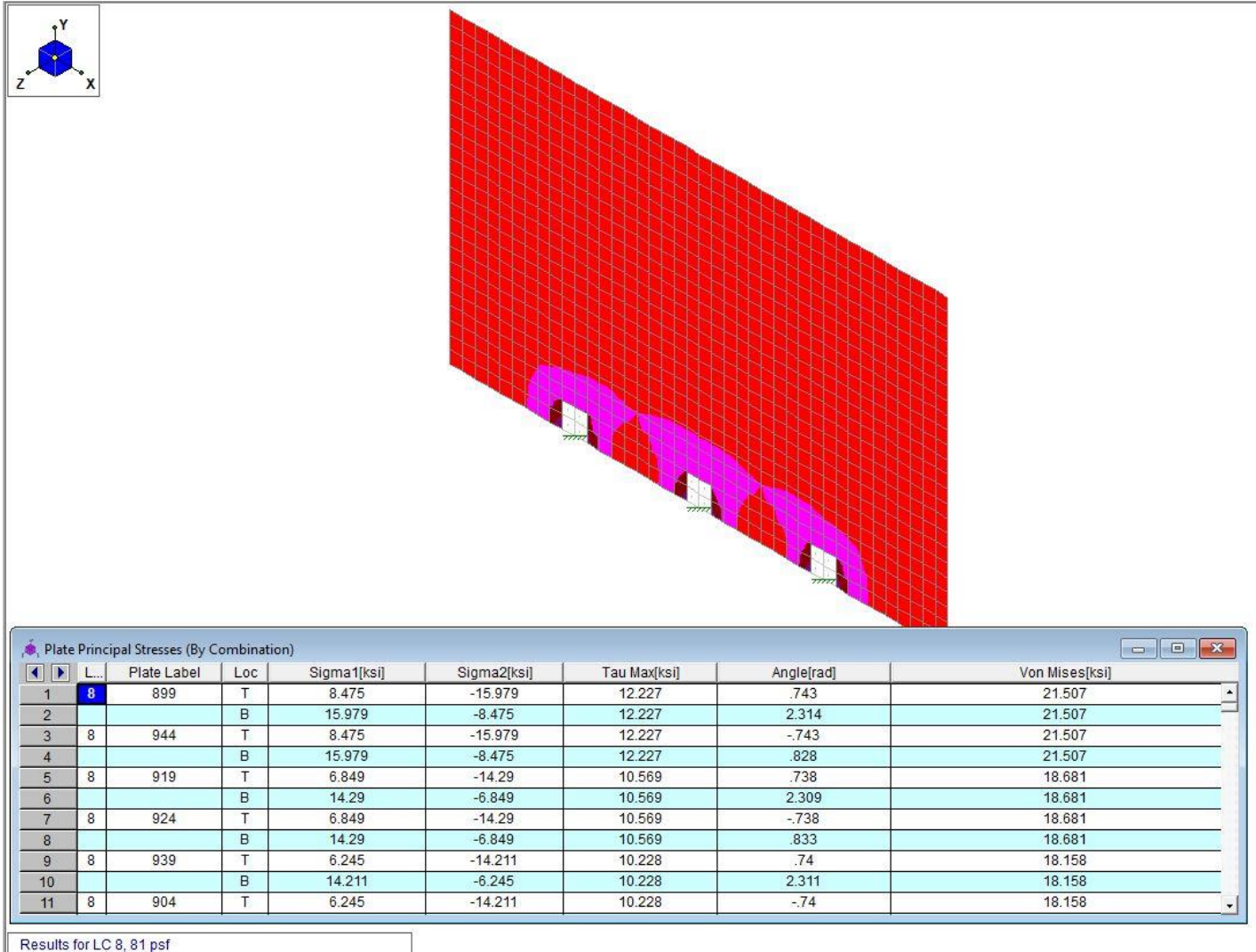
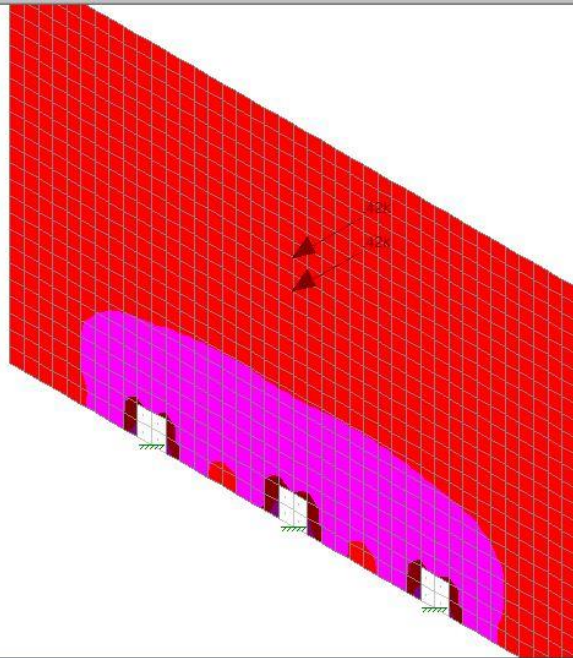

Figure 3: Stresses due to 81 psf (180 mph factored winds)

Attachment 3: Finite Element Modelling



	L...	Plate Label	Loc	Sigma1[ksi]	Sigma2[ksi]	Tau Max[ksi]	Angle[rad]	Von Mises[ksi]
1	5	943	T	8.444	-35.767	22.106	-.277	40.653
2			B	35.767	-8.444	22.106	1.293	40.653
3	5	900	T	8.444	-35.767	22.106	.277	40.653
4			B	35.767	-8.444	22.106	1.848	40.653
5	5	899	T	8.435	-12.214	10.324	.676	17.982
6			B	12.214	-8.435	10.324	2.247	17.982
7	5	944	T	8.435	-12.214	10.324	-.676	17.982
8			B	12.214	-8.435	10.324	.895	17.982
9	5	939	T	6.371	-11.874	9.122	.724	16.038
10			B	11.874	-6.371	9.122	2.295	16.038
11	5	904	T	6.371	-11.874	9.122	-.724	16.038

Loads: BLC 5, 820#@28"
Results for LC 5, 820@28"

Figure 4: Stresses due to failure load (820 psf @ 28")

Attachment 4: Physical Testing

July 13, 2020

Building Code Requirements

The International Building Code (IBC) and International Residential Code (IRC) are “model codes” created by the International Code Council, intended to be used by states and municipalities as they publish their own building codes. Section 1607.8 of the IBC requires that “handrails and guards shall be designed to resist a linear load of 50 plf.” It also requires the system to resist a 200# concentrated load that produces the “maximum load effect” on any element within the system. The 2018 IRC Table R201.5 extends this requirement into residential construction. It is understood within the building design industry that loads applied to the top of the panel create the maximum load effect; structural design assumes this loading condition.

Section 1607.8 of the IBC also refers to IBC section 2407 that adds a requirement for all-glass handrails and guards to “be laminated glass constructed of fully tempered or heat-strengthened glass”; this requirement was added in the 2015 IBC code cycle. Section 2407.1.1 adds the significant requirement: “a design factor of four shall be used for safety”. This addition bumps up the linear load to 200 plf and the concentrated load to 800#. Presumably, this is intended to prevent the glass from shattering and injuring people below.

Exterior glass guardrail panels are designed to resist two load types: wind loads, and “live” loads such as a person or object pushing on or striking the panel from the side or from above. Wind loading on a panel can vary greatly based on location, terrain (wooded vs open) and elevation above ground; these are governed by publication ASCE 7 (American Society of Civil Engineers Minimum Design Loads for Buildings and Other Structures). Wind speeds of 115 psf are used to calculate wind pressures against the glass, which generally vary from 17 psf (2nd story in wooded area) to 35 psf (30 stories tall in open terrain). The wind speeds required to match the stresses created by the 800# point load are 192 mph for the 42” tall panel and 215 mph for the 36” tall panel; these are only seen in a Category 5 hurricane or a tornado. Therefore, the 800# horizontal point load is the worst-case scenario for the panels. Note: panel design in “high wind” regions such as the coastal Southeast US are designed to resist flying debris and are subject to different loading requirements. Calculation methods to arrive at these values include computer modeling using finite element analysis; criteria specific to Clear View’s panels and support configuration were used.

Hercules Glass Testing

Testing was performed on the Hercules Glass panel by Clear View’s glass supplier, to simulate the forces created by 800# horizontal and vertical point loads on the panel (loads are not required to be simultaneous). The vertical load test is straightforward and is shown in photo 1. Note: the intent was to load the panel to failure; however, the testers ran out of sandbags at 2,520 pounds, without failure. Given the difficulty of pushing an 800# load horizontally against the panel, a test rig was set up that supports the panel on its side and places sandbags vertically on the panel. The panel is supported 28” from the top of panel (creating a 28” cantilever), with a heavy counterweight holding down the bottom of the panel mounted in its spigots. Sandbags were placed at the top edge of the panel until failure. See Diagram 1 and photo 2. The panel failed after one minute with 820 pounds loaded on its edge, which is equivalent to 547 pounds for a 42” tall panel. Due to the laminate construction of the panels (similar to a vehicle windshield), the panel broke into small pieces that were retained within the panel, preventing

Attachment 4: Physical Testing

dangerous flying glass debris. See photo 3. This test shows that the panel meets the intent to create a strong and safe barrier that can withstand reasonable loading (factor of safety of 2.5), and does not explode with dangerous glass shards during excessive loading.



Photo 1: Panel loaded vertically with 2,520 pounds.



Photo 2: Loading of panel with sandbags, simulating horizontal force

Attachment 4: Physical Testing

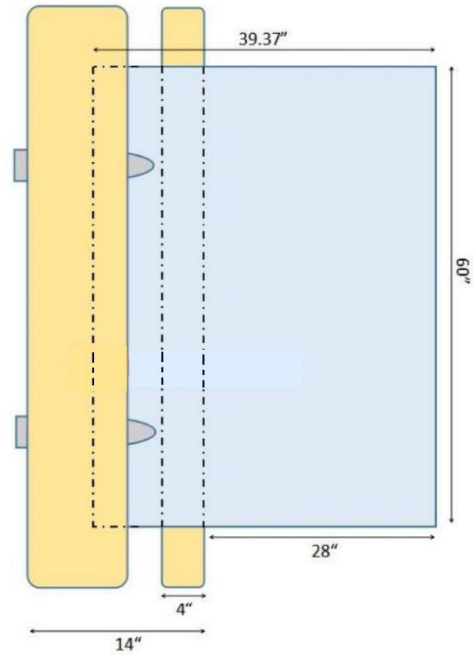

Diagram 1: Test rig lying on its side, looking from above, showing panel supported at 28" and at bottom of panel



Photo 3: Panel after failure, showing all glass intact within laminate structure.



FLORIDA AND MIAMI DADE COUNTY NOA DATA



January 28, 2021

Mr. Chris Frederick
Product Control Section
Department of Regulatory and Economic Resources
Miami-Dade County
11805 S. W. 26 Street, Room 208
Miami, Florida, 33175-2474

Re: ClearView Glass Railings – Request for Notice of Acceptance (NOA) for Hercules Glass Panels

Dear Mr. Frederick,

This letter is written to request a Notice of Acceptance (NOA) for our Hercules Glass Panels product. This is a request for a NOA for a new product. Our Hercules Glass Panels are sold as interior and exterior glass railings, to be installed on commercial and residential buildings as guardrails. They meet Florida Building Code requirements for guardrails, including special requirements for all-glass railings. The panels have been tested and evaluated to withstand the 180 mph winds in the high wind coastal area.

Included in this submittal packet:

1. Application
2. Application review fee
3. Indication of labeling to meet Miami-Dade County Labeling Guideline.
4. Signed letter by Florida Licensed PE stating that the produce conforms to current FBC.
5. Signed letter by same Florida PE that he has no financial interest with the lab that performed the test or the product supplier.
6. Packet signed by Florida PE that includes evaluation of FBC requirements, testing data, and structural analysis of testing results.
7. Marked-up drawing identifying all components of specimens.

Sincerely,

John Ruprecht



CONSULTANTS
· ENVIRONMENTAL
· GEOTECHNICAL
· MATERIALS
· FORENSICS

Attachment 4

February 1, 2021

Mr. Chris Frederick
Product Control Section
Department of Regulatory and Economic Resources
Miami-Dade County
11805 Southwest 26th St.
Miami, FL 33175

Re: ClearView Glass Railings – Florida Code Review
AET Project #: 05-20608

Dear Mr. Frederick,

This letter provides our statement regarding the Hercules Glass Panel, produced by ClearView Glass Railings of Lakeland, Minnesota, conformance to the Florida State Building Code relative to Sections 1607 and 1609 for exterior guardrails and more specifically, all-glass guardrails. Our scope included reviewing physical testing performed by others and performing our own stress calculations using Finite Element Analysis methods. Based on our analysis and to the best of our knowledge, it is our opinion that the Hercules Glass Panels meet the applicable sections of the Florida State Building Code. This letter is accompanied by a packet of information that describes our services with this product.

Contact us for additional information or with questions that you might have.

Sincerely,
American Engineering Testing, Inc.

A handwritten signature in black ink that reads 'Chris Hartnett'.

Chris Hartnett, PE*
Principal Engineer
*MN, WI, AL, MD, MO, NC, ND, OH, PA, TN VA
Phone: 651-647-2750
chartnett@amengtest.com

A handwritten signature in black ink that reads 'Daniel J. Larson'.

Daniel J. Larson, PE
Principal Engineer
Florida License #70286
Phone: 651-659-1337
dlarson@amengtest.com



CONSULTANTS
• ENVIRONMENTAL
• GEOTECHNICAL
• MATERIALS
• FORENSICS

Attachment 5

February 1, 2021

Department of Regulatory and Economic Resources – Product Control Section
Miami-Dade County
Stephen P. Clark Center
111 NW 1st St.
Miami, FL 33128

Re: “Hercules” Glass Guardrail Panel Testing – Statement of Non-Financial Interest
AET Project #: 05-20608

Dear Product Control Section,

This letter is written to support the application for a Notice of Acceptance (NOA) by Miami-Dade County, for Clear View Glass Railings (CVG) “Hercules” Glass Guardrail Panel. American Engineering Testing (AET) has been engaged by CVG to provide structural testing and engineering consulting services to address International Building Code (IBC) and Florida Building Code (FBC) requirements.

American Consulting Services and all subsidiaries including AET, officers and staff working on this project, have no financial interest in CVG or their products.

Sincerely,
American Engineering Testing, Inc.

A handwritten signature in black ink that reads 'Chris Hartnett'.

Chris Hartnett, PE*
Principal Engineer
*MN, WI, AL, MD, MO, NC, ND, OH, PA, TN VA
Phone: 651-647-2750
chartnett@amengtest.com

A handwritten signature in black ink that reads 'Daniel J. Larson'.

Daniel J. Larson, PE
Principal Engineer
Florida License #70286
Phone: 651-659-1337
dlarson@amengtest.com



CONSULTANTS

- ENVIRONMENTAL
- GEOTECHNICAL
- MATERIALS
- FORENSICS

CLEARVIEW GLASS RAILINGS –
STRUCTURAL ASSESSMENT
FOR MIAMI-DADE COUNTY NOTICE OF
ACCEPTANCE (NOA)

AET Project No. 05-20608

STRUCTURAL TESTING, FINITE ELEMENT
ANALYSIS AND CODE EVALUATION

JANUARY 28, 2021

PREPARED FOR:
MR. JOHN RUPRECHT
CLEAR VIEW GLASS RAILINGS
737 QUENTIN AVENUE SOUTH
LAKELAND, MN 55043



St. Paul, MN
Duluth, MN
Mankato, MN
Marshall, MN
Rochester, MN
Williston, ND
Pierre, SD
Rapid City, SD
Sioux Falls, SD
Wausau, WI
Sheridan, WY
Gillette, WY
Casper, WY

PREPARED BY:
CHRIS HARTNETT, PE
DANIEL LARSON, PE



CONSULTANTS
• ENVIRONMENTAL
• GEOTECHNICAL
• MATERIALS
• FORENSICS

Attachment 6

February 1, 2021

Mr. John Ruprecht
Clear View Glass Railings
737 Quentin Avenue South
Lakeville, MN 55043

Re: Florida Wind Load Requirements for Wind-Borne Debris Regions, and Considerations for
“Hercules” Glass Guardrail Panel
AET Project #: 05-20608

Dear Mr. Ruprecht,

This letter reports the findings of our review of the Florida Building Code (FBC) wind requirements for Wind-Borne Regions, as defined by the FBC. We compare these requirements to the published and tested strength of the Hercules Glass Guardrail Panel, model CVGR 1001 FWP, and provide conclusions regarding panel design requirements to meet specific portions of the FBC code.

Panel Construction

The Florida Building Code (FBC) Section 2407 addresses glass used in handrails and guards; it specifies materials, loads, support conditions and wind-borne debris regions. According to the FBC and in compliance with Category II of the Consumer Product Safety Commission (CPSC) and Class A of ANSI Z97.1, glass used in guardrails must be laminated glass constructed of fully tempered or heat strengthened glass and tested for its water penetration resistance, wind loading, impact, durability, thermal properties, and mechanical performance. It is our understanding that the panel is laminated and fully tempered.

Panel Support

FBC Section 2407.1.2 requires that all panels “shall be supported by a minimum of three glass balusters or shall be otherwise supported to remain in place should one baluster panel fail”. We interpret this to mean that the panels will require three spigot supports. The Hercules Glass Guardrail Panel is available with three spigots, where required by Florida Building Code.

FBC Section 2407.1.2 also includes an exception that states, “A top rail shall not be required where the glass balusters are laminated glass with two or more glass plies of equal thickness and the same glass type when approved by the building official”. We understand the panel meets this exception; therefore, a top rail is not required.

Wind Loading vs. Panel Capacity

The FBC follows the International Building Code (IBC) requirements for wind loads, with ultimate (factored) wind speeds up to 180 mph; Table 1609.3.1 converts this to 139 psf for unfactored loading, which was used in the analysis. See Attachment 1 for nominal ground wind speed reference maps from the Florida Building Code.

The American Society of Civil Engineers (ASCE) Standard 7-10, Chapter 29, provides the analysis method to convert wind speed (in mph) to pressure (psf) against the glass panel. Using Exposure Category C (open terrain) and a height of 100 feet above ground; a 139 mph wind produces a calculated pressure of 81psf. See Attachment 2. The three distinct support points, “spigots”, for these panels creates stress concentrations around the supports that are best modeled using a finite element model (FEM). A FEM model was created for this panel using Risa-3D software (version 10.0.1), that modeled a 60” wide x 39” tall x 13mm thick tempered and laminated panel, with a 81psf surface load applied. The model generated a 15,979 psi principal axis stress (σ) in the panel. See Attachment 3.

The glass used in the panels was tested to determine its structural capacity, using a static load applied to a test specimen. The specimen was loaded to failure, and the loading was applied to the FEM to determine the equivalent stresses. The failure stress was 35,767 psi. This modeling shows that the panels have calculated factor-of-safety of 2.24. See Attachment 4.

Impact Resistance

For building envelope glazing in wind-borne debris regions, glass that is part of a building envelope must be tested for impact resistance in accordance with American Society for Testing and Materials (ASTM) E1996. This requirement protects a closed building envelope from being penetrated and prevents high wind pressures from filling the building, potentially blowing out windows and lifting the roof off the building. Because these panels are not part of the building enclosure, damage from wind-borne debris would not penetrate the enclosure and its structural elements. Therefore, this test is not required for the panels used as a guardrail system.

Summary

In summary, based on our understanding of the FBC requirements, our conclusions are as follows:

1. Each panel is constructed of fully tempered, laminated glass.
2. Each panel is secured to the structure with three supports.
3. A top rail is not required for these panels.
4. Wind pressure – previous testing confirms that the panels meet the 180 mph factored wind speed requirement, with a calculated factor-of-safety of 2.24.
5. The panels do not require wind debris projectile testing.

Mr. John Ruprecht – Clear View Glass Railings
AET Project No. 05-20608
February 1, 2021
Page 3 of 3

Please call or e-mail us to discuss this analysis or any portion of the project to evaluate your panels.

Sincerely,
American Engineering Testing, Inc.



Chris Hartnett, PE*
Principal Engineer
*MN, WI, AL, MD, MO, NC, ND, OH, PA, TN VA
Phone: 651-647-2750
chartnett@amengtest.com

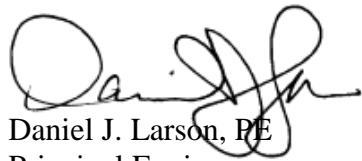

Daniel J. Larson, PE
Principal Engineer
Florida License #70286
Phone: 651-659-1337
dlarson@amengtest.com

Attachment 1: Florida Building Code Figure 1609.1 – Ultimate Wind Design Speed.
Attachment 2: ASCE 7-10 Wind & Pressure Calculations.
Attachment 3. Finite Element Modelling.
Attachment 4: Physical Testing

1609.3 Ultimate Design Wind Speed

The ultimate design wind speed, V_{ult} , in mph, for the determination of the wind loads shall be determined by Figures 1609.3(1), 1609.3(2) and 1609.3(3). The ultimate design wind speed, V_{ult} , for use in the design of Risk Category II buildings and structures shall be obtained from Figure 1609.3(1). The ultimate design wind speed, V_{ult} , for use in the design of Risk Category III and IV buildings and structures shall be obtained from Figure 1609.3(2). The ultimate design wind speed, V_{ult} , for use in the design of Risk Category I buildings and structures shall be obtained from Figure 1609.3(3). The ultimate design wind speed, V_{ult} , for the special wind regions indicated near mountainous terrain and near gorges shall be in accordance with local jurisdiction requirements. The ultimate design wind speeds, V_{ult} , determined by the local jurisdiction shall be in accordance with Section 26.5.1 of ASCE 7. The exact location of wind speed lines shall be established by local ordinance using recognized physical landmarks such as major roads, canals, rivers and lake shores wherever possible.

In nonhurricane-prone regions, when the ultimate design wind speed, V_{ult} , is estimated from regional climatic data, the ultimate design wind speed, V_{ult} , shall be determined in accordance with Section 26.5.3 of ASCE 7.

Attachment 1

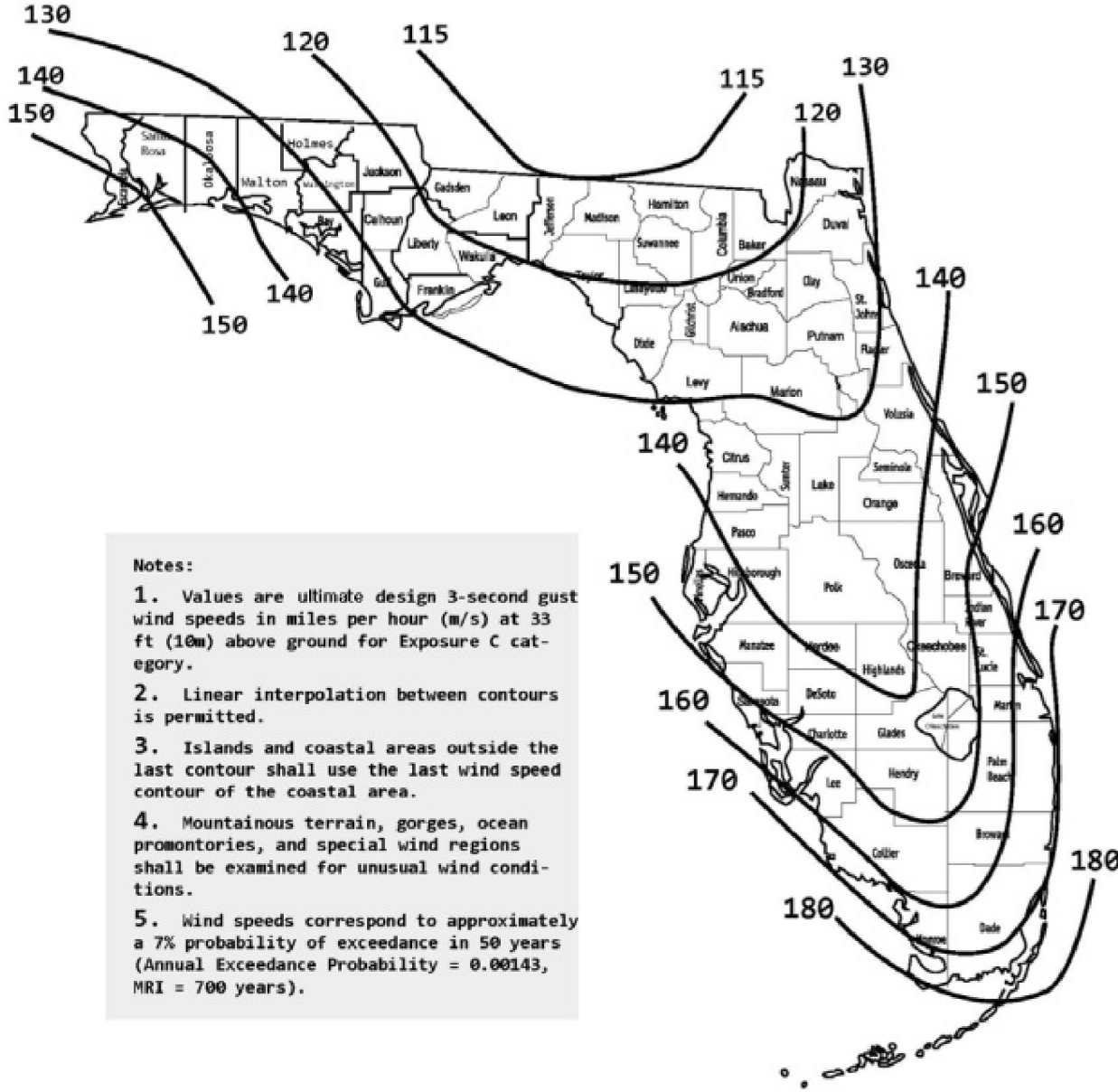

FIGURE 1609.3(1)

ULTIMATE DESIGN WIND SPEEDS, V_{ULT} , FOR RISK CATEGORY II BUILDINGS AND OTHER STRUCTURES

Attachment 1

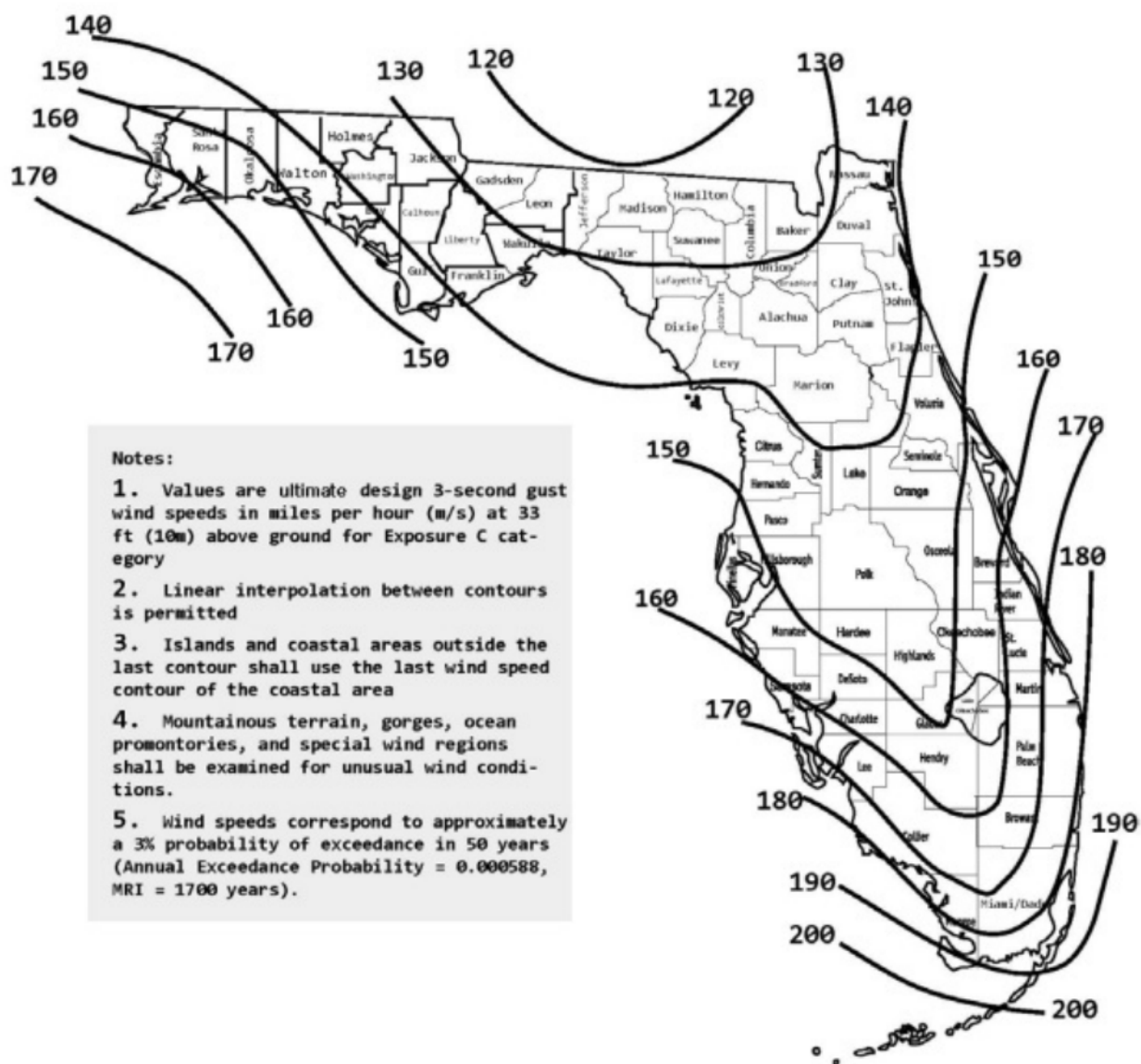

FIGURE 1609.3(2)

ULTIMATE DESIGN WIND SPEEDS, V_{ULT} , FOR RISK CATEGORY III AND IV BUILDINGS AND OTHER STRUCTURES

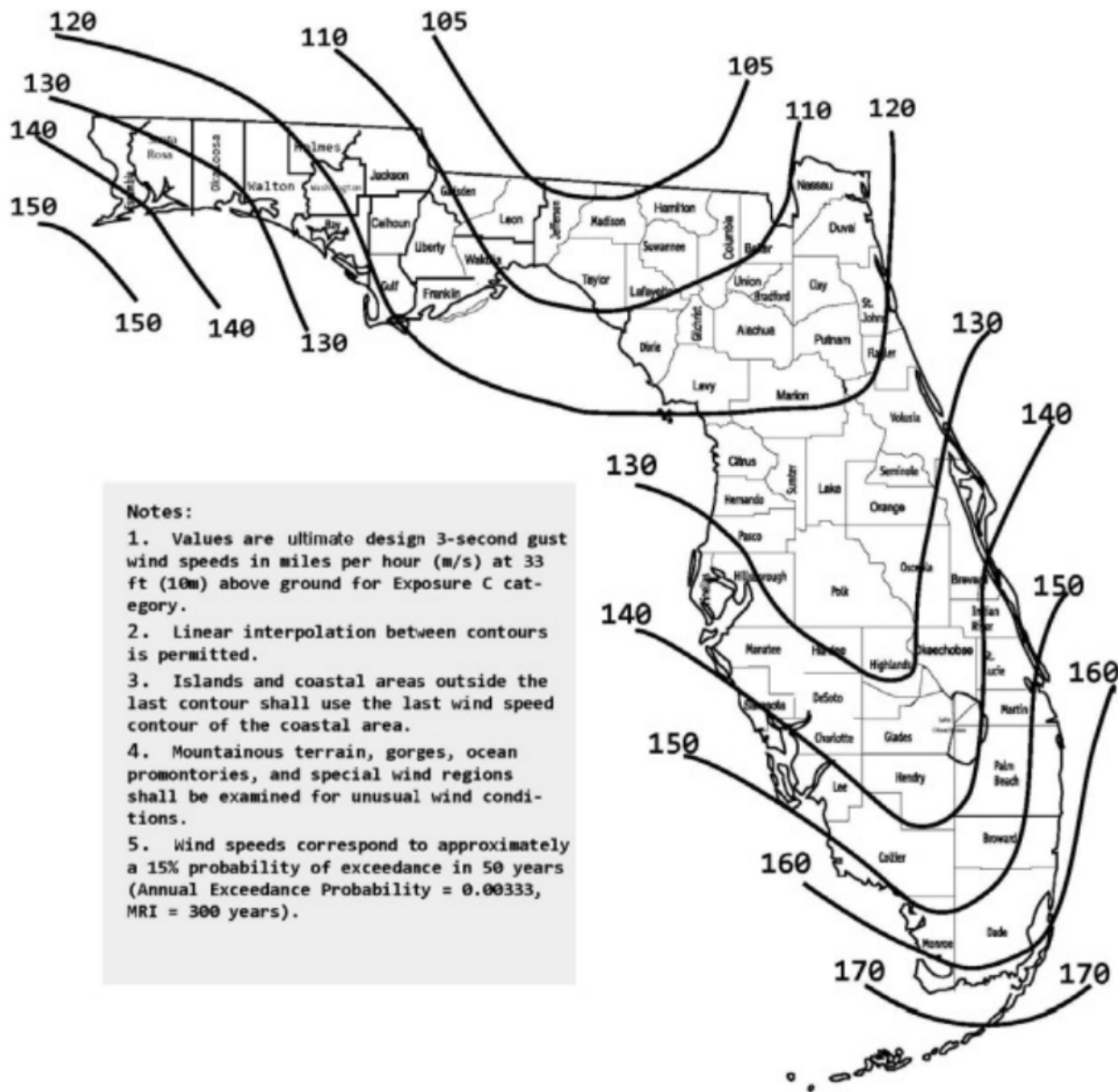

FIGURE 1609.3(3)

ULTIMATE DESIGN WIND SPEEDS, V_{ULT} , FOR RISK CATEGORY I BUILDINGS AND OTHER STRUCTURES

1609.3.1 Wind Speed Conversion

When required, the ultimate design wind speeds of Figures 1609.3(1), 1609.3(2) and 1609.3(3) shall be converted to nominal design wind speeds, V_{asd} , using Table 1609.3.1 or Equation 16-33.

$$V_{asd} = V_{ult} \sqrt{0.6}$$

where:

(Equation 16-33)

V_{asd} = Nominal design wind speed applicable to methods specified in Exceptions 4 and 5 of Section 1609.1.1.

V_{ult} = Ultimate design wind speeds determined from Figures 1609.3(1), 1609.3(2) or 1609.3(3).

TABLE 1609.3.1

V_{ult}	100	110	120	130	140	150	160	170	180	190	200
V_{asd}	78	85	93	101	108	116	124	132	139	147	155

For SI: 1 mile per hour = 0.44 m/s.

- Linear interpolation is permitted.
- V_{asd} = nominal design wind speed applicable to methods specified in Exceptions 1 through 5 of Section 1609.1.1.
- V_{ult} = ultimate design wind speeds determined from Figure 1609.3(1), 1609.3(2) or 1609.3(3).

Attachment 1

Attachment 2

IBC Wind Load Calculations

Project: CVG Railings - Florida High Wind Region
 Project #: 05-20608
 11/5/2020
 Code: Florida Building Code
 Source Document: ASCE 7-10, Chapter 29

Other Structures (Section 6.5.13)

Coefficients		
<u>Coefficient</u>	<u>value</u>	<u>source</u>
Risk Category	ii	Table 1.5-1
V (mph):	139	Figures 26.5-1A-C. All of US e:
Exposure:	c	para 26.7
direction factor, Kd:	0.85	Table 26.6-1
topography fact , Kzt	1	para 26.8
gust factor, G	0.85	Section 26.9
Larger dimension of sign, M (ft)	5	Table 6-11
Smaller dimension of sign, N (ft)	3	Table 6-11
Net force coefficients, Cf	1.8	Figure 29.4-1 through 29.5-3
Average height above ground, (ft)	100	
velocity pres. Expose coeff, Kz		Table 29.3-1
Building height (ft):		
0-15	0.85	
20	0.9	
25	0.94	
30	0.98	
40	1.04	
50	1.09	
60	1.13	
70	1.17	
80	1.21	
90	1.24	
100	1.26	Kh (K @ mean roof ht
velocity pres. Expose coeff, Kh	1.26	Choose highest value of Kz
Velocity pressure, qz	52.97	$qz = .00256 * Kz * Kzt * Kd * V^2$
Projected area normal to wind, Af (sq ft)	15	$= M * N$
Total Force on Supports, F (kips)	1.22	$F = qz * G * Cf * Af$
Equivalent pressure, P (psf)	81.0	$P = F / (M * N)$

Attachment 3: Finite Element Modelling

A finite-element-model (FEM) was created to model the Hercules Glass Panel. The model measures 60" x 39" x 13mm (0.51") thick, and includes 960 elements sized approximately 1.5" square x 13mm (0.51") thick. The model is supported at three points, at the panel "spigots. The spigots are approximately 4" tall x 3" wide. See Figure 1 below.

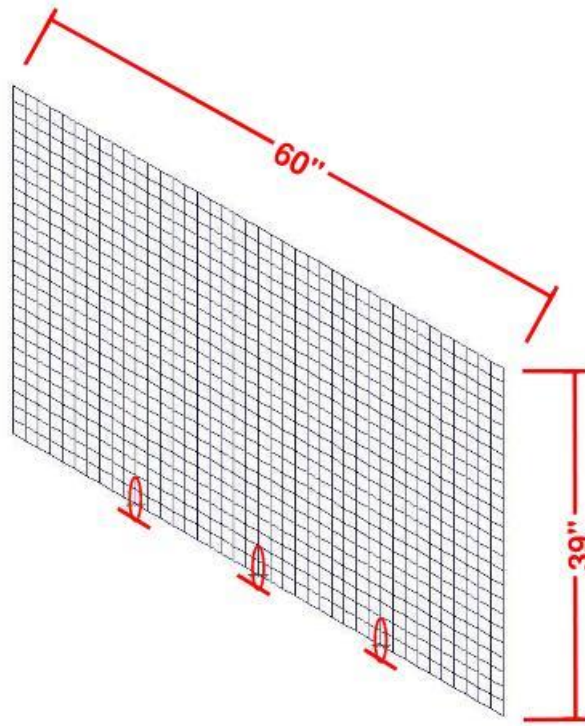

Figure 1: Panel Configuration

The highest stresses caused by a lateral wind load are experienced at the elements around the spigots. Figure 2 shows the element numbers of the panel and a close-up of the elements around the spigots. Note that the elements supported directly by the spigots are blanked out because they are supported by the spigots and are not stressed.

<u>Left spigot</u>	<u>Middle spigot</u>	<u>Right spigot</u>
Element 899	919	939
897	917	937
819	839	859
820	840	860
823	842	863
824	844	864
902	922	942
904	924	944

Attachment 3: Finite Element Modelling

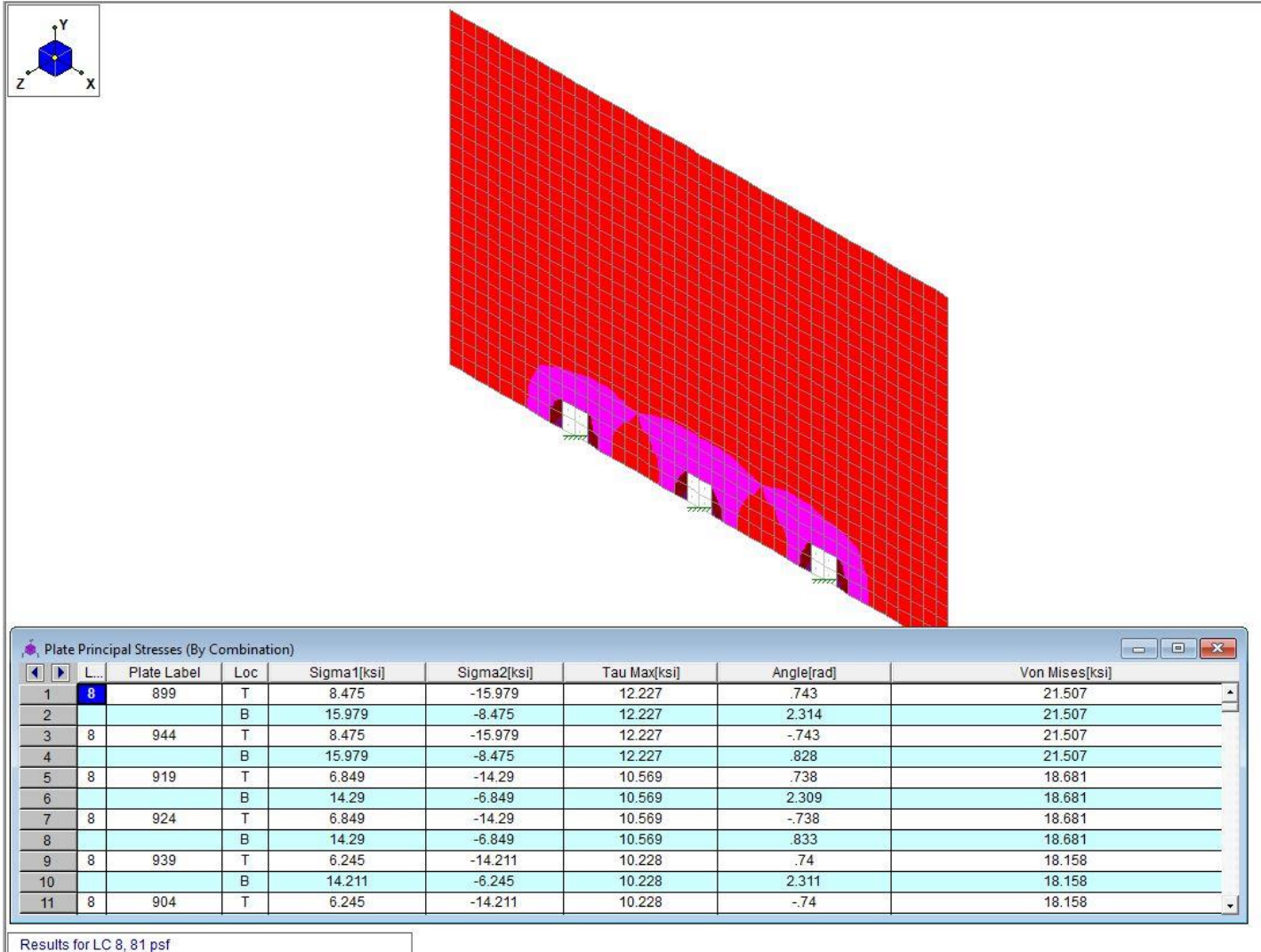
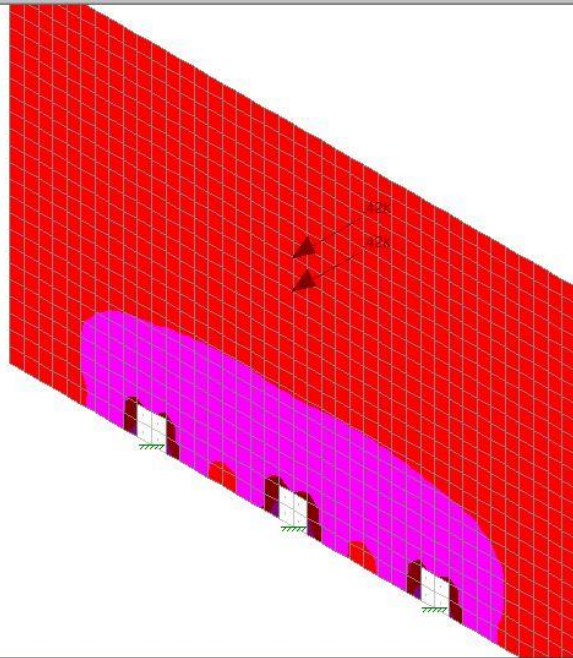

Figure 3: Stresses due to 81 psf (180 mph factored winds)

Attachment 3: Finite Element Modelling



	L...	Plate Label	Loc	Sigma1[ksi]	Sigma2[ksi]	Tau Max[ksi]	Angle[rad]	Von Mises[ksi]
1	5	943	T	8.444	-35.767	22.106	-.277	40.653
2			B	35.767	-8.444	22.106	1.293	40.653
3	5	900	T	8.444	-35.767	22.106	.277	40.653
4			B	35.767	-8.444	22.106	1.848	40.653
5	5	899	T	8.435	-12.214	10.324	.676	17.982
6			B	12.214	-8.435	10.324	2.247	17.982
7	5	944	T	8.435	-12.214	10.324	-.676	17.982
8			B	12.214	-8.435	10.324	.895	17.982
9	5	939	T	6.371	-11.874	9.122	.724	16.038
10			B	11.874	-6.371	9.122	2.295	16.038
11	5	904	T	6.371	-11.874	9.122	-.724	16.038

Loads: BLC 5, 820#@28"
Results for LC 5, 820@28"

Figure 4: Stresses due to failure load (820 psf @ 28")

Attachment 4: Physical Testing

July 13, 2020

Building Code Requirements

The International Building Code (IBC) and International Residential Code (IRC) are “model codes” created by the International Code Council, intended to be used by states and municipalities as they publish their own building codes. Section 1607.8 of the IBC requires that “handrails and guards shall be designed to resist a linear load of 50 plf.” It also requires the system to resist a 200# concentrated load that produces the “maximum load effect” on any element within the system. The 2018 IRC Table R201.5 extends this requirement into residential construction. It is understood within the building design industry that loads applied to the top of the panel create the maximum load effect; structural design assumes this loading condition.

Section 1607.8 of the IBC also refers to IBC section 2407 that adds a requirement for all-glass handrails and guards to “be laminated glass constructed of fully tempered or heat-strengthened glass”; this requirement was added in the 2015 IBC code cycle. Section 2407.1.1 adds the significant requirement: “a design factor of four shall be used for safety”. This addition bumps up the linear load to 200 plf and the concentrated load to 800#. Presumably, this is intended to prevent the glass from shattering and injuring people below.

Exterior glass guardrail panels are designed to resist two load types: wind loads, and “live” loads such as a person or object pushing on or striking the panel from the side or from above. Wind loading on a panel can vary greatly based on location, terrain (wooded vs open) and elevation above ground; these are governed by publication ASCE 7 (American Society of Civil Engineers Minimum Design Loads for Buildings and Other Structures). Wind speeds of 115 psf are used to calculate wind pressures against the glass, which generally vary from 17 psf (2nd story in wooded area) to 35 psf (30 stories tall in open terrain). The wind speeds required to match the stresses created by the 800# point load are 192 mph for the 42” tall panel and 215 mph for the 36” tall panel; these are only seen in a Category 5 hurricane or a tornado. Therefore, the 800# horizontal point load is the worst-case scenario for the panels. Note: panel design in “high wind” regions such as the coastal Southeast US are designed to resist flying debris and are subject to different loading requirements. Calculation methods to arrive at these values include computer modeling using finite element analysis; criteria specific to Clear View’s panels and support configuration were used.

Hercules Glass Testing

Testing was performed on the Hercules Glass panel by Clear View’s glass supplier, to simulate the forces created by 800# horizontal and vertical point loads on the panel (loads are not required to be simultaneous). The vertical load test is straightforward and is shown in photo 1. Note: the intent was to load the panel to failure; however, the testers ran out of sandbags at 2,520 pounds, without failure. Given the difficulty of pushing an 800# load horizontally against the panel, a test rig was set up that supports the panel on its side and places sandbags vertically on the panel. The panel is supported 28” from the top of panel (creating a 28” cantilever), with a heavy counterweight holding down the bottom of the panel mounted in its spigots. Sandbags were placed at the top edge of the panel until failure. See Diagram 1 and photo 2. The panel failed after one minute with 820 pounds loaded on its edge, which is equivalent to 547 pounds for a 42” tall panel. Due to the laminate construction of the panels (similar to a vehicle windshield), the panel broke into small pieces that were retained within the panel, preventing

Attachment 4: Physical Testing

dangerous flying glass debris. See photo 3. This test shows that the panel meets the intent to create a strong and safe barrier that can withstand reasonable loading (factor of safety of 2.5), and does not explode with dangerous glass shards during excessive loading.



Photo 1: Panel loaded vertically with 2,520 pounds.



Photo 2: Loading of panel with sandbags, simulating horizontal force

Attachment 4: Physical Testing

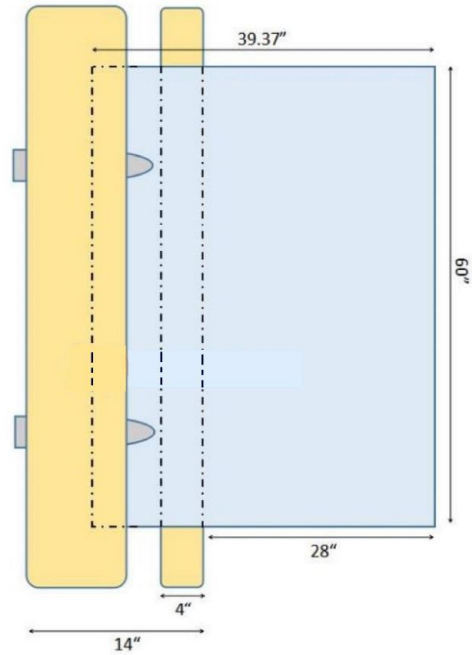

Diagram 1: Test rig lying on its side, looking from above, showing panel supported at 28" and at bottom of panel

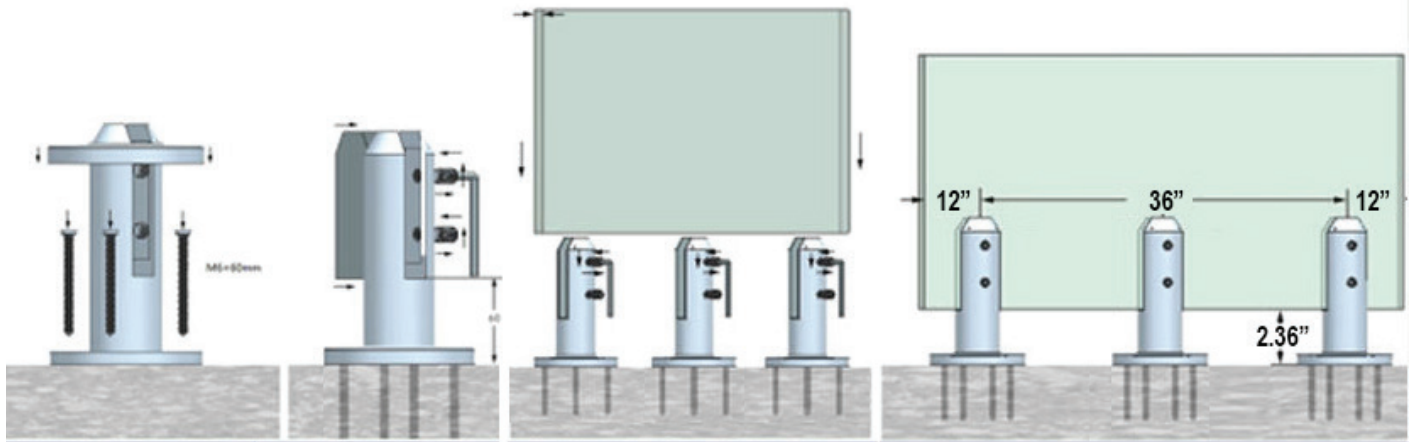

Photo 3: Panel after failure, showing all glass intact within laminate structure.



ClearView
GLASS RAILINGS

INSTALLATION WITH THREE SPIGOTS



Part Number	CVGR 316 SSOD48-180 Satin Finish
Product Name	Round Deck Mount Spigot
Spigot Size	1.9" diameter x 7.1" tall
Spigot Weight	5.5 lbs.
Glass Thickness/ Dimensions/Weight (per panel)	13mm/ 60" width x 39.37" height/98.5 lbs.
Accessories Included	Base Cover, Rubber Gasket

Wood Deck Installation

The hold down force for each spigot is 2,500 lbs. We suggest using 3/8" diameter x 3.5" A354 structural bolts as they have sufficient capacity to resist this force. Use with flat washer to fasten spigots to wood deck. A354 structural bolts and washer should be cadmium plated or stainless steel so they do not rust.

Lag bolts must be installed into rim joists or lam beam or properly blocked sub structure. If lag bolts are attached to deck planks only failure will occur as a result of improper installation. Improper installation and failure may result in injuries or death. Do it once and do it right!

Helpful Installation Tips

- Apply a bit of talcum powder to the inside of the spigot rubber boot to help the glass slide in the rubber boot, not grab the rubber boot.
- Mark spigot location on glass panels with a crayon or wax marker. This allows for fast and easier installation of panel in proper location.
- Some clients have suggested screwing the rim joist to the joist as the screws will hold the rim joist tight to the joist where as nails may not.



ClearView
GLASS RAILINGS

SPIGOT SPECS

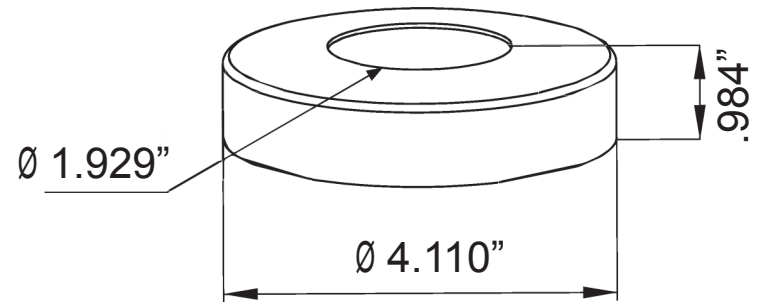
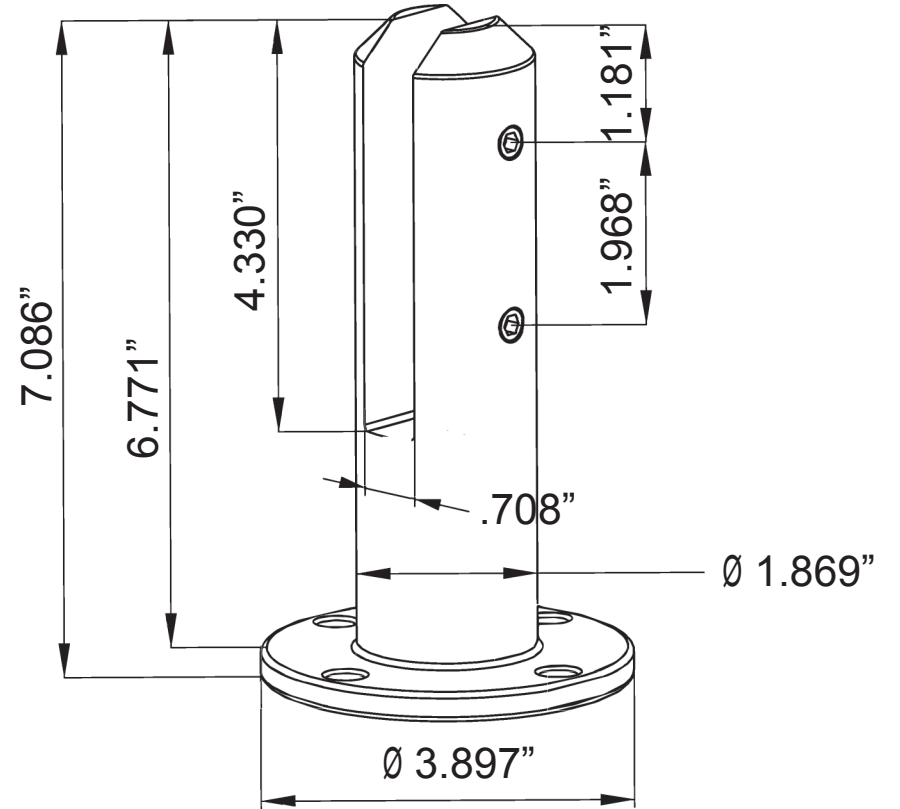
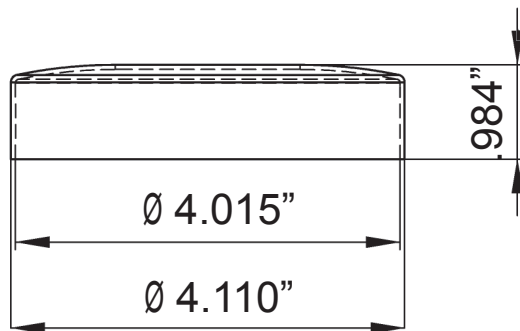
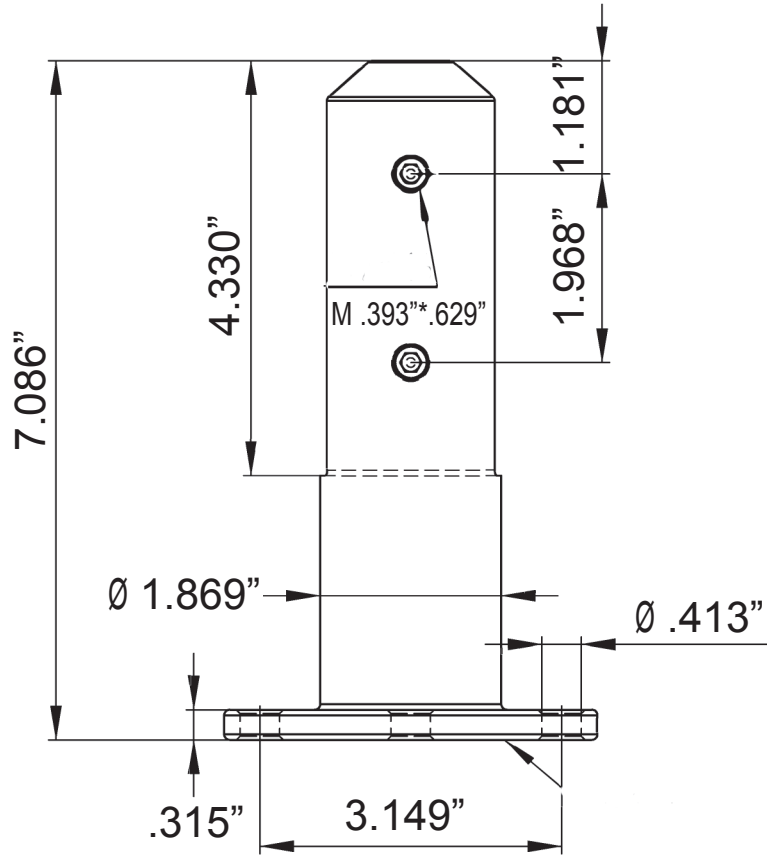



safety glazing
certification council

Administrative Office, AMS, Inc.
205 West Main Street, PO Box 730
Sackets Harbor, NY 13685
Phone: (315) 646-2234
E-mail: SGCC@amscert.com



#0961
ISO/IEC 17065
Product Certification Body

ACKNOWLEDGEMENT OF CERTIFICATION

THIS IS TO ACKNOWLEDGE THAT AS OF THIS DATE

QL Glass Technology Co., Ltd
Manufacturers of Hercules Glass by ClearView Glass Railings

IS A CURRENT LICENSEE AND HAS MET ALL GUIDELINES AND REQUIREMENTS FOR THE SGCC® CERTIFICATION PROGRAM AND AS SUCH IS ELIGIBLE TO LABEL THE BELOW INDICATED PRODUCT(S) AS SGCC® CERTIFIED. REPRESENTATIVE SAMPLES OF THE BELOW PRODUCTS HAVE BEEN FOUND TO BE IN COMPLIANCE WITH ANSI Z97.1-2015 AS INDICATED AND CPSC 16 CFR 1201 STANDARDS, KNOWN AS COMPOSITE CERTIFICATION (COMP), OR BOTH STANDARDS WITH CAN/CGSB 12.1-2017 KNOWN AS COMP+CAN.

<u>SGCC#</u>	<u>IN</u>	<u>MM</u>	<u>Attributes</u>	<u>INT</u>	<u>Type Code</u>	<u>Max Size</u>	<u>ANSI Class</u>	<u>Test Std</u>
7110	5/32	4			TTG	U	A	COMP+CAN
7125	1/8	3			TTG	U	A	COMP+CAN
7126	3/8	10			TTG	U	A	COMP+CAN
8019	5/16	8			TTG	U	A	COMP+CAN
8020	1/2	12			TTG	U	A	COMP+CAN
8021	(S)	6	(b)(A)	(.030)	LTG	U	A	COMP+CAN
8063	1/4	6			TTG	U	A	COMP+CAN

THIS SGCC® PROGRAM CERTIFICATION IS CURRENT AND IN FULL EFFECT AS OF THIS ISSUE DATE. CERTIFICATION IN THE SGCC® PROGRAM IS SUBJECT TO SEMI-ANNUAL RENEWAL. PLEASE CHECK THE SGCC WEBSITE AT WWW.SGCC.ORG OR THIS OFFICE FOR MOST CURRENT INFORMATION.

Monday, July 25, 2022
DATE OF ISSUE

L22
CERTIFICATION PERIOD

ADMINISTRATIVE MANAGER



safety glazing certification council
P.O. BOX 730
SACKETS HARBOR, N. Y. 13685 PHONE
315-646-2234
FAX 315-646-2297

Guidance for the SGCC Quality Assurance Production Testing

(1/26/2022)

Summary

SGCC® requires licensees to have a working quality assurance program for the fabrication of safety glazing. Compliance to quality assurance requirements is validated at the first plant inspection after products are certified. Adherence is verified during twice per year plant visits. These requirements were adopted to improve the overall quality and reliability of safety glazing products in the program. These requirements are in addition to the ANSI, CPSC and CAN/CGSB 12.1 compliance testing required by the SGCC® certification program. The intent is to enhance the quality of products produced in the interim production periods between test cycles. Although a quality assurance program is a fundamental element of good fabrication practices, only successful testing to ANSI Z97.1, 16 CFR 1201 or CAN/CGSB 12.1 is valid proof of compliance with these standards.

As of **January 1, 2020**, a licensee's quality assurance program, as a minimum, must have the following elements (see page 18 of the *January Certified Products Directory* for the full detailed list):

- A Quality System Manual
- Designated Representative for Quality Assurance
- Process Control(s)
- Production testing
- Calibration

This Guidance document is to help further define and provide additional information on SGCCs “Production Testing” requirements. *Note: Where ANSI or ASTM test methods are referenced below, other like national or internationally accepted test methods (for example EN 12600) are acceptable.*

Production testing – Procedures shall describe testing of regular production and shall include SGCC requirements for safety glazing products. The SGCC auditor shall 1) review historical testing records ensuring procedures were followed if failure occurred 2) witness at least one production test and 3) review the method of evaluation during twice per year visits. When samples are not available, the manufacturer shall describe to the auditor how production testing is performed. Where ANSI or ASTM test methods are referenced below, other like national or internationally accepted test methods (for example EN 12600) are acceptable. Records of testing shall be maintained for a minimum of 10 years.

Tempered – ANSI Z97.1 Center Punch and/or Impactor Test - As a minimum, testing shall occur on the first of each product thickness per shift. Additional testing may be appropriate.

Laminated – ASTM F3007 and/or ANSI Z97.1 Impactor Test - During regular production periods, a minimum sample collection shall be performed weekly, and actual testing occur at least monthly. Sample collection must be traceable to specific production runs. For ASTM F3007 testing, sampling and testing shall occur as a minimum on the thinnest product(s) produced. Evaluation shall occur and drop height selection as a minimum shall be in accordance with ASTM F3006.

Production Testing – Tempered (Center Punch):

Reference Documents: *ANSI Z97.1 – 2015* For safety glazing materials used in buildings

Equipment: Sharp impactor¹, Specimen support frame (flat base with adjustable horizontal curbs), calibrated scale, calibrated micrometer

Additional Notes:

- ANSI Z97.1 paragraph 5.2.2 (1) references “ ... place curb lightly along the specimen edges ...”. It is recognized that it may not be practical to accomplish this for all shapes and sizes of production test samples. Generally testing with the absence of curbing is viewed as a “worst case” test, compared to the use of curbing.
- Because of the elevated temperature of tempered glass during the production process you may disregard the section of ANSI Z97.1 section 5.2 which speaks to the conditioning of the specimen prior to testing.

Steps for conducting ANSI Center Punch Test (ANSI Z97.1-2015 Section 5.2)

**Note: Review ANSI Z97.1-2015 specifications for details, the intent of this document is to be used as a Guidance tool*

- Specimen size - is at the discretion of the fabricator, **record**
- Specimen thickness / weight - specimen must be measured and/or weighed to determine ten square inches of the original specimen determined from the weight, width, length of that specimen, **record**
- Specimen must be from your production process, **record** date and time of specimen production
- Frequency as a minimum, testing shall occur on the first of each product thickness per shift (additional testing may be appropriate).
- Setup testing – Flat glass: place the specimen on the flat base and place the curb lightly along the specimen edges so the sample can elongate slightly.
- Test the Specimen – strike the test specimen 1in. (25 mm) inboard of the longest edge at its midpoint until fracture occurs. (Figure 8 below can be found in the ANSI Z97.1-2015 Section 5.2.4)

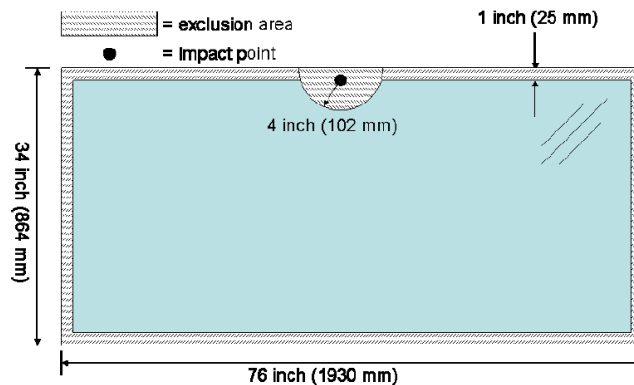

Figure 8: Center Punch Fragmentation

- Interpretation of Results. Following impact/fracturing, within 5 minutes collect and weigh the ten (10) largest crack-free particles. The total weight of the ten (10) largest crack free pieces shall weigh no more than the equivalent weight of 10 square inches of the original test sample. NOTE no one particle shall be longer than 4” (see ANSI Z97.1-2015 Section 5.2.4(2)). **Record** results. See *example Break Test Record Data Sheet*.

¹ Recommended spring loaded center punch Model: Starrett 818 Automatic Center Punch with Adjustable Stroke, 5” length, 5/8” diameter or Model: Starrett 18C Automatic Center Punch Heavy-Duty with Adjustable Stroke, 5 ¼” length, 11/16” diameter

Production Testing – Laminated (Ball Drop Impact):

Reference Documents: *ASTM F3007-19 Standard Test Method for Ball Drop Impact Resistance of Laminated Architectural Flat Glass & ASTM F3006-19 Standard Specification for Ball Drop Impact Resistance of Laminated Architectural Flat Glazing. Please note testing to the ASTM F3006 - 20 standard shall be considered equivalent to testing to the 2019 edition.*

Hazards: Warning It is the responsibility of the user of the standards listed above and discussed here on out to establish appropriate health and safety practices, and to determine the applicability of regulatory limitations prior to use.

Equipment: 2.3kg (+/- 0.1kg) 83mm diameter smooth solid steel ball, support frame (see Figure 1 ASTM F3007-19), mechanism for ensuring the unimpeded drop of the ball, calibrated micrometer. (See ASTM F3007-19 Section 6 for more details) (see attached Material list for more details)

Drop Height: Measurement shall be taken from the bottom of the ball to the surface of the glass.

CLASS A	3.66 m (+1.27 cm)	12 ft (+ ½ in)
CLASS B	0.75 m (+1.27 cm)	2.46 ft (+ ½ in)

Clamping: Only clamp a sample to prevent pull-through or sample displacement from impact frame, which will result in a non-test. Over clamping a sample may result in more a severe test which does not correlate to ANSI Z97.1 2015.

Sample Selection: Testing shall occur on the thinnest of each product produced for certification (based on SGCC #). Select at least 3 samples (with 4 being the maximum number of samples allowed for selection).

Spall Measurement: Spall measurement is not required as part of the QA in plant testing procedure. In the standard F3007 – 19 sections 9.3 and 9.7 may be disregarded. In the standard F3006 – 19 sections 7.4.3 and 8.1.7 – 8.1.10 may be disregarded.

Steps to setup and conduct the Ball Drop Impact test:

**Note - Frequency as a minimum collection shall be performed weekly and actual testing occur at least monthly*

Step 1 SAMPLE SELECTION: Specimen must be from your production process. Specimen size, 305 +/- 10mm by 305 +/- 10mm (12 +/- 0.4” x 12 +/- 0.4”). **Record** specimen glass configuration, date and time of specimen production.

Step 2 CONDITIONING: Condition the specimen for approximately 4hrs. at 24 +/- 5°C (between 66 - 84°F). **Record** the glass surface temperature.

Step 3 INITIAL MEASUREMENTS: Measure and **record** the **thinnest** thickness. *The thickness of the specimen shall be measured at the midpoint of the four sides within 1in. of the edge.*

Step 4 SETUP TESTING: Place specimen on the support frame (does not require clamping but recommended so as not to result in a “deemed non-test” if the specimen falls off the frame when impacted See ASTM F3007-13 Table 1 Note 1).

Step 5 DROP HEIGHT AND RELEASE: Using Table 2 ASTM F3006-19 to determine the drop height (note the 1st listed height 0.75m correlates with ANSI Z97.1 Class **B**). Release the steel ball from an at-rest position and impact the specimen within 25mm (1in.) of the center of the glass. If using a pull pin release system ensure to remove the pin with 1 rapid motion *Note: Recommend testing to what you are currently SGCC certified to (if you are certified to ANSI Z97.1-2015 Class A test drop height of 3.66m or to ANSI Z97.1-2015 Class B test drop height of 0.75m)*

Step 6 INTERPRETATION OF RESULTS: Following impact, within a 5 sec interval determine the penetration resistance/retention characteristics of the specimen using ASTM F3007-19 Table 1. **Record** results.

Step 7 CONTINUED TESTING: Repeat this test on at least 2 (maximum of 3) additional specimens from the same production lot at the same or elevated drop height. **Record** results.

Step 8 REPORT RESULTS: Report **results**. See report requirements found in ASTM F3007-19 Section 11.

Suitable Alternatives for Production Testing

Production Testing:

Mandatory in-plant testing

Required by SGCC QA and Testing requirements to address consistency of production

Quality Assurance Testing:

Non-Mandatory in-plant testing

Recommended by suppliers and/or internal policies

(While SGCC does not require or endorse many forms of in-plant quality assurance testing, SGCC recognizes the value of such tests and supports testing beyond SGCC mandatory testing as a viable option for QA.)

NOTE: We are not suggesting these standards are equivalent for production control

Standard / Equipment	Title	Production Test	Suitable Alternate For	Requirements When Testing to This Standard
ANSI Z26.1	Standard for Safety Glazing Materials for Glazing Motor Vehicles	Penetration Resistance Test 20 (Section 7.20)	ASTM F3006 & 3007 Ball Drop Test laminated glass	<ul style="list-style-type: none"> - Use 3 Test Samples Only (Max 4) - Ball Drop height should reflect SGCC QA Guidance Document
EN 12600	Glass in Building Impact Test Method and classification of flat glass	Pendulum test	ANSI Z97.1 Impact Test Laminated or tempered glass	<ul style="list-style-type: none"> - Test up to 3 drop heights (Class 1,2,3) - Only for testing 34 x 76" - Penetration force is 25 N instead of 18 N - No Center Punch test on tempered sample if breakage doesn't occur - No particle weight determination
EN 14449	Glass in Building - Laminated glass and laminated safety glass	Ball Drop Test Annex C.2	ASTM F3006 & 3007 Ball Drop Test laminated glass	<ul style="list-style-type: none"> - Drop Height not Defined - Ball different dimensions - Samples Tested different dimensions
		Pendulum Impact Test Annex C.3	ANSI Z97.1 Impact Test laminated glass	<ul style="list-style-type: none"> - Specification for penetration resistance only
GANALD-100	Standard Test Method for Ball Drop Impact of Laminated Architectural Flat Glass	Ball Drop Test	ASTM 3007 Ball Drop Test laminated glass	<ul style="list-style-type: none"> - This is only the testing procedure, the specification should still refer to ASTM F3006

Laminated

Tempered

Standard / Equipment	Title	Production Test	Suitable Alternate For	Requirements When Testing to This Standard
Optical Scanner	See Manufactures Specifications	See Manufactures Specifications	Evaluation of ANSI Z97.1 Center Punch Fragmentation Test tempered glass	<ul style="list-style-type: none"> - Follow ANSI Z97.1 - 15 (R2020) section 5.2 Fragmentation Procedure (or suitable alternative) - Scanner to be used in place of sections 5.2.3 & 5.2.4
EN 12600	Glass in Building Impact Test Method and classification of flat glass	Pendulum test	ANSI Z97.1 Impact Test Laminated or tempered glass	<ul style="list-style-type: none"> - Test up to 3 drop heights (Class 1,2,3) - Only for testing 34 x 76" - Penetration force is 25 N instead of 18 N - No Center Punch test on tempered sample if breakage doesn't occur - No particle weight determination
EN 12150	Glass in Building - Thermally Toughened Soda Lime Silicate Safety Glass	Fragmentation Test (Section 8)	ANSI Z97.1 Center Punch Fragmentation Test tempered glass	<ul style="list-style-type: none"> - Test for Thermally Toughened Soda Lime Silicate Safety Glass - Size of specimen tested may be at discretion of participant - Particle evaluation is number of particles in 50mmx 50mm mask
EN 14179	Glass in building - Heat soaked thermally toughened soda lime silicate safety glass	Fragmentation Test (Section 10)	ANSI Z97.1 Center Punch Fragmentation Test tempered glass	<ul style="list-style-type: none"> - Test for Heat soaked thermally toughened soda lime silicate safety glass - Strike specimen 1" in from edge
GANA TD-101	Standard Test Method for Center Punch Frag. of Fully Tempered Flat Glass	Fragmentation Test	ANSI Z97.1 Center Punch Fragmentation Test tempered glass	<ul style="list-style-type: none"> - Curbing is not optional as stated in this standard - Adhesive tape is written to be equivalent of curbing in this standard
NOM-146-SCFI-2016	Glass products-safety glass used in construction-specifications and test methods	Section 7.3	ANSI Z97.1 Center Punch Fragmentation Test tempered glass	<ul style="list-style-type: none"> -Testing can be done on a single sample, size at discretion of participant -Strike should be 1" from glass edge, with 8" D exclusion area, and 1" perimeter exclusion area -10 largest particles or written evaluation method
		Section 7.5	ANSI Z97.1 Impact Test Laminated or tempered glass	<ul style="list-style-type: none"> -Level 1 (Type B) & Level 2 (Type A) -4lb force should be applied when evaluating tears -Particle Evaluation to be done as per ANSI Z97.1