

OPERATOR'S MANUAL AND PARTS LIST MODEL GRTCS250Z 0° COIL SIDING NAILER



Distributed by/Distribuido por:

PRIMESOURCE™
BUILDING PRODUCTS, INC.

Inving, Texas 75038 USA
www.primesourcebp.com
Made in Taiwan
Hecho en Taiwn

Imported by/Importé par:

PRIMESOURCE™
BUILDING PRODUCTS CANADA CORPORATION

Inving, Texas 75038 USA
www.primesourcebp.com
Made in Taiwan
Fabriqué a Taiwan

TABLE OF CONTENTS

TABLE OF CONTENTS ----- 2

SPECIFICATIONS ----- 3

SAFETY ----- 4

TOOL PARTS ----- 8

PART DESCRIPTIONS ----- 9

OPERATION ----- 10

 Loading Fasteners ----- 10

 Adjusting Nail Drive ----- 11

 Clearing Nail Jams ----- 11

 Tool Operation ----- 12

MAINTENANCE ----- 13

 Lubrication ----- 13

 Cleaning ----- 13

 Trigger Check ----- 13

PARTS SCHEMATIC ----- 14

PARTS LIST ----- 15

TROUBLESHOOTING ----- 16

TOOL CHECKS ----- 17

WARRANTY ----- 18

IMPORTANT SAFETY INFORMATION

You must read this entire manual and familiarize yourself with all safety, operating, and service instructions before loading, handling, or using your tool. When used correctly, pneumatic fastening tools provide a lightweight, powerful, and safe means of fastening. Used improperly, these tools can cause serious injury to you and those around you.

SPECIFICATIONS

SPECIFICATIONS

MODEL	GRTCS250Z COIL SIDING NAILER
FASTENER RANGE - PLASTIC	1 1/4" - 2 1/2" (3.18 cm - 6.35 cm)
FASTENER RANGE - DIAMETER	.080 - .109" (2.03 mm to 2.80 mm)
FASTENER TYPE	0° PLASTIC COLLATED COIL NAILS
MAGAZINE CAPACITY	200 - 350 Nails
MAX AIR PRESSURE	120 psi (8.3 bar)
MIN AIR PRESSURE	70 psi (4.8 bar)
TOOL WEIGHT	5.00 lbs. (2.27 kg)
TOOL LENGTH	11.81" (30 cm)
TOOL HEIGHT	12.6" (32 cm)
TOOL WIDTH	5.75" (14.6 cm)
TRIGGER TYPE	Dual Action
AIR INLET	1/4 NPT
AIR CONNECTION	MALE QUICK CONNECT COUPLER
LUBRICATION	10W Air Tool Oil (Provided)

NOISE CHARACTERISTIC VALUES IN ACCORDANCE WITH ISO 3774, ISO 11201:

A-weighted single-event sound pressure level at operator's position -----	LpA, 1s = 90 dBA
A-weighted single-event sound power level -----	LwA, 1s = 101 dBA
A-weighted single-event surface sound pressure level -----	LpA, 1s = 88 dBA

VIBRATION CHARACTERISTIC VALUES IN ACCORDANCE WITH ISO 8862-1

Weighted root mean square acceleration ----- = 3.0 m/s²

For best results, use only Grip-Rite™ collated fasteners.

FASTENER SELECTION CHART

SIZE	BOX QTY.	NAIL SHANK	GALVANIZED	EXTERIOR GALVANIZED	STAINLESS STEEL
1-3/4" X .086	3.6M	Ring		GR166GL	
1-7/8" x .092	9M	Smooth	GR150G		
1-7/8" X .092	9M	Ring	GR151G		
2-1/4" X .099	3.6M	Ring			GR158SL
2-1/4" X .099	7.2M	Smooth	GR153G		
2-1/4" X .099	7.2M	Ring	GR158G		

SAFETY LABELS

This pneumatic fastening tool includes a warning label to help remind you of important safety information when operating the tool. The safety label must be legible at all times, and must be replaced if it becomes worn or damaged.



SAFETY SYMBOLS

These safety symbols provide a visual reminder of basic safety rules, and the personal injury hazard that may arise if all safety and operating instructions are not followed. Make sure you understand the meaning of each of these symbols, and protect yourself and others by obeying all safety and operating instructions.

SYMBOL	DESCRIPTION
	READ THE MANUAL - The manual contains important safety and operating instructions that must be followed. All tool users must read the manual before using the tool.
	WEAR SAFETY GLASSES - Tool operator and bystanders must wear safety glasses with side shield that meet ANSI Z87.1 requirements.
	RISK OF PERSONAL INJURY - Failure to follow all safety and operating instructions, or misuse of the tool, can result in serious injury to tool operator and bystanders.

SAFETY INSTRUCTIONS



WEAR SAFETY GLASSES

Always wear safety glasses with side shields that meet ANSI Z87.1 requirements when operating the tool. Make sure all others in work area wear safety glasses.



WEAR HEARING PROTECTION

Wear hearing protection to protect your hearing from noise. Prolonged exposure to loud noise can result in hearing loss.



NEVER OPERATE THE TOOL WITH OXYGEN OR OTHER BOTTLED GASES

Oxygen and other reactive or high-pressure bottled gases can cause the tool to explode. Use clean, dry regulated compressed air from a properly operating air compressor.

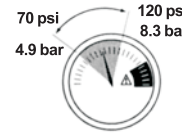

DO NOT EXCEED MAXIMUM RECOMMENDED OPERATING AIR PRESSURE OF 120 PSI / 8.3 Bar.

Exceeding the maximum recommended air pressure can cause the tool housing to burst, or cause premature failure of components.



NEVER CONNECT THE TOOL TO AN AIR SUPPLY THAT HAS THE POTENTIAL TO EXCEED 180 PSI/12.4 Bar.

Using a regulated air supply with a line or tank pressure greater than 180 psi can cause the tool to burst if the air line regulator fails suddenly.

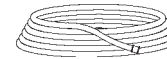

USE AN AIR HOSE RATED FOR 180 PSI/12.4 Bar OR GREATER

Always use air hose rated to handle 180 psi or the maximum potential pressure of the air supply.

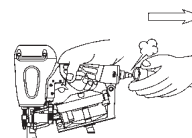

ONLY USE A RELIEVING-TYPE AIR COUPLING IN THE TOOL AIR INLET OPENING

Use of a non-relieving air coupling on the tool can trap air inside the tool housing, and allow the tool to drive a fastener even after the air hose has been disconnected.

SAFETY INSTRUCTIONS

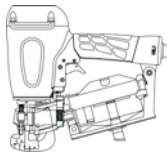

DO NOT ATTEMPT TO OPERATE THE TOOL IF THE TOOL'S OPERATING CONTROLS HAVE BEEN MODIFIED OR ARE NOT WORKING PROPERLY.

Attempting to use a tool with modified or malfunctioning trigger or workpiece contact can result in a fastener being driven unintentionally.

USE CORRECT FASTENERS

Only use the correct fastener for the tool. Using fasteners with incorrect specifications can jam the tool or cause serious injuries.

USE THE CORRECT FASTENERS FOR THE APPLICATION.

Using the wrong fasteners can cause the workpiece to split and allow the fastener to fly free.

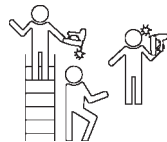

KEEP TOOL POINTED IN A SAFE DIRECTION WHEN LOADING FASTENERS.

Never point the tool at yourself or anyone else when loading fasteners.

DO NOT LOAD TOOL WITH TRIGGER OR WORKPIECE CONTACT DEPRESSED.

Depressing the trigger or workpiece contact during loading can result in an unintentional fastener drive if both devices are accidentally actuated at the same time.

KEEP FINGER OFF TRIGGER UNTIL TOOL IS IN POSITION TO DRIVE A FASTENER.

An unexpected bump or sudden contact with your body or that of a bystander can result in serious injuries.

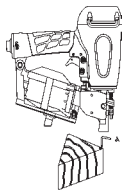

AVOID DRIVING FASTENERS INTO KNOTS, ON TOP OF OTHER FASTENERS, AT WORKPIECE EDGES, OR INTO BRITTLE MATERIALS.

Driving fasteners into extremely hard materials, or driving into workpiece edges, can cause fasteners to deflect away from the workpiece. Flying fasteners can cause serious injuries.

SAFETY INSTRUCTIONS

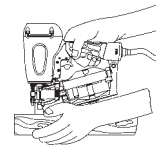

KEEP HANDS AND BODY PARTS AWAY FROM AREA BEING FASTENED.

Fasteners can deflect and turn as they are being driven into the workpiece, and penetrate fingers, hands, and other body parts that may be in the fastening area.



DO NOT OVERREACH OR WORK WHILE ON UNSTABLE FOOTING

If you lose your balance while fastening, you could drive a fastener into yourself or a bystander.

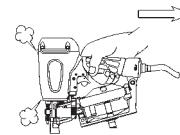

DO NOT USE TOOL IF TOOL MALFUNCTIONS OR BEGINS LEAKING AIR.

Operating a malfunctioning tool can result in an unexpected fastener discharge and injury to yourself or others.

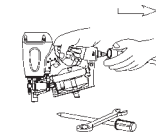

DISCONNECT THE TOOL FROM THE AIR SUPPLY TO RELOAD, CLEAR JAMS, OR PERFORM MAINTENANCE.

Never attempt to reload a tool, clear a jam, or perform maintenance without first disconnecting the air supply.

NEVER LEAVE A LOADED, PRESSURIZED TOOL UNATTENDED

A loaded, pressurized tool could be picked up or handled by someone who is unfamiliar with the tool or that has not read the tool manual.

KEEP TOOLS OUT OF THE REACH OF CHILDREN

Place the tool back in the tool box after use, and store the tool out of reach.

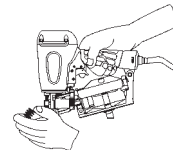

DO NOT MODIFY TOOL

Modifications can cause a tool to be unsafe and can cause the tool to operate improperly.

DESCRIPTION

TOOL PARTS

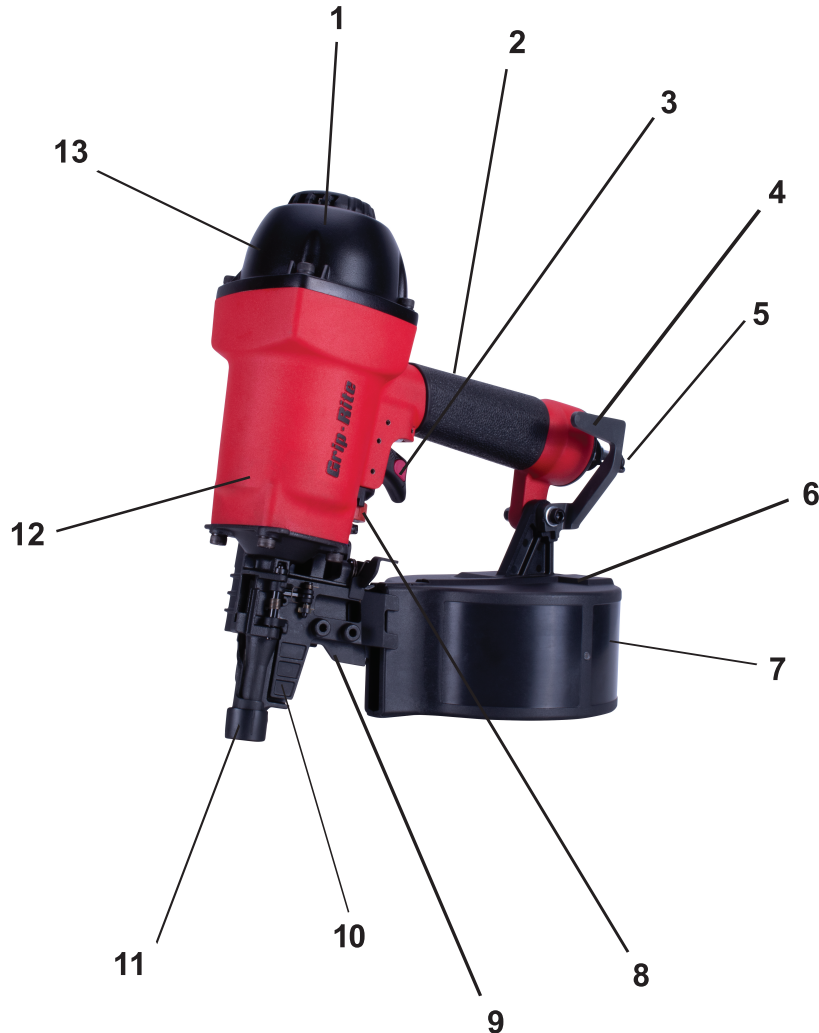

DESCRIPTION

PART DESCRIPTIONS

- 1. 360° Adjustable Air Deflector** - Tool-free adjustment blows exhaust air away from operator.
- 2. Cushioned Grip** - Cushioned handgrip reduces fatigue and provides comfortable operation.
- 3. Switchable Trigger (Contact Trip)** - Actuates tool when workpiece contact is depressed against work surface. Permits contact-trip (bump fire) or trigger-fire operation.
Switchable Trigger (Sequential) - Actuates tool only when correct trigger operating sequence is followed. Does not allow bump firing.
- 4. Belt Hook** - Durable tool hook slides on belt. Holds tool securely and keeps it in reach for greater productivity.
- 5. Air Coupling** - Quick-disconnect male coupling allows quick connection to air hose. Dust cap keeps dirt out when tool is not in use.
- 6. Safety Warning Label** - Provides important safety reminders that must be followed whenever handling, operating, or servicing the tool.
- 7. Coil Nail Magazine** - Hold fasteners securely and protects coils from damage.
- 8. Adjustable Depth of Drive** - Tool-free depth of drive adjustment allows nail drive adjustments to be made at tool for consistent depth control.
- 9. Door Latch** - Spring-loaded latch keeps door securely closed. Opens quickly for fast, easy reloading of nail coils.
- 10. Feed Pawl System** - Feed pawl system provides consistent nail feed.
- 11. Workpiece Contact** - Spring-loaded contact mechanism prevents tool from driving a fastener unless tool is pressed down and held against a work surface. Removable no-mar pad protects work surfaces.
- 12. Tool Housing** - Magnesium tool housing reduces tool weight
- 13. Cap** - Seals tool housing.
Metric Hex Wrenches - Included with tool to allow tightening of metric screws. Keep tools in tool case for periodic tightening of screws.
Air Tool Oil - Lightweight oil formulated for use in air tools provides proper lubrication to o-rings and internal parts.
Safety Goggles - Provide required eye protection

OPERATION

LOADING FASTENERS

LOADING INSTRUCTIONS



A fastener can be driven unintentionally if the trigger and safety bracket are activated at the same time. Always disconnect tool from air supply before loading fasteners, making adjustments, or performing any service on tool. Keep finger off trigger until ready to drive a fastener.

1. Depress door latch (A) and open door. Swing magazine cover (B) open.

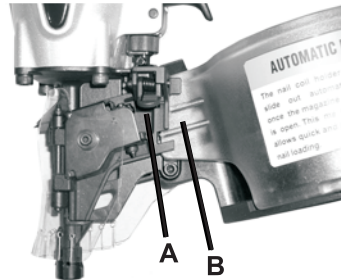

2. Uncoil enough nails to reach drive channel, and pull out toward tool nose.

3. Place first nail in nail drive channel (C), and position second nail between teeth of feed pawl

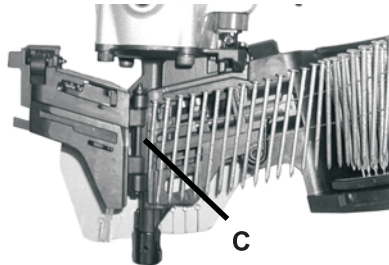

4. Close magazine cover, and latch door securely.

7. Nailer is now loaded and ready to be connected to an air supply for operation.

OPERATION

ADJUSTING NAIL DRIVE

1. Disconnect tool from air supply using quick-connect coupling.
2. Turn adjustment dial backward to increase nail drive, or forward to decrease nail drive, as shown by nail symbols on tool.
3. Connect tool to air supply, and drive nails to check for correct depth of drive.
4. Make depth of drive adjustments as needed to maintain consistent nail driving.

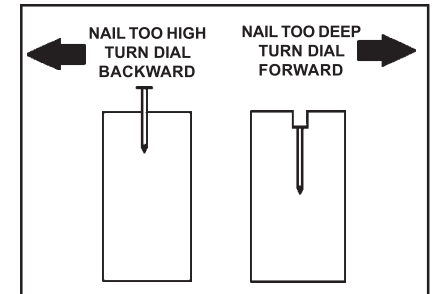
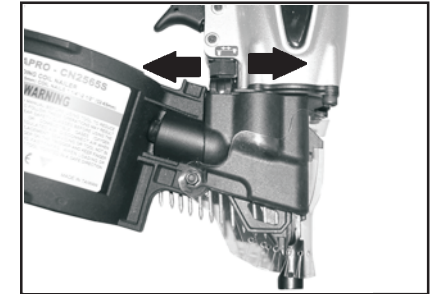

CLEARING NAIL JAMS

1. Disconnect tool from air supply using quick-connect coupling.
2. Open door, remove nails from drive channel and feed pawl.
3. Insert rod into nose bore, and push nail back through drive channel and out of guide body. If necessary, tap rod lightly with a hammer to free jammed nail.
4. Remove nail from drive channel using pliers.

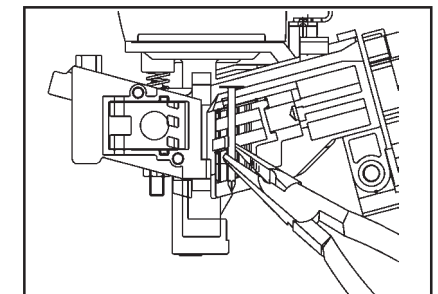
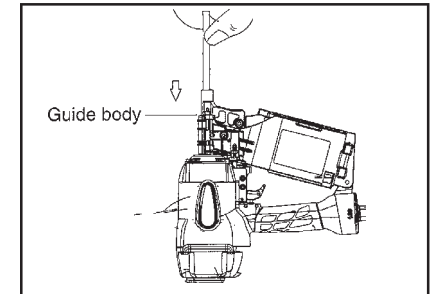

OPERATION

TOOL OPERATION

CONTACT TRIP (BUMP FIRE) DRIVING METHOD

1. Position the nose of the tool over the work surface, near the area where the first fastener is to be driven.
2. Squeeze and hold the trigger in the depressed position.
3. Bump the workpiece contact (safety) against the work surface at each point where a fastener is to be driven.
4. Using a bouncing motion, continue moving the tool into position for each fastener drive.
5. When fastening is completed, release the trigger.

SEQUENTIAL OPERATION

To operate this tool in sequential mode, position the red trigger selector to the single nail position (sequential position).

1. Hold the tool securely using the handgrip. Keep finger off trigger until tool is in position and you are ready to drive a fastener. **NOTE:** Depressing trigger before depressing safety bracket will prevent tool from actuating.
2. Position the nose of the tool on the workpiece, placing the nose at the desired fastener driving position.
3. Press the tool down firmly against the work surface, fully depressing the workpiece contact (safety bracket).
4. Squeeze the trigger once to drive a fastener.
5. Allow the tool to rebound off the work surface, and release the trigger to reset the workpiece contact. Tool will not drive another fastener until trigger is released, and cannot be bump-fired with sequential trigger installed.
6. Check fastener for flush drive, and if needed, turn nail depth adjustment dial to obtain desired fastener drive.
7. If tool adjustments do not provide the desired results, make air pressure adjustments at the compressor: Increase air pressure to drive deeper or to drive into harder materials. Reduce air pressure to reduce drive or to drive into softer materials. For longest tool and part life, always use the lowest air pressure necessary to drive fasteners to desired depth.
8. Position the tool for driving the next fastener, and repeat the above procedure. Always keep hands and other body parts away from areas being fastened.

MAINTENANCE

MAINTENANCE

Your tool will last longer and perform better if periodic maintenance is performed. Please use the information below to keep your tool operating in top condition.

Lubrication

Disconnect tool from the air supply and remove all fasteners. Apply 2 - 3 drops of air tool oil (provided) in the air inlet two - three times a day. If the tool will be used outside in the winter, use a winter grade air tool oil to help keep frost from forming inside the tool. Do not use other types of lubricants on this tool, as other lubricants may contain chemicals harmful to o-rings and other tool components. Drain compressor tanks and hoses daily.

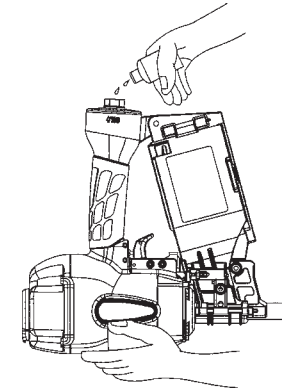

Cleaning

Disconnect tool from the air supply and remove all fasteners. Brush tool off using a parts cleaning brush or clean rag. Open feed pawl door and magazine cover, and brush out dirt and debris. Check area around trigger and workpiece contact, and clean as necessary.

Trigger Check

Check trigger operation daily to confirm proper sequential operation:

1. Press the workpiece contact against a safe work surface without depressing the trigger. **THE TOOL MUST NOT CYCLE.**
2. Hold the tool above a safe work surface and pull the trigger without depressing the workpiece contact. **THE TOOL MUST NOT CYCLE.**
3. Pull and hold the trigger, and then press the workpiece contact against a safe work surface. **THE TOOL MUST NOT CYCLE.**
4. With finger off trigger, press the workpiece contact against a safe work surface. Keep tool pressed against work surface, and pull trigger. **THE TOOL MUST CYCLE ONCE.**
5. The trigger must return to the normal position each time finger pressure is released.

PARTS SCHEMATIC

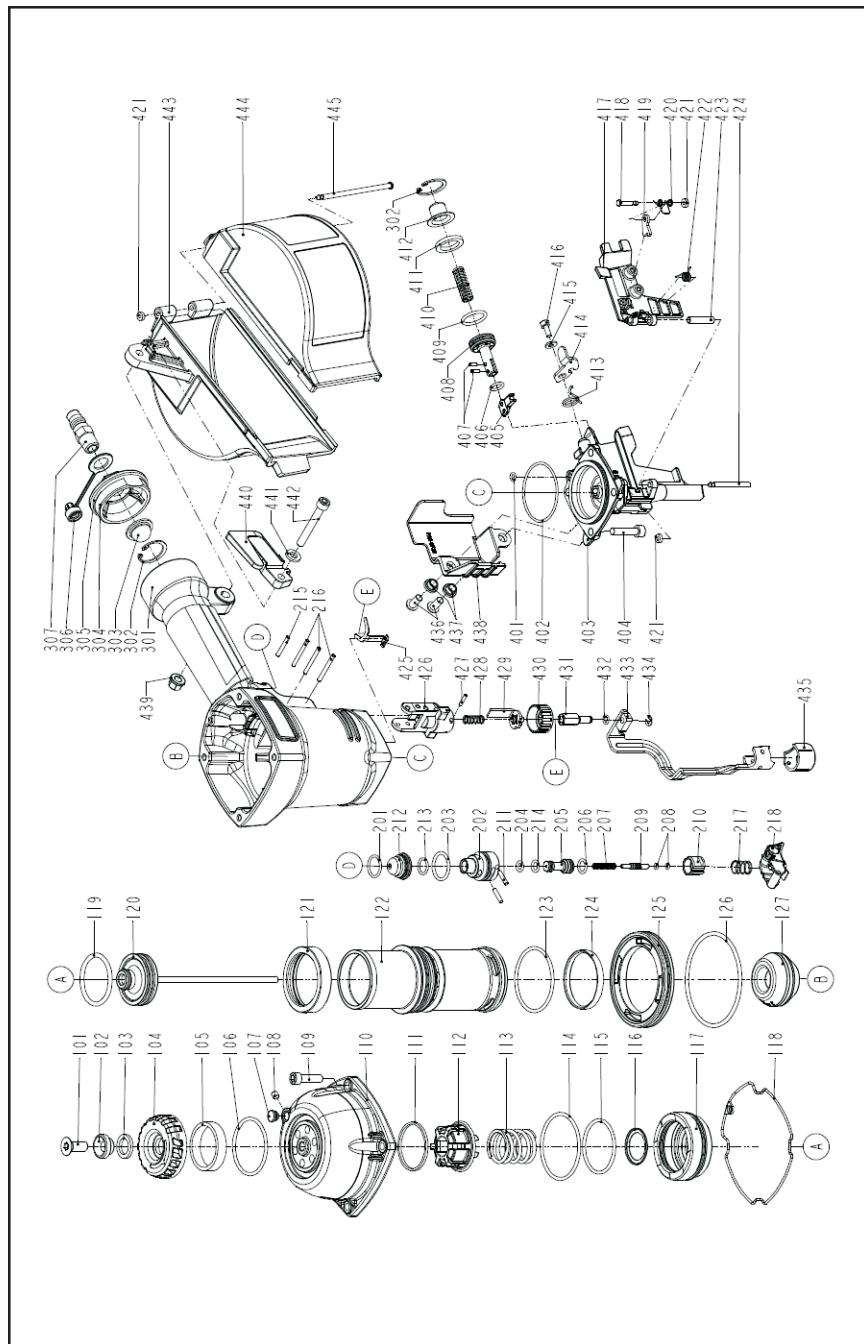

PARTS LIST

Item#	Part #	Description	Q'ty
101	GRBN695	COUNTER SUNK SCREW	1
102	GRBN696	WASHER	1
103	GRBN886	RUBBER PAD	1
104	GRBN698	DEFLECTOR	1
105	GRBN699	MUFFLER	1
106	GRBN700	O - RING	1
107	GRBN618	GROMMET	1
108	GRBN305	HEX.SOC.HD.SCREW	1
109	GRBN701	HEX.SOC.HD.BOLT	4
110	GRBN887	CAP	1
111	GRBN680	WASHER SEAL	1
112	GRBN888	SEAL	1
113	GRBN673	COMPRESSION SPRING	1
114	GRBN692	O - RING	1
115	GRBN705	O - RING	1
116	GRBN681	WASHER	1
117	GRBN889	HD.VALVE PISTON	1
118	GRBN890	CYLINDER CAP SEAL	1
119	GRBN708	O - RING	1
120	GRBN891	DRIVER UNIT	1
121	GRBN710	COLLAR	1
122	GRBN892	CYLINDER	1
123	GRBN712	O - RING	1
124	GRBN713	CYLINDER RING	1
125	GRBN714	CYLINDER SPACER	1
126	GRBN715	O - RING	1
127	GRBN716	BUMPER	1
201	GRBN588	O - RING	1
202	GRBN556	PLUNGER CAP	1
203	GRBN582	O - RING	1
204	GRBN421	O - RING	1
205	GRBN527	VALVE PLUNGER	1
206	GRBN423	O - RING	1
207	GRBN424	SPRING	1
208	GRBN592	O - RING	2
209	GRBN557	PLUNGER	1
210	GRBN893	TRIGGER VALVE HEAD	1
211	GRBN518	PIN	2
212	GRBN560	COVER-PLUNGER	1
213	GRBN589	O - RING	1
214	GRBN580	O - RING	1
215	GRBN458	SPRING PIN	1
216	GRBN428	SPRING PIN	3
217	GRBN558	SPRING	1
218	GRBN504	TRIGGER UNIT	1
301	GRBN894	GUN BODY UNIT	1
302	GRBN895	C - RING	2
303	GRBN896	FILTER	1
304	GRBN897	END CAP	1

Item#	Part #	Description	Q'ty
305	GRBN430	O - RING	1
306	GRBN605	AIR PLUG CAP	1
307	GRBN620	AIR PLUG	1
401	GRBN646	O - RING	1
402	GRBN721	O - RING	1
403	GRBN898	NOSE PIECE	1
404	GRBN688	HEX.SOC.HD.BOLT	4
405	GRBN899	FEED FINGER	1
406	GRBN900	O - RING	1
407	GRBN901	SPRING PIN	2
408	GRBN902	FEED PISTON	1
409	GRBN903	O - RING	1
410	GRBN904	PUSHER SPRING	1
411	GRBN905	FEED BUMPER	1
412	GRBN906	FEED PISTON CAP	1
413	GRBN907	LATCH SPRING	1
414	GRBN908	DOOR LATCH	1
415	GRBN33	FLAT WASHER	1
416	GRBN230	HEX.SOC.HD.BOLT	1
417	GRBN909	DOOR	1
418	GRBN910	PIN-NAIL STOP	1
419	GRBN911	NAIL STOP	1
420	GRBN912	STOPPER FINGER SPRING	1
421	GRBN540	PU RETAINER	3
422	GRBN913	SPRING	1
423	GRBN914	LATCH SPRING BUSHING	1
424	GRBN915	DOOR SHAFT PIN	1
425	GRBN916	STOPPER	1
426	GRBN666	SAFETY GUIDE	1
427	GRBN69	SPRING PIN	1
428	GRBN665	SAFETY SPRING	1
429	GRBN506	SAFETY B UNIT	1
430	GRBN565	ADJUST AXIE	1
431	GRBN917	ADJUST ROD	1
432	GRBN587	O - RING	1
433	GRBN918	SAFETY A UNIT	1
434	GRBN576	E - RING	1
435	GRBN524	PROTECTIVE CASING	1
436	GRBN919	HALF ROUND HD.HEX.BOLT	2
437	GRBN920	PROTECTIVE INSERT	2
438	GRBN921	SAFETY COVER	1
439	GRBN579	BOLT CAP	1
440	GRBN526	SPRING RETAINER	1
441	GRBN922	FLAT WASHER	1
442	GRBN923	HEX.SOC.HD.BOLT	1
443	GRBN924	MAGAZINE CASE	1
444	GRBN925	MAGAZINE COVER	1
445	GRBN926	MAGAZINE SHAFT PIN	1

- A GRDAK2600 Drive Assembly Kit
- B GRRBK2600 Rebuild Kit
- C MANCS250Z Operators Manual

TROUBLESHOOTING

TOOL TROUBLESHOOTING

Your pneumatic fastening tool has been designed for long life and trouble-free operation. However, if operating problems arise, please use the troubleshooting information below to determine how to remedy the problem.

DANGER

Always disconnect tool from air supply before performing any service on tool. Correcting a problem while the tool is pressurized may result in injury from fastener discharge or tool operation.

FASTENER DRIVING PROBLEMS

PROBLEM	CORRECTIVE ACTION
Fasteners do not drive completely.	AT TOOL: Turn adjustment dial to increase nail drive depth. Add 2 - 3 drops of air tool oil to inlet.
	AT COMPRESSOR: Increase air pressure. Do not exceed 120 psi/8.3 bar
Fasteners do not drive completely after air pressure is increased.	Driver blade worn or broken. See dealer for replacement.
Fasteners do not drive completely when driving in quick succession.	Inadequate air flow. Use larger diameter hose. Use compressor with larger storage tank. Keep hose lines short. Check air hose for kinks or other restrictions.
Fasteners drive too deeply.	AT TOOL: Turn adjustment dial to decrease nail drive depth.
	AT COMPRESSOR: Reduce air pressure. (Do not reduce below 70 psi/4.8 bar.)

TROUBLESHOOTING

FASTENER DRIVING PROBLEMS

Tool operates, but no fastener is driven.	Check coil for broken collation media. Cut off broken section and discard. Check tray setting for correct nail size. Reload nails.
Tool won't operate - nail jammed in tool nose, preventing tool from operating.	Depress magazine release, and open magazine. Remove jammed fastener. Check magazine for obstructions, debris, and loose fasteners. Discard loose fasteners. Check tray setting for correct nail size. Reload nails.
Tool leaks air.	Check for source of leak, and tighten fittings and screws as required. Discontinue using tool if air leaks at trigger area or from cap exhaust. Contact your dealer.

TOOL CHECKS

Keep your nailer in top working condition by checking it daily. See your Grip-Rite™ dealer for service if part or operating problems are found. Never use a malfunctioning tool - it could result in serious injury.

Workpiece Contact & Trigger

Check workpiece contact for proper operation before each use. Workpiece contact must move freely and return to extended position when lifted from workpiece. Trigger must operate freely.

Daily Inspection

- Check for broken, damaged, or excessively worn parts, and repair or replace as needed.
- Check for air leaks at trigger, cap, and nose. Disconnect tool from air supply immediately if leaks are present, and see dealer for service.
- Make sure all screws are tightened securely.



LIMITED WARRANTY APPLICABLE TO PNEUMATIC TOOLS AND COMPRESSORS

GRIP-RITE® brand pneumatic tools bearing Serial Numbers 19070001 and above; or Serial Numbers 19400001 and above, are warranted to be free from defects in workmanship and materials for seven years from the date of purchase.

Rubber o-rings, bumpers, seals, driver blades, dipsticks, and air filters are excluded from this warranty. Pneumatic tools bearing Serial Numbers not reference above, including all legacy branded tools or “silver body” tools, are covered by a three-year warranty.

All compressors, regardless of body color, are warranted to be free from defects in materials and workmanship for one year from the date of original purchase.

If your compressor or GRIP-RITE™ pneumatic tool demonstrates a defect in workmanship or materials during the warranty period, it may be returned to PRIMESOURCE® for repair, and if it is not repairable, PRIMESOURCE® will replace it.

These warranties will not apply if:

- The original receipt (or copy), showing the original purchase date, is not provided with the tool or compressor sent in for warranty repair
- The tool or compressor has been misused, abused or improperly maintained
- Alterations have been made to the original tool or compressor
- Repairs have been attempted or made to the original tool or compressor by any entity other than a proprietary PRIMESOURCE® service/warranty center or authorized service/warranty center
- Non-GRIP-RITE TOOLS™ / GRIP-RITE COMPRESSORS™ parts have been used
- The tool has suffered any physical damage due to the use of non-PRIMESOURCE® approved fasteners. The only approved fasteners include the following brands TIMCO, GRIP-RITE
- Repairs are required due to normal wear and tear on the product. Normal wear and tear are not warrantable conditions
- The tool or compressor has been inadequately packaged leading to damage in transit to the service/warranty center

THESE WARRANTIES ARE IN LIEU OF ALL OTHER WARRANTIES EXPRESS OR IMPLIED. PRIMESOURCE® EXPRESSLY DISCLAIMS ALL OTHER WARRANTIES, INCLUDING WARRANTIES OF MERCHANTABILITY AND FITNESS FOR A PARTICULAR PURPOSE (EXCEPT AS MAY OTHERWISE BE PROVIDED BY LAW).

PRIMESOURCE® DISCLAIMS LIABILITY FOR INDIRECT, INCIDENTAL, OR CONSEQUENTIAL DAMAGES RELATED TO THE SALE OR USE OF ITS PRODUCTS BOTH DURING AND AFTER THE WARRANTY TERM.

These warranties give you specific legal rights, and you may also have other rights, which vary, from state to state.

(continued on next page)

PNEUMATIC TOOL/COMPRESSOR SERVICE INFORMATION

Should any mechanical problems develop during the life of your equipment, the following options are available for service and parts:

- Call (800) 676-7777 to be routed to the nearest GRIP-RITE™ distribution center and directed to the nearest authorized service/warranty center
- Log on to our website at www.grip-rite.com to find a list of our authorized service centers
- Contact the PRIMESOURCE® National Service Center directly at Phone: (800) 207-9259 or Fax: (800) 207-9614

STEPS TO TAKE WHEN SHIPPING TOOLS

- Adequately package the product to avoid damage in transit (in the case of pneumatic tools, the original blow mold plastic carrying case is considered adequate packaging)
- Provide the original or copy of the receipt showing the original purchase date
- Insure your shipment with the shipping company. PRIMESOURCE® will not be responsible for any tool or compressor that is lost or damaged by the shipper.

**USE GENUINE GRIP-RITE®
FASTENERS FOR BEST
PERFORMANCE**



Distributed by/Distribuido por:

PRIMESOURCE®
BUILDING PRODUCTS, INC.

Irving, Texas 75038 USA
www.primesourcebp.com

Made in Taiwan
Hecho en Taiwn

Imported by/Importé par:

PRIMESOURCE®
BUILDING PRODUCTS CANADA CORPORATION

Irving, Texas 75038 USA
www.primesourcebp.com

Made in Taiwan
Fabriquè a Taiwan