

## USE AND CARE GUIDE

---

### STONE GREY DINING CHAIR(SET OF 2)

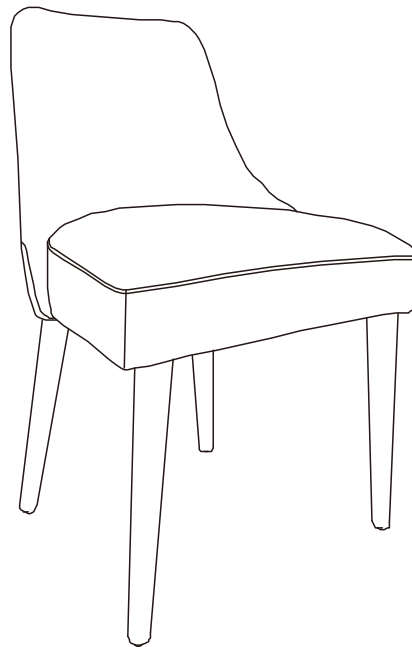

Questions, problems, missing parts?  
Before returning to the store, call StyleWell Customer Service  
8 a.m. - 7 p.m., EST, Monday-Friday, 9 a.m. - 6 p.m., EST, Saturday

**1-877-527-0313**

**HOMEDEPOT.COM**

*THANK YOU*

*We appreciate the trust and confidence you have placed in StyleWell through the purchase of this STONE GREY DINING CHAIR(SET OF 2). We strive to continually create quality products designed to enhance your home. Visit us online to see our full line of products available for your home improvement needs. Thank you for choosing StyleWell!*

# Table of Contents

Table of Contents .....	2	Hardware Included .....	3
Safety Information.....	2	Package Contents .....	4
Warranty .....	2	Assembly .....	5
Type of Warranty .....	2	Troubleshooting.....	7
What is Covered .....	2	Maintenance .....	7
What is Not Covered .....	2	Care and Cleaning .....	7
Pre-assembly .....	3		
Planning Assembly .....	3		

# Safety Information

Please read and understand this entire manual before attempting to assemble the product. If you have any questions regarding the product, please call customer service at 1-877-527-0313, 8 a.m. – 7 p.m., EST, Monday – Friday, 9 a.m. – 6 p.m., EST, Saturday.

- Read these instructions carefully and retain them for future use. If this product is passed by a third party, then these instructions must be included.
- When using the product, basic safety precautions should always be followed to reduce the risk of injury including the following:
  - Ensure there are no missing parts prior to assembly.
  - Assemble the product on carpet to prevent damage.
  - Be careful not to cross-thread screws and do not use power tools.
  - Before using the product, ensure that it is completely and properly assembled.
  - Assembly is to be carried out by competent adults only.
- During assembly children should be kept away from the product to avoid possible risk of injury.
- Keep all hardware parts away from children.
- Dispose of plastic packaging material immediately to avoid any risk of suffocation.
- Regularly check screws to ensure they are tightened securely.



**WARNING:** Keep all hardware parts away from children.



**WARNING:** Before assembly, carefully use scissors or utility knife to cut and unwrap all parts. Make sure you do not discard the hardware.



**WARNING:** Dispose of plastic packaging material immediately to avoid any risk of suffocation to children and animals.

# Warranty

## 1 YEAR WARRANTY

### WHAT IS COVERED

We guarantee this product to be free of manufacturing defects to the original purchaser for one year.

### WHAT IS NOT COVERED

This warranty does not cover commercial use, acts of nature, and abusive use.

Contact the Customer Service Team at 1-877-527-0313 or visit [HOMEDEPOT.COM](http://HOMEDEPOT.COM).

# Pre-assembly

## PLANNING ASSEMBLY

- Remove all packaging materials.
- Refer to the parts and hardware lists, and ensure all parts and hardware are present before assembly.
- Contact customer service for missing parts.
- Place all wooden parts on a clean, flat and soft surface (e.g. carpet or rug) to prevent scratch and damage to parts.

## ASSEMBLY TOOL



INCLUDED IN HARDWARE PACK

## HARDWARE INCLUDED



NOTE: Hardware not shown to actual size.

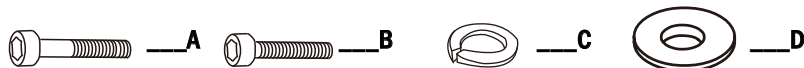

Part	Description	Quantity
A	Screws (M8x60 mm)	4
B	Screws (M8x55 mm)	4
C	Washers	8
D	Lock Washers	8

# Pre-assembly (continued)

## PACKAGE CONTENTS

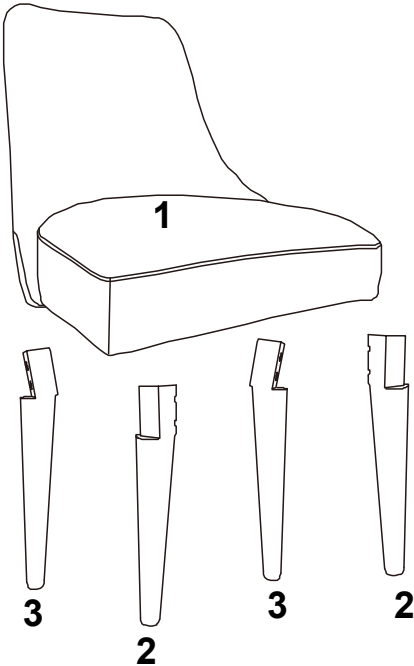

Part	Description	Quantity
1	Back rest	1
2	Front Leg	2
3	Back Leg	2

# Assembly

## 1 Attaching the legs

- Fasten the front legs (2) into the seat with screws (A) and washers (C) and lock washers(D) to 60%.

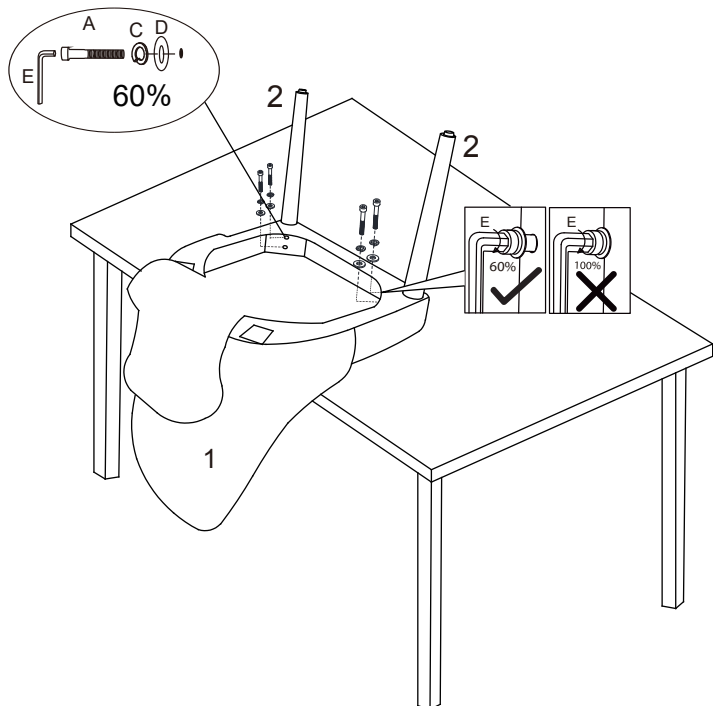

## 2 Fastening the legs

- Fasten the back legs (3) in to the seat with screws (B) and washers (C) and lock washers(D) to 60%.

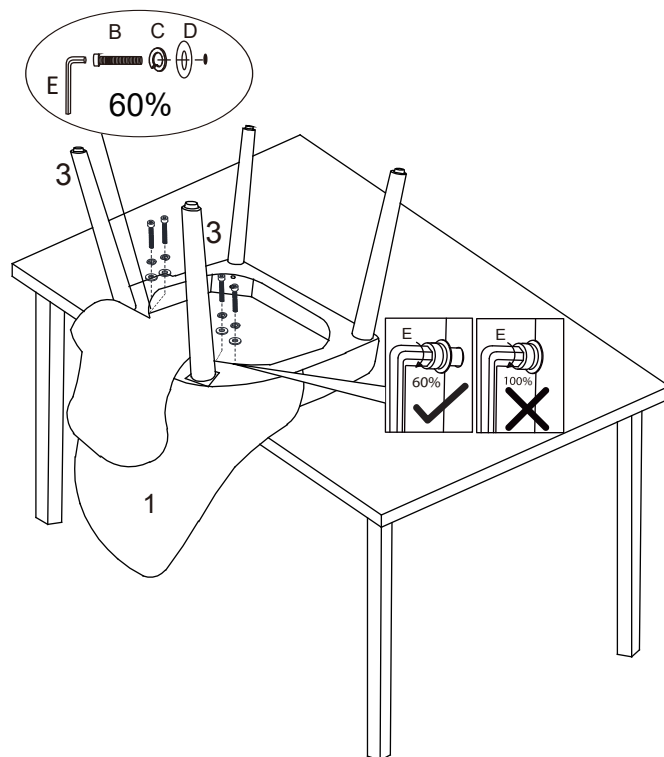

## Assembly (continued)

### 3 Level the chair/Tightening up all screws

- Place the chair on a level surface and keep 4 legs straight down on the floor, then tighten up all screws to 100%.

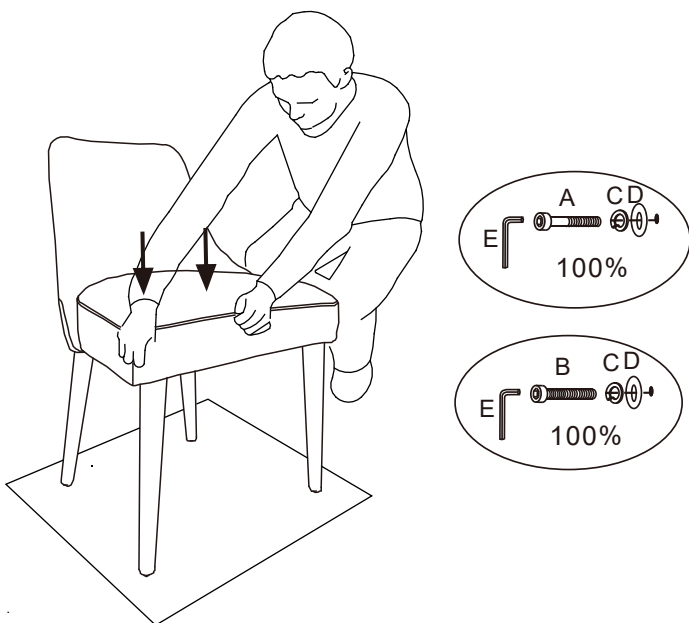

### 4 Zipping up

- Zip up the seat cover .

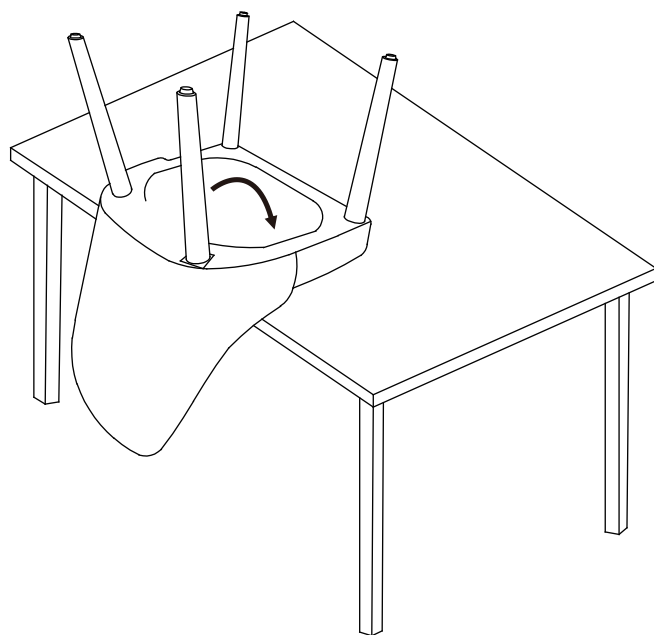

# Troubleshooting

PROBLEMS	SOLUTION
Rung not fit into the leg / wobbly/not level.	According to the parts label on the Instruction Runner, check whether the wooden legs or rung are installed in the wrong direction.
	If they are wrong, re-assemble according to the correct part label on the Instruction Runner.
	For dining chair, lock the screws to 60% first, then tighten the screws to 100% after put on a level platform.
	For barstool, lock the screws to 60% first, then should 100% lock the rung, finally tighten the screws to 100% after put on a level platform.

# Maintenance

- Check all screws and nuts periodically for tightness, fastening them again as required.
- Disassemble the product in the reverse order of the assembly steps.
- Always disassemble the product completely. A partially-disassembled product is not stable enough to sit on, and therefore can be damaged or cause injury.
- For cleaning, use water or mild detergent. Do not use solvent-type cleaning agents.
- Periodically (every 90 days) make sure that the screws are fully tightened.

# Care and Cleaning

- For washing the seat, use water or mild detergent. If there is solvent on it, clean with a dry cloth and water.
- Does not use bleach, acid, or other abrasive cleaners on the frame parts.
- Metal components of indoor furniture are treated with powder coating. Surface oxidation (rusting) will occur if the coating is scratched. To minimize:
  - It is recommended that care be taken when assembling and handling the product in order to prevent the paint from being scratched.
  - Surface rust can be removed easily using a very light application of common cooking oil.
  - If surface oxidation (rusting) occurs and no measures are taken to correct it, the oxidation may start dripping onto the assembly surface, which may cause damaging stains that may be difficult to remove.

# **StyleWell™**

Questions, problems, missing parts?  
Before returning to the store, call StyleWell Customer Service  
8 a.m. – 7 p.m., EST, Monday-Friday, 9 a.m. – 6 p.m., EST, Saturday

**1-877-527-0313**

**HOMEDEPOT.COM**

Retain this manual for future use.