

SHELTER FURNACE

**WOOD BURNING
INDOOR FURNACE**

MODELS: SF2600, SF3100



**Manufactured by:
Shelter Furnace
10950 Linpage Place
Saint Louis, MO 63132
1-800-875-4788**

MADE IN USA



Intertek
Tested to
UL391 and
CSA B366.1-2011
and B415.1-2010
Standards

PROPER BURN PRACTICES **FOR MAXIMUM EFFICIENCY AND SAFETY!**

- The chimney is one of the most important elements of the furnace. If the chimney is not connected properly and installed according to manufacturer's specification and national and local codes, the unit is not safe and will not burn efficiently. Lack of proper chimney installation will cause unit to produce more smoke and less heat output. See Pages 7-9 of this manual to ensure proper installation.
- Proper use of all electrical components is essential: For instance, the wall thermostat must be hooked up to the furnace and the draft blower must be in operation at all times. This will increase furnace efficiency and produce more heat output.
- Wood that is properly cut and stored to dry will produce more BTUs and higher heat output than wood that has a higher moisture content. Wood with higher moisture content will create creosote in the chimney and cause flue fires.
- There should be no alteration of the Shelter Furnace in any way, as this will void the UL391 listing and affect the operation of the furnace. This will also void the warranty of the unit.
- Shelter Furnace makes two types of units, indoor as well as outdoor furnaces. The indoor units are manufactured and tested for indoor applications only. They are not meant to go outside the house but must be placed indoors in a basement or utility room. Any indoor unit placed outside the home in a shed or building will void warranty, violate the safety listing, and will not produce the maximum efficiency possible with this unit. For outdoor applications please use unit SF4200.



SHELTER INDOOR FURNACE MANUAL

MODELS: SF2600, SF3100

EPA Certified to the Warm Air Furnace NSPS requirements, for sale May 2017 through May 2020.

SAVE THESE INSTRUCTIONS

Congratulations! You have selected the finest quality wood burning indoor furnace, manufactured with pride in the USA. Please take a few moments to carefully read the owner's manual. By taking the time to familiarize yourself with your new Shelter Furnace, you will be able to look forward to years of trouble-free, dependable service.

Installation:

First: Check local codes. The installation must comply with all local rules and requirements.

Furnace installation is to be performed by a qualified installer. This furnace must not be installed in trailers, modular or mobile homes. Always have a properly installed and functioning smoke detector in your home. To prevent accidental injury, do not allow anyone who is unfamiliar with the furnace to operate it. **Spend time familiarizing yourself with your Shelter Furnace, especially the different settings and the effects they have on burn patterns.** It is impossible to predict how each setting will affect your furnace due to variations in conditions, fuels and temperatures.

Transportation Damage:

Every effort has been made to ensure that your Shelter Furnace will arrive in perfect condition. Any visible damage should be noted on the freight bill at the time of delivery. If upon unpacking your Shelter Furnace you find damage has occurred during transit, notify your supplier immediately. Your supplier will advise you what actions must be taken to address the problem.

Disclaimer Notice:

The listed BTU rating for your new Shelter Furnace was obtained using laboratory calculations. **The actual BTU output you experience may vary somewhat depending on the type, condition and moisture content of the fuel used, damper adjustment, chimney type and other factors.** Therefore, the manufacturer disclaims any guarantee as to the BTU output or capacity. Shelter Furnace disclaims any responsibility for the following: installation of a furnace that has been altered or modified in any way; installation of the furnace other than as instructed in this manual; installation and/or use of any component or part not approved by Shelter Furnace for use with this furnace. Be sure to complete and return your warranty card within 30 days of purchase in order to activate warranty coverage on your furnace.

Manufacturer's Notice:

Please be advised that we periodically make changes to improve our products, therefore the information in this manual may not be completely applicable to your Shelter Furnace. Please refer to markings on the appliance for additional information.

**THIS IS A WOOD BURNING FURNACE ONLY AND SHOULD NOT BE ALTERED
IN ANY WAY.**

TABLE OF CONTENTS

General Information _____	3
Location and Installation _____	3
Assembly of Unit _____	4
Blower and Housing _____	5
Filter Box _____	6
Chimney Types and Recommendations _____	7
Duct Runs _____	9
General Operation _____	10
<u>TYPES OF WOOD TO USE</u> _____	10
<u>FIRST FIRE</u> _____	12
<u>LOADING WOOD</u> _____	12
Disposal of Ashes _____	13
Draft Blower _____	13
<u>CREOSOTE FORMATION</u> _____	13
<u>CREOSOTE PREVENTION</u> _____	13
Chimney Fire Warning _____	14
Power Failure _____	14
Furnace Diagram with Parts List _____	15
Grate System Diagram - SF2600 _____	16
Grate System Diagram - SF3100 _____	16
Blower Motor Assembly Diagram _____	17
Wiring Diagram _____	18
Troubleshooting _____	19
Warranty Information _____	24

DOUBLE CHECK TO MAKE SURE YOU HAVE RECEIVED ALL OF THE REQUIRED COMPONENTS. IF YOU FIND THAT THERE IS A PART MISSING, CALL 1-800-875-4788 FOR FASTEST SERVICE, PLEASE DO NOT GO BACK TO THE STORE. STORE DOES NOT HAVE REPLACEMENT PARTS.

General Information

The Shelter EPA-Approved Furnace has been engineered to accommodate the heating requirements of the average sized home, even during winter's coldest months, with a heat output range up to 140,000 BTUs. It is constructed with high grade, heavy gauge steel and is continuously welded to assure the highest structural strength. In addition, the firebox is lined with insulated stainless steel panels to ensure many years of energy efficient service. The design of the secondary combustion chamber increases fuel efficiency by creating a "secondary burn" of smoke and wood gases before they are vented up the chimney. The cast iron doors are custom fitted to provide an airtight seal, greatly extending the burn time and ensuring maximum efficiency in fuel consumption. The heavy-gauge cast iron grate, designed for maximum heat transfer, allows for convenient ash removal and reduced maintenance.

For total comfort and convenience, a thermostatically controlled draft and circulation blower system is included. These fully automatic components furnish rapid heat disbursement throughout your home, minimizing recovery time when the wall thermostat demands heat.

All of these features are standard, offering you the most efficient, durable and affordable indoor wood burning furnace.

Efficiency was determined using the higher heating value of the fuel per B415.1-10 testing requirements. Dry seasoned wood will develop greater BTU output. A well-insulated dwelling will always lead to better results and overall improved fuel usage efficiency.

Your Shelter Furnace is designed to be either a supplemental or central heating source for your home. This wood burning furnace may be installed in parallel with a properly operating electric, gas or oil-fired central furnace, listed or certified in accordance with a nationally recognized safety standard, and within clearances specified on the nameplate. When in a parallel installation the static pressure of the central furnace plenum may not exceed 0.15 water column inches and the maximum setting on central furnace limit switch is 182°F. With the Shelter Furnace in an "Interconnection Arrangement" your furnace should be upstream of the central furnace. The Shelter Furnace warm air supply should never be connected to return air for the central furnace. A qualified installer should perform the installation. This wood heater needs periodic inspection and repair for proper operation. It is against federal regulations to operate this wood heater in a manner inconsistent with operating instructions in this manual.

IMPORTANT: FOR TECHNICAL SUPPORT OR CUSTOMER SERVICE ISSUES, DO NOT RETURN TO THE STORE (THE STORE DOES NOT HAVE REPLACEMENT PARTS), CALL 1-800-875-4788.

Forced Hot Air Circulation:

The plenum size of your Shelter Furnace must not be reduced to less than 100 square inches, and must provide a minimum of 18 inches between the top of your Shelter Furnace and the main trunk connection. The plenum attached to the furnace must be constructed of metal. The warm air supply duct system should be constructed of materials with a minimum temperature rating of 250° Fahrenheit.

Clearances:

Unit must be placed on a non-combustible floor. This floor must extend at least 16 inches in front, 8 inches on either side of fuel loading and ash removal doors, underneath the chimney connector and must extend 2 inches on either side of the chimney connector. The furnace must maintain the following clearances to combustibles:

- Heat plenum = 2 inches
- Chimney connector = 18 inches
- Front = 48 inches
- Rear = 12 inches
- Sides = 6 inches
- Main furnace = 12 inches

These are minimum clearances and should be strictly followed. In the case of a power outage, a dangerous level of heat accumulation may develop. Do not store fuel or other combustible materials within installation clearances.

Location and Installation

NOTE: Before beginning installation, consult proper local authorities regarding local codes governing all such applications and installations.

DO NOT CONNECT THIS UNIT TO A CHIMNEY FLUE SERVING ANOTHER APPLIANCE. Your furnace must be placed on a non-combustible floor. Position the furnace as close to the chimney as possible. Air for combustion must be provided into the room where the furnace is located. Allow air free access to the furnace for combustion and ventilation.

Garage installs are not recommended due to National fire codes. Consult with your local code and insurance company.

When installing an indoor furnace, the heat plenum coming off the top of the appliance can only go up or horizontal to connect into the main supply duct. **Never** run the plenum down as this will create a heat buildup in the furnace causing the blower to short cycle and damage the blower motor and will not be covered under warranty. This is not a down draft furnace and not to be installed as one. If you do not have a basement and the plenum cannot be put in the ceiling, then we recommend our outdoor Shelter Furnace.

RECOMMENDATION: Purchase Chimfex™ Dry Chemical Chimney Fire Extinguisher. These are readily available at most stove shops and hardware stores. Smoke detectors and carbon monoxide monitors should be installed on all levels of your home. Having a fire extinguisher in the furnace room or area is strongly recommended.

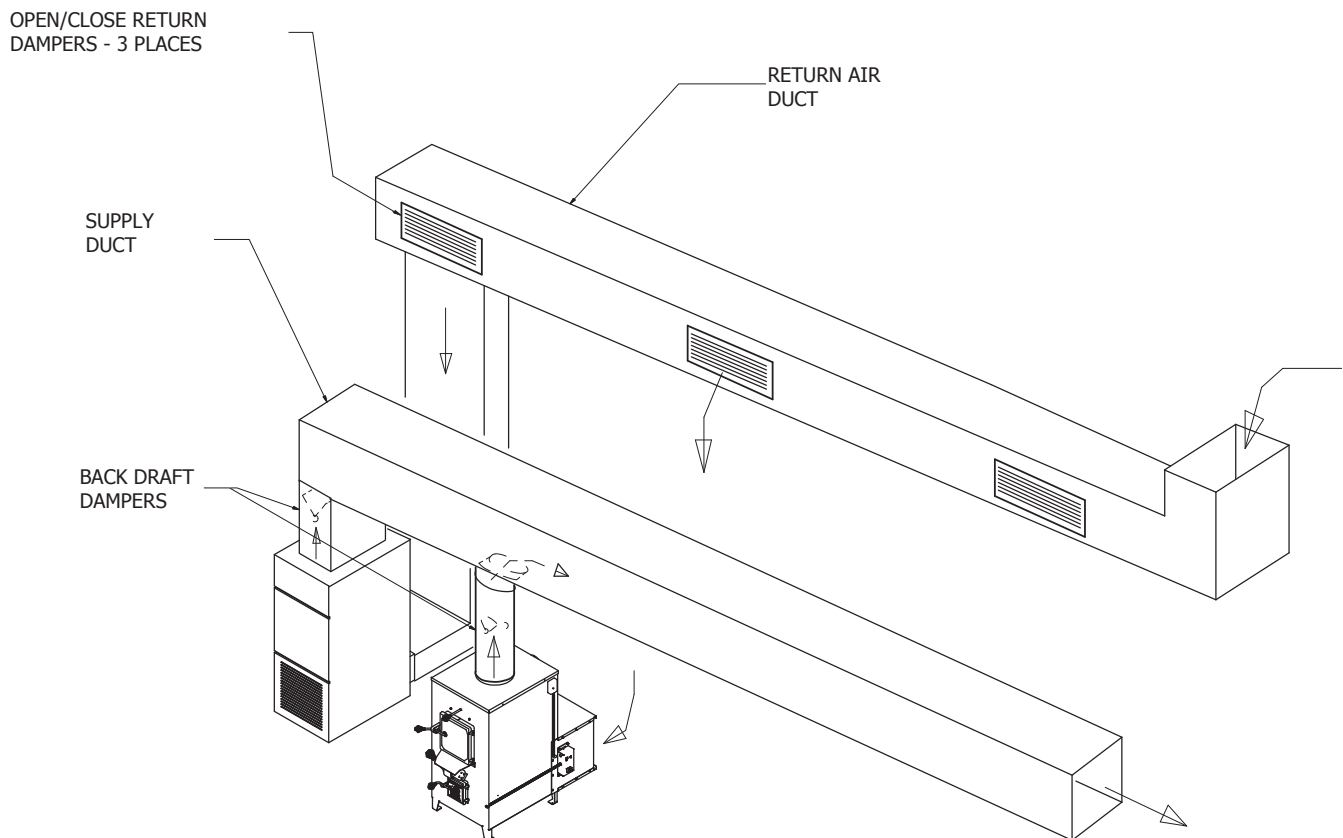

Assembly of Unit

Please review the parts list and diagrams contained on pages 15 - 17 of this manual.

DOUBLE CHECK TO MAKE SURE YOU HAVE RECEIVED ALL THE REQUIRED COMPONENTS. IF YOU FIND THAT THERE IS A PART MISSING, CALL 1-800-875-4788 FOR FASTEST SERVICE, PLEASE DO NOT GO BACK TO THE STORE. STORE DOES NOT CARRY REPLACEMENT PARTS.

NOTE: For your convenience your Shelter Furnace has been factory assembled and the electrical control assembly pre-wired.

1. Fasten the right and left side angle brackets to the circulation blower using (4) 1/4 - 20 bolts and nuts. Line up the blower with the pre-drilled holes on the backside of the furnace, firmly attach with the screws provided.

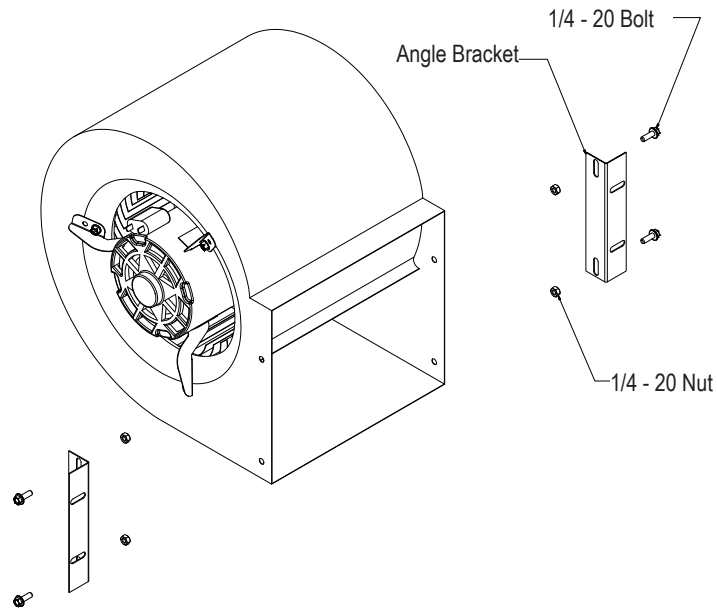

2. Attach blower to the left and right mounting brackets.

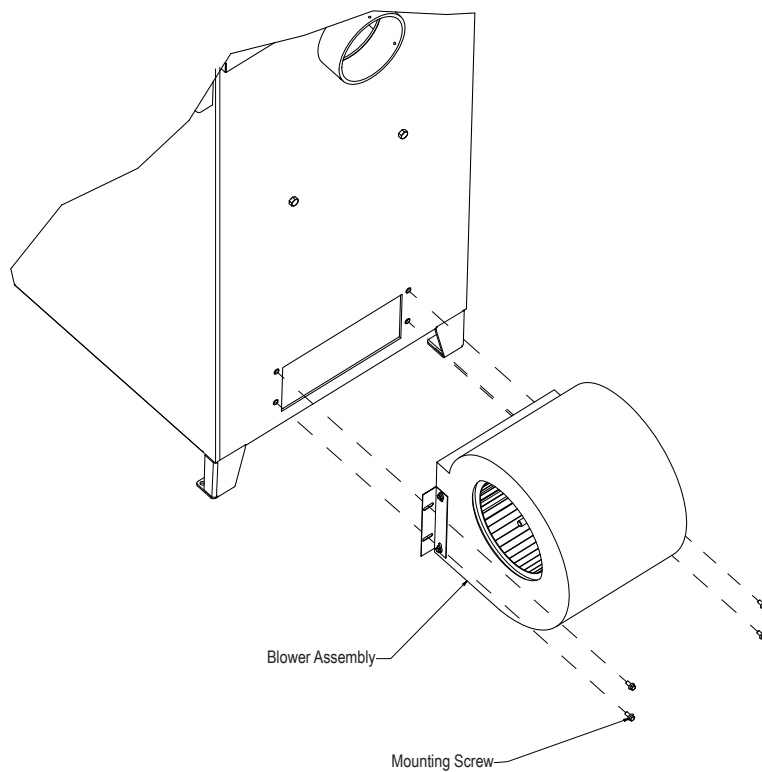

3. Assemble the following parts using 6 #8 sheet metal screws. Both "B" panels should fit inside of "C" and "A" panel flanges. Attach "C" (bottom panel) to "B" (side panels). After the top and sides are assembled, attach "A" (top panel) using 6 #8 sheet metal screws provided.

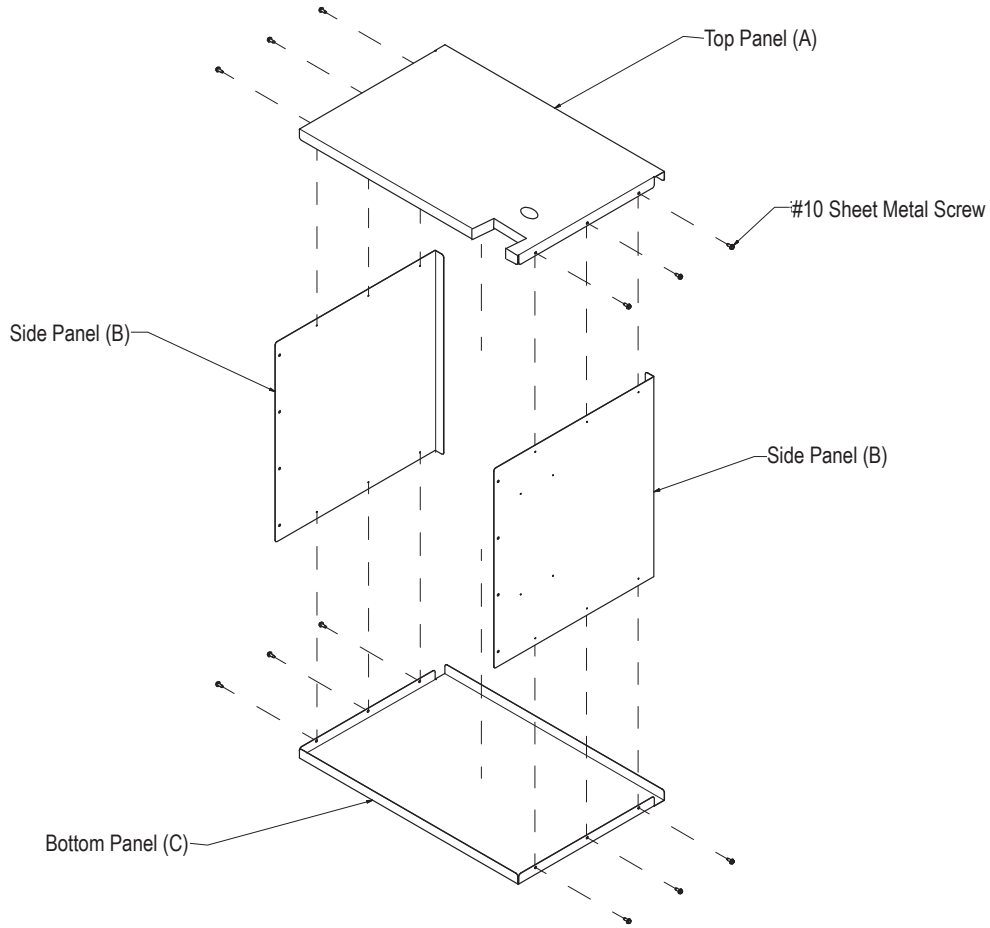

4. Position the assembled filter box on rear of furnace, supporting it firmly up to electrical enclosure covering the rear distribution blower. Make sure the filter box is tightly pressed to the back of the furnace. Use 6 #8 self-tapping screws (included) to firmly attach the filter box to alignment holes on sides of furnace.

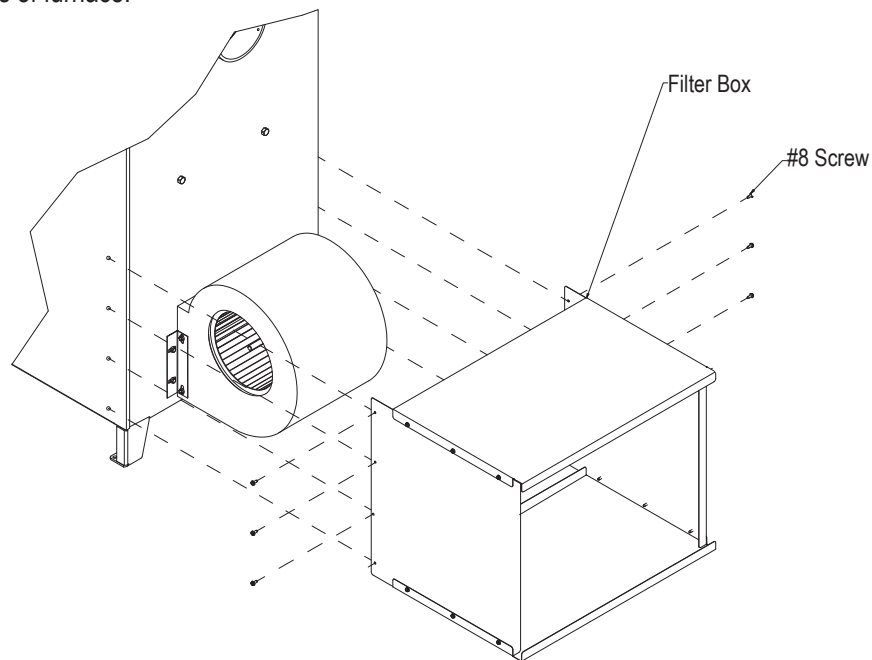

5. Plug motor into the back of the electrical control center.
6. Connect the thermostat wire (not included) to the 2 posts located on the side of the control center. For convenience, you might consider locating the wall thermostat next to your existing thermostat in your home. The thermostat MUST be installed for the furnace to operate.
7. Plug the 3 pronged grounded plug into a grounded electrical outlet..

The filter box requires one 20" x 25" x 1" filter (not included, but available at most hardware and home centers).

See diagram for proper installation filter box. With the connection of the thermostat, chimney pipe and ductwork, your furnace installation is complete.

Inspect your filter regularly and replace the filter every 30 days during heating season for maximum efficiency.

Chimney Types and Recommendations

See Diagram on page 8.

Safety requirements demand that your Shelter Furnace be connected to "Class A" HT2100 All Fuel, or stainless-lined masonry chimney ONLY.

By definition, "Class A" refers to either a lined masonry chimney or all fuel factory-built chimney. Although experts have expressed differing opinions as to which system is the best, it is a matter of what you find most suitable. Regardless of your choice of chimney type, for models SF2600 and SF3100, a minimum 6-inch diameter chimney is needed. In order to create the most effective draft, the chimney size should not exceed 12 inches, with a maximum .08 water column inches of draft. The flue draft can be measured with the use of a draft gage or manometer. If there is more than .08 water column inches of draft, it can be adjusted with the installation of a flue damper. The stovepipe required to connect the furnace to the chimney should be a minimum of 24 gauge black or stainless steel. NEVER USE GALVANIZED PIPE. Horizontal run should not exceed 5 feet and should have a minimum rise of 2 inches per foot. No installation should have more than 2 elbows, a 45° elbow is recommended over a 90° elbow.

As a safety precaution, all pipe selections should be fastened together with a minimum of 3 sheet metal screws. For your convenience, the crimped male ends of the pipe should point toward the furnace to form drip-free connections, thereby reducing the possibility of creosote leakage from the joints. Installing a non-UL-listed heat reclaimer in the pipe is not recommended because it reduces the stack temperature thus causing creosote formation. Installing a manually operated cast iron damper in the stovepipe between the furnace and the chimney pipe is recommended. The addition of a damper will greatly assist in regulating the fire and achieving optimum results. Always install a tee with clean-out cap to the chimney outlet on the back of the furnace. This allows for easier cleaning of the chimney system. Never use a 90° elbow off the back of the furnace.

When using a masonry chimney, you must line the chimney with a stainless steel liner. The stainless steel liner will keep the chimney temperature hotter for better draw and significantly reduce the creosote formation in the chimney. If using this method, a 6-inch stainless liner should be used for models SF2600 and SF3100.

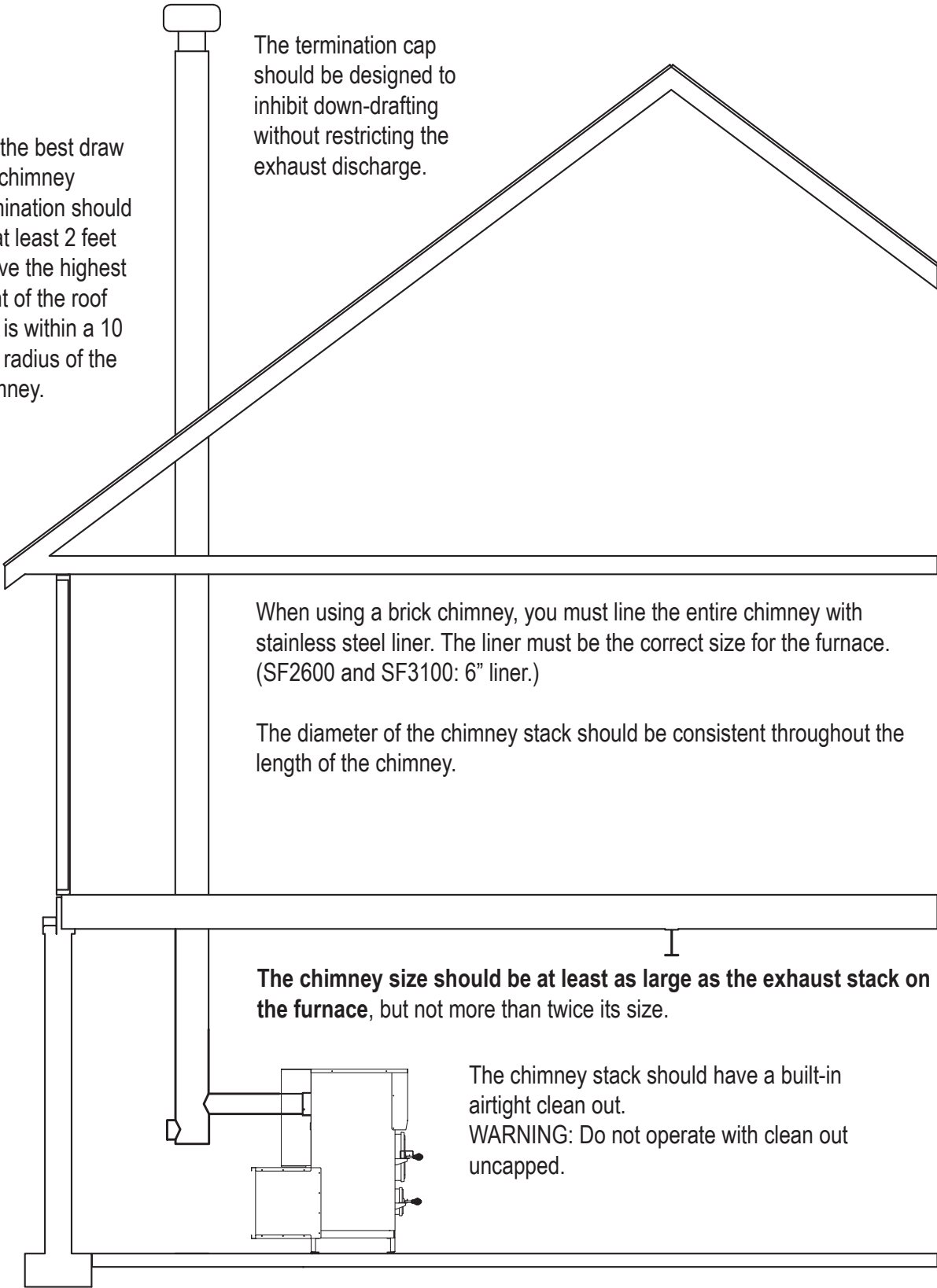

For the best draw the chimney termination should be at least 2 feet above the highest point of the roof that is within a 10 foot radius of the chimney.

The termination cap should be designed to inhibit down-drafting without restricting the exhaust discharge.

When using a brick chimney, you must line the entire chimney with stainless steel liner. The liner must be the correct size for the furnace. (SF2600 and SF3100: 6" liner.)

The diameter of the chimney stack should be consistent throughout the length of the chimney.

The chimney size should be at least as large as the exhaust stack on the furnace, but not more than twice its size.

The chimney stack should have a built-in airtight clean out.
WARNING: Do not operate with clean out uncapped.

WARNING- RISK OF FIRE:

- Do not operate with flue draft exceeding .08 water column inches (19.9 Pa).
- Do not operate with fuel loading or ash removal doors open.
- Do not store fuel or other combustible materials within marked installation clearances.
- Inspect and clean flues and chimney regularly.

DANGER: Risk of Fire and Explosion. Do not burn garbage, gasoline, naphtha, engine oil, or other flammable liquids/inappropriate materials.

WARNING:

- NEVER use galvanized pipe in your chimney connection, it produces poisonous gases when subjected to extreme temperatures.
- USE only lined masonry or manufactured Class "A" HT2100 All Fuel Chimney for your furnace.
- INSPECT chimney system periodically for structural integrity.
- CLEAN the chimney system regularly to prevent creosote accumulation.
- NEVER leave the ash pan in your furnace during operation.
- DO NOT CONNECT THIS UNIT TO A CHIMNEY FLUE SERVING ANOTHER APPLIANCE.

Duct Runs

Ductwork should be designed so the external static pressure on high speed does not exceed .02 water column inches while developing air velocities of 450 - 600 feet per minute at the registers. The heat outlet area should never be less than two 8-inch round pipes or 100 square inches. The furnace can be installed with a cold air return system, or the return air can be drawn from the basement. If the return air is drawn from the basement, you will have to install 3 "open and close" air register vents in the return air duct connected to your existing furnace; the air will take the path of least resistance without using ductwork to connect the two together. The return air system should be a minimum of 10% larger than the heat outlet to readily transfer the cold air back to the furnace. Avoid using 90° elbows in duct runs; 45° elbows provide better airflow and less resistance. CAUTION: The warm air supply outlet of the supplementary furnace should not be connected to the cold air return inlet of the central furnace, because a possibility exists for components to overheat and cause the central furnace to operate other than intended.

Canadian Requirements for Supplemental/Add-On Furnaces

- DO NOT USE DUCT ELBOWS HAVING AN INSIDE RADIUS OF LESS THAN 6 inches (150mm) ON OIL, ELECTRIC, OR GAS FURNACES.
- DO NOT CONNECT TO A DOWNFLOW FURNACE.
- DO NOT CONNECT DUCTWORK SO THAT A REVERSE FLOW IS POSSIBLE.
- OPERATE THE GAS/OIL/ELECTRIC/ FURNACE PERIODICALLY TO ENSURE THAT IT WILL OPERATE SATISFACTORILY WHEN NEEDED.
- CERTIFIED FOR INSTALLATION WITH APPROPRIATE DUCTWORK CONFIGURATIONS ONLY.
- DO NOT RELOCATE OR BYPASS ANY OF THE SAFETY CONTROLS IN THE ORIGINAL GAS/OIL/ELECTRIC FURNACE INSTALLATION.
- DO NOT CONNECT TO ANY GAS FURNACE THAT HAS NOT BEEN CERTIFIED INITIALLY AS COMPLYING WITH CAN/CGA-2.3.
- THE OPERATION OF THE GAS FURNACE MUST BE VERIFIED FOR ACCEPTABLE OPERATION BEFORE AND AFTER INSTALLATION OF THE ADD-ON APPLIANCE BY A GAS FITTER WHO IS RECOGNIZED BY THE REGULATORY AUTHORITY.
- DO NOT CONNECT TO ANY GAS FURNACE THAT IS NOT EQUIPPED WITH AN AIR-CIRCULATION BLOWER, OR TO A CHIMNEY OR VENT SERVICING A GAS FURNACE OR GAS APPLIANCE.

The add-on unit should only be installed on a furnace duct system and chimney that are in good operating condition.

If exhaust fans are installed in the storage area they should not create negative pressures in the room where the solid fuel-burning appliance is located.

On a belt-driven system, blower and motor pulleys may be changed but the electrical current flowing through the motor cannot exceed the nameplate rating. On a direct-drive system, the motor should not be changed, however, the speed of the motor may be increased. The blower cannot be changed. This equipment should be installed, acceptable to regulatory authority, by experienced licensed personnel.

Establish a routine for the storage of fuel, care of the appliance, and firing techniques.

Check daily for creosote build-up until experience shows how often cleaning is necessary.

Be aware that the hotter the fire, the less creosote is deposited, and that weekly cleaning may be necessary in mild weather, even though monthly cleaning may be enough in the coldest months. A small intense fire is preferable to a large smoldering fire to reduce the amount of creosote deposition.

The installation should comply with requirements of CAN/CSA-B365, and changes to the installation should comply with CSA-B139 (for oil-fired), C22.1 (for electric), or CAN/CGA-B149.1 or CAN/CGA-B149.2 (for gas-fired).

IMPORTANT: FOR TECHNICAL SUPPORT OR CUSTOMER SERVICE ISSUES, DO NOT RETURN TO THE STORE (THE STORE DOES NOT HAVE REPLACEMENT PARTS), CALL 1-800-875-4788.

BURN WOOD ONLY!

General Operation

Types of Wood to Use:

We advise using only dry, seasoned hardwoods in your Shelter Furnace rather than high resin woods such as pine. Firewood should be cut at least one full season prior to the time of its intended use, for optimum heat output. Firewood should be stacked to provide a free flow of air between the logs, thus allowing more rapid seasoning of the wood. If wood is stored outdoors, it should be completely covered year round to protect it from moisture and exposure to the elements.

FUEL RECOMMENDATIONS: (Log size by model)

- FC1500 – 20 inch maximum log length
- FC1700 – 26 inch maximum log length

Follow instructions included with the moisture meter that was supplied with this unit to make sure that you are using seasoned wood to achieve the cleanest burn and highest efficiency possible. When using the moisture meter, in addition to following the manufacturer's instructions, look for readings under 30% moisture content. Also seasoned wood will be noticeably lighter weight than green wood, generally has darker ends with cracks or splits visible.

Use extreme caution when opening the door during operation, temperatures can exceed 300°F. Wait at least 10 seconds after releasing the latch, and then proceed to the fully open position. Opening the door in this manner is designed to eliminate the possibility of gaseous ignition. Heat resistant gloves are recommended when opening the fuel door, emptying the ash pan.

CAUTION: HOT SURFACES. KEEP CHILDREN AWAY. DO NOT TOUCH DURING OPERATION.

This wood heater needs periodic inspection and repair for proper operation. If you observe excessive smoke, check to be sure you are burning properly seasoned cordwood and that there are no gaps in the gaskets on the door of the unit. When it becomes necessary to replace the gaskets:

- Order part number FCGSKT58 (fuel door) and/or FCGSKT12 (ash door)
- Remove old gasket
- Install new gasket in gasket channel of door
- Cut off excess gasket, ensure that there is no gap where the ends of the gasket material meet

CAUTION:

- INSPECT FLUE PIPES, JOINTS AND SEALS REGULARLY TO ENSURE THAT SMOKE AND FLUE GASES ARE NOT DRAWING INTO, AND ARE NOT BEING CIRCULATED BY THE AIR-CIRCULATION SYSTEM.
- CLEANING OF THE HEAT EXCHANGER, FLUE PIPE, CHIMNEY AND DRAFT INDUCER (IF USED), IS ESPECIALLY IMPORTANT AT THE END OF THE HEATING SEASON TO MINIMIZE CORROSION DURING THE SUMMER MONTHS CAUSED BY THE ACCUMULATED ASH.
- Never use chemicals or gasoline to start or maintain your fire.
- Do not burn oil, garbage, trash, plastic, or any fuel other than wood in your furnace. Doing so will void the warranty.
- **DO NOT leave the ash pan inside your furnace during operation.**

WARNING: – RISK OF FIRE

- DO NOT operate with flue draft exceeding .08 water column inches (19.9 Pa).
- DO NOT store fuel or other combustible materials within marked installation clearances.
- Inspect and clean flues and chimney regularly.
- DO NOT operate your furnace with the fuel or ash doors open.

WARNING: NEVER fuel your furnace with wet, unseasoned wood or wood that has been exposed to a recent rainfall. Burning wood with high moisture content will cause a rapid accumulation of hazardous creosote, which has been proven to be the most common cause of flue fires. NEVER burn plastics, any wood product containing glue, or wood treated with chemical preservatives in your furnace. The combustion of these substances may release harmful, toxic gases.

Do Not Burn:

- Garbage;
- Lawn clippings or yard waste;
- Materials containing rubber, including tires;
- Materials containing plastic;
- Waste petroleum products, paints or paint thinners, or asphalt products;
- Materials containing asbestos;
- Construction or demolition debris;
- Railroad ties or pressure-treated wood;
- Manure or animal remains;
- Salt water driftwood or other previously salt water saturated materials;
- Unseasoned wood; or
- Paper products, cardboard, plywood, or particleboard. The prohibition against burning these materials does not prohibit the use of fire starters made from paper, cardboard, saw dust, wax and similar substances for the purpose of starting a fire in a wood heater.

Burning prohibited materials may result in release of toxic fumes or render the heater ineffective and cause smoke.

DANGER: RISK OF FIRE OR EXPLOSION – do not burn garbage, gasoline, naphtha, engine oil, or other flammable liquids/inappropriate materials.

Supplemental Outside Combustion air may be necessary if:

- The solid-fuel-fired appliance does not draw steadily, smells, experiences smoke rollout, burns poorly, or back-drafts whether or not there is combustion present. Opening a window slightly on a calm day may alleviate these symptoms.
- The house is equipped with a well-sealed vapor barrier and tight fitting windows, and/or has any powered devices which exhaust house air.
- There is excessive condensation on windows in the winter.
- A ventilation system is installed in the house.

BURN WOOD ONLY!

First Fire:

Set the wall thermostat to 90°F. Make sure the switch for the draft blower is in the ON position.

Place several crumpled newspapers on the grate with some dry kindling layered on top of the papers, then ignite the newspaper. When the kindling is burning, add several small pieces of wood, allow wood to fully ignite. After about 20 minutes the fire should be established, allowing you to add more wood – do not overload which would smother the fire. Add more wood slowly, so the flames have time to engulf the fresh wood. Once the fire is burning and there is a glowing ember bed, set the wall thermostat to the desired home temperature.

Do not over-fire the furnace. Over-firing by overloading/over fueling the furnace causes the metal to superheat and expand, then cool rapidly, which causes cracking, therefore voiding the warranty. Over-firing or abuse can easily be determined upon inspection.

It will take about 40 minutes to establish a bed of hot embers. **Once you have achieved the hot ember bed, add larger pieces of firewood.** Finally adjust the wall thermostat. **Ash pan must remain out of furnace during operation.**

NOTE: Your new Shelter Furnace is capable of producing a very high BTU output. Do not fuel your furnace to capacity upon initial firing. It's recommended that you become thoroughly familiar with your Fire Chief Furnace before operating at full capacity.

The new steel and metal components of the furnace have a protective coating or paint on the surface which could produce an odor during the break in period. Adequate ventilation within the home and furnace room or area is recommended during the initial firing and break in period to accommodate this possibility. Your new Shelter Furnace is classified as having airtight construction. This type of design should enable you to experience an average burn time between 8 and 12 hours per full load of fuel (**dry, seasoned hardwood**). However, abnormally cold weather may reduce the burn time somewhat, but if your burn cycle is significantly less, for instance, 2 to 4 hours, you are over-firing your furnace. This type of occurrence is usually symptomatic of heat demands in excess of furnace capacity. Contact an authorized professional to determine if your Shelter Furnace has been improperly sized for your home. The heat output range, according to B415.1-10 testing, is 25,000 to 75,000 BTUs per hour.

Loading Wood:

When opening the fuel door during operation, always wait 10 seconds after releasing the first latch, then open the door the rest of the way. The dual latch system has been incorporated as a safety feature, designed to eliminate the possibility of gaseous ignition. Laboratory testing has determined that when incomplete combustion occurs the partially spent fuel sometimes concentrates large amounts of potentially hazardous gases within the fire chamber. If the door is opened suddenly under these conditions, the oxygen may combine with these gases and cause ignition referred to as "back flash." Use EXTREME CAUTION when opening the fuel door.

When reloading the furnace, spread embers evenly over the grate. Place smaller pieces of wood on the hot embers and layer larger pieces on top of them. **Finally, due to the wide variety of temperature ranges during the winter, you may experience periods when it is not necessary to fully load the fire chamber in order to maintain an overnight burn.** Your Shelter Furnace will operate at the highest efficiency by adding fuel in amounts needed to maintain comfortable temperatures in your home.

BURN WOOD ONLY!

Disposal of Ashes:

Heat resistant gloves are recommended. In order to remove ashes from your Shelter Furnace, open the ash door and slide the ash pan to the rear of the furnace. Remove the ash pan from the furnace and dump the ashes into a metal container with a tight fitting lid. The closed container of ashes should be placed on a non-combustible floor or on the ground, well away from all combustible materials, pending final disposal. If the ashes are disposed of by burial in soil or otherwise locally dispersed, they should be retained in the closed metal container until all cinders have thoroughly cooled.

The ash pan must be removed from your Shelter Furnace during operation. This precautionary measure is recommended

because if the ash pan is allowed to remain inside the furnace during operation, it will become dangerously hot to touch, block the flow of air under the grates and reduce the efficiency of the furnace.

Remove the ashes from your Shelter Furnace at least once a day, or as often as necessary to ensure the ashes do not accumulate to the height of the grates. If ash build-up occurs at grate level, it will cause premature failure of the grate system, voiding the warranty on the grates. Unacceptably high temperatures will result because the ashes have restricted the flow of cooling air beneath the grates. This flow of air was designed to not only cool the grates, but to also provide warmed air for better combustion. If the ash level is improperly maintained the firebox will be starved of combustion air, greatly reducing the efficiency and heat output of your Shelter Furnace.

CAUTION: HOT SURFACES. KEEP CHILDREN AWAY. DO NOT TOUCH DURING OPERATION.

IMPORTANT: FOR TECHNICAL SUPPORT OR CUSTOMER SERVICE ISSUES, DO NOT RETURN TO THE STORE (THE STORE DOES NOT HAVE REPLACEMENT PARTS), CALL 1-800-875-4788.

Draft Blower:

The draft blower plays an important role in the operation of your Shelter Furnace. When the wall thermostat calls for heat, the draft motor turns on and supplies fresh air into the firebox producing a hotter fire, which in turns provides more heat in the heat chamber. The heat is then sent through the duct system throughout your home. When the wall thermostat temperature is met, the draft blower shuts off until the thermostat calls for heat, beginning the cycle again. The draft blower has a slide cover located on the side of the motor that is factory preset, with an opening of approximately 3/8". The cover should be fully closed only when there is a power failure and electricity is lost. With the cover closed, no air is introduced into the firebox, then the fire dies, preventing the furnace from possible overheating and damage.

Important: Blower Speed Changes:

Your SF2600 or SF3100 furnace is equipped with a 3 speed high efficiency bearing shaft motor (started with a capacitor) that draws a maximum of 5 amps when set at high speed. The 3 speed switch on your electrical control center allows you to manually adjust speeds to your desired setting.

If you are unable to detect or hear the speed change when you move the switch selector to a different setting it doesn't mean the blower motor didn't change speeds.

Most blower motors that are manufactured today are sleeve shaft motors that don't have any bearings so the motor creates more variation in sound. Your motor has bearings so it runs very smoothly and quietly.

The furnace needs to be connected to ductwork to have significant resistance (static pressure) against the blower so it will operate at full power. If you are running the blower without a fire in the furnace, the speeds will be different than when you have a fire burning. Hot air flows through the ductwork with less resistance than cold air.

Creosote Formation and Need for Removal:

When wood is burned slowly, it produces compounds in exhaust smoke which combine with expelled moisture to form creosote. The creosote vapors condense in the relatively cooled chimney flue of a slow burning fire. As a result, creosote residue accumulates on the flue lining. When ignited, this creosote makes an extremely dangerous fire in the chimney. The chimney connector and the chimney should be inspected at least twice monthly during the heating season to determine if a creosote build-up has occurred. If creosote has accumulated it should be removed to reduce risk of a chimney fire.

Creosote Prevention:

To help reduce the formation of creosote within the flue, ALWAYS BURN DRY, SEASONED WOOD. Dry wood burns hotter, allowing flue gases to maintain temperatures above 212°F which should reduce the quantity of creosote in the chimney. If the flue gas temperature falls below 212°F, condensation occurs causing creosote formation and accumulation within the chimney.

As an added precaution, periodic chimney inspections are recommended during the heating season to determine if creosote formation has occurred. For safety and efficiency, it is recommended that the chimney system be inspected and cleaned prior to each heating season.

Chimney Fire Warning:

In the event of a chimney fire, take the following actions immediately:

- Activate and toss a Chimfex™ Dry Chemical Chimney Fire Extinguisher into the firebox.
- Close the ash door, fuel door and slide cover on the draft motor.
- Alert entire household and prepare to evacuate if necessary.
- Call your local fire department.

Power Failure:

In case of power failure, to prevent your Shelter Furnace from over-heating and causing damage to the electrical components, do NOT add more fuel to the firebox.

There is no warranty on electrical components damaged due to power failure.

NOTE: OVER-FIRING OR DELIBERATE ABUSE CAN EASILY BE DETERMINED UPON INSPECTION AND WILL VOID THE WARRANTY.

This wood heater has a manufacturer-set minimum low burn rate that must not be altered. It is against federal regulations to alter this setting or otherwise operate this wood heater in a manner inconsistent with operating instructions in this manual.

Always keep your wood covered year round. Dry wood will produce a higher BTU output and a longer burn time. Refer to the nameplate on furnace for additional information.

WARNING: RISK OF FIRE

- Do not operate with the flue draft exceeding .08 water column inches (19.9 Pa).
- Do not operate with fuel loading or ash removal doors open.
- Do not store fuel or other combustible material within marked installation clearances.
- Inspect and clean flues and chimney regularly.
- Door seals should be checked annually to make sure that a good seal will ensure complete combustion and high efficiency.

THIS IS A WOOD BURNING FURNACE ONLY AND SHOULD NOT BE ALTERED IN ANY WAY.

Furnace Diagram

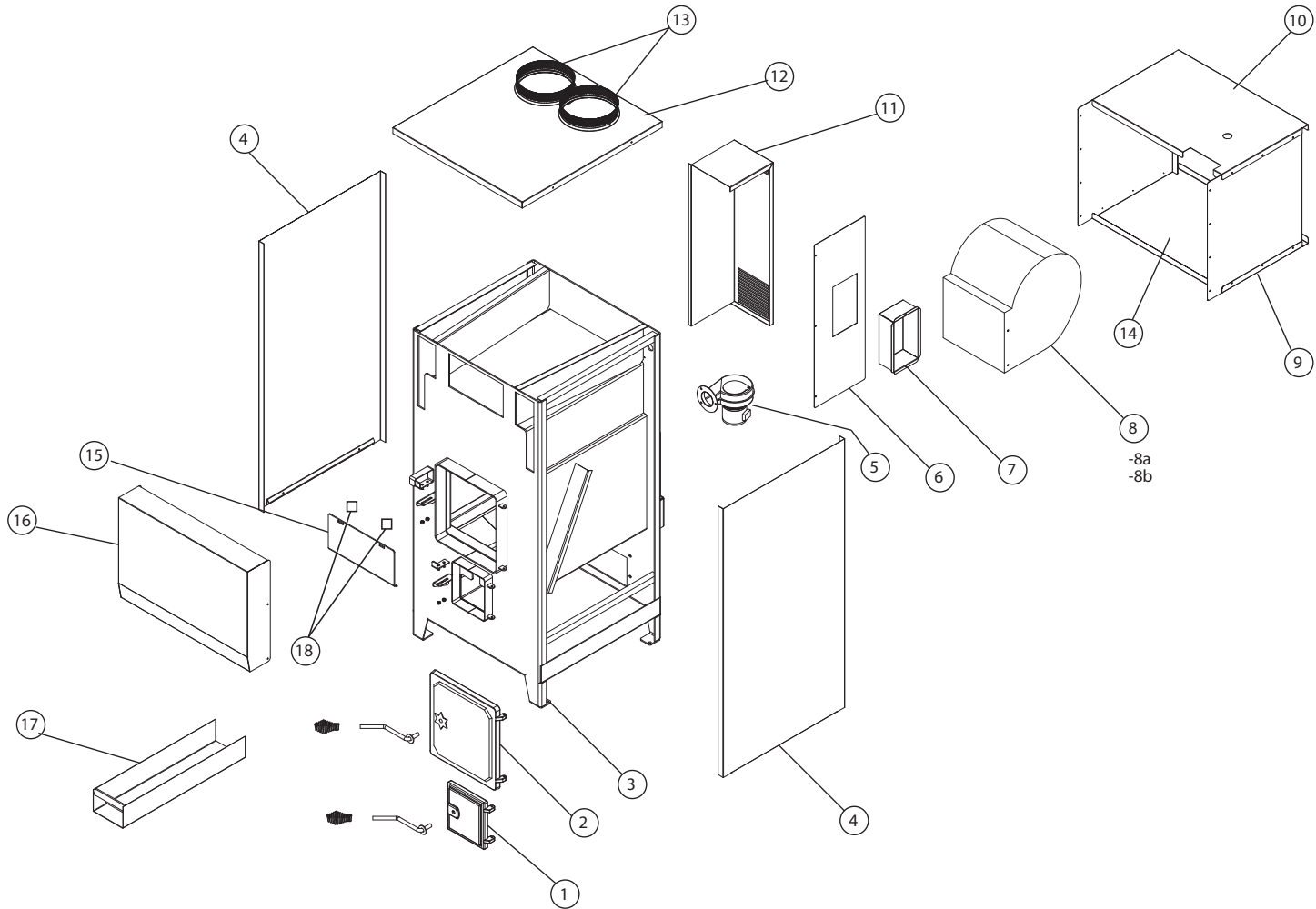

PARTS LIST				
ITEM	QTY	PART DESCRIPTION	SF2600 PART NUMBER	SF3100 PART NUMBER
1	1	ASH DOOR ASSEMBLY	SFE-ADA	SFE-ADA
2	1	FUEL DOOR ASSEMBLY	SFE-FDA	SFE-FDA
3	1	FURNACE SHELL	FC15SHELL	FC17SHELL
4	2	SIDE PANEL ASSEMBLY	SFE-26SP	SFE-31SP
5	1	DRAFT BLOWER MOTOR	FCDB	FCDB
6	1	ELECTRICAL ENCLOSURE- SIDE	WAF-002	WAF-002
7	1	ELECTRICAL CONTROL ASSEMBLY INDOOR	WAF-IECA	WAF-IECA
8	1	BLOWER ASSEMBLY	FC3SPMOTOR	FC3SPMOTOR
8a	(1)	BLOWER MOTOR	FCDD037P	FCDD037P
8b	(1)	BLOWER HOUSING	FCBH	FCBH
9	2	FILTER BOX SIDE	WAF-FBS	WAF-FBS
10	1	FILTER BOX TOP	WAF-FBT	WAF-FBT
11	1	ELECTRICAL ENCLOSURE- COVER	WAF-003	WAF-003
12	1	TOP PANEL INSULATED	SFE-26TP	SFE-31TP
13	2	STARTER COLLAR	SNGCLR8	SNGCLR8
14	1	FILTER BOX BOTTOM	WAF-FBB	WAF-FBB
15	1	SMOKE CURTAIN	WAF-SC	WAF-SC
16	1	FRONT WARM AIR PANEL	SFE-FAP	SFE-FAP
17	1	ASH PAN	WAF-15AP	WAF-17AP
18	2	CURTAIN CLIP	WAF-CC	WAF-CC

(1) 1 each of Items 8a & 8b are components making up a portion of item 8 and available individually

Grate System Diagram - SF2600

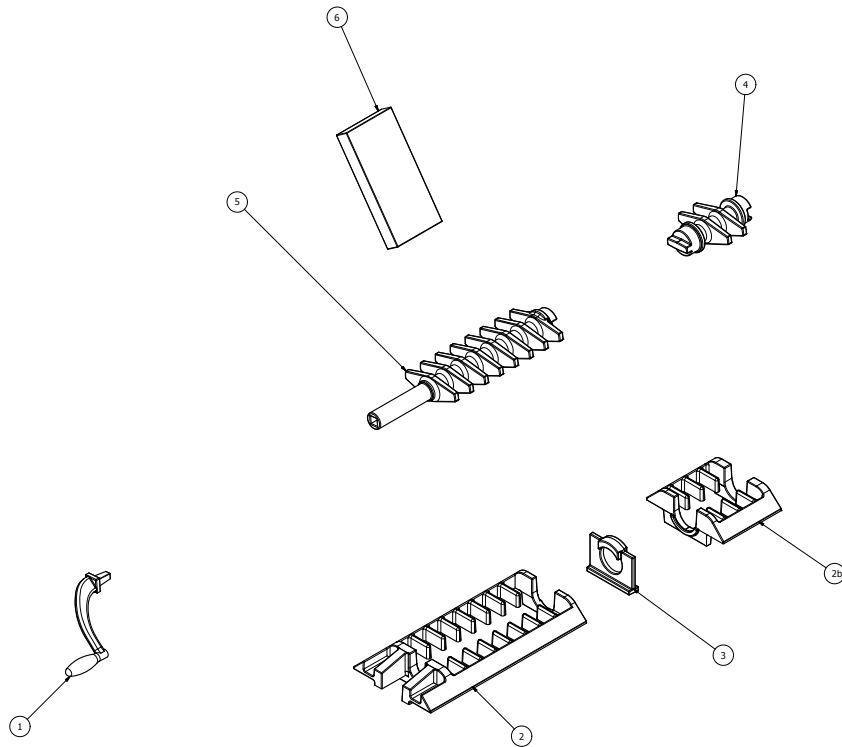

SF2600 PARTS LIST		
ITEM	QTY	PART DESCRIPTION
1	1	FC00 ROLLER GRATE HANDLE
2	1	ROLLER GRATE BASE
3	1	ROLLER GRATE SUPPORT
2b	1	ROLLER GRATE EXTENSION BASE - SHORT
4	1	FC000 ROLLER GRATE EXTENSION - SHORT
5	1	FC000 ROLLER GRATE
6	6	FIRE BRICK

Grate System Diagram - SF3100

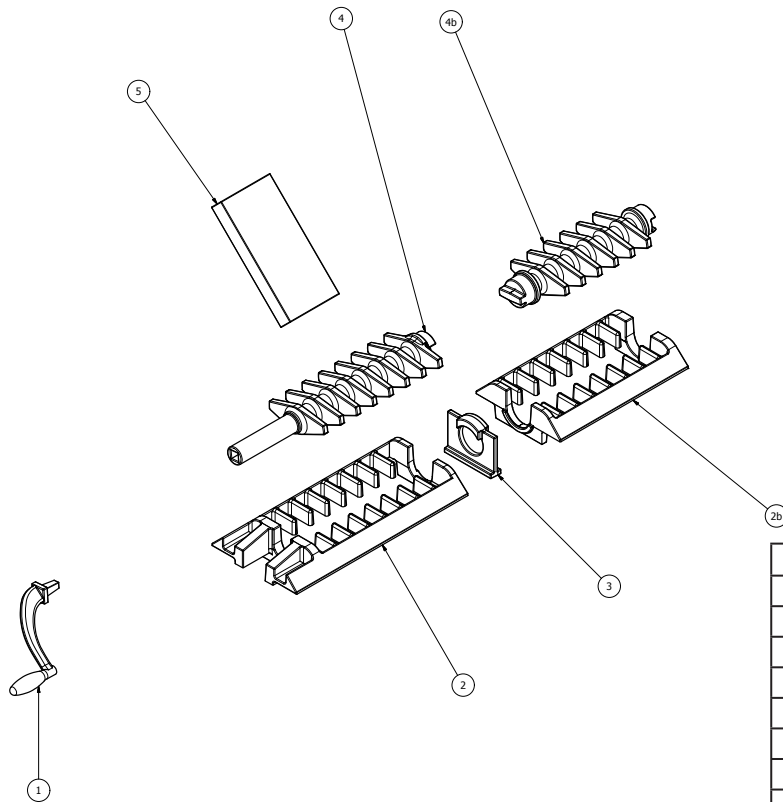

SF3100 PARTS LIST		
ITEM	QTY	PART DESCRIPTION
1	1	FC000 ROLLER GRATE HANDLE
2	1	ROLLER GRATE BASE
2b	1	ROLLER GRATE EXTENSION BASE
3	1	ROLLER GRATE SUPPORT
4	1	FC000 ROLLER GRATE
4b	1	FC000 ROLLER GRATE EXTENSION
5	6	FIRE BRICK

Blower Motor Assembly Diagram

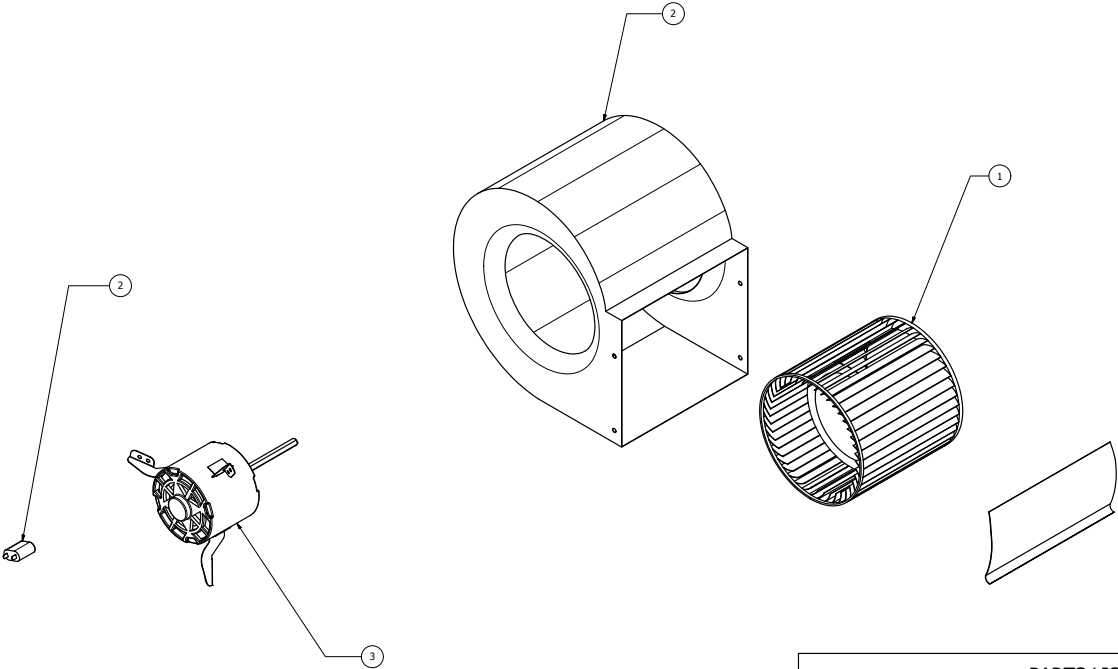

PARTS LIST		
ITEM	QTY	DESCRIPTION
1	1	BLOWER WHEEL
2	1	BLOWER HOUSING
3	1	MOTOR CAPACITOR
4	1	BLOWER MOTOR

Wiring Diagram

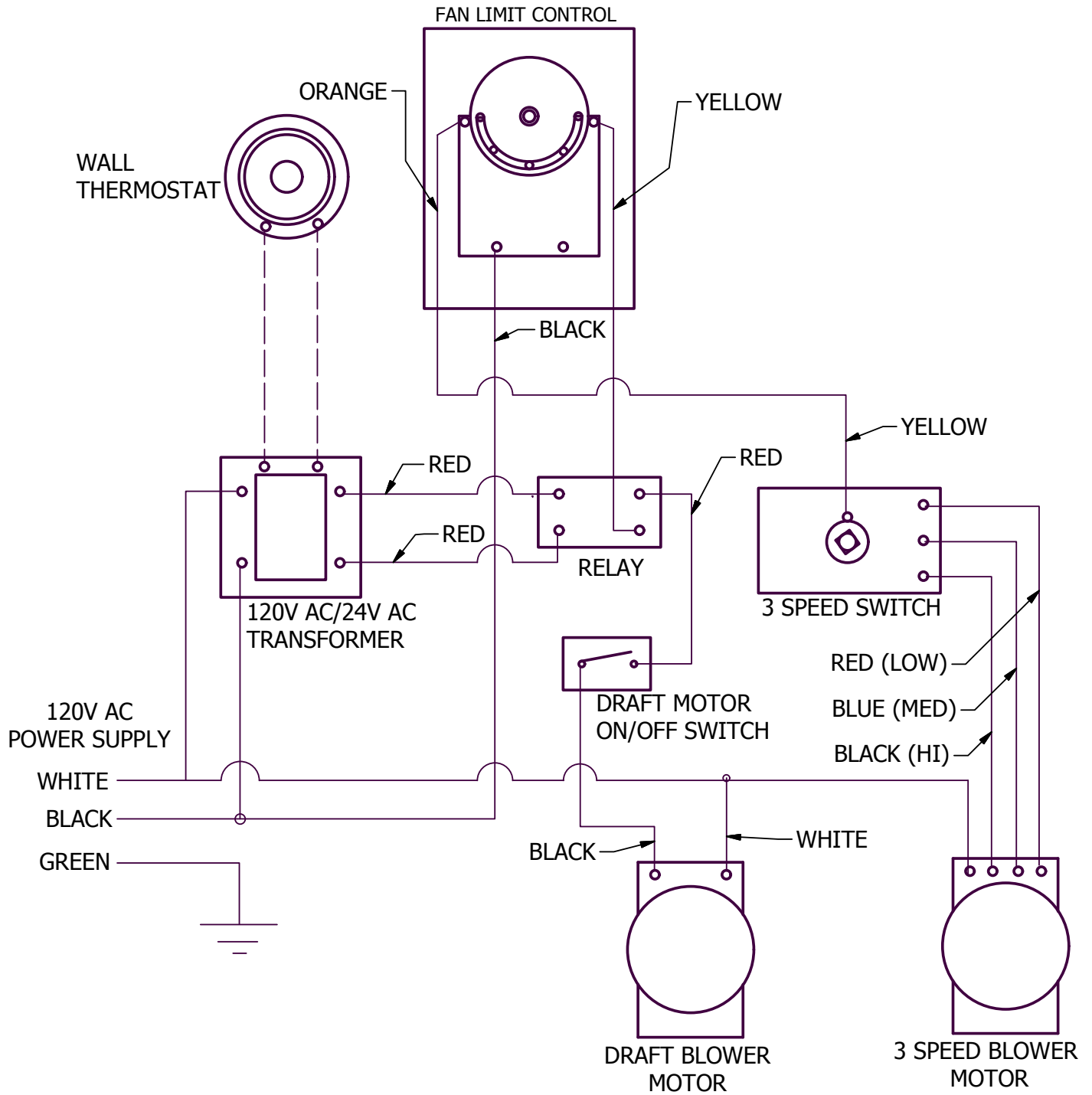

Troubleshooting

1. Problem: Circulation blower runs constantly. NOTE: Make sure the white button on fan limit control is pulled out and in the “auto” position.

Possible Causes:

Remedies:

- | | |
|---|--|
| <ul style="list-style-type: none">• “Off” setting on fan limit control is low. | <ul style="list-style-type: none">• Remove cover on fan limit control and check for the proper setting. The point indicators should be set at 100° “Off” and 150° “On.” Do NOT attempt to adjust the fan limit by manually adjusting the temperature indicators on the dial. |
| <ul style="list-style-type: none">• White button on fan limit control is pushed in. | <ul style="list-style-type: none">• Pull white button out and the blower should stop. |
| <ul style="list-style-type: none">• Defective fan limit. | <ul style="list-style-type: none">• Check by moving “ON” and “OFF” point indicator to a temperature position where blower should turn off. If the blower continues to run, replace the fan limit. |
| <ul style="list-style-type: none">• Improper wiring. | <ul style="list-style-type: none">• Review wiring diagram. If unit is wired correctly, seek professional assistance. |
| <ul style="list-style-type: none">• Backdraft damper is in the “closed” position. | <ul style="list-style-type: none">• Open backdraft damper. |

2. Problem: Circulation blower vibrates during operation.

Possible Causes:

Remedies:

- | | |
|--|--|
| <ul style="list-style-type: none">• Screw on squirrel cage is not tight. | <ul style="list-style-type: none">• Check squirrel cage alignment and position so that it does not drag on the housing during rotation, then tighten the screw sufficiently to fasten the squirrel cage securely to the shaft. |
| <ul style="list-style-type: none">• Balance weights on squirrel cage have become dislocated. | <ul style="list-style-type: none">• You may attempt to adjust the weights yourself to obtain an acceptable balance. If you are unsuccessful, contact your supplier. |
| <ul style="list-style-type: none">• Defective main bearings. | <ul style="list-style-type: none">• Return the blower to your supplier for replacement. |

3. Problem: Flames discharging from fuel door during reloading.

Possible Causes:

Remedies:

- | | |
|--|---|
| <ul style="list-style-type: none">• Opening the door has provided additional oxygen which has ignited the accumulated gases from partially spent fuel. | <ul style="list-style-type: none">• Always open the door cautiously and allow the safety latch system to perform its designed function, containing gases within the fire chamber. |
| <ul style="list-style-type: none">• Cast iron damper in the “CLOSED” position. | <ul style="list-style-type: none">• Open damper. |
| <ul style="list-style-type: none">• Insufficient natural draft or an obstruction in the flue system. | <ul style="list-style-type: none">• See #6 and #9. |
| <ul style="list-style-type: none">• Fire chamber filled to capacity with unburned fuel. | <ul style="list-style-type: none">• Do not attempt to overload the furnace. |

4. Problem: Draft blower will not run. NOTE: Verify that the wall thermostat is in the “HEAT” position, and make sure batteries are installed.

Possible Causes:

- Defective rocker switch on control center.
- Defective wall thermostat.
- Wall thermostat is in the wrong position.
- Defective relay in transformer.
- Defective draft motor.
- Improper wiring.

Remedies:

- Replace rocker switch.
- This can be checked by turning the thermostat to a temperature setting that is higher than the temperature in your home. If the draft blower does not operate, the thermostat may be defective. Replace if necessary.
- Move switch on wall thermostat to the “HEAT” position.
- Replace relay.
- Replace draft motor.
- Review wiring diagram. If unit is wired correctly, seek professional assistance.

5. Problem: Excessive dirt accumulation surrounding air registers in the home.

Possible Causes:

- Furnace is not connected to return air duct and is drawing dirt from furnace room floor and discharging it throughout home.
- Filter box not installed, or no filter in filter box.

Remedies:

- Connect to return air duct system.
- Install filter box on furnace. Install filter in filter box.

6. Problem: Smoke from the fire chamber is puffing back through the forced draft motor.

Possible Causes:

- Furnace is not connected to return air and is drawing smoke fumes from the flue.
- Excessively long run of stove pipe from furnace to flue.
- Too many elbows.
- Insufficient flue size.

Remedies:

- Connect to return air duct system. Or room may be too airtight, refer to “Location and Installation” section on page 3.
- Relocate the furnace so the horizontal run does not exceed 5 feet and has a 2 inch rise per foot.
- The run should not contain more than 2 elbows.
- Replace with a larger flue providing a minimum of 50 square inches but not more than 100 square inches of draft area. If the flue is within these specifications, check the draft with a draft gage (manometer). Your flue should provide a minimum of .04 water column inches and a maximum of .08 water column inches.

7. Problem: Draft blower runs constantly.

Possible Causes:

- Defective wall thermostat.
- Defective relay in transformer.
- Home is not being supplied with a sufficient amount of heat to satisfy the wall thermostat.

Remedies:

- This can be checked by turning the thermostat to a lower setting than the temperature in your home. If the draft blower continues to run, the thermostat may be defective. Replace if necessary.
- Replace transformer and relay.
- Have a professional determine the proper size furnace and insulation factor of your home.

8. Problem: Rapid accumulation of creosote in furnace and flue.

Possible Causes:

- **Use of high resin wood, such as pine.**
- Under-firing the furnace has caused low flue gas temperature.
- Insufficient chimney draft.
- Using uninsulated stove pipe for the chimney, especially if the construction is on the exterior of the home.
- Improper connection in stove pipe causing air leakage or a structural defect in the chimney itself.
- Fire box not receiving adequate amount of oxygen.
- Use of an unlined masonry chimney with a large clay tile opening.

Remedies:

- **Completely avoid using if at all possible. If hardwoods are not available, fuel the furnace with smaller loads. This will cause the thermostat to call for more heat more often, which will initiate the running of the draft blower. Consequently, the fires will be hotter, thereby reducing the accumulation of creosote.**
- Install flue gas thermometer and maintain stack temperatures between 300° and 400° F.
- See #9.
- **DANGER: Never use uninsulated stove pipe as chimney. It must not be used on the inside of your home due to high stack temperatures, which create an extreme fire hazard. Uninsulated pipe cannot be used as an outside flue because it causes rapid cooling of the stack gases, which causes them to condense as creosote on the inside of the flue.**
- Inspect entire flue run, from the exhaust stack of the furnace to the termination cap. Repair as necessary.
- Furnace room may be too airtight to supply sufficient amount of oxygen for combustion. Install an aperture to the outside consisting of a minimum of 12 square inches or 4 inches round.
- Install stainless steel liner in masonry chimney to reduce creosote formation and improve draw. Use appropriate size stainless liner for the furnace.

9. Problem: Down draft on chimney caused by one or more of the following.

Possible Causes:

- Cast iron damper in “CLOSED” position.
- Flue has a cold spot which inhibits exhaust discharge from rising properly.
- There is an obstruction outside chimney, such as a tree.
- Flue is located too close to the peak of the roof or does not rise above it to provide the proper draft.
- Backdraft damper is in the “closed” position.

Remedies:

- Open damper.
- This problem may occur in factory built flues because the insulation has settled or a seam has ruptured. In masonry flues, mortar loss may be causing seepage of cooler outside air into the stack. Check entire flue for structural integrity and leakage. Correct or repair as needed, or replace or re-line the chimney.
- Remove obstruction.
- Increase chimney height.
- Open backdraft damper.

10. Problem: Odor detected in home during initial firing.

Possible Causes:

- There is an oily film that remains on the steel after the manufacturing process. Firing the furnace has raised the temperature of the fire box to a level that is sufficient to vaporize the residue.

Remedies:

- The odor should disappear after a few hours of usage.

11. Problem: Excessive smoke discharge from fuel door during reloading.

Possible Causes:

- Cast iron damper in the “CLOSED” position.
- Excessively long stove pipe run from furnace flue.
- Too many elbows.
- Insufficient draft.
- Excessive smoke accumulation.

Remedies:

- Open damper.
- See #6.
- See #6.
- See #6.
- See #9.

12. Problem: Home does not achieve comfortable temperature.

Possible Causes:

- Improper ductwork connection to existing furnace.
- Improperly sized ducting.
- Excessive dirt accumulation in air filter.
- Combustion chamber not receiving an adequate amount of oxygen.
- Furnace size is inadequate for your home.
- Slide cover on draft blower is "CLOSED."
- **Fueling furnace with wet or unseasoned wood.**
- Ash pan is in the furnace, resulting in an insufficient air flow for combustion.

Remedies:

- Refer to information in the manual relating to the proper installation procedures or contact your local heating and cooling contractor.
- Refer to information in the manual relating to the proper ducting procedures or consult your local heating and cooling contractor.
- Check and replace filter. Proper filter size is 20" by 25" by 1."
- Furnace room may be too airtight. Install an aperture to the outside consisting of a minimum of 12 square inches or 4 inches round.
- Consult a professional to determine correct sizing.
- Open slide cover.
- **Completely avoid using if at all possible. If circumstances necessitate the use of wet or unseasoned wood, then fuel the furnace with smaller loads. This will cause the thermostat to call for heat more often, which will initiate the running of the draft blower. Consequently, the fires will be hotter, thereby reducing the accumulation of creosote.**
- Remove ash pan and store under furnace during operation.

13. Problem: Bugs found in wood.

Possible Causes:

- Wood has rotted or has been laying around for an extended period of time.

Remedies:

- Inspect the wood for obvious signs of insect infestation such as burrows or holes, avoid using if possible. Do not store wood indoors.

14. Problem: Circulation blower will not turn on.

Possible Causes:

- Defective fan limit control.
- Defective capacitor.
- Defective blower.
- Improper wiring.

Remedies:

- Check by pushing the white button on the fan limit control to the manual position where the blower should turn on. If the blower fails to run, replace the fan limit.
- Replace capacitor.
- Contact your supplier for replacement.
- Review wiring diagram. If wired correctly, seek professional assistance.

15. Problem: Cannot hear or detect changes in blower motor speed.

Possible Causes:

- Your motor has bearings so it runs smoothly and quietly.

Remedies:

- Refer to information in the manual on page 13 to understand the operation of the blower motor.

Warranty Information

CERTIFICATE OF LIMITED WARRANTY:

EXTENT OF COVERAGE: This warranty covers any Shelter Furnace SF2600 and SF3100 sold in the United States and Canada. This warranty applies only if the Shelter Furnace is installed, maintained, and operated in accordance with the instructions in the owner's manual and local codes. This warranty applies to the original purchaser/owner of the Shelter Furnace and is not transferable. Replacement or repair parts are warranted for the remaining period of the original warranty.

All warranty claims must include:

- Date of purchase
- Model and serial number
- Proof of purchase (dated invoice, bill of sale, cancelled check, or payment record)
- The name / address of the store from which you purchased the furnace

Shelter Furnace warranties the cast iron grates and firebox to be free of defects in material and workmanship for five years to the original purchaser. Intentional misuse or abuse causing burn through of the cast iron components voids all warranties. Over firing the furnace will cause the front face to crack and is not covered by the warranty. Furthermore, some cosmetic deterioration can be expected as the result of normal operation, therefore the physical appearance is not guaranteed to remain unchanged. The manufacturer warrants all electrical components for 1 year and the draft blower and distribution motor for 2 years. Please be advised that the firebrick and door gaskets are excluded from this warranty.

In order to exercise the aforementioned warranty, a certified professional must determine the appliance/part to be defective. He or she must submit a written statement to Shelter Furnace detailing an assessment of the problem. This assessment **MUST** be accompanied by substantiating proof of purchase (dated invoice, bill of sale, canceled check, or payment record), model and serial number. Shelter Furnace will then authorize repair or replacement as appropriate to the submitted claim. Shelter Furnace will not honor expenses incurred from any action that was not expressly consented to in writing. The owner is hereby notified that he or she will be obligated to assume liability for removal, re installation, shipping, and labor costs involved in servicing/repairing or replacing the part or unit. The merchandise in question must be shipped via **PREPAID FREIGHT** to Shelter Furnace. Shelter Furnace will return the repaired or replacement part to the purchaser on a **FREIGHT COLLECT** basis.

This warranty will be rendered null and void if this part/unit exhibits symptoms of obvious over-firing, deliberate abuse or negligence, improper installation, or is used for commercial purposes.

Finally, Shelter Furnace will not be responsible for any claim not stated in our warranty nor does any implied warranty extend beyond the limits stated above.

Please contact Shelter Furnace with all pertinent information including daytime phone number and detailed description of the type of problem you are having. Shelter Furnace technical service personnel will contact you as soon as possible. Call 1-800-875-4788 or mail information to: Shelter Furnace, 10950 Linpage Place, Saint Louis, MO 63132.

