

# GEARWRENCH

*FORGE AHEAD*

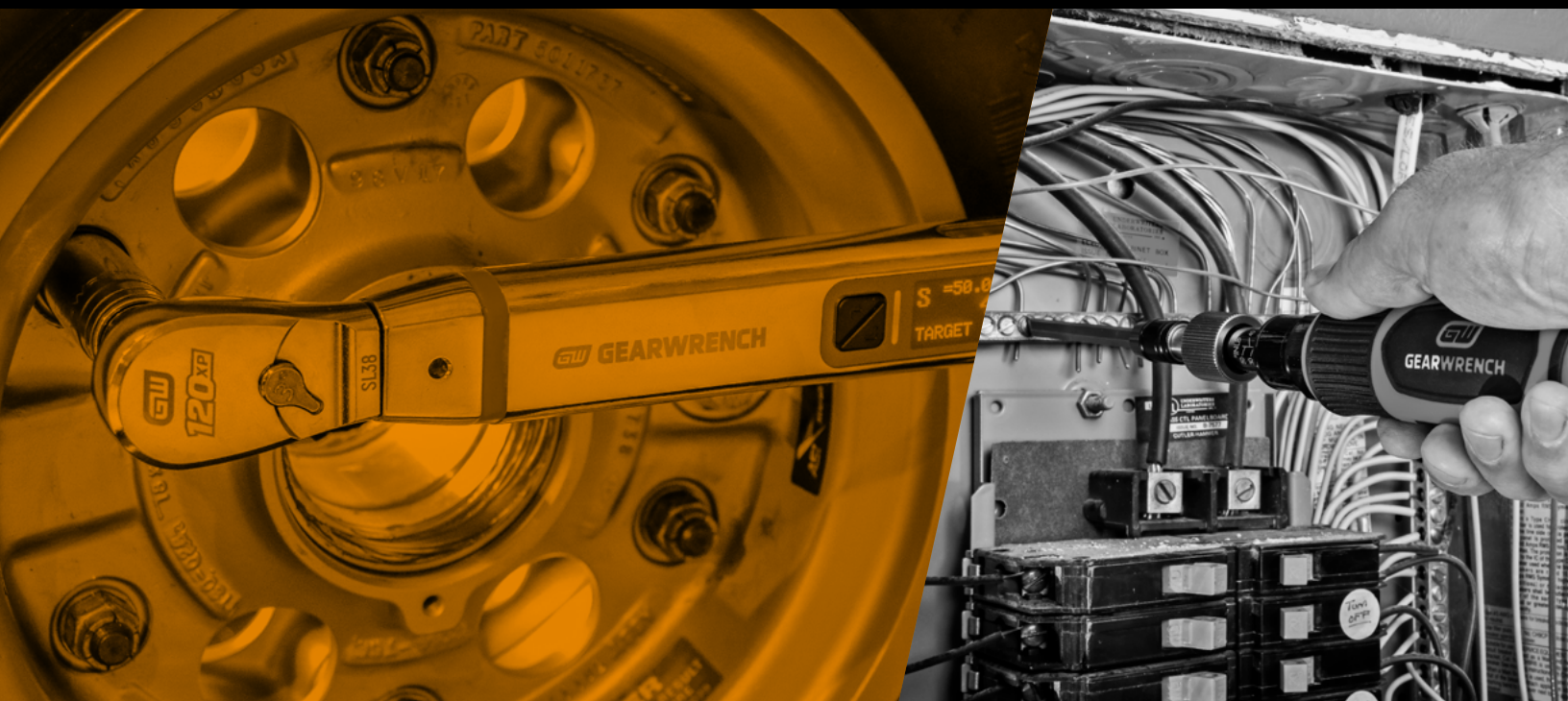

## Torque Products for Industry



# Torque Products for Industry

Regardless of industry, when there is a requirement for the precise application of torque, GEARWRENCH has the right tool for the job. From structural steel framing to concrete anchor bolts to electrical clamps, GEARWRENCH torque wrenches are up to the task, meeting or exceeding ASME requirements for a wide range of fastener applications.



## AUTOMOTIVE

- 120XP Micrometer Torque Wrenches
- 120XP Electronic with Angle Torque Wrenches

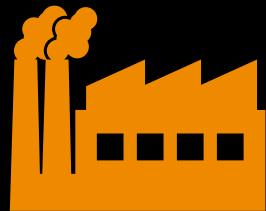

## PLANT MAINTENANCE

- "E-Spec" Torque Wrenches
- 3/4" and 1" Drive Mechanical and Electronic Torque Wrenches
- Torque Testers
- Service and Calibration Program

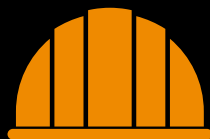

## CONSTRUCTION

- 3/4" and 1" Drive Mechanical and Electronic Torque Wrenches
- Cross Reference to Concrete Anchor Applications



## ELECTRICAL

- Torque Screwdrivers
- 20pc. Electrical Service Kit
- Cross Reference to Terminal Connections

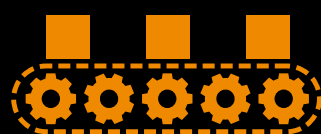

## ASSEMBLY

- "E-Spec" Torque Wrenches
- Preset Torque Wrenches
- Interchangeable Head Torque Wrenches
- Torque Screwdrivers



# GEARWRENCH

GEARWRENCH has been an innovator in the manufacture of torque wrenches since early in its history. Our promise is to meet the demanding needs of professional users by supplying high quality products and expert support. With design innovations on everything from micrometer "click" wrenches to full featured electronic torque wrenches, we continue to provide an expanding selection of high performance torque products. This guide covers the full line of GEARWRENCH torque wrenches and related products, including recent additions of proven designs in new product categories.

## CONTENTS

120XP Micrometer Torque Wrenches.....	4
Micrometer Torque Wrenches.....	4
Beam Torque Wrenches.....	5
120XP Electronic Torque Wrenches.....	6
Standard Electronic Torque Wrenches.....	6
120XP E-Spec Connected Wrenches.....	7
Interchangeable Torque Wrenches.....	10
Preset Torque Wrenches.....	11
Torque Screwdrivers.....	15
Torque Multipliers.....	16
Torque Testers.....	16
Replacement Parts.....	17
Torque Conversion Charts.....	18
Warranty and Service Program.....	20

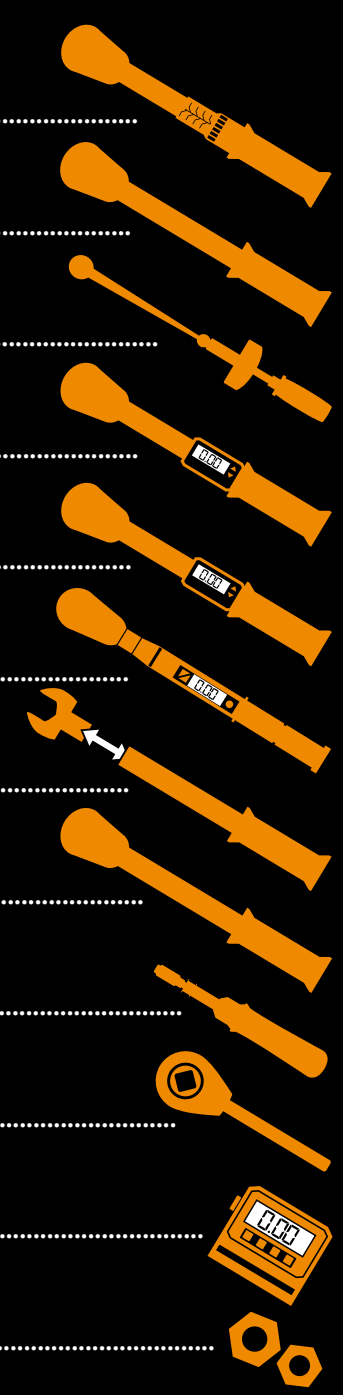

# 120<sup>XP</sup> Micrometer Torque Wrenches

- Accurate in clockwise direction +/- 3% from 20% to 100% of full scale
- Meets or exceeds ASME B107.300
- Enclosed head design for extreme resistance to dirt infiltration
- Teardrop low profile head and flush mounted on/off switch allow better access in tight spaces
- Pull back locking collar

- Injection molded cases with removable lids for convenient storage

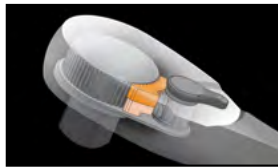

- 120 positions, 3 degree ratcheting arc

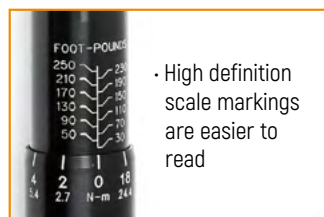

- High definition scale markings are easier to read

- Dual Scales, Metric and SAE

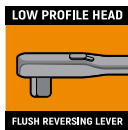
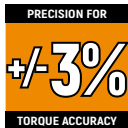

85181  
1/2" Drive

- Pull back locking collar
- Knurled aluminum grip
- Midpoint marked for accuracy

Cat. No.	Certified Model No.	Drive Size	Head Style	Primary Scale Range	Primary Scale Increments	Alt. Scale Range	Alt. Scale Increments	Tooth Count	Head Thickness (in)	Head Width (in)	Overall Length (in)	Product Weight
85171	85171CERT	1/4"	Standard	30-200 in/lbs	1 in/lb	4 - 23 Nm	0.11 Nm	60T/120 Pos.	0.39	1	11	0.85
85176	85176CERT	3/8"	Standard	10-100 ft/lbs	1 ft/lb	20 - 142 Nm	1.4 Nm	60T/120 Pos.	0.55	1.25	18.35	2.55
85181	85181CERT	1/2"	Standard	30-250 ft/lbs	2 ft/lb	54 - 353 Nm	2.7 Nm	60T/120 Pos.	0.75	1.75	24.875	3.7
85174	85174CERT	3/8"	Standard	30 - 250 in/lbs	1 in/lb	4 - 23 Nm	0.11 Nm	60T/120 Pos.	0.55	1.25	18.25	2.55
85180	85180CERT	1/2"	Standard	20 - 150 ft/lbs	1 ft/lb	27 - 203 Nm	1.4 Nm	60T/120 Pos.	0.75	1.75	24.88	3.7
85188	85188CERT	3/8"	Flex	5-75 ft/lbs	1 ft/lb	7 - 136 Nm	1.4 Nm	60T/120 Pos.	0.55	1.25	18.5	2.6
85189	85189CERT	1/2"	Flex	30-250 ft/lbs	2 ft/lb	54 - 353 Nm	2.7 Nm	60T/120 Pos.	0.75	1.75	26	4

# Micrometer Torque Wrenches

- Meets or exceeds ASME B107.300

- Non-slip metal knurling handle grip for superior hold

- Accurate in clockwise direction +/- 3% from 20% to 100% of full scale

- Thin profile, sealed tear-drop head design for access and durability

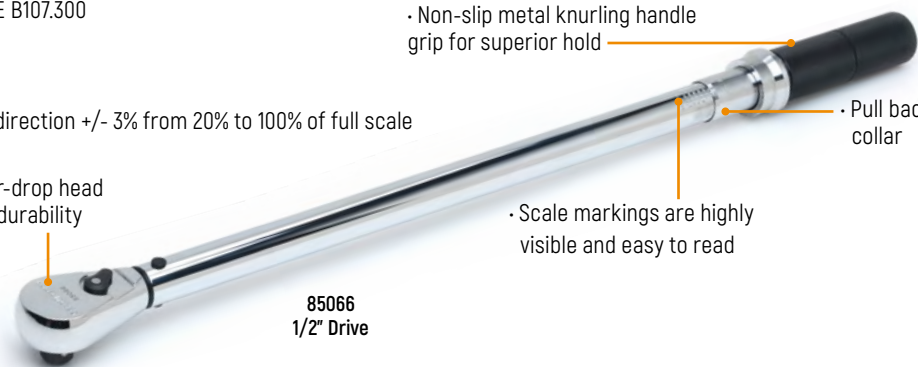

85066  
1/2" Drive

- Scale markings are highly visible and easy to read

- Pull back locking collar

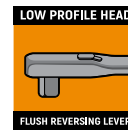
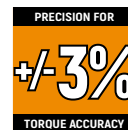

Cat. No.	Certified Model No.	Drive Size	Head Style	Primary Scale Range	Primary Scale Increments	Alt. Scale Range	Alt. Scale Increments	Tooth Count	Head Thickness (in)	Head Width (in)	Overall Length (in)	Product Weight
85060	85060CERT	1/4"	Standard	30-200 in/lbs	1 in/lb	4 - 23 Nm	0.1	22	0.54	11	10.5	0.8
85061	85061CERT	3/8"	Standard	20-250 in/lbs	1 in/lb	5 - 29 Nm	0.2	30	0.72	14	14	1.95
85062	85062CERT	3/8"	Standard	10-100 ft/lbs	1 ft/lb	20 - 142 Nm	1	30	0.72	14	18	2.5
85063	85063CERT	1/2"	Standard	20-150 ft/lbs	1 ft/lb	34 - 210 Nm	1	32	0.81	1.75	21.9	3.1
85066	85066CERT	1/2"	Standard	30-250 ft/lbs	2 ft/lb	54 - 353 Nm	3	32	0.81	1.75	24.3	3.5
85086	85086CERT	3/8"	Flex	5-75 ft/lbs	5 ft/lb	10 - 105 Nm	1	30	0.72	1.4	17.7	2.42
85087	85087CERT	1/2"	Flex	30-250 ft/lbs	2 ft/lb	54 - 353 Nm	3	36	0.93	1.75	25.25	3.82

# 3/4" & 1" Micrometer Torque Wrenches

- Meets or exceeds ASME B107.300

- Accurate in clockwise direction +/- 3% from 20% to 100% of full scale

- Easy lock and adjustment design

- Scale markings are highly visible and easy to read

- Knurled steel for durability and grip

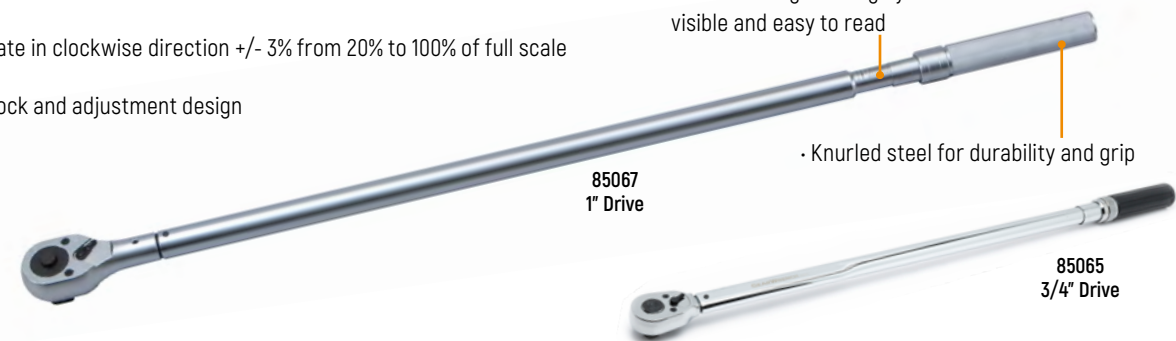

85067  
1" Drive

85065  
3/4" Drive

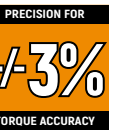

Cat. No.	Certified Model No.	Drive Size	Head Style	Primary Scale Range	Primary Scale Increments	Alt. Scale Range	Alt. Scale Increments	Tooth Count	Head Thickness (in)	Head Width (in)	Overall Length (in)	Product Weight
85065	85065CERT	3/4"	Standard	100-600 ft/lbs	2.5 ft/lb	153 - 831 Nm	4	36	1.14	2.62	42.4	15.8
85067		1"	Standard	150-750 ft/lbs	5 ft/lb	237-983	5	24	1.34	2.76	48.81	14.08
85068		1"	Standard	200-1000 ft/lbs	5 ft/lb	305-1322	5	24	1.34	2.76	73	23.32

# Tire Shop Micrometer Torque Wrench

- Use for checking wheel lug nuts to manufacturers recommended torque value

- Pull adjustment collar for easy and quick torque setting changes

- Scale markings are highly visible and easy to read

- Accurate in clockwise direction +/- 3% from 20% to 100% of full scale



- Tough "Tire Tread" rubber cover on head, lock ring and handle provides cushioning effect to reduce fatigue and tool damage

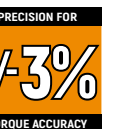

Cat. No.	Drive Size	Head Style	Primary Scale Range	Primary Scale Increments	Alt. Scale Range	Alt. Scale Increments	Tooth Count	Head Thickness (in)	Head Width (in)	Overall Length (in)	Product Weight
85088	1/2"	Standard - Protective Boot	30-250 in/lbs	2 in/lb	54.2 - 352.6 Nm	2.7 Nm	32	0.99	2.21	24.9	3.47

# Beam Torque Wrenches

- Pointer moves clockwise or counter-clockwise to measure torque in standard or metric scales

- Palm-fit handle

- 3/8" and 1/2" drives feature palm-fit handle that pivots on beam to maintain constant distance from drive point to load point for precise measurement

- 1/4" drive features ball-type handle to localize force, ensuring accuracy

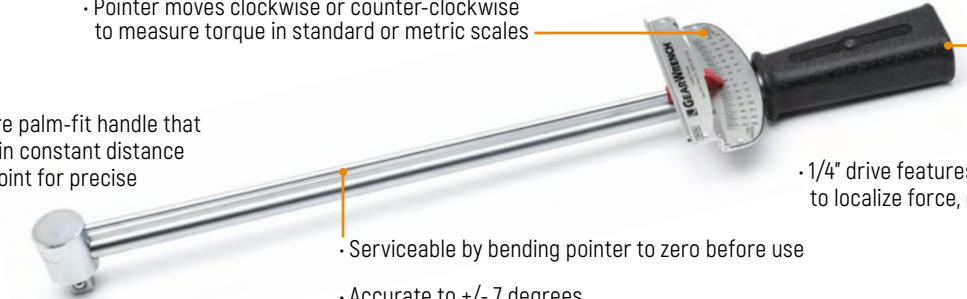

- Serviceable by bending pointer to zero before use

- Accurate to +/- 7 degrees

Cat. No.	Drive Size	Primary Scale Range	Primary Scale Increments	Alt. Scale Range	Alt. Scale Increments	Head Thickness (in)	Head Width (in)	Overall Length (in)	Product Weight (lb)
2955N	1/4"	0 - 80 in/lb	2.5 in/lb	0-9 Nm	25 Nm	1.325	0.8125	11.25	0.8
2956N	3/8"	0-800 in/lb	50 in/lb	0-90 Nm	12 Nm	1.325	0.8125	16	1
2957N	1/2"	0-150 ft/lb	5 ft/lb	0-190 Nm	27 Nm	1.25	1.125	20	2.5

# 120XP Electronic Flex Head Torque Wrenches with Angle

## Maximum Access and Accuracy

- "Target Torque Alert" and "Target Angle Alert" gives a warning as the target torque or target angle is approached, so there is less chance of over torquing a bolt
- Angle Accuracy (+/-1% of Reading) + (+/-1 degree @ angular velocity >10 degree/sec <180 degree/sec) + (+/-1 degree of test fixture)
- Ten torque setting presets for frequently repeated applications
- Accurate in clockwise direction +/- 2% from 20% to 100% of full scale

• Handle vibrates, buzzer sounds and LCD screen alerts when the target torque is reached

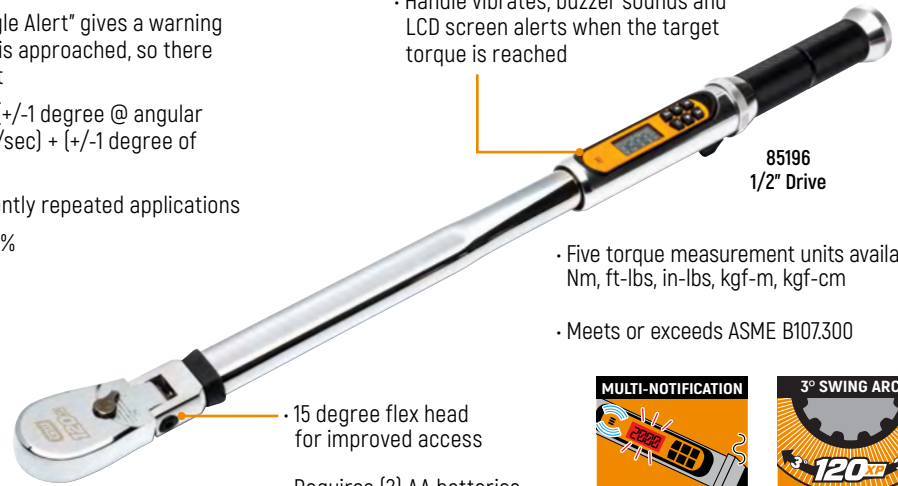

85196  
1/2" Drive

• Five torque measurement units available: Nm, ft-lbs, in-lbs, kgf-m, kgf-cm

• Meets or exceeds ASME B107.300

• 15 degree flex head for improved access

• Requires (2) AA batteries

PRECISION FOR  
**+/-2%**  
TORQUE ACCURACY

PRECISION FOR  
**+/-1%**  
ANGLE ACCURACY

MULTI-NOTIFICATION  
FOR EASE OF USE

3° SWING ARC  
FOR TIGHTER TURNS

FLEX HEAD  
FOR ACCESS

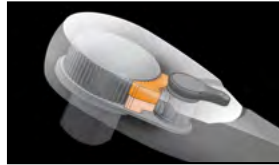

• Double-stacked pawls engage a 60-tooth gear providing exceptional strength, exceeding ASME specifications

SKU #	Drive Size	Primary Scale Range - Max Torque	Primary Scale Increments	Secondary Scale - Max Torque	Secondary Scale Increments	Tooth Count	Head Thickness (ins)	Head Width (ins)	Overall Length (ins)	Weight (lbs)
85194	1/4"	2.0 - 20 ft-lb	0.1 ft-lb	2.7 - 27.0 Nm	0.1 Nm	120	0.4	1.01	15.45	1.59
85195	3/8"	10 - 100 ft-lb	0.1 ft-lb	13.5 - 135 Nm	0.1 Nm	120	0.55	1.3	15.87	1.85
85196	1/2"	25 - 250 ft-lb	0.1 ft-lb	34 - 340 Nm	0.1 Nm	120	0.74	1.75	24.26	2.95

## Electronic Torque Wrenches

• "Target Torque Alert" and "Target Angle Alert" (85078/85079) gives a warning as the target torque or target angle is approached, so there is less chance of over torquing a bolt

• Angle Accuracy (+/-1% of Reading) + (+/-1 degree @ angular velocity >10 degree/sec <180 degree/sec) + (+/-1 degree of test fixture)

• Ten torque setting presets for frequently repeated applications

• Accurate in clockwise direction +/- 2% from 20% to 100% of full scale

• 15 degree flex head for improved access

• Handle vibrates, buzzer sounds and LCD screen alerts when the target torque is reached

• Handle and housing are oil and solvent resistant

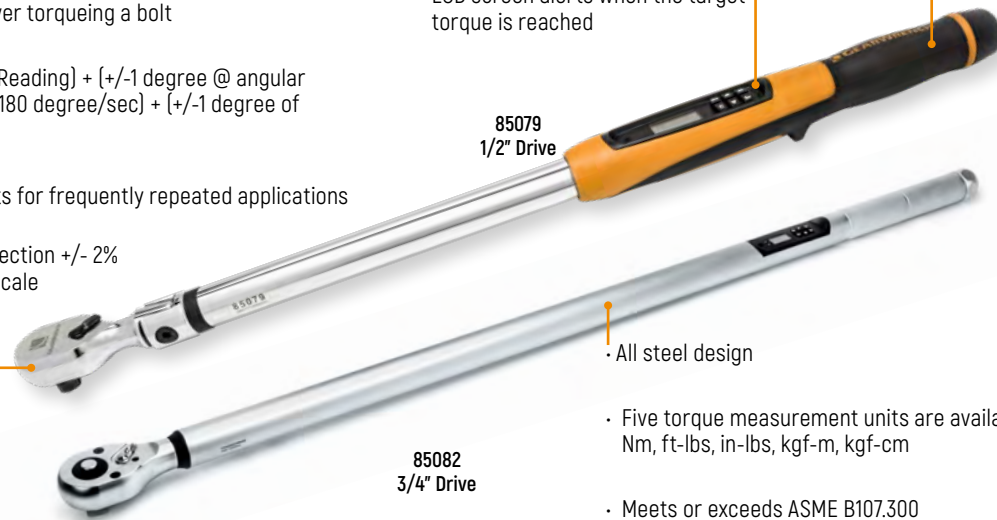

85079  
1/2" Drive

85082  
3/4" Drive

• All steel design

• Five torque measurement units are available: Nm, ft-lbs, in-lbs, kgf-m, kgf-cm

• Meets or exceeds ASME B107.300

PRECISION FOR  
**+/-2%**  
TORQUE ACCURACY

MULTI-NOTIFICATION  
FOR EASE OF USE

FLEX HEAD  
FOR ACCESS

SKU #	Drive Size	Head Style	Scale Range (Ft/lbs)	Scale Increments	Scale Range (In/lbs)	Scale Increments	Scale Range (Nm)	Scale Increments	Tooth Count	Head Thickness (ins)	Head Width (ins)	Overall Length (ins)	Weight (lbs)	Torque Angle Feature
85076	3/8"	Standard	74 ft/lb - 99.6 ft/lb	.1 ft/lb	88.5 in/lb - 1194 in/lb	.1 in/lb	10 - 135 Nm	.1 Nm	72	0.7	1.25	15.75	1.9	No
85077	1/2"	Standard	25.1 ft/lb - 250.8 ft/lb	.1 ft/lb	300 in/lb - 3008 in/lb	.1 in/lb	34 - 340 Nm	.1 Nm	72	0.85	1.58	25.75	2.9	No
85078	3/8"	Flex	10 - 100 ft/lbs	.1 ft/lb	89 in/lb - 1195 in/lb	.1 in/lb	10 - 135 Nm	1 Nm	72	0.7	1.25	16.75	2.07	Yes
85079	1/2"	Flex	25 - 250 ft/lbs	.1 ft/lb	266 in/lb - 3009 in/lb	.1 in/lb	34 - 340 Nm	1 Nm	72	0.85	1.58	25	3.08	Yes
85082	3/4"	Standard	73.8 - 738 ft/lbs	0.07 ft/lb	-	-	100-1000Nm	1 Nm	24	2.2	2.4	49.1	13.1	No
85085	1"	Standard	110 - 1107 ft/lbs	.1 ft/lb	-	-	150-1500Nm	1 Nm	24	2.3	2.4	49.1	13.1	No

# E-SPEC Torque Wrench

Introducing E-Spec, a connected electronic torque wrench designed specifically for production environments where a high level of precision is required. With +/- 1.5% torque accuracy and +/- 1% angle accuracy, E-Spec is a high-tech workhorse. E-Spec software allows users to set torque parameters and download torque process data via standard text format and all E-Spec wrenches incorporate GEARWRENCH 120XP™ technology that can turn fasteners in just a 3° swing-arc. E-Spec is the new standard for premium industrial torque application.

## Connected Torque Wrench for Assembly and Production

### Ease of Use:

- Low Profile Design for storage and access
- 3 Stage Alerts, Light, Feel, Sound
- Reversible Screen for Right and left Hand
- Rechargeable Battery Packs
- Recharging Stand
- (3) AAA battery cartridge option

### Performance:

- +/- 1.5% Accuracy
- +/- 1% Angle Measure Accuracy
- 100,000 Life Cycle Accuracy
- 360 Degree Torque Angle up to 999 Degree measure
- Auto Recalibration Alert
- Meets or exceeds ASME B107.300
- Serial Numbered

### Connectivity:

- PC Software Interface
- USB Connection
- Data Storage and Presets

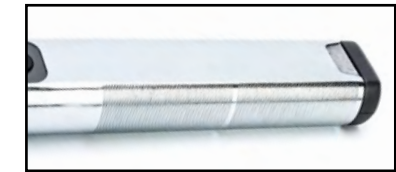

• Steel milled grip or optional molded handle overlay



• Simple 2 button menu driven interface

• 360 Visible Light bars with progressive torque indication



• Full polished tube

85236  
3/8" Drive

• Fixed or Interchangeable head options

PRECISION FOR  
**+/-1.5%**  
TORQUE ACCURACY

TORQUE ANGLE MEASURE  
FOR PRECISION

3° SWING ARC  
FOR TIGHTER TURNS

THIN PROFILE  
FOR ACCESS

FLEX HEAD  
FOR ACCESS

FIXED HEAD

INTERCHANGEABLE HEAD

## 120XP

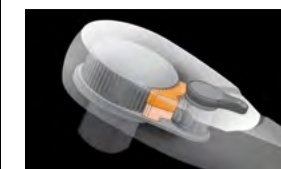

• Double-stacked pawls engage a 60-tooth gear providing exceptional strength, exceeding ASME specifications



• EVA and Injection box Storage



Cat. No.	Drive Size	Head Style	Scale Range (ft/lbs)	Scale Increments	Scale Range (in/lbs)	Scale Increments	Scale Range (Nm)	Scale Increments	Adapter Size	Tooth Count	(A) Head Thickness (mm)	(B) Head Width (mm)	(C) Overall Length (mm)	Product Weight (lb)
85235	1/4"	Fixed Head Standard	4-18 ft/lb	.1 ft/lb	44-220 in/lb	.1 in/lb	5-25Nm	0.1 Nm	N/A	60T/120 Pos.	24.4	25	46	0.15
85236	3/8"	Fixed Head Standard	1-20 ft/lb	.1 ft/lb	12-240 in/lb	.1 in/lb	14-28 Nm	0.1 Nm	N/A	60T/120 Pos.	34.4	34	51	0.31
85237	3/8"	Fixed Head Standard	15-74 ft/lb	.1 ft/lb	177-885 in/lb	.1 in/lb	20-100Nm	0.1 Nm	N/A	60T/120 Pos.	38	34	52	0.34
85238	1/2"	Fixed Head Standard	50-255 ft/lb	.1 ft/lb	600-3010 in/lb	.1 in/lb	68-340 Nm	0.1 Nm	N/A	60T/120 Pos.	44	41	72	0.66
85243	1/4"	Interchangeable Head	4-18 ft/lb	.1 ft/lb	44-220 in/lb	.1 in/lb	5-25Nm	0.1 Nm	9 x 12mm	60T/120 Pos.	NA	NA	NA	NA
85244	3/8"	Interchangeable Head	1-20 ft/lb	.1 ft/lb	12-240 in/lb	.1 in/lb	14-28 Nm	0.1 Nm	9 x 12mm	60T/120 Pos.	NA	NA	NA	NA
85245	3/8"	Interchangeable Head	15-74 ft/lb	.1 ft/lb	177-885 in/lb	.1 in/lb	20-100Nm	0.1 Nm	9 x 12mm	60T/120 Pos.	NA	NA	NA	NA
85246	1/2"	Interchangeable Head	50-255 ft/lb	.1 ft/lb	600-3010 in/lb	.1 in/lb	68-340 Nm	0.1 Nm	14 x 18mm	60T/120 Pos.	NA	NA	NA	NA

### Wrench Only

Cat. No.	Drive Size	Wrench Only
85235-01	1/4"	Fixed Head Standard
85236-01	3/8"	Fixed Head Standard
85237-01	3/8"	Fixed Head Standard
85238-01	1/2"	Fixed Head Standard
85243-01	1/4"	Interchangeable
85244-01	3/8"	Interchangeable
85245-01	3/8"	Interchangeable
85246-01	1/2"	Interchangeable

### Replacement Parts

Cat. No.	Part	
85250-01	Replacement Lithium Ion Battery for E-Spec Torque Wrench	
85250-02	Replacement (3) AAA Battery Cartridge only for E-Spec Torque Wrench	
85250-03	Replacement Charging stand for E-Spec Torque Wrench	
85250-04	Replacement AC Adapter for E-Spec Torque Wrench	
85250-05	Replacement USB Stick with instructions for E-Spec Torque Wrench	
85250-06	Replacement Case for 1/4" E-Spec Torque Wrench	
85250-07	Replacement Case for 1/2" E-Spec Torque Wrench	
85250-08	Replacement Handle for E-Spec Torque Wrench	



	1/4" Drive	3/8" Drive	1/2" Drive
E-Spec Fixed Head	85235	85236	85237
E-Spec Interchangeable Head	85243	85244	85245
Interchangeable Adapter	9 x 12mm	9 x 12mm	9 x 12mm
Drive	1/4"	3/8"	3/8"
Torque Range, in lb.	44-220	12-240	177-885
Torque Range, ft. lb.	4-18	1-20	15-74
Torque Range, Nm	5-25	14-28	20-100
Torque Range, Display	0.5% - 130% Full Scale	0.5% - 130% Full Scale	0.5% - 130% Full Scale
Torque Accuracy CW	+/-1.5% of reading	+/-1.5% of reading	+/-1.5% of reading
Torque Accuracy CCW	+/-2.5% + of reading	+/-2.5% + of reading	+/-2.5% + of reading
Angle Accuracy	+/- 1% of reading and +/- 1 degree	+/- 1% of reading and +/- 1 degree	+/- 1% of reading and +/- 1 degree
Angle Range	0-999.9 Degrees	0-999.9 Degrees	0-999.9 Degrees
Ratchet Style	120XP	120XP	120XP
Head Depth	0.86" (21.8mm)	1.05" (26.7mm)	1.05" (26.7mm)
Head Width	1" (25mm)	1.26" (32mm)	1.26" (32mm)
Swing Arc	3 degree	3 degree	3 degree
Storage Capacity	Simple mode: 2000 Production Mode: 6000	Simple mode: 2000 Production Mode: 6000	Simple mode: 2000 Production Mode: 6000
Number of Presets	100 Preset (P00-P99) 999 pcs for each (0-999)	100 Preset (P00-P99) 999 pcs for each (0-999)	100 Preset (P00-P99) 999 pcs for each (0-999)
Data management +	USB+Software	USB+Software	USB+Software
Rechargeable	Yes	Yes	Yes
Batteries Included	Li-ion battery pack, 2000mAh Rechargeable - Type C DATA/Charging	Li-ion battery pack, 2000mAh Rechargeable - Type C DATA/Charging	Li-ion battery pack, 2000mAh Rechargeable - Type C DATA/Charging
Alkline Battery cartridge option	Yes (3 AAA)	Yes (3 AAA)	Yes (3 AAA)
Progressive Lights	Yes - 30%, 50%, 70%, 90%, 98%	Yes - 30%, 50%, 70%, 90%, 98%	Yes - 30%, 50%, 70%, 90%, 98%
Buzzer	Yes - Off/Low/Mid/High	Yes - Off/Low/Mid/High	Yes - Off/Low/Mid/High
Decible Level	Variable - 40 to 70db	Variable - 40 to 70db	Variable - 40 to 70db
Vibration	Yes - Off/Low/Mid/High	Yes - Off/Low/Mid/High	Yes - Off/Low/Mid/High
LCD backlight	OLED, 5% to 100%	OLED, 5% to 100%	OLED, 5% to 100%
Approbation	CE for product, UL for rechargeable battery pack and power adapter	CE for product, UL for rechargeable battery pack and power adapter	CE for product, UL for rechargeable battery pack and power adapter
USB Access Location	Type C on the end	Type C on the end	Type C on the end
Calibration and Settings on Tool	Yes	Yes	Yes
Odometer of Torque Cycles	Yes	Yes	Yes
Adjustable Calibration/ Cert. Time Warning	Yes - Yes	Yes - Yes	Yes - Yes
All Steel Body	Yes	Yes	Yes
Methyl Propyl Ketone resistant display/buttons	Yes	Yes	Yes
Length	GW non flex: 15.37" (2.6+12.77) 390.5mm (66+324.5)	GW non flex: 15.53" (2.75+12.77) 394.5mm (70+324.5)	GW non flex: 15.53" (2.75+12.77) 394.5mm (70+324.5)
Weight	1.69Lb (0.21+147) / 770g (97+672)	1.83Lb (0.35+147) / 834g (161+672)	1.83Lb (0.35+147) / 834g (161+672)
Storage Case Included	Yes	Yes	Yes

## Interchangeable Torque Wrenches

• Torque accuracy of +/- 3% CW between 20% and 100% of wrench capability

• Pull adjustment collar for easy and quick torque setting changes

• Scale markings are highly visible and easy to read

• Midpoint on handle clearly marked for accuracy

• Knurled anodized aluminum handle reduces hand fatigue

• Full range of adapters with square style 9x12 and 14x9 drive tang

• Meets or exceeds ASME B107.300



Cat. No.	Adapter Size	Primary Scale Range (Nm)	Increments	Alt. Scale Range (In/lbs)	Scale Increments	Scale Range (ft/lbs)	Scale Increments	(A) Tube Diameter (mm)	(B) Handle Diameter (mm)	(C) Overall Length (mm)	Product Weight (lb)	(B) Head Width (mm)	(C) Overall Length (mm)	Product Weight (lb)
89470	9 x 12mm	1-5Nm	0.1 Nm	9-44 in/lb	0.89in/lb	1 - 4 ft/lb	1	143	232	210	0.66	25	46	0.15
89471	9 x 12mm	5-25Nm	0.1 Nm	44-221 in/lb	0.89in/lb	4 - 18 ft/lb	1	143	232	250	0.77	34	51	0.31
89472	9 x 12mm	20-100Nm	0.5 Nm	177 - 885 in/lb		15 - 74 ft/lb	4	224	322	422	2.31	34	52	0.34
89473	14 x 18mm	40-200Nm	1 Nm	354 - 1770 in/lb		30 - 148 ft/lb	1	224	322	525	2.86	41	72	0.66
89474	14 x 18mm	68-340Nm	2 Nm	602 - 3009 in/lb		50 - 251 Ft/lb	2	224	322	590	3.19	25	46	0.15

## Interchangeable Torque Wrench Sets

• Available in SAE and Metric



89450  
1/4" Drive

• 5-25Nm

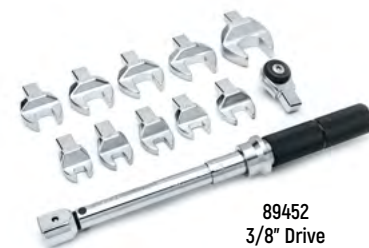

89452  
3/8" Drive

• 20-100Nm

Cat. No.	Description	Set Range	Adapter Size	Ratchet Head Adapter Drive Size	Case Length (mm)	Case Width (mm)	Case Height (mm)	Product Weight (lb)
89450	12pc SAE Interchangeable Torque Wrench 5-25Nm	5/16" - 13/16"	9 x 12mm	1/4"	290	185	50	2.88
89451	12pc Metric Interchangeable Torque Wrench 5-25Nm	8mm - 17mm	9 x 12mm	1/4"	290	185	50	2.88
89452	12pc SAE Interchangeable Torque Wrench 20-100Nm	5/16" - 13/16"	9 x 12mm	3/8"	470	270	62	4.42
89453	12pc Metric Interchangeable Torque Wrench 20-100Nm	8mm - 17mm	9 x 12mm	3/8"	470	270	62	4.42

Cat. No.	Style	Size	Adapter Size	89450	89451	89452	89453	Cat. No.	Style	Size	Adapter Size	89450	89451	89452	89453
89512	Open End	5/16"	9x12	X		X		89493	Open End	10MM	9x12		X		X
89513	Open End	11/32"	9x12	X		X		89494	Open End	11MM	9x12		X		X
89514	Open End	3/8"	9x12	X		X		89495	Open End	12MM	9x12		X		X
89515	Open End	7/16"	9x12	X		X		89496	Open End	13MM	9x12		X		X
89516	Open End	1/2"	9x12	X		X		89497	Open End	14MM	9x12		X		X
89517	Open End	9/16"	9x12	X		X		89498	Open End	15MM	9x12		X		X
89518	Open End	5/8"	9x12	X		X		89499	Open End	16MM	9x12		X		X
89519	Open End	11/16"	9x12	X		X		89500	Open End	17MM	9x12		X		X
89520	Open End	3/4"	9x12	X		X		89471	Interchangeable Torque Wrench	5 - 25 Nm	9x12	X	X		
89521	Open End	13/16"	9x12	X		X		89480	Ratchet Adapter	1/4"	9x12	X	X		
89491	Open End	8MM	9x12		X		X	89472	Interchangeable Torque Wrench	20-100 Nm	9x12			X	X
89492	Open End	9MM	9x12		X		X	89482	Ratchet Adapter	3/8"	9x12			X	X

## Preset Torque Wrenches

• Meets or exceeds ASME B107.300

• Accurate in clockwise direction +/- 3% from 20% to 100% of full scale

• Fixed Ratchet head or Square Drive receiver - 9x12mm and 14 x 18mm

• Matte chrome finish



85161  
3/8" Drive

• Solid Comfort grip handle

• Adjustment access at base of grip

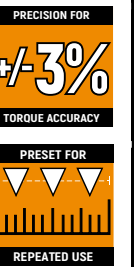

Cat. No.	Drive Size	Nm Range	in/lb Range	ft/lb Range	Tooth Count	(A) Head Thickness (mm)	(B) Head Width (mm)	(C) Overall Length (mm)	Product Weight (lb)
85160	1/4"	1-5Nm	9-44 in/lb	1 - 4 ft/lb	36	21	25	190	0.43
85161	3/8"	5-25Nm	44-221 in/lb	4 - 18 ft/lb	36	25	25	215	0.48
85162	3/8"	10-50Nm	89 - 442 in/lb	7 - 37 ft/lb	36	25	25	235	0.83
85163	1/2"	20-100Nm	177 - 885 in/lb	15 - 74 ft/lb	36	34	32	315	1.36
85164	1/2"	40-200Nm	354 - 1770 in/lb	30 - 148 ft/lb	36	34	32	463	2.73



Cat. No.	Adapter Size	Nm Range	in/lb Range	ft/lb Range	(C) Overall Length (mm)	Product Weight (lb)
89460	9 x 12mm	1-5 Nm	9-44 in/lb	1 - 4 ft/lb	164	0.39
89461	9 x 12mm	5-25 Nm	44-221 in/lb	4 - 18 ft/lb	189	0.44
89462	9 x 12mm	10-50 Nm	89 - 442 in/lb	7 - 37 ft/lb	209	0.74
89463	9 x 12mm	20-100 Nm	177 - 885 in/lb	15 - 74 ft/lb	289	1.23
89464	14 x 18mm	40-200 Nm	354 - 1770 in/lb	30 - 148 ft/lb	437	2.46

## Ratchet Heads

• Round Head Design

• 52 tooth 7-Degree Swing arc

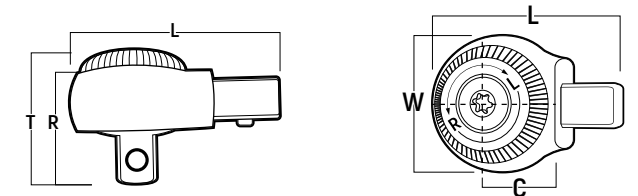

Cat. No.	Adapter Type	Drive Size	Adapter Size	(C) Center of Ratchet (mm)	Tooth Count	(R) Ratchet Thickness (mm)	(T) Total Head Thickness (mm)	(W) Head Width (mm)	(L) Overall Length (mm)	Product Weight (lb)
89480	Ratcheting Head	1/4"	9x12 MM	175	52T	19.5	24.4	25	46	0.15
89482	Ratcheting Head	3/8"	9x12 MM	175	52T	33.9	34.4	34	51	0.31
89484	Ratcheting Head	1/2"	9x12 MM	175	52T	37.4	38	34	52	0.34
89485	Ratcheting Head	1/2"	14x18 MM	25	52T	43.3	44	41	72	0.66

## 120XP Ratchet Heads

• 120 Position, double pawl design delivers 3 Degrees of swing arc

• Tear Drop Low profile head

• Flip Lever for quick forward and reverse

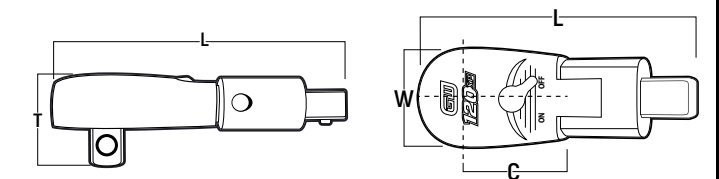

Cat. No.	Adapter Type	Drive Size	Adapter Size	(C) Center of Ratchet (mm)	Tooth Count	(T) Total Head Thickness (mm)	(W) Head Width (mm)	(L) Overall Length (mm)	Product Weight (lb)
89614	120XP Ratcheting Head	1/4"	9x12 MM	38	60T/120 Pos.	21.8	24.5	66	0.19
89615	120XP Ratcheting Head	3/8"	9x12 MM	38	60T/120 Pos.	26.7	32	70	0.35
89616	120XP Ratcheting Head	1/2"	14x18 MM	50	60T/120 Pos.	37	44	97	0.91
89617	120XP Flex Ratcheting Head	1/4"	9x12 MM	60	60T/120 Pos.	21.8	24.5	88	0.31
89618	120XP Flex Ratcheting Head	3/8"	9x12 MM	60	60T/120 Pos.	26.7	32	92	0.47
89619	120XP Flex Ratcheting Head	1/2"	14x18 MM	78	60T/120 Pos.	37	44	125	1.21

## Flare Nut Adapters



- Open Box Flare Nut
- 12pt configuration
- Chrome Plated

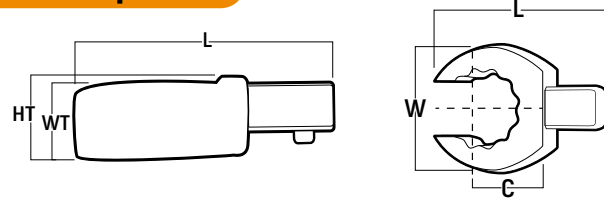

Cat. No.	Adapter Type	Size	Adapter Size	(C) Center of Wrench (mm)	(WT) Wrench Thickness (mm)	(HT) Head Thickness (mm)	(W) Head Width (mm)	(L) Overall Length (mm)	Product Weight (lb)
89590	Flare Nut	10mm	9x12	17.5	12	14.5	21.2	21.2	0.13
89591	Flare Nut	11mm	9x12	17.5	12	14.5	22.6	22.6	0.12
89592	Flare Nut	12mm	9x12	17.5	12	14.5	24.1	24.1	0.13
89593	Flare Nut	13mm	9x12	17.5	12	14.5	25.2	25.2	0.12
89594	Flare Nut	14mm	9x12	17.5	13	14.5	27.3	27.3	0.13
89595	Flare Nut	16mm	9x12	17.5	13	14.5	30.1	30.1	0.14
89596	Flare Nut	17mm	9x12	17.5	13	14.5	31.6	31.6	0.14
89597	Flare Nut	18mm	9x12	17.5	15	15	33.3	33.3	0.16
89598	Flare Nut	19mm	9x12	17.5	15	15	34.6	34.6	0.18
89599	Flare Nut	21mm	9x12	17.5	15	15	37.7	37.7	0.19
89600	Flare Nut	22mm	9x12	17.5	15	15	39.3	39.3	0.2
89601	Flare Nut	11/32"	9x12	17.5	8	14.7	17.6	17.6	0.09
89602	Flare Nut	3/8"	9x12	17.5	12	14.5	21.2	21.2	0.13
89603	Flare Nut	7/16"	9x12	17.5	12	14.5	22.6	22.6	0.12
89604	Flare Nut	1/2"	9x12	17.5	12	14.5	25.2	25.2	0.12
89605	Flare Nut	9/16"	9x12	17.5	13	14.5	27.3	27.3	0.13
89606	Flare Nut	5/8"	9x12	17.5	13	14.5	30.1	30.1	0.14
89607	Flare Nut	11/16"	9x12	17.5	15	15	33.3	33.3	0.16
89608	Flare Nut	3/4"	9x12	17.5	15	15	34.6	34.6	0.18
89609	Flare Nut	13/16"	9x12	17.5	15	15	37.7	37.7	0.19
89610	Flare Nut	7/8"	9x12	17.5	15	15	39.3	39.3	0.2
89611	Flare Nut	15/16"	9x12	25	15	21.5	38	38	0.24
89612	Flare Nut	1"	9x12	31	17.5	21.5	42	42	0.35

## Open End Adapters



- Open end wrench style
- Chrome plated

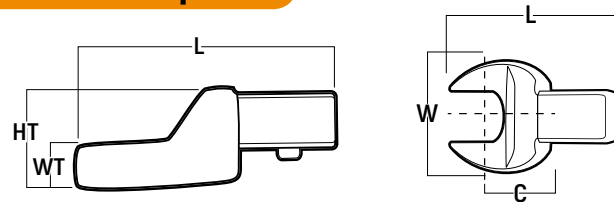

Cat. No.	Adapter Type	Size	Adapter Size	(C) Center of Wrench (mm)	(WT) Wrench Thickness (mm)	(HT) Head Thickness (mm)	(W) Head Width (mm)	(L) Overall Length (mm)	Product Weight (lb)
89490	Open End	7mm	9x12	17.5	5.7	14.7	20.7	20.7	0.09
89491	Open End	8mm	9x12	17.5	5.7	14.7	22	22	0.09
89492	Open End	9mm	9x12	17.5	5.7	14.7	23.5	23.5	0.08
89493	Open End	10mm	9x12	17.5	5.7	14.7	24.8	24.8	0.09
89494	Open End	11mm	9x12	17.5	5.7	14.7	26	26	0.09
89495	Open End	12mm	9x12	17.5	5.7	14.7	27.5	27.5	0.09
89496	Open End	13mm	9x12	17.5	5.7	14.7	28.8	28.8	0.11
89497	Open End	14mm	9x12	20	7.7	14.7	31.5	31.5	0.11
89498	Open End	15mm	9x12	20	7.7	14.7	33.5	33.5	0.11
89499	Open End	16mm	9x12	20	7.7	14.7	36	36	0.13
89500	Open End	17mm	9x12	20	7.7	14.7	37.7	37.7	0.13
89501	Open End	18mm	9x12	20	7.7	14.7	39	39	0.16
89502	Open End	19mm	9x12	20	7.7	14.7	41.6	41.6	0.16

## Open End Adapters continued



Cat. No.	Adapter Type	Size	Adapter Size	(C) Center of Wrench (mm)	(WT) Wrench Thickness (mm)	(HT) Head Thickness (mm)	(W) Head Width (mm)	(L) Overall Length (mm)	Product Weight (lb)
89503	Open End	17mm	14x18	25	9	21.5	37	59.5	0.3
89504	Open End	18mm	14x18	25	9	21.5	38.6	60	0.32
89505	Open End	19mm	14x18	25	9	21.5	40.6	60.5	0.32
89506	Open End	21mm	14x18	25	11	21.5	45.2	61	0.38
89507	Open End	22mm	14x18	25	11	21.5	47.3	62	0.36
89508	Open End	24mm	14x18	25	11	21.5	50.8	63.1	0.37
89509	Open End	27mm	14x18	32.5	13.5	21.5	58.7	69	0.48
89510	Open End	30mm	14x18	32.5	13.5	21.5	62.7	70.6	0.54
89511	Open End	32mm	14x18	32.5	13.5	21.5	65.2	72.1	0.54
89512	Open End	5/16"	9x12	17.5	5.70	14.7	22.00	37.90	0.09
89513	Open End	11/32"	9x12	17.5	5.70	14.7	23.50	37.90	0.09
89514	Open End	3/8"	9x12	17.5	5.70	14.7	24.80	39.90	0.09
89515	Open End	7/16"	9x12	17.5	5.7	14.7	26	39.1	0.09
89516	Open End	1/2"	9x12	17.5	5.7	14.7	28.8	40	0.11
89517	Open End	9/16"	9x12	20	7.7	14.7	31.5	43	0.11
89518	Open End	5/8"	9x12	20	7.7	14.7	36	44	0.13
89519	Open End	11/16"	9x12	20	7.7	14.7	39	45	0.16
89520	Open End	3/4"	9x12	20	7.7	14.7	41.6	46	0.16
89521	Open End	13/16"	9x12	25	11	21.5	45.2	52	0.27
89522	Open End	7/8"	9x12	25	11	21.5	47.3	53	0.28
89523	Open End	15/16"	9x12	25	11	21.5	50.8	54	0.28
89524	Open End	11/16"	14x18	25	9	21.5	38.6	60	0.32
89525	Open End	3/4"	14x18	25	9	21.5	40.6	60.5	0.32
89526	Open End	13/16"	14x18	25	11	21.5	45.2	61	0.38
89527	Open End	7/8"	14x18	25	11	21.5	47.3	62	0.36
89528	Open End	15/16"	14x18	25	11	21.5	50.8	63.1	0.37
89529	Open End	1"	14x18	32.5	13.5	21.5	58.7	69	0.48
89530	Open End	1-1/6"	14x18	32.5	13.5	21.5	58.7	69	0.48
89531	Open End	1-1/8"	14x18	32.5	13.5	21.5	62.7	70.6	0.54
89532	Open End	1-3/16"	14x18	32.5	13.5	21.5	62.7	70.6	0.54
89533	Open End	1-1/4"	14x18	32.5	13.5	21.5	65.2	72.1	0.54

## Box End Adapters



- Box End Style
- 12pt Configuration
- Chrome Plated

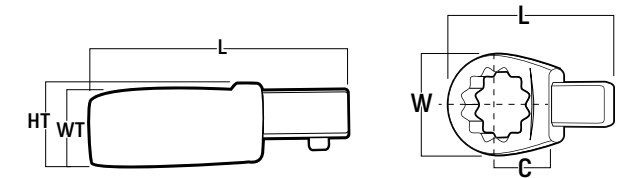

Cat. No.	Adapter Type	Size	Adapter Size	(C) Center of Wrench (mm)	(WT) Wrench Thickness (mm)	(HT) Head Thickness (mm)	(W) Head Width (mm)	(L) Overall Length (mm)	Product Weight (lb)
89540	12pt Box End	7mm	9x12	17.5	8	14.7	13.1	40.3	0.08
89541	12pt Box End	8mm	9x12	17.5	8	14.7	13.1	40.3	0.09
89542	12pt Box End	9mm	9x12	17.5	8	14.7	17.6	42.5	0.09
89543	12pt Box End	10mm	9x12	17.5	8	14.7	17.6	42.5	0.1
89544	12pt Box End	11mm	9x12	17.5	8	14.7	19	43.5	0.09
89545	12pt Box End	12mm	9x12	17.5	12.2	14.7	20.3	44	0.11
89546	12pt Box End	13mm	9x12	17.5	12.2	14.7	21.1	44.5	0.12

## Box End Adapters continued



Cat. No.	Adapter Type	Size	Adapter Size	[C] Center of Wrench (mm)	[WT] Wrench Thickness (mm)	[HT] Head Thickness (mm)	[W] Head Width (mm)	[L] Overall Length (mm)	Product Weight (lb)
89547	12pt Box End	14mm	9x12	17.5	12.2	14.7	23.4	45.5	0.11
89548	12pt Box End	15mm	9x12	17.5	12.2	14.7	24.4	48	0.13
89549	12pt Box End	16mm	9x12	17.5	13.2	14.7	26.4	47	0.12
89550	12pt Box End	17mm	9x12	17.5	13.2	14.7	27.4	48	0.13
89551	12pt Box End	18mm	9x12	17.5	13.2	14.7	28.9	48.3	0.12
89552	12pt Box End	19mm	9x12	17.5	13.2	14.7	31	49.5	0.14
89553	12pt Box End	21mm	9x12	17.5	14.7	14.7	33.4	50.5	0.16
89554	12pt Box End	22mm	9x12	17.5	14.7	14.7	35	51.5	0.16
89555	12pt Box End	17mm	14x18	25	12.5	21.5	27.5	64	0.3
89556	12pt Box End	18mm	14x18	25	12.5	21.5	29.5	64.5	0.3
89557	12pt Box End	19mm	14x18	25	12.5	21.5	31	66	0.3
89558	12pt Box End	21mm	14x18	25	15	21.5	33	67.1	0.32
89559	12pt Box End	22mm	14x18	25	15	21.5	35	68.1	0.32
89560	12pt Box End	24mm	14x18	25	15	21.5	38	69.1	0.34
89561	12pt Box End	27mm	14x18	31	17.5	21.5	42	77.3	0.36
89562	12pt Box End	30mm	14x18	31	17.5	21.5	45.1	78.7	0.4
89563	12pt Box End	32mm	14x18	31	17.5	21.5	48	79.8	0.4
89564	12pt Box End	5/16"	9x12	17.5	8	14.7	13.1	40.3	0.09
89565	12pt Box End	11/32"	9x12	17.5	8	14.7	17.6	42.5	0.1
89566	12pt Box End	3/8"	9x12	17.5	8	14.7	17.6	42.5	0.1
89567	12pt Box End	7/16"	9x12	17.5	8	14.7	19	43.5	0.09
89568	12pt Box End	1/2"	9x12	17.5	12.2	14.7	21.1	44.5	0.12
89569	12pt Box End	9/16"	9x12	17.5	12.2	14.7	23.4	45.5	0.11
89570	12pt Box End	5/8"	9x12	17.5	13.2	14.7	26.4	47	0.12
89571	12pt Box End	11/16"	9x12	17.5	13.2	14.7	28.9	48.3	0.12
89572	12pt Box End	3/4"	9x12	17.5	13.2	14.7	31	49.5	0.14
89573	12pt Box End	13/16"	9x12	17.5	14.7	14.7	33.4	50.5	0.16
89574	12pt Box End	7/8"	9x12	17.5	14.7	14.7	35	51.5	0.16
89575	12pt Box End	15/16"	9x12	25	15	21.5	38	60	0.27
89576	12pt Box End	1"	9x12	31	21.5	21.5	42	68	0.37
89577	12pt Box End	1-1/16"	9x12	31	21.5	21.5	42	68	0.36
89578	12pt Box End	1-1/8"	9x12	31	21.5	21.5	45.1	69.5	0.38
89579	12pt Box End	11/16"	14x18	25	21.5	21.5	29.5	64.5	0.3
89580	12pt Box End	3/4"	14x18	25	21.5	21.5	31	66	0.3
89581	12pt Box End	13/16"	14x18	25	21.5	21.5	33	67.1	0.32
89582	12pt Box End	7/8"	14x18	25	21.5	21.5	35	68.1	0.32
89583	12pt Box End	15/16"	14x18	25	21.5	21.5	38	69.1	0.34
89584	12pt Box End	1"	14x18	31	21.5	21.5	42	77.3	0.36
89585	12pt Box End	1-1/16"	14x18	31	17.5	21.5	42	77.2	0.36
89586	12pt Box End	1-1/8"	14x18	31	17.5	21.5	45.1	78.7	0.4
89587	12pt Box End	1-3/18"	14x18	31	17.5	21.5	45.1	78.7	0.4
89588	12pt Box End	1-1/4"	14x18	31	17.5	21.5	48	79.8	0.4

## Torque Screwdrivers



89621  
Torque  
Screwdriver

• Accuracy to +/- 6%

• Comfort grip, high torque handle



PRECISION FOR  
**+/- 6%**  
TORQUE ACCURACY

• Drive quick release adapter

• Locking sleeve device

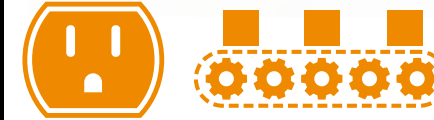

• Meets or exceeds ASME B107.300

89625  
Mini Torque  
Screwdriver



Cat. No.	Description	Primary Range	Increments	Accuracy	Handle Thickness (mm)	Handle Length (mm)	Overall Length (mm)	Product Weight (lb)
89621	Torque Screwdriver [1/4"]	1 to 6 Nm	0.1	+/- 6%	37	95	195	0.75
89622	Torque Screwdriver [1/4"]	21 to 165 in/oz	0.01	+/- 6%	37	95	180	0.51
89623	Torque Screwdriver [1/4"]	5 to 25 in/lbs	0.5	+/- 6%	37	95	195	0.75
89624	Torque Screwdriver [1/4"]	10 to 50 in/lbs	1	+/- 6%	37	95	195	0.75
89625	Mini Torque Screwdriver [5/32"]	5-60 cNm	0.5	+/- 6%	26	25	100	0.23

## Torque Screwdriver Set



- Designed for electrical service and assembly applications
- Popular 10-50 in/lb torque driver
- Includes 1/4" quick release chuck
- Comes with 19 special length adapters as shown
- Meets or exceeds ASME B107.300
- Storage case included

**WARNING:** This is not an insulated tool. Grip is for comfort only and will not protect against electrical shock.

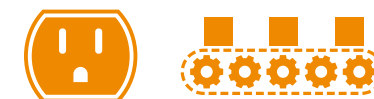

PRECISION FOR  
**+/- 6%**  
TORQUE ACCURACY

### 20 Piece Screwdriver Set Contents

Cat. No.	Type	Size	Overall Length	Cat. No.	Type	Size	Overall Length
89624	Torque Screwdriver [1/4"]	10 to 50 in/lbs	195	89020 - 06	Square	#2	3-1/2
89020 - 01	Phillips	#1	3-1/2	89020 - 11	Square	#1	6"
89020 - 02	Phillips	#2	3-1/2	89020 - 12	Square	#2	6"
89020 - 07	Phillips	#1	6"	89020 - 13	Nut Driver	3/16	6"
89020 - 08	Phillips	#2	6"	89020 - 14	Nut Driver	1/4	6"
89020 - 03	Slotted	3/16	3-1/2	89020 - 15	Nut Driver	5/16	6"
89020 - 04	Slotted	1/4	3-1/2	89020 - 16	Nut Driver	11/32	6"
89020 - 09	Slotted	3/16	6"	89020 - 17	Nut Driver	3/8	6"
89020 - 10	Slotted	1/4	6"	89020 - 18	Nut Driver	7/16	6"
89020 - 05	Square	#1	3-1/2	89020 - 19	Nut Driver	1/2	6"



## Torque Multipliers

- Internal planetary gear system provides strength and durability

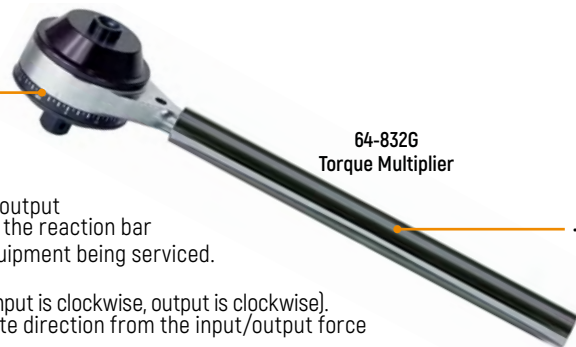

64-832G  
Torque Multiplier

- The torque multiplier with an impact socket on the output square is placed on the fastener to be turned with the reaction bar restrained against some substantial part of the equipment being serviced.

- Low input torque is required and can be applied easily by one person

- Input and output rotation directions are the same (if input is clockwise, output is clockwise). Torque reaction on the reaction arm is in the opposite direction from the input/output force

Cat. No.	Input Drive	Output Drive	Max Input (ft/lb)	Max Output (ft/lb)	Gear Ratio	Torque Ratio	Torque Multiplier Type	Head Thickness	Head Width	Overall Length	Product Weight (lb)	Replacement Square Drive
64-830G	1/2"	3/4"	227 ft/lb	750 ft/lb	4.0:1	3.3:1	Reaction Bar	3.3"	2.812"	8.531"	4.7	
64-832G	1/2"	3/4"	200 ft/lb	1200 ft/lb	6.3:1	6.0:1	Reaction Bar	4"	3.94"	14.125"	9.1	64-850G
64-833G	3/4"	1"	500 ft/lb	2000 ft/lb	4.7:1	3.5:1	Reaction Bar	4.5"	3.8"	19.5"	14	
64-834G	1/2"	1"	162 ft/lb	2200 ft/lb	15.0:1	13.6:1	Reaction Bar	5.7"	4.031"	20"	20.6	64-851G
64-836G	1/2"	1"	173 ft/lb	3200 ft/lb	20.2:1	18.5:1	Reaction Bar	6.5"	4.031"	20"	22.1	64-852G

## Bench Top Torque Testers

- Designed for inspection of torque wrenches in production workshop;
- Accuracy: +/- 1%
- Three modes: Track, Peak, First Peak
- Lb.ft, Lb.in, Nm and Kg.cm
- Backlight for dark working condition
- Four screw bolts that can be fixed on the workbench or other base plate;

- Built-in rechargeable lithium battery, or full time AC connection
- Percentage error between the measured value and the set value, no more manual calculation;
- 1500 data storage
- Data upload through the USB interface;
- 10 minutes automatic shutdown function
- Audible and visual alarm



89633  
1/2" drive

Cat. No.	Drive Size	Primary Range	Accuracy	(A) Height (in)	(B) Width (in)	(C) Length (in)	Product Weight (lb)
89631	1/4"	Bench Tester 10-100 In/lb [11-113.3Nm]	+/- 1%	3.35"	5.35"	5.31"	4.8
89632	3/8"	Bench Tester 3-30 Ft/lb [41-40.7Nm]	+/- 1%	3.35"	5.35"	5.31"	5.7
89633	1/2"	Bench Tester 10-100 FT LB [13.6-135.6Nm]	+/- 1%	3.35"	5.35"	5.31"	6.4
89634	1/2"	Bench Tester 25-250 Ft/lb [33.9-339.0Nm]	+/- 1%	3.35"	5.35"	5.31"	6.8
89635	3/4"	Bench Tester 75-750 FT/LB [101.7-1016.9Nm]	+/- 1%	3.35"	5.35"	5.31"	7.5

## Touch Screen and Transducer

- Within 10% - 100% of full load value, accuracy +/- 0.5%;
- 7" color touch screen;
- Three Modes: Track, Peak, First peak
- Three Interfaces: Regular, Preset, Curve
- Multiple Units: N.m, cN.m, kg.m, ck.gm, Lb.ft, Lb.in, Oz.in
- Easy menu operation mode;
- Upload data through the USB interface;
- Compatible with 89640 Torque Testing Stand

- Automatically store 15 test reading while testing the torque wrench;
- Preset parameter 100 groups;
- 5000 data can be stored;



89639  
1/2" drive

Cat. No.	Drive Size	Primary Range	Accuracy	(A) Height (in)	(B) Width (in)	(C) Length (in)	Product Weight (lb)
89636	1/4"	Bench Tester 10-100 In/lb [11-113.3Nm]	+/- .5%	3"	4"	4"	4.6
89637	3/8"	Bench Tester 3.0-30 Ft/lb [41-40.7Nm]	+/- .5%	3"	4"	4"	5.1
89638	1/2"	Bench Tester 10-100 FT LB [13.6-135.6Nm]	+/- .5%	3"	4"	4"	5.4
89639	1/2"	Bench Tester 30-300 Ft/lb [40.7-406.7Nm]	+/- .5%	3"	4"	4"	5.6

## Torque Testing Stand and Fixture

- Large diameter wheel for easy and smooth application

- Instrument rack tray is adjustable for ease of use

- Adjustable to accommodate different wrench lengths

- Torque tester not included



Cat. No.	Drive Size	Primary Range
89636	1/4"	Bench Tester 10-100 In/lb [11-113.3Nm]
89637	3/8"	Bench Tester 3.0-30 Ft/lb [41-40.7Nm]
89638	1/2"	Bench Tester 10-100 FT LB [13.6-135.6Nm]
89639	1/2"	Bench Tester 30-300 Ft/lb [40.7-406.7Nm]

Cat. No.	Drive Size	(A) Height (in)	(B) Width (in)	(C) Length (in)	Product Weight (lb)
89640	1/4", 3/8" & 1/2"	23.2"	114"	33.9"	71.7

## Torque Wrench Replacement Parts

Wrench No.	Description	Kit Cat. No.
<b>120XP Torque Wrench Repair Kits</b>		
85171	WR TRQ Micro 1/4" DR. 30-200 in/lb 120XP	81099P
85176	WR TRQ Micro 3/8" DR. 10-100FT/LB 120XP	81227P
85181	WR TRQ Micro 1/2" DR. 30-250FT/LB 120XP	81339P
85174	WR TRQ Micro 3/8" DR. 30-250 IN 120XP	81227P
85180	WR TRQ Micro 1/2" DR. 20-150 FT 120XP	81339P
85188	TRQ WR Flex Head 3/8" DR. 10-100 FT-LB 120XP	81227P
85189	TRQ WR Flex Head 1/2" DR. 30-250FT-LB 120XP	81339P
<b>Standard Torque Wrenches</b>		
85060	WR TRQ Micro 1/4" DR. 30-200 IN/LB	89224
85061	WR TRQ Micro 3/8" DR. 30-250FT/LB	89225
85062	WR TRQ Micro 3/8" DR. 10-100FT/LB	89225
85063	WR TRQ Micro 1/2" DR. 20-150 FT	89226
85066	WR TRQ Micro 1/2" DR. 30-250 FT	89226
85086	TRQ WR FLEX HEAD 3/8" DR. 5-75 FT-LB	89225
85087	TRQ WR FLEX HEAD 1/2" DR. 30-250 FT-LB	89228
85088	TRQ WR TIRE SHOP 1/2" DR. 30-250 FT-LB	89226
85065	TRQ WR Micro 3/4" DR. 100-600 FT LB	89227

Wrench No.	Description	Kit Cat. No.
<b>E-Spec Torque Wrenches</b>		
85235	1/4" DR. 5-25NM FIXED HEAD E-SPEC ETW	81099P
85236	3/8" DR. 14 - 272 NM FIXED HEAD E-SPEC ETW	81227P
85237	3/8" DR. 20-100NM FIXED HEAD E-SPEC ETW	81339P
85238	1/2" DR. 68-340 NM FIXED HEAD E-SPEC ETW	81227P
85235-01	1/4" DR. 5-25NM FIXED HEAD E-SPEC ETW - ONLY	81099P
85236-01	3/8" DR. 14 - 272 NM FIXED HEAD E-SPEC ETW - ONLY	81227P
85237-01	3/8" DR. 20-100NM FIXED HEAD E-SPEC ETW - ONLY	81339P
85238-01	1/2" DR. 68-340 NM FIXED HEAD E-SPEC ETW - ONLY	81227P
<b>Interchangeable Ratchet Heads</b>		
89614	120XP RATCHETING HEAD 1/4" DR. 9X12	81099P
89615	120XP RATCHETING HEAD 3/8" DR. 9X12	81227P
89616	120XP RATCHETING HEAD 1/2" DR. 14X8	81339P
89617	120XP FLEX RATCHETING HEAD 1/4" DR. 9X12	81099P
89618	120XP FLEX RATCHETING HEAD 3/8" DR. 9X12	81227P
89619	120XP FLEX RATCHETING HEAD 1/2" DR. 14X18	81339P

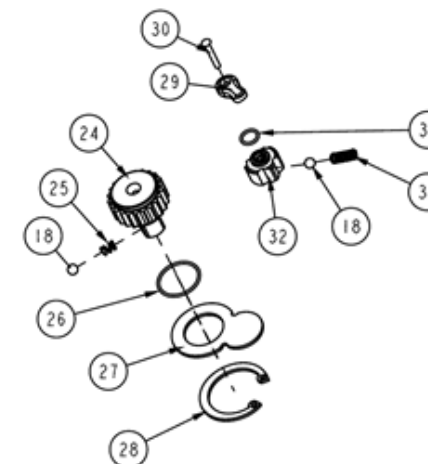



## Warranty Information

GEARWRENCH branded torque wrenches have a one year limited part warranty. Accuracy standards for calibration are warranted for 90 days from the date of the buyer delivery.

Apex Tool Group offers a comprehensive warranty and service plan with exclusive torque wrench repair partners for all GEARWRENCH and previously Apex Tool Group manufactured torque wrenches.

Warranty/Repair Partners are: Angle Repair (U.S.A.) and McCann Equipment (Canada). See below contact information.

### Warranty within warranty period: (1 year part warranty)

Repair Center will determine if wrench can be repaired. If wrench is determined to be unrepairable or parts are no longer available, a new wrench at same or equivalent value will be provided. Wrenches found to be misused or abused are not covered under this warranty.

### Repair outside of warranty:

Repair Center will determine if wrench can be repaired. If not, Customers will be offered the opportunity to purchase a new GEARWRENCH branded Torque Wrench of equal value at a special replacement price. Any current or previously Apex Manufactured Torque Wrenches are covered under this plan. Repair Center will determine and advise of eligibility.

Wrenches found to be misused or abused are not covered under this warranty. Transactions for the purchase or repair of new Torque Wrenches are between the Customer and Repair Center.

### Recalibration:

Apex Tool Group, will continue to offer a recalibration service through our exclusive Repair centers below. Wrenches found to be outside of calibration within 90 days from date of the buyer delivery will be recalibrated at no charge. Service Centers offer recalibration at cost outside of warranty.

## Torque Wrench Warranty Service Information:

### Micrometer and Electronic Torque Products:

In the U.S.A.  
Angle Repair & Calibration Service, Inc.  
175 Angle Drive  
Beckley, West Virginia 25801  
Phone: 304-253-5729

### Micrometer and Electronic Torque Products: In CANADA

McCann Equipment LTD.  
2750 Coventry Road, Oakville, Ontario L6H 6R1  
Phone: (905) 829-3393 Fax: (905)829-0633

McCann Equipment LTD.  
Equipment McCann LTÉE  
10255 Cote de Liesse, Dorval, Quebec H9P 1A3  
Phone: (514) 636-6344 Fax: (514) 636-0365

McCann Equipment LTD.  
1489 Dublin Avenue, Winnipeg, Manitoba R3E 3G8  
Phone: (204) 774-2277 Fax: (204) 774-2358

McCann Equipment LTD.  
4120-97th Street,  
Edmonton, Alberta T6E 5V6  
Phone: (780) 414-1808 Fax: (780) 414-1865

Canada West Torque Tools  
(Division of McCann Equipment Ltd.)  
#7-7533-135th Street, Surrey,  
British Columbia V3W 0N6  
Phone: (604) 596-4077 Fax: (604) 596-6479



All GEARWRENCH torque wrenches are properly calibrated and tested prior to shipment from our factories in accordance with ASME standards. Each wrench contains a dated Certificate of Calibration with the corresponding serial number and testing results and kept on file.

Copies of original Certificates are retained on file at Apex Tool Group for a period of 3 years and available upon request.

In addition, Apex Tool provides additional Certification on selected models accompanied with the Suffix CERT and can be ordered with other products.