

# PFQ83HSHWWW

## GE Profile™ 4.6 cu. ft. Capacity UltraFast Combo with SmartDispense™ Technology Washer/Dryer

### DIMENSIONS AND INSTALLATION INFORMATION (IN INCHES)

ELECTRIC RATING	
120V	11.0A, 60Hz

#### INSTALLATION INFORMATION:

For complete information, see installation instructions packed with your Combo.

#### CIRCUIT REQUIREMENTS:

An individual, properly grounded branch circuit, protected by a 15-amp circuit breaker or a time-delay fuse, is required.

#### NOTE:

Combo wall outlet must be located within 36" of service cord entry and accessible when combo is mounted in position.

**INCLUDED POWER CORD LENGTH:** Up to 66"

**INCLUDED DRAIN HOSE LENGTH:** Up to 60"

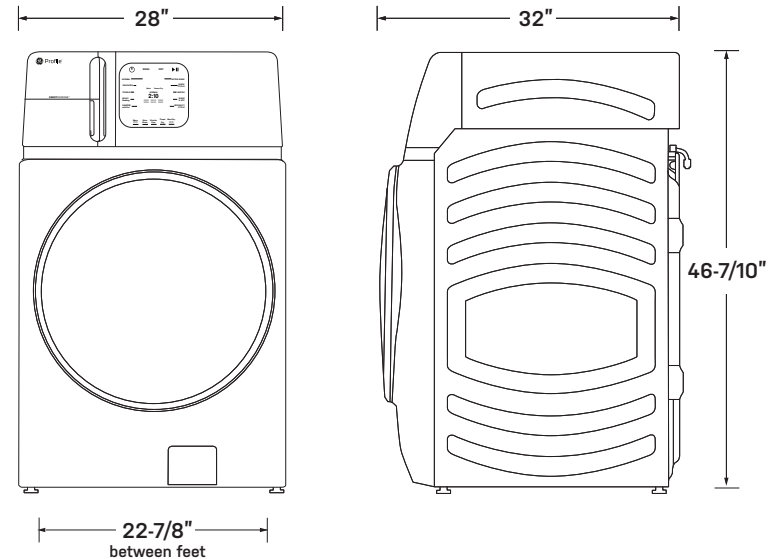
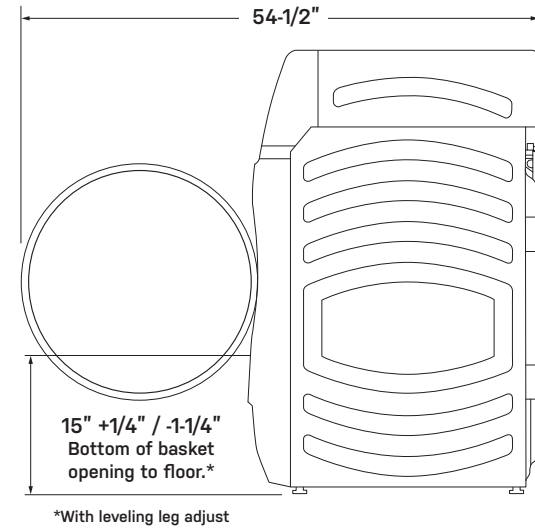

For answers to your Monogram, Café™, GE Profile™ or GE Appliances product questions, visit our website at [geappliances.com](http://geappliances.com) or call GE Answer Center® Service, 800.626.2000.



Specification Revised 5/24

# PFQ83HSHWWW

## GE Profile™ 4.6 cu. ft. Capacity UltraFast Combo with SmartDispense™ Technology Washer/Dryer

### ALCOVE OR CLOSET INSTALLATION:

- Approved for closet installation. Closet doors must be louvered or otherwise ventilated and have at least 60 square inches (387.1 cm<sup>2</sup>) of open area.

### NO VENTING REQUIRED.

- Minimum clearances between Combo cabinet and adjacent walls or other surfaces are: 0" all sides and top.\*

### MINIMUM CLEARANCE OTHER THAN ALCOVE OR CLOSET INSTALLATIONS:

- Minimum clearances to combustible surfaces 0" all sides and top.\*

### WEIGHT

- Carton weight 323 lbs.
- Product weight 302 lbs.

### ACCESSORIES\*\*

GE Part Number	Description
GFR0728SNWW	7" RightHeight™ Riser/Carbon – White
WX14X10011	Washer Hoses – 6' Stainless Steel 90° Elbows; 2-pack
PM14X10002	Washer Hoses – 4' Rubber; 2-pack
WH1X2267	Washer Hoses – Filter Screen; 1-per
WH41X36697	Washer Hose – Unicoupler (sink faucet hook-up)
WX14X10014	1' Hose Splitter 2-way (Short Hose with Y-Adapter)
WH49X316	Drain Hose Extension Kit – Approx. 44"
GFAPC120V	4-Prong 240V to 120V Plug Adapter
PM14X10056	Filter – Appliance Brush Set (Internal Area of Combo)
WH01X35719	Filter Foam Pad
WX08X10070	4" Duct Vent Cap
WR97X212	Touch-Up Paint – 0.6 oz.
PM7X2	Floor Plan – Low-Profile Pan with Drain (White)

### WARRANTY

Labor Warranty	Limited 1-year entire appliance
Parts Warranty	Limited 1-year entire appliance Limited 5-year sealed system Limited 10-year motor

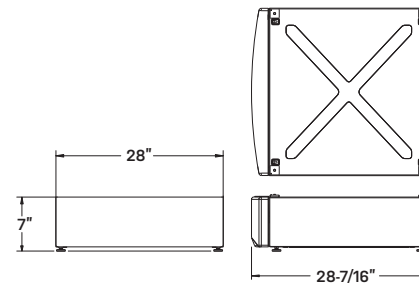
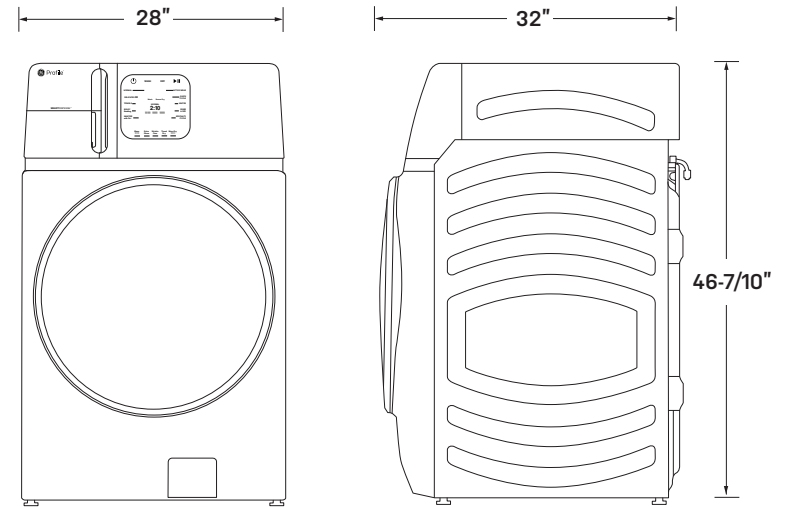

### RISER DIMENSIONS (IN INCHES) GFR0728SNWW – White

This optional 7" riser raises the door opening and height of the Combo unit. On a riser this unit is no longer ADA compliant. Not suggested for installation on a 16" pedestal.

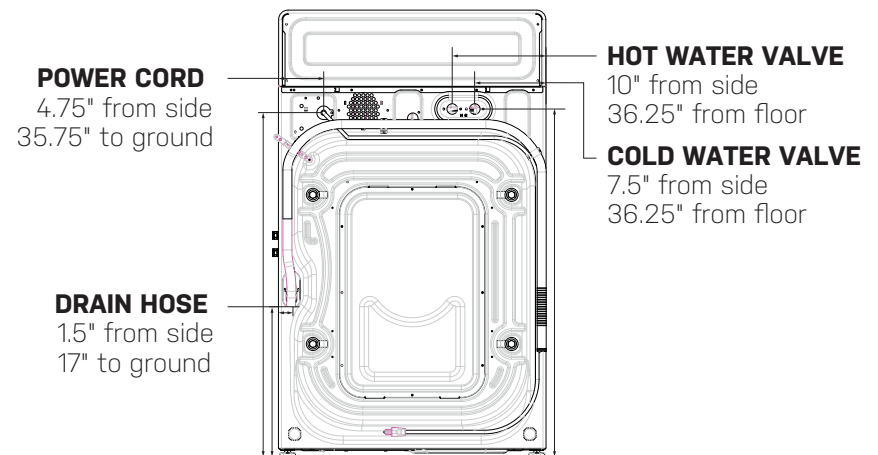

**POWER CORD**  
4.75" from side  
35.75" to ground

**HOT WATER VALVE**  
10" from side  
36.25" from floor

**COLD WATER VALVE**  
7.5" from side  
36.25" from floor

**DRAIN HOSE**  
1.5" from side  
17" to ground

### BACK VIEW



\*For improved performance, a 1/2" clearance is suggested on each side.

\*\*Accessories sold separately. For answers to your Monogram, Café™, GE Profile™ or GE Appliances product questions, visit our website at [geappliances.com](http://geappliances.com) or call GE Answer Center® Service, 800.626.2000.

# PFQ83HSHWWW

## GE Profile™ 4.6 cu. ft. Capacity UltraFast Combo with SmartDispense™ Technology Washer/Dryer

### FEATURES AND BENEFITS

**2-in-1 Washer/Dryer** – Wash & Dry a large load of laundry in about 2 hours without the hassle of transferring clothes from the washer to the dryer.\*

**SmartDispense™ Technology** – Save time and make laundry effortless with our intelligent dispenser that holds up to 32 loads of detergent and automatically dispenses the perfect amount based on load weight and fabric type for optimal cleaning performance.

**Fast Airflow Drying System** – Warm, high-speed air extracts moisture from garments to gently dry even large loads fast with less heat. Now you can wash and dry everything from a comforter to delicate items from start to finish virtually eliminating the need to hang dry- it's the ultimate one-and-done laundry experience!

**Easy Installation & Space-Saving Solutions** – Reimagine your laundry space and location with the flexible installation requirements of a standard 120V and no need for a dryer exhaust vent. The Ventless Combo design takes up half the space so you can rethink your laundry room possibilities.

**Greater Energy Savings\*\*** – 50% more energy efficient drying\*\* with Ventless Heat Pump.

**The One and Done Laundry Experience** – The UltraFast Combo is designed to enhance the way you experience laundry by optimizing washing + drying all in one machine. Plus, the smarter drying technology combines fast air flow at lower temperatures to ensure maximum care for all your laundry..

**Microban® Antimicrobial Technology** – Provides antimicrobial protection on the gasket, dispenser, and draining system to help prevent odors and ensure your Combo stays fresh and clean load after load.

**Smart Features Powered by SmartHQ™** – When connected to the SmartHQ™ app, you can make sure your Combo always has the latest features! Plus, remotely control and monitor as well as receive status notifications.

**Large Wash Capacity** – 4.6 cu.ft. capacity lets you clean large-sized loads- even clean a king-size comforter. Large wash capacity allows families of all sizes to cut laundry routine in half.

**Limited Warranty** – Rest assured knowing your unit is backed by a 10-year limited warranty on the motor and a 5-year limited warranty on the sealed drying system.

**EZ Access Lint Filter System** – An exclusive, easy-to-reach lint filter system allows you to remove lint and micro particles, ensuring your Combo operates at the highest levels of efficiency.

**Sanitize with Oxi** – Remove 99% of bacteria with a dedicated cycle that uses an Oxi additive to boost your detergent's cleaning power, while keeping fabrics looking and feeling their best.

**My Setting** – Store preferred wash and dry cycle settings for later use, maximize time and alleviate adjusting cycle preferences with every load. Cycle preferences are stored, selected and deselected with a touch of a button; a heart symbol appears to indicate the setting has been stored and in-use.

**Wrinkle Care** – Prevents wrinkles by extending the tumble without heat.

**Specialty Cycles** – Includes DeWrinkle, Air Fluff, EcoCool, Jeans, Power Clean, Self Clean, Swim Wear.

**ADA Compliant** – Easily reach the controls and operating mechanisms of this unit thanks to an accessible, front loading, ADA-compliant washer and dryer combo design.



\*Based on completing the Normal Wash + Dry cycle with Eco Dry on using a 10-lb. DOE or Mixed Load in about 2 hours. See Use & Care Manual for details.

\*\*Efficiency rating as compared to the requirements for ENERGY STAR qualification for standard electric dryers. For answers to your Monogram, Café™, GE Profile™ or GE Appliances product questions, visit our website at [geappliances.com](http://geappliances.com) or call GE Answer Center® Service, 800.626.2000.



Specification Revised 5/24