

get started

INSTANT POT® **DUO™ PLUS**

Instant®

IMPORTANT SAFEGUARDS



At Instant Brands™ your safety always comes first. The Instant Pot® Duo™ Plus was designed with your safety in mind, and we mean business. Check out this Instant Pot's long list of **safety mechanisms** to see what we mean.

As always, be careful when using electrical appliances and follow basic safety precautions.

- 01** READ ALL INSTRUCTIONS, SAFEGUARDS AND WARNINGS BEFORE USE. FAILURE TO FOLLOW THESE SAFEGUARDS AND INSTRUCTIONS MAY RESULT IN INJURY AND/OR PROPERTY DAMAGE.
- 02** Use only the Instant Pot Duo Plus lid with the Instant Pot Duo Plus multicooker base. Using any other pressure cooker lids may cause injury and/or damage.
- 03** For household use only. Not for commercial use. DO NOT use the appliance for anything other than its intended use.
- 04** For countertop use only. Always operate the appliance on a stable, non-combustible, level surface.
 - DO NOT place on anything that may block the vents on the bottom of the appliance.
 - DO NOT place on a hot stove.
- 05** Heat from an external source will damage the appliance.
 - DO NOT place the appliance on or close to a hot gas or electric burner, or a heated oven.
 - DO NOT use the appliance near water or flame.
 - DO NOT use outdoors. Keep out of direct sunlight.
- 06** DO NOT touch the appliance's hot surfaces. Only use the side handles for carrying or moving.
 - DO NOT move the appliance when it is under pressure.
 - DO NOT touch accessories during or immediately after cooking.
 - DO NOT touch the metal portion of the lid when the appliance is in operation; this could result in injury.
 - Always use hand protection when removing accessories, and to handle the inner pot.

▲ WARNING

Read this manual carefully and completely and retain for future reference. Failure to adhere to safety instructions may result in serious injury or damage.

IMPORTANT SAFEGUARDS



- Always place hot accessories on a heat-resistant surface or cooking plate.
- 07** The removable inner pot can be extremely heavy when full of ingredients. Care should be taken when lifting the inner pot from the multicooker base to avoid burn injury.
- Extreme caution must be used when the inner pot contains hot food, hot oil or other hot liquids.
 - DO NOT move the appliance while it is in use and use extreme caution when disposing of hot grease.
- 08** **⚠ CAUTION** Overfilling may cause a risk of clogging the steam release pipe and developing pressure, which may result in burns, injury, and/or property damage.
- DO NOT fill over **PC MAX — 2/3** as indicated on the inner pot.
 - DO NOT fill the inner pot over — **1/2** line when cooking foods that expand during cooking such as rice or dried vegetables.
- 09** **⚠ WARNING** This appliance cooks under pressure. Any pressure in the appliance can be hazardous. Allow the appliance to depressurize naturally or release all excess pressure before opening. Inappropriate use may result in burns, injury and/or property damage.
- Make sure the appliance is properly closed before operating. Refer to **Pressure control features: pressure cooking lid**.
 - DO NOT cover or obstruct the steam release valve and/or float valve with cloth or other objects.
 - DO NOT attempt to open the appliance until it has depressurized, and all internal pressure has been released. Attempting to open the appliance while it is still pressurized may lead to sudden release of hot contents and may cause burns or other injuries.
 - DO NOT place your face, hands or exposed skin over the steam release valve or float valve when the appliance is in operation or has residual pressure, and do not lean over the appliance when removing the lid.
 - Turn the appliance off if steam escapes from the steam release valve and/or float valve in a steady stream for longer than 3 minutes.

⚠ WARNING

Read this manual carefully and completely and retain for future reference.
Failure to adhere to safety instructions may result in serious injury or damage.

IMPORTANT SAFEGUARDS



- If steam escapes from the sides of the lid, turn the appliance off and make sure the sealing ring is properly installed. Refer to **Pressure control features: sealing ring**.
 - DO NOT attempt to force the lid off the Instant Pot multicooker base. Refer to **Releasing pressure**.
- 10 When cooking meat with skin (e.g. sausage with casing), the skin can swell when heated. Do not pierce the skin while it is swollen; this could result in scalding injury.
 - 11 When pressure cooking food with a doughy or thick texture, or a high fat/oil content, contents may splatter when opening the lid. Follow recipe instructions for pressure release method. Refer to **Releasing pressure**.
 - 12 Oversized foods and/or metal utensils must not be inserted into the inner pot as they may cause risk of fire and/or personal injury.
 - 13 Proper maintenance is recommended before and after each use:
 - Check the steam release valve, steam release pipe, anti-block shield and float valve for clogging;
 - Before inserting the inner pot into the multicooker base, make sure both parts are dry and free of food debris;
 - Let the appliance cool to room temperature before cleaning or storage.
 - 14 DO NOT use this appliance for deep frying or pressure frying with oil.
 - 15 If the power cord is detachable, always attach the plug to the appliance first, then plug the cord into the wall outlet. To turn off, press **Cancel**, then remove the plug from power source. Always unplug when not in use, as well as before adding or removing parts or accessories, and before cleaning. To unplug, grasp the plug and pull from the outlet. Never pull from the power cord.
 - 16 Regularly inspect the appliance and power cord. Do not operate the appliance if the power cord or plug is damaged, or after the appliance malfunctions or is dropped or damaged in any manner. For assistance, contact Customer Care by email at support@instanhome.com or by phone at **1-800-828-7280**.

WARNING

Read this manual carefully and completely and retain for future reference.
Failure to adhere to safety instructions may result in serious injury or damage.

IMPORTANT SAFEGUARDS



- 17 Spilled food can cause serious burns. A short power-supply cord is provided to reduce the hazards resulting from grabbing, entanglement and tripping.
 - DO NOT let the power cord hang over edges of tables or counters, or touch hot surfaces or open flame, including the stovetop.
 - DO NOT use below-counter power outlets, and never use with an extension cord.
 - Keep the appliance and cord away from children.
- 18 DO NOT use any accessories or attachments not authorized by Instant Brands Inc. The use of parts, accessories or attachments not recommended by the manufacturer may cause a risk of injury, fire or electric shock.
 - To reduce the risk of pressure leakage, cook only in an authorized stainless-steel Instant Pot inner pot.
 - DO NOT use the appliance without the removable inner pot installed.
 - To prevent personal injury and damage to the appliance, only replace the sealing ring with an authorized Instant Pot sealing ring.
- 19 DO NOT attempt to repair, replace or modify components of the appliance, as this may cause electric shock, fire or injury, and will void the warranty.
- 20 DO NOT tamper with any of the safety mechanisms, as this may result in injury or property damage.
- 21 The multicooker base contains electrical components. To avoid electrical shock:
 - DO NOT put liquid of any kind into multicooker base.
 - DO NOT immerse power cord, plug or the appliance in water or other liquid.
 - DO NOT rinse the appliance under tap.
- 22 DO NOT use the appliance in electrical systems other than 120 V~ 60 Hz for North America. Do not use with power converters or adapters.

▲ WARNING

Read this manual carefully and completely and retain for future reference.
Failure to adhere to safety instructions may result in serious injury or damage.

IMPORTANT SAFEGUARDS



- 23 This appliance is NOT to be used by children or by persons with reduced physical, sensory or mental capabilities. Close supervision is necessary when any appliance is used near children and these individuals. Children should not play with this appliance.
- 24 DO NOT leave the appliance unattended while in use. Never connect this appliance to an external timer switch or separate remote-control system.
- 25 DO NOT store any materials in the multicooker base or inner pot when not in use.
- 26 DO NOT place any combustible materials in the multicooker base or inner pot, such as paper, cardboard, plastic, Styrofoam or wood.
- 27 DO NOT use the included accessories in a microwave, toaster oven, convection or conventional oven, or on a ceramic cooktop, electric coil, gas range or outdoor grill.

SAVE THESE INSTRUCTIONS.

▲ WARNING

To avoid injury, read and understand the instructions in this user manual before attempting to use this appliance.

▲ WARNING

Electrical shock hazard. Use grounded outlet only.

- DO NOT remove ground.
- DO NOT use an adapter.
- DO NOT use an extension cord.

Failure to follow these instructions may result in electric shock and/or serious injury.

▲ WARNING

THE FAILURE TO FOLLOW ANY OF THE IMPORTANT SAFEGUARDS AND/OR THE INSTRUCTIONS FOR SAFE USE IS A MISUSE OF YOUR APPLIANCE THAT CAN VOID YOUR WARRANTY AND CREATE THE RISK OF SERIOUS INJURY.

▲ WARNING

Read this manual carefully and completely and retain for future reference. Failure to adhere to safety instructions may result in serious injury or damage.

IMPORTANT SAFEGUARDS









Special cord set instructions

Per safety requirement, a short power supply cord is provided to reduce the hazards resulting from entanglement and tripping.

This appliance has a 3-prong grounding plug. To reduce the risk of electric shock, plug the power cord into a grounded electrical outlet that is easily accessible.

Product specifications

To view a full list of sizes, colors and patterns, go to instanthome.com.

					
Duo Plus 3 v3	700 W	120 V~ 60 Hz	2.8 Litres / 3 Quart	4.10 kg / 9.00 lbs	cm: 29 L x 25.5 W x 28.5 H in: 11.42 L x 10.04 W x 11.22 H
Duo Plus 6 v3	1 000 W	120 V~ 60 Hz	5,7 litres / 6 pintes	5.50 kg / 12.10 lb	cm: 33 L x 31 L x 32 H in : 12.99 L x 12.20 L x 12.60 H
Duo Plus 8 v3	1 200 W	120 V~ 60 Hz	7,6 litres / 8 pintes	7.30 kg / 16.09 lb	cm : 37.7 L x 33.8 L x 36.1 H in : 14.84 L x 13.31 L x 14.21 H

Find your model name and serial number

Model name: Find it on the label on the back of the multicooker base, near the power cord.

Serial number: Turn the multicooker base over – you'll find this info on a sticker on the bottom.

WARNING

Read this manual carefully and completely and retain for future reference.
Failure to adhere to safety instructions may result in serious injury or damage.

Product, parts and accessories

See **Care, cleaning and storage: Removing and installing parts** to find out how everything fits together.

Top of lid

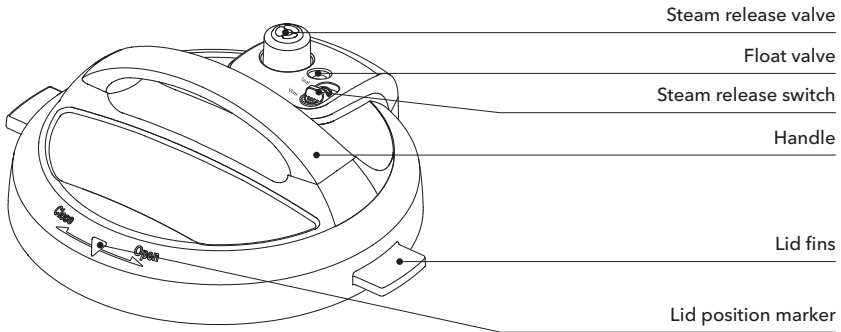

Bottom of lid

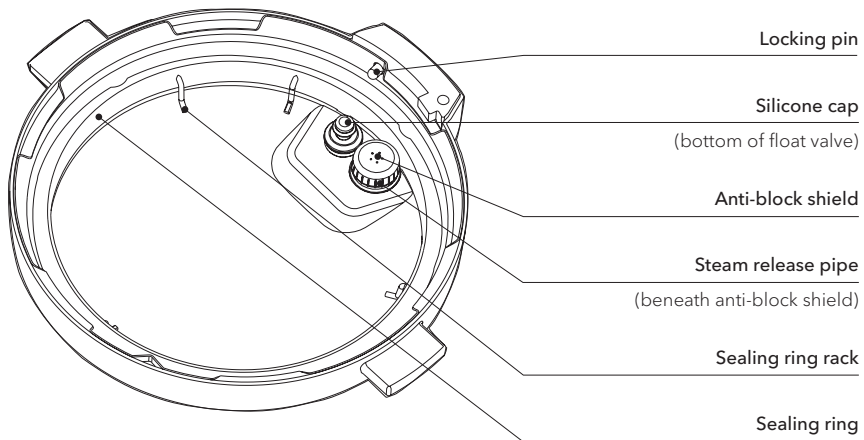

Instant Tip: Stand the lid up in the base handles to keep it off your countertop! Insert the left or right lid fin into corresponding slot in the multicooker base handles to stand it up and save some space.

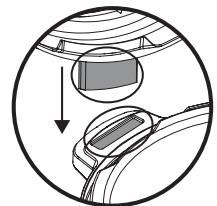

Illustrations in this document are for reference only and may differ from the actual product. Always refer to the actual product.

Product, parts and accessories

Inner pot

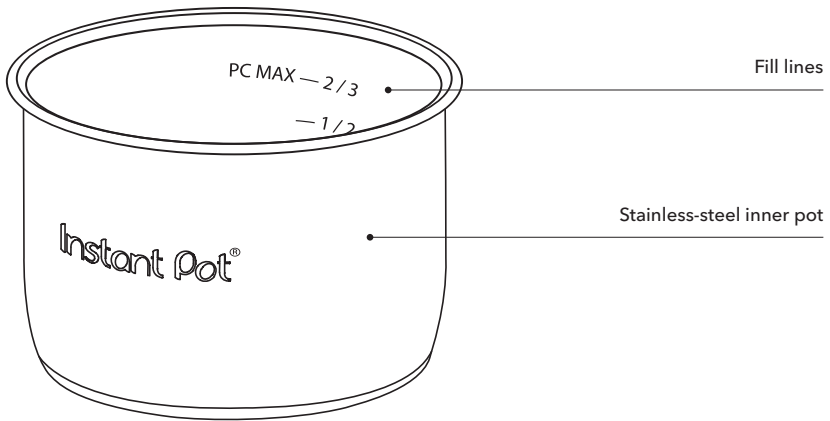

Multicooker base

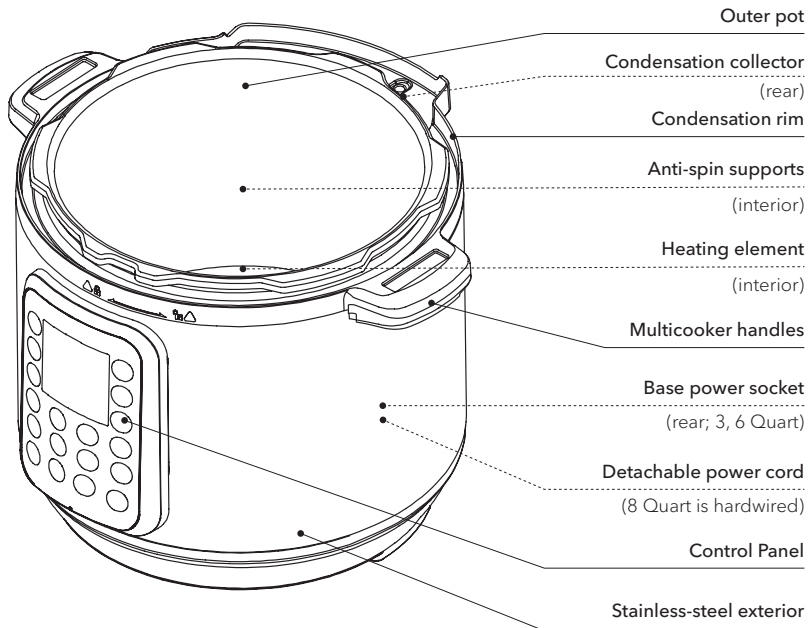

Illustrations in this document are for reference only and may differ from the actual product. Always refer to the actual product.

Get started



Initial set up

You – yes, you – can do this!



“Once you have mastered a technique, you barely have to look at a recipe again!”

- Julia Child

- 01** Pull that Duo Plus out of the box!
- 02** Remove the packaging material and accessories from in and around the multicooker.
-  **03** Make sure to check under the inner pot!
- 03** Wash the inner pot in a dishwasher or with hot water and dish soap. Rinse it well with warm, clear water and use a soft cloth to thoroughly dry the outside of the inner pot.
- 04** Wipe the heating element with a soft, dry cloth to make sure there are no stray packaging particles left in the multicooker base.
-  **04** Don't remove the safety warning stickers from the lid or the rating label from the back of the multicooker base.
- 05** You may be tempted to put the Instant Pot on your stovetop – *but don't do it!*
Place the multicooker base on a stable, level surface, *away* from combustible material and external heat sources.

Is something missing or damaged?

Get in touch with a Customer Care Advisor by email at support@instanthome.com or by phone at **1-800-828-7280** and we'll happily make some magic happen for you!

Feeling keen?

- Check out **Product, parts and accessories** to get to know your Instant Pot's components, then read over **Pressure control features** for an in-depth look.
- While you're doing the **Initial test run (water test)**, read over **Pressure cooking 101** to find out how the magic happens!

WARNING

Read the **Important safeguards** before using the appliance. Failure to read and follow those instructions for safe use may result in damage to the appliance, personal injury and/or property damage.

Do not place the appliance on a stovetop or upon another appliance. Heat from an external source will damage the appliance.

Do not place anything on top of the appliance, and do not cover or block the steam release valve or anti-block shield, located on the appliance lid to avoid risk of injury and/or property damage.

Get started

Initial test run (water test)

Do you *have* to do the water test? No – but getting to know the ins and outs of your Duo Plus prepares you for success in the kitchen! Take a few minutes to get to know how this baby works.

Stage 1: Setting up the Duo Plus for pressure cooking

01 Remove the inner pot from the multicooker base and add 3 cups (750 mL / ~25 oz) of water to the inner pot. Insert it back into the multicooker base.

02 **3 quart and 6 quart:** Secure the power cord to the base power socket on the back of the multicooker base. Make sure the connection is tight.

All sizes: Connect the power cord to a 120 V power source.

The display shows **OFF**.

03 Place and close the lid as described in **Pressure control features: Pressure cooking lid**.

Stage 2: "Cooking" (...but not really, this is just a test!)

01 Select **Pressure Cook**.

02 Use the **- / + Time** buttons to adjust the cooking time to 5 minutes (**00:05**).

 Adjustments are saved when a Smart Program starts, so the next time you use Pressure Cook, it will default to 5 minutes.

03 Press **Keep Warm** to turn the automatic Keep Warm setting off.

04 Press **Start** to begin. The display shows **On**.

 While the multicooker does its thing, read **Pressure cooking 101** on the next page to find out how the magic happens.

05 When the Smart Program finishes, the display shows **End**.

Stage 3: Releasing pressure

01 Follow instructions for a Quick Release in **Releasing pressure: Venting methods**.

02 Wait for the float valve to drop, then carefully open and remove the lid as described in **Pressure control features: Pressure cooking lid**.

03 Using proper hand protection, remove the inner pot from the multicooker base, discard the water and thoroughly dry the inner pot.

That's it! You're good to go :)

CAUTION

Pressurized steam releases through the top of the steam release valve. Keep exposed skin away from the steam release valve to avoid injury.

DANGER

DO NOT attempt to remove the lid while the float valve is up and NEVER attempt to force the lid open. Contents are under extreme pressure. Float valve must be down before attempting to remove the lid. Failure to follow these instructions may result in serious personal injury and/or property damage.

CAUTION

The inner pot will be hot after cooking. Always use appropriate heat protection when handling a hot inner pot to avoid injury.

Pressure cooking 101

Pressure cooking uses steam to raise the boiling point of water above 100°C / 212°F. These high temperatures allow you to cook some foods way faster than normal.

When pressure cooking, the Instant Pot goes through 3 stages.

Pre-heating

What you see	What you don't see	Tips
The display shows On .	While the multicooker pre-heats, it vaporizes liquid to create steam. Once enough steam has built up, the float valve pops up and locks the lid in place.	The time it takes the multicooker to pressurize depends on things like food and liquid temperature and volume. Frozen foods have the longest pre-heating time. For the fastest results, thaw your food before cooking it. While you're waiting, read over Releasing pressure for information on safe venting techniques.

Cooking

What you see	What you don't see	Tips
The float valve may release a bit of steam before it pops up and seals the multicooker. The display switches to the cooking countdown timer.	When the multicooker reaches the required pressure level, cooking begins. The Instant Pot automatically maintains High or Low pressure throughout cooking.	A higher pressure means a higher temperature. Smart Program settings (e.g., cooking time, pressure level, etc.) can be adjusted at any time during cooking.

Releasing pressure

What you see	What you don't see	Tips
If Keep Warm is on after cooking, the timer counts up from 00:00 . If not, the multicooker goes back to standby and the display shows End . The float valve is still popped up.	Although food has finished cooking, the multicooker is still pressurized and hot, which is why the float valve is up. Releasing pressure lowers the temperature inside the multicooker, which allows you to safely remove the lid once the float valve drops.	See Releasing pressure for information on safe venting techniques and what they're used for. Follow your recipe instructions to choose the best venting method for your meal.  Instant Tip: The Instant Pot cools faster if Keep Warm is turned off.

Releasing pressure

You **must** release pressure after pressure cooking before attempting to open the lid. Follow your recipe's instructions to choose a venting method, and always wait until the float valve drops into the lid before opening.

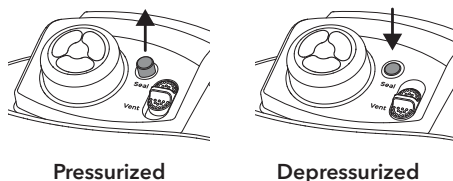

⚠ WARNING	
<p>Steam ejected from the steam release valve is hot. DO NOT place hands, face, or any exposed skin over the steam release valve when releasing pressure to avoid risk of injury.</p>	<p>DO NOT cover the steam release valve to avoid risk of injury and/or property damage.</p>

⚠ DANGER
<p>DO NOT attempt to remove the lid while the float valve is up and NEVER attempt to force the lid open. Contents are under extreme pressure. Float valve must be down before attempting to remove the lid. Failure to follow these instructions may result in serious personal injury and/or property damage.</p>

Venting methods

- Natural Release (NR or NPR)
- Quick Release (QR or QPR)
- Timed Natural Release

Natural Release (NR or NPR)

Cooking stops gradually. As the temperature within the multicooker drops, the Instant Pot depressurizes naturally over time.



What to do	What to expect
<p>After cooking finishes, leave the quick release switch in the Seal position until the float valve drops into the lid.</p> <div style="text-align: center;"> <p>Seal position</p> </div>	<p>Your meal continues to cook even after the Smart Program ends.</p> <p> Instant Tip: This is called "carryover cooking" or "resting", and it's great for large cuts of meat.</p> <p>The depressurization time may vary based upon the volume, type and temperature of food and liquid. It can take up to 40 minutes with some dishes, so plan ahead – it's well worth the wait!</p> <p>When pressure has been fully released, the float valve drops into the lid.</p>

NOTICE
<p>Use NR to depressurize the multicooker after cooking high-starch foods (e.g., soups, stews, chilis, pasta, oatmeal and congee) or after cooking foods that expand when cooked (e.g., beans and grains).</p>

Releasing pressure

Quick Release (QR or QPR)

Stops cooking quickly and prevents overcooking. Perfect for quick-cooking vegetables and delicate seafood!

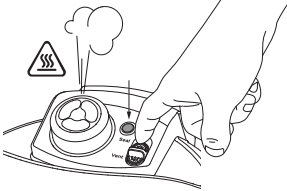
What to do	What to expect
<p>Move the quick release switch from Seal to Vent and wait until the float valve drops into the lid.</p> <div style="display: flex; justify-content: space-around; align-items: center;"> <div style="text-align: center;">  <p>Seal position</p> </div> <div style="text-align: center;">  <p>Vent position</p> </div> </div>	<p>A jet of steam ejects through the top of the steam release valve.</p> <p>This is normal!</p> <p>When pressure has been fully released, the float valve drops into the lid.</p> 

If you see a lot of spatter while releasing pressure, move the quick release switch back from **Vent** to **Seal**, and wait a few minutes before trying to release pressure again. If spatter continues, use NR to safely release the remaining pressure.

Timed natural release

The carryover cooking continues for a specific amount of time, then stops quickly when you release the remaining pressure. Perfect for finishing rice and grains.

What to do	What to expect
<p>Leave the quick release switch in the Seal position for a few minutes (according to your recipe) then move it from Seal to Vent and wait until the float valve drops into the lid.</p>	<p>A jet of steam ejects through the top of the steam release valve.</p> <p> The temperature within the multicooker drops, so the steam release may not be as powerful as a normal QR.</p> <p>When pressure has been fully released, the float valve drops into the lid.</p>

⚠ CAUTION

Steam ejected from the steam release valve is hot. **DO NOT** place hands, face, or any exposed skin over the steam release valve when releasing pressure to avoid injury.

NOTICE

Do not use QR when cooking fatty, oily, thick or high-starch foods (e.g., stews, chilis, pasta and congee) or when cooking foods that expand when cooked (e.g., beans and grains).

Control panel

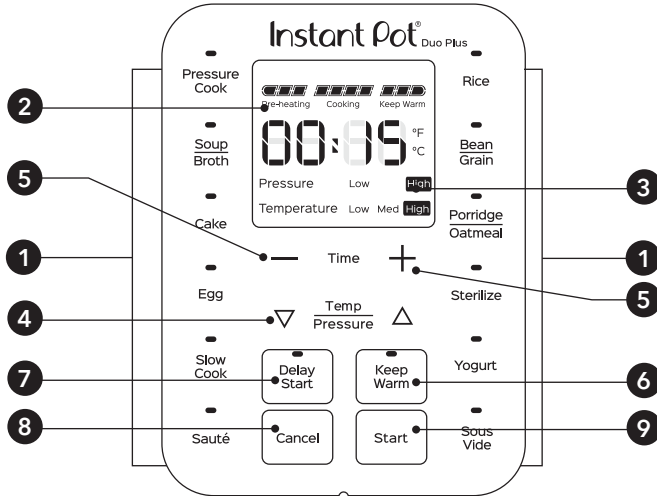

1	Smart Programs	Pressure cooking <ul style="list-style-type: none"> • Pressure Cook • Soup/Broth • Cake • Egg • Rice • Bean/Grain • Porridge/Oatmeal • Sterilize 	Non-pressure cooking <ul style="list-style-type: none"> • Slow Cook • Sauté • Yogurt • Sous Vide
2	Time display	Shows the time in HH:MM format. Counts up or down, depending on the Smart Program.  Also displays temperature in °C (Celsius) or °F (Fahrenheit) during Sous Vide.	
3	Pressure	Shows Low or High pressure during pressure cooking.	
	Temperature	Shows when the multicooker is using Low, Med or High temperature.	
4	Temp / Pressure buttons	Toggles between temperature and pressure levels.	
5	- / + Time buttons	Adjusts time for cooking, Delay Start and Keep Warm.	
6	Keep Warm	Turns the Keep Warm setting on or off.	
7	Delay Start	Delays the start of cooking.	
8	Cancel	Stops a Smart Program at any time.	
9	Start	Begins the selected Smart Program.	

View the full user manual online at instantpot.com/duoplus for more information.

Status messages

OFF	The Instant Pot is in standby mode, ready for action!
Lid	May indicate that the lid is missing or is not properly secured.
On	The multicooker is Pre-heating .
boil	The Yogurt Smart Program is in the process of pasteurizing milk (i.e., the Yogurt Smart Program is set to More).
Hot	The Sauté or Sous Vide Smart Program has reached the ideal cooking temperature and food may be added to the inner pot.
00:00	<p>Display shows one of the following:</p> <ul style="list-style-type: none"> • When a Smart Program is running, the timer counts down the remaining cooking time; • When Delay Start is running, the timer counts down until the Smart Program begins; • When Keep Warm is running, the timer counts the length of time that food has been warming.
End	The Smart Program has finished and Keep Warm is off.
Food burn	The multicooker may be overheating due to insufficient liquid. See the Troubleshooting section in the full user manual online at instantpot.com/duoplus .

Do you see something else? See the Troubleshooting section in the full user manual online at instantpot.com/duoplus.

Pressure control features

See **Care, cleaning and storage** for installation and removal of parts.

Pressure cooking lid

What we love about it	What you should know about it
<p>When you close it, it sets to Seal automatically, for seriously easy pressure cooking.</p> <p>While plugged in, the Duo Plus plays a little jingle when you open and close the lid.</p>	<p>The lid is removable during non-pressure cooking so you can taste-test as you go.</p> <p>When you're pressure cooking, the lid only locks into place once the multicooker has pressurized. Try not to remove the lid unnecessarily!</p>

Removing the lid

- 01** Grip the lid handle and turn it counter-clockwise to align the symbol on the lid ▼ with the symbol on the rim of the multicooker base ⚙▲.
- 02** Lift the lid up and off the multicooker base towards your body.

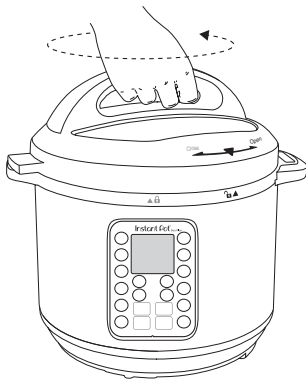

Closing the lid

- 01** Align the symbol on the lid ▼ with the symbol on the multicooker base ⚙▲, then lower the lid onto the track.
- 02** Turn the lid clockwise until the symbol on the lid ▼ aligns with the symbol on the multicooker base ⚙▲.

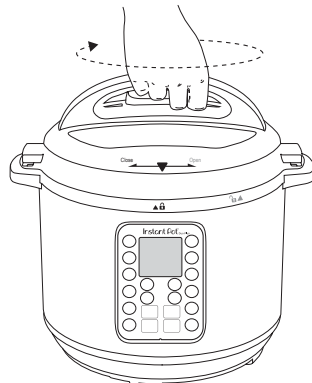

Illustrations in this document are for reference only and may differ from the actual product. Always refer to the actual product.

⚠ WARNING

Only use a compatible Instant Pot Duo Plus lid with the Instant Pot Duo Plus multicooker base. Using any other pressure cooker lids may cause injury and/or damage.

⚠ CAUTION

Always check the lid for damage and excessive wear prior to cooking to avoid risk of injury and/or property damage.

Pressure control features

Quick release switch

The quick release switch controls the steam release valve – the part that releases pressure.

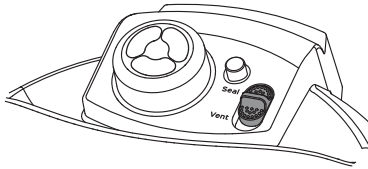

Seal position

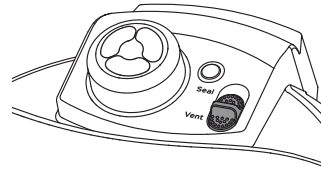

Vent position

What we love about it	What we should know about it
It's <i>super</i> easy to use, and keeps our hands far away from the steam when the multicooker is releasing pressure!	It automatically sets to Seal when you close the lid, so make sure to move it to Vent when you're not pressure cooking.

See **Releasing pressure: Venting methods** for safe depressurization techniques.

Steam release valve

The steam release valve sits loosely on the steam release pipe.

When the multicooker releases pressure, steam ejects from the top of the steam release valve. The steam release valve is integral to product safety and necessary for pressure cooking.

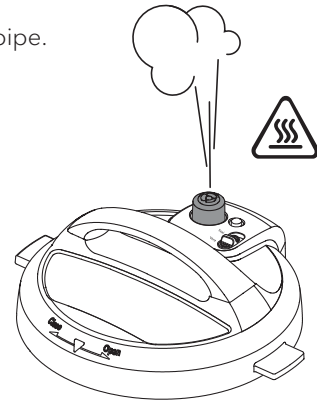

⚠ WARNING
Do not cover or block the steam release valve in any way to avoid risk of personal injury and/or property damage.

Pressure control features

Sealing ring

When the pressure cooking lid is closed, the sealing ring creates an air-tight seal between the lid and the inner pot.

The sealing ring must be installed before using the multicooker. Only one sealing ring should be installed in the lid at a time.

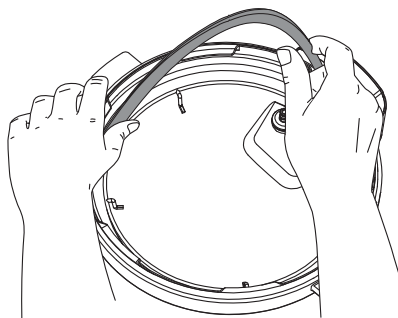

 **Instant Tip:** Silicone is porous, so it absorbs strong aromas and certain flavors. Keep extra sealing rings on hand to limit the transfer of aromas and flavors between dishes.

⚠ CAUTION

Only use authorized Instant Pot sealing rings. **DO NOT** use a stretched or damaged sealing ring.

- Always check for cuts, deformation and correct installation of the sealing ring before cooking.
- Sealing rings stretch over time with normal use. The sealing ring should be replaced every 12 to 18 months or sooner if you notice stretching, deformation, or damage.

Failure to follow these instructions may cause food to discharge, which may lead to personal injury and/or property damage.

Anti-block shield

The anti-block shield prevents food particles from coming up through the steam release pipe, assisting with pressure regulation.

The anti-block shield is integral to product safety and necessary for pressure cooking.

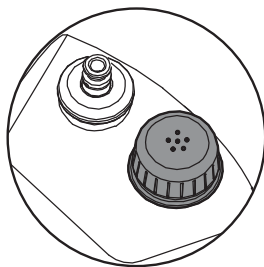

Pressure control features

Float valve

The float valve is a visual indication of whether there is pressure in the multicooker (pressurized) or not (depressurized). It appears in two positions:

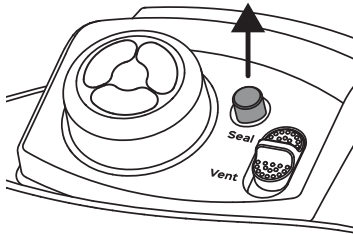

Pressurized

The float valve has visibly popped up above the surface of the lid.

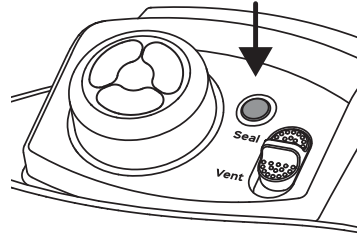

Depressurized

The float valve has descended, and the top is flush with the lid.

The float valve and silicone cap work together to seal in pressurized steam. These parts must be installed before use. Do not attempt to operate the Instant Pot without the float valve properly installed. **Do not touch the float valve during use.**

Illustrations in this document are for reference only and may differ from the actual product. Always refer to the actual product.

⚠ DANGER

DO NOT attempt to remove the lid while the float valve is up and NEVER attempt to force the lid open. Contents are under extreme pressure. Float valve must be down before attempting to remove the lid. Failure to follow these instructions may result in serious personal injury and/or property damage.

Pressure cooking

Whether you're a whiz in the kitchen or a complete newbie, these Smart Programs help get you cooking with the touch of a button.

- Pressure Cook
- Soup/Broth
- Cake
- Egg
- Rice
- Bean/Grain
- Porridge/Oatmeal
- Sterilize

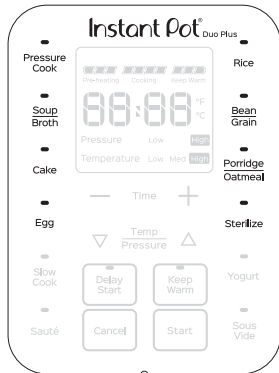

Using pressurized steam guarantees your dish is cooked evenly and deeply, for the delicious results you expect every time.

Pressure level	Suggested use	Notes
Low Pressure 5.1 - 8 psi (35 - 55 kPa)	Fish and seafood, soft vegetables and rice.	The pressure level controls the temperature, so a higher pressure results in a higher cooking temperature.
High Pressure 9.4 - 12.3 psi (65 - 85 kPa)	Eggs, meat, poultry, root vegetables, oats, beans, grains, bone broth, stew, chili.	



Instant Tip: Use the steam rack to keep foods out of the cooking liquid. This helps to distribute heat, prevents nutrients from leaching into the cooking liquid, and, stops food items from sticking to the bottom of the inner pot.

⚠ WARNING

Always cook with the inner pot in place. Food must be placed in the inner pot. **DO NOT pour food or liquid into the multicooker base.**

To avoid risk of personal injury and/or property damage, place food and liquid ingredients in the inner pot, then insert the inner pot into the multicooker base.

Do not fill inner pot higher than the **PC MAX — 2/3** (Pressure Cooking Maximum) line as indicated on the inner pot.

When cooking foods that **foam or froth** (e.g., applesauce, cranberries or split peas) or **expand** (e.g., oats, rice, beans, pasta) do not fill the inner pot higher than the **— 1/2** line as indicated on the inner pot.

⚠ CAUTION

Always inspect the lid and inner pot carefully to make sure they are clean and in good working condition before use.

- To avoid personal injury or damage to the appliance, replace the inner pot if it is dented, deformed or damaged.
- Use only authorized Instant Pot inner pots made for this model when cooking.

Always make sure the inner pot and heating element are clean and dry before inserting the inner pot into the multicooker base.

Failure to follow these instructions may damage the multicooker. Replace damaged parts to ensure safe function.

Pressure cooking

To create steam, pressure cooking liquids should be water-based, such as broth, stock, soup or juice. If using canned, condensed or cream-based soup, add water as directed below.

Instant pot size	Minimum liquid for pressure cooking
2.8 Litres / 3 Quarts	1 cup (1 cup (250 mL / ~8 oz))
5.7 Litres / 6 Quarts	1½ cup (375 mL / ~12 oz)
7.6 Litres / 8 Quarts	2 cups (500 mL / ~16 oz)

⚠ CAUTION

To avoid scorching or scalding injury, be cautious when cooking with more than 1/4 cup (60 mL / ~2 oz) oil, oil-based sauces, condensed cream-based soups, and thick sauces. Add suitable liquid to thin sauces. Avoid recipes that call for more than 1/4 cup (60 mL / ~2 oz) of oil or fat content.

**Unless otherwise specified by your recipe.*

To get pressure cooking, follow the same basic steps as you did in the Initial test run (water test) – but add food this time!



Using the multi-functional rack ensures your food items are steamed and not boiled. It helps to heat food evenly, prevents nutrients from leeching into the cooking liquid, and stops food items from scorching on the bottom of the inner pot.

When the Smart Program finishes, follow your recipe's directions to select the appropriate venting method. See Releasing pressure: Venting methods for safe venting techniques.

Find full instructions for use in the user manual online at instantpot.com/duoplus.

Find tried and true recipes, as well as pressure cooking timetables under the Recipes tab at instantpot.com, and download the Instant Pot app from instantpot.com/app!

⚠ DANGER

DO NOT attempt to remove the lid while the float valve is up and NEVER attempt to force the lid open. Contents are under extreme pressure. Float valve must be down before attempting to remove the lid. Failure to follow these instructions may result in serious personal injury and/or property damage.

Pressure cooking

Smart program breakdown

Smart Programs	Default time	Time range	Default pressure level	Notes and tips
Pressure Cook	10 minutes (00:10)	1 minute to 8 hours (00:01 to 08:00)	High	Flexible manual programming.
Soup/Broth	30 minutes (00:30)	1 minute to 4 hours (00:01 to 04:00)	High	Liquid remains clear due to lack of boiling motion. Always use NR to release pressure when cooking soup with a high starch content.
Cake	30 minutes (00:30)	1 minute to 4 hours (00:01 to 04:00)	High	Adjust cook time as directed in recipe. Cake batter should be poured into a springform pan and covered with foil or an oven-safe lid. Leave 1" of space around the pan to ensure heat circulates properly.
Egg	5 minutes (00:05)	1 minute to 1 hour (00:01 to 01:00)	High	Preset times are intended for extra large eggs. Adjust cooking time to account for different sized eggs. Plunge eggs into ice bath to prevent overcooking.
Rice	12 minutes (00:12)	1 minute to 1 hour (00:01 to 01:00)	Low	For cooking medium and long-grain white rice. Use a 10-minute Natural Release after cooking for perfect results.
Bean/Grain	20 minutes (00:20)	1 minute to 1 hour (00:01 to 01:00)	High	When cooking beans or legumes, always use NR to release pressure. Make sure dry beans are completely submerged in water.
Porridge/Oatmeal	5 minutes (00:05)	1 minute to 1 hour (00:01 to 01:00)	High	Adjust time as directed in recipe. Always use NR to release pressure when cooking foods that expand.
Sterilize	15 minutes (00:15)	1 minute to 1 hour (00:01 to 01:00)	High	Sterilize utensils, tempered glass, and some heat-resistant plastics. Low and High pressure hot water bath canning of acidic fruits and vegetables.

Other cooking styles

The Duo Plus is much more than a pressure cooker. These Smart Programs don't cook with pressure, but are just as easy to use and give you delicious results.

- Slow Cook
- Sauté
- Yogurt
- Sous Vide

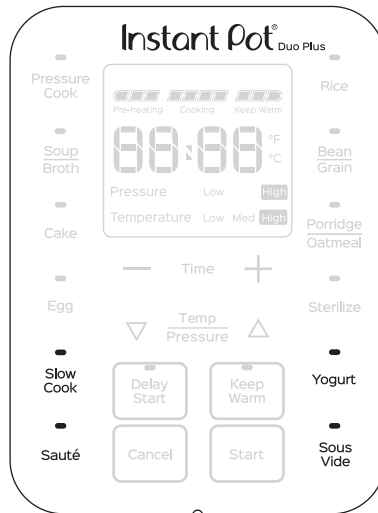

⚠ WARNING

Always cook with the inner pot in place. Food must be placed in the inner pot. **DO NOT pour food or liquid into the multicooker base.**

To avoid risk of personal injury and/or property damage, place food and liquid ingredients in the inner pot, then insert the inner pot into the multicooker base.

Do not fill inner pot higher than the **PC MAX — 2/3** (Pressure Cooking Maximum) line as indicated on the inner pot.

When cooking foods that **foam or froth** (e.g., applesauce, cranberries or split peas) or **expand** (e.g., oats, rice, beans, pasta) do not fill the inner pot higher than the **— 1/2** line as indicated on the inner pot.

⚠ CAUTION

Always inspect the lid and inner pot carefully to make sure they are clean and in good working condition before use.

- To avoid personal injury or damage to the appliance, replace the inner pot if it is dented, deformed or damaged.
- Use only authorized Instant Pot inner pots made for this model when cooking.

Always make sure the inner pot and heating element are clean and dry before inserting the inner pot into the multicooker base.

Failure to follow these instructions may damage the multicooker. Replace damaged parts to ensure safe function.

Other cooking styles

Slow Cook

Slow Cook is compatible for use with any common slow cooker recipe, so you can keep cooking your classics!

 If the float valve rises, make sure the quick release switch is set to **Vent**. See **Pressure control features: Quick release switch**.

Default time	Time range	Default temperature	Temperature range	Notes and tips
6 hours (06:00)	30 minutes to 24 hours (00:30 to 24:00)	Med	Low Med High	Less is commonly used for low and slow, all-day cooking, and should be set for a minimum of 10 hours (10:00) for best results. You can use a glass lid for slow cooking if it has a venting hole.

Sauté

Sauté can be used in place of a frying pan, griddle or flat-top grill.

Default time	Time range	Default temperature	Temperature range	Notes and tips
30 minutes (00:30)	1 minute to 1 hour (00:01 to 01:00)	High	Low	Simmering, thickening, and reducing liquids.
			Med	Pan searing or sautéing.
			High	Stir-frying or browning meat.

Find full instructions for use in the user manual online at instanthome.com

When pressure cooking after using Sauté, deglaze the inner pot to make sure food items do not scorch.

To deglaze: Remove food items from the inner pot and add a thin liquid (e.g., water, broth, wine) to the hot surface. Use a wooden or silicone scraper to loosen anything that may be stuck to the bottom of the inner pot.

WARNING

The Sauté Smart Program reaches high temperatures. If unmonitored, food may burn on this setting. Do not use the lid and do not leave your multicooker unattended while using Sauté.

Other cooking styles

Yogurt

Produce delicious fermented dairy and non-dairy recipes effortlessly.

Instant Pot Size	Minimum Milk Volume	Maximum Milk Volume
2.8 Litres / 3 Quarts	4 cups (1 L / ~32 oz)	~2.5 quarts (2.4 L / ~ 81 oz)
5.7 Litres / 6 Quarts	4 cups (1 L / ~32 oz)	~4 quarts (~3.8 L / ~128 oz)
7.6 Litres / 8 Quarts	6 cups (1.5 L / ~48 oz)	~6 quarts (~5.7 L / ~192 oz)

Default temperature	Temperature range	Default time	Time range	Notes and tips
High	Low	24 hours (24:00)	30 minutes to 99 hours and 30 minutes (00:30 to 99:30)	For lower temperature fermentation (e.g., Jiu niang, a sweet fermented glutinous rice dessert).
	Med	8 hours (08:00)	30 minutes to 99 hours and 30 minutes (00:30 to 99:30)	Fermenting milk after culture has been added.
	High	(boil)	Not adjustable.	Pasteurizing milk.

Find full instructions for use in the user manual online at [instanthome.com](https://www.instanthome.com)

Other cooking styles

Sous Vide

Sous Vide cooking involves cooking food underwater in an air-tight, food-safe bag, for a long period of time. Food cooks in its own juices and comes out delicious and unbelievably tender.

Default temperature	Temperature range	Default time	Time range	Notes and tips
56°C 133°F	25 to 90°C 77 to 194°F	3 hours (03:00)	30 minutes to 99 hours and 30 minutes (00:30 to 99:30)	Separating servings can help you accommodate unique dietary restrictions.

You'll need:

- Tongs
- Thermometer
- Food safe, airtight, re-sealable food pouches, or,
- Vacuum sealer and food-safe vacuum bags

Find full instructions for use in the user manual online at instantpot.com/duoplus.

For sous vide cooking guidelines, check out the Cooking Time Tables under the Recipes tab at instantpot.com.

⚠ CAUTION

Do not overfill the inner pot to avoid property damage. Total contents (water and food pouches) should leave at least 5 cm (2") of headspace between the water line and the brim of the inner pot.

⚠ CAUTION

When cooking meat, always use a meat thermometer to ensure the internal temperature reaches a safe minimum temperature. Refer to the USDA's **Safe Minimum Internal Temperature Chart** or Health Canada's **Cooking Temperatures Chart** for more information.

Care, cleaning and storage

Clean your Duo Plus and its parts after each use. Failure to follow these cleaning instructions may result in catastrophic failure, which may lead to property damage and/or severe personal injury.

Always unplug your multicooker and let it cool to room temperature before cleaning. Never use metal scouring pads, abrasive powders or harsh chemical detergents on any of the Instant Pot's parts or accessories.

Let all surfaces dry thoroughly before use, and before storage.

Parts	Cleaning methods and instruction
Accessories <ul style="list-style-type: none"> • Steam rack 	Dishwasher safe.
Lid and parts <ul style="list-style-type: none"> • Anti-block shield • Sealing rings • Steam release valve • Float valve • Silicone cap • Condensation collector 	Dishwasher safe if placed on the top rack. Remove all the parts from the lid before cleaning. See Care, cleaning and storage: Removing and installing parts. <ul style="list-style-type: none"> • With steam release valve and anti-block shield removed, clean the interior of the steam release pipe to prevent clogging. • To drain water from the lid after dishwashing, grasp the lid handle and hold the lid vertically over a sink, then turn it 360° – like turning a steering wheel. • After cleaning, store the lid upside down on the multicooker base. • Store sealing rings in a well-ventilated area to decrease residual odor of flavorful meals. To eliminate odors, add 1 cup (250 mL / ~8 oz) water and 1 cup (250 mL / ~8 oz) white vinegar to the inner pot, and run Pressure Cook for 5-10 minutes, then QR pressure. • Check the condensation collector after each use and empty as needed. Do not allow food or moisture to stagnate in the condensation collector.
Inner pot	Dishwasher safe. <ul style="list-style-type: none"> • More acute hard water staining may require a vinegar-dampened sponge and some scrubbing to remove. • If there is tough or burned food residue at the bottom, soak in hot water for a few hours for easy cleaning. • Make sure all exterior surfaces are dry before placing in the multicooker base.
Power cord	Hand wash only. Do not machine wash. <ul style="list-style-type: none"> • Use a barely damp cloth to wipe any particles off the cord.  3 and 6 quart has detachable cord for storage.
Multicooker base	Hand wash only. Do not machine wash. <ul style="list-style-type: none"> • Clean the multicooker base and control panel with a soft, barely damp cloth or sponge. • Wipe the inside of the cooker base, the heating element, and the condensation rim with a barely damp cloth. Allow them to dry completely before inserting the inner pot.

Some discoloration may occur after machine washing, but this will not affect the multicooker's safety or performance.

Care, cleaning and storage

⚠ WARNING

The Instant Pot multicooker base contains electrical components. To avoid fire, electric leakage or personal injury, make sure the multicooker base stays dry.

- DO NOT immerse the multicooker base in water or other liquid, or attempt to cycle it through the dishwasher.
- DO NOT rinse the heating element.
- DO NOT submerge or rinse the power cord or the plug.

Removing and installing parts

Silicone sealing ring

Remove the sealing ring

Grip the edge of the silicone and pull the sealing ring out from behind the circular stainless-steel sealing ring rack.

With the sealing ring removed, inspect the steel rack to make sure it is secured, centered, and at an even height all the way around the lid. Do not attempt to repair a deformed sealing ring rack.

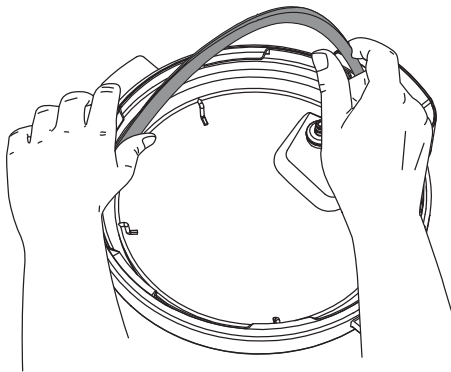

Install the sealing ring

Place the sealing ring over the sealing ring rack and press it into place. Press down firmly to prevent puckering.

When installed properly, the sealing ring is snug behind sealing ring rack and should not fall out when the lid is turned over.

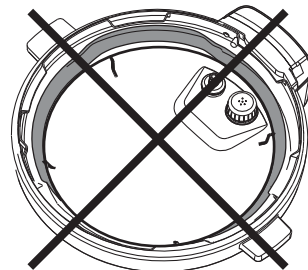
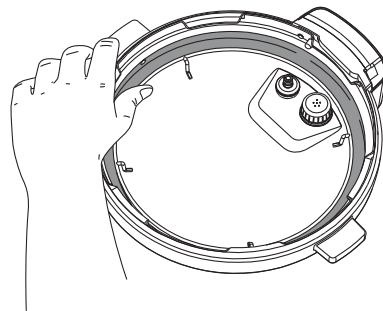

Incorrect

Illustrations in this document are for reference only and may differ from the actual product. Always refer to the actual product.

Care, cleaning and storage

Steam release valve

Remove the steam release valve

Pull the steam release valve up and off the steam release pipe.

The steam release valve must be installed before using the cooker.

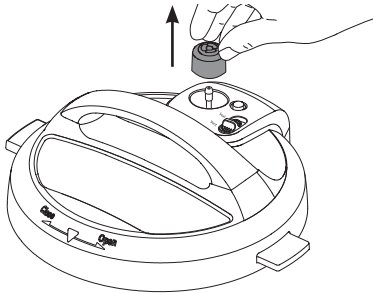

Install the steam release valve

Place the steam release valve on the steam release pipe and press down firmly.

The steam release valve sits loosely on the steam release pipe when installed properly but should remain in place when the lid is turned over.

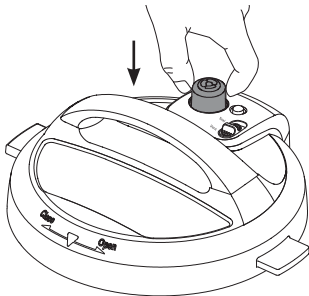

Anti-block shield

Remove the anti-block shield

Grip the lid like a steering wheel and use your thumbs to press firmly against the side of the anti-block shield (pressing towards the side of the lid and up) until it pops off the prongs underneath.

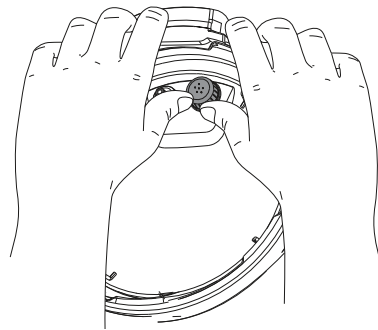

Install the anti-block shield

Place the anti-block shield over the prongs and press down until it snaps into position.

Do not attempt to operate the pressure cooker without the anti-block shield installed.

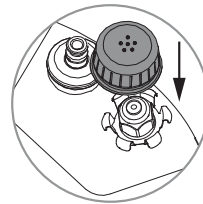

Illustrations in this document are for reference only and may differ from the actual product. Always refer to the actual product.

Care, cleaning and storage

Float valve and silicone cap

Remove the float valve

Place one finger on the flat top of float valve, then turn the lid over. Detach the silicone cap from the bottom side of the float valve. Remove the float valve from the top of the lid.

 Do not discard the float valve or silicone cap.

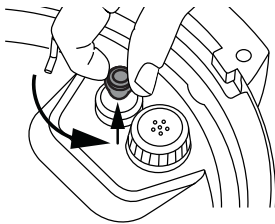

Install the float valve

Drop the narrow end of the float valve into the float valve hole on the top of the lid. Place one finger on the flat top of the float valve, then turn the lid over. Firmly attach the silicone cap to the bottom of the float valve.

Do not attempt to operate the pressure cooker without the float valve and/or silicone cap properly installed in the pressure cooking lid.

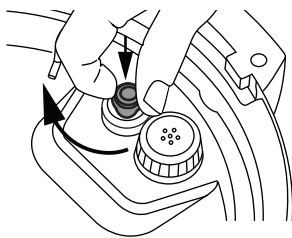

Condensation collector

The condensation collector sits at the back of the cooker base and catches any overflow from the condensation rim.

It should be installed before cooking, then emptied and rinsed out after each use.

Remove the condensation collector

Pull the condensation collector away from the cooker base; **do not pull down**. Note the tabs on the cooker base and the grooves on the condensation collector.

Install the condensation collector

Align the grooves on the condensation collector over the tabs on the back of the cooker base and slide the condensation collector into place.

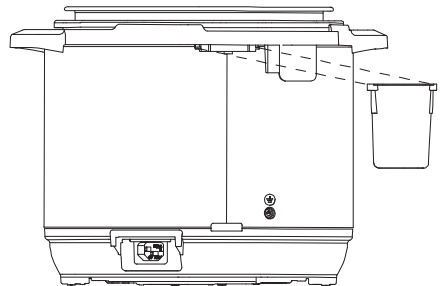

Illustrations in this document are for reference only and may differ from the actual product. Always refer to the actual product.

Warranty

One (1) Year Limited Warranty

This One (1) Year Limited Warranty applies to purchases made from authorized retailers of Instant Brands Inc. ("Instant Brands") by the original appliance owner and is not transferable. Proof of original purchase date and, if requested by Instant Brands, return of your appliance, is required to obtain service under this Limited Warranty. Provided the appliance was used in accordance with the use & care instructions, Instant Brands will, in its sole and exclusive discretion, either: (i) repair defects in materials or workmanship; or (ii) replace the appliance. In the event that your appliance is replaced, the Limited Warranty on the replacement appliance will expire twelve (12) months from the date of receipt. Failure to register your product will not reduce your warranty rights. The liability of Instant Brands, if any, for any allegedly defective appliance or part will not exceed the purchase price of a comparable replacement appliance.

What is not covered by this warranty?

1. Products purchased, used, or operated outside of the United States and Canada.
2. Products that have been modified or attempted to be modified.
3. Damage resulting from accident, alteration, misuse, abuse, neglect, unreasonable use, use contrary to the operating instructions, normal wear and tear, commercial use, improper assembly, disassembly, failure to provide reasonable and necessary maintenance, fire, flood, acts of God, or repair by anyone unless directed by an Instant Brands representative.
4. Use of unauthorized parts and accessories.
5. Incidental and consequential damages.
6. The cost of repair or replacement under these excluded circumstances.

EXCEPT AS EXPRESSLY PROVIDED HEREIN AND TO THE EXTENT PERMITTED BY APPLICABLE LAW, INSTANT BRANDS MAKES NO WARRANTIES, CONDITIONS OR REPRESENTATIONS, EXPRESS OR IMPLIED, BY STATUTE, USAGE, CUSTOM OF TRADE OR OTHERWISE WITH RESPECT TO THE APPLIANCES OR PARTS COVERED BY THIS WARRANTY, INCLUDING BUT NOT LIMITED TO, WARRANTIES, CONDITIONS, OR REPRESENTATIONS OF WORKMANSHIP, MERCHANTABILITY, MERCHANTABLE QUALITY, FITNESS FOR A PARTICULAR PURPOSE OR DURABILITY.

Some states or provinces do not allow for: (1) the exclusion of implied warranties of merchantability or fitness; (2) limitations on how long an implied warranty lasts; and/or (3) the exclusion or limitation of incidental or consequential damages; so these limitations may not apply to you. In these states and provinces, you have only the implied warranties that are expressly required to be provided in accordance with applicable law. The limitations of warranties, liability, and remedies apply to the maximum extent permitted by law. This limited warranty gives you specific legal rights, and you may also have other rights which vary from state to state or province to province.

Warranty

Product Registration

Please visit www.instanthome.com/register to register your new Instant Brands™ appliance. Failure to register your product will not diminish your warranty rights. You will be asked to provide the store name, date of purchase, model number (found on the back of your appliance) and serial number (found on the bottom of your appliance) along with your name and email address. The registration will enable us to keep you up to date with product developments, recipes and contact you in the unlikely event of a product safety notification. By registering, you acknowledge that you have read and understand the instructions for use, and warnings set forth in the accompanying instructions. Warranty Service

To obtain warranty service, please contact our Customer Care Department by phone at **1-800-828-7280** or by email to **support@instanthome.com**. You can also create a support ticket online at **www.instanthome.com**. If we are unable to resolve the problem, you may be asked to send your appliance to the Service Department for quality inspection. Instant Brands is not responsible for shipping costs related to warranty service. When returning your appliance, please include your name, mailing address, email address, phone number, and proof of the original purchase date as well as a description of the problem you are encountering with the appliance.

Instant Brands Inc.
495 March Road, Suite 200
Kanata, Ontario, K2K 3G1 Canada

[instanthome.com](https://www.instanthome.com)

© 2021 Instant Brands Inc
110-0039-01