

C5G1216 Adapter Installation Instructions

Tools required: 3/8 inch allen wrench, 1-1/8 inch wrench and torque wrench w/ 3/4 inch 8pt socket*



INSTALLERS - PLEASE GIVE THIS INSTRUCTION SHEET TO THE OWNER OF THE UNIT

Part 1 - Installation of locking collar:

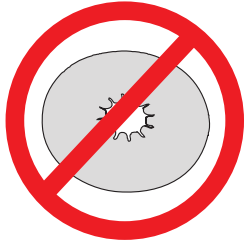

Remove the **Fifth Wheel Lube Plate or Lubrication Disk** from around your King Pin, (if your trailer is equipped with one.)

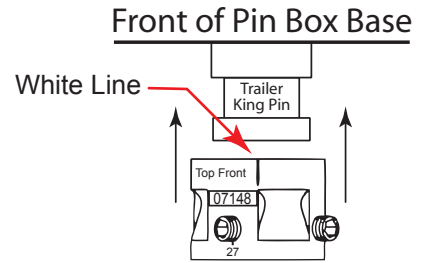
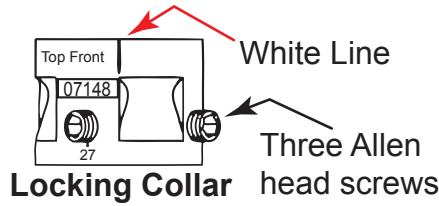

Slide the locking collar over the trailer king pin. Before tightening allen-head screws, rotate the collar so that the white line on the front of the collar is in the exact center of the front of the king pinbox. Tighten each of the allen-head screws evenly, **making sure the allen head screws rest on the bottom lip of the trailer king pin.** Firmly seat the allen-head screws flush with the surface of the collar. If screws are not flush, loosen and re-tightened evenly.

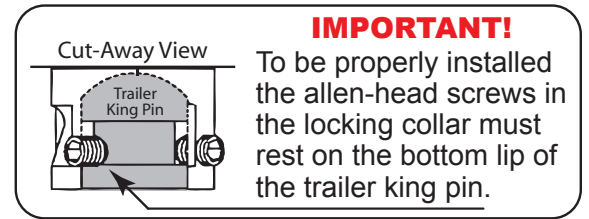

IMPORTANT!

To be properly installed the allen-head screws in the locking collar must rest on the bottom lip of the trailer king pin.

Part 2 - Installation of adapter:

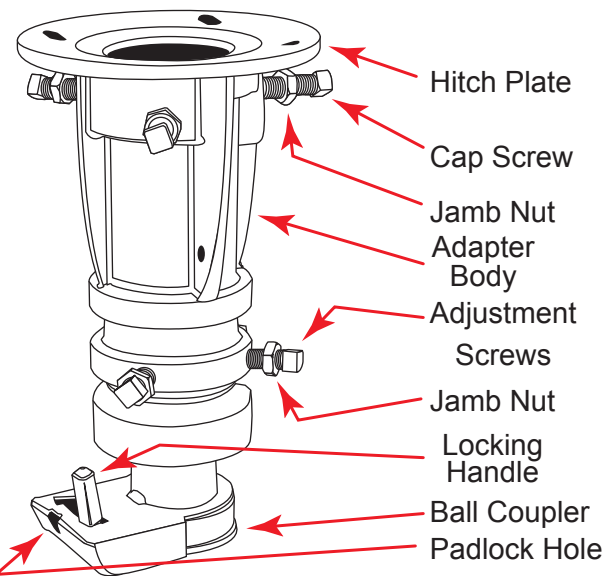

To prepare, move the Jamb Nuts out to the head of the Cap Screws. The adapter body weighs over 65 lbs, so an additional person may be required to help. Slide Adapter Body up over the Locking Collar, with the ball coupler label facing front and the red locking handle facing the driver's side of the truck bed. Begin tightening Cap Screws evenly, making sure the adapter body is moving upwards, until firmly against the pin box. Tighten down the Cap Screws to approx. **110 ft. lbs.** Tighten jamb nuts firmly. Check all vehicle trailer clearances and equipment each time before towing. Attach the safety chains to the adapter body.

Always secure safety chains to the truck bed connections and lock the ball coupler before towing.

We have included safety chains that combined, have an ultimate load strength of 15,200 lbs. If you are towing a load greater than 15,200 lbs., a purchase of third party safety chains would be required. Check your state and local laws to determine the strength needed to tow the trailer safely.

Follow the instructions on the reverse of this page to properly install the Positive Lock Handle.

Part 3 - Adjusting the adapter:

Raise your trailer with the adapter attached and back the truck under the trailer, centering the adapter over the gooseneck ball. Lower the trailer to a level towing position. Loosen the two Adjustment Screws and lower the Ball Coupler over the ball, securing it with the Locking Handle. Ensure there is no **RED** showing between the Ball Coupler and the Adapter Body. Tighten down the Adjustment Screws to approx. **110 ft. lbs.** Tighten jamb nuts firmly. **If you do not adjust the height of the adapter, you MUST tighten the adjustment screws and jam nuts before towing.**

*Proto brand 1/2" Drive, 3/4" Standard Impact Socket 8 points, 1-1/2" Overall Length. Mfr Part# J7424S

Help Line: 1-800-543-1732

The Original
CONVERT-A-BALL®
Interchangeable Hitch System Products

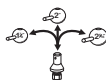

For Many More Original Convert-A-Ball® Products

Contact your local Convert-A-Ball dealer or

Call 1-308-254-7115 or Fax 1-308-254-7194

www.convert-a-ball.net • email: info@convert-a-ball.net



Made in The U.S.A.
Sidney, Nebraska

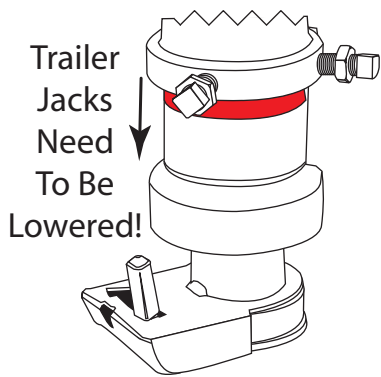

IMPORTANT WARNING!

Each ball coupler is marked in **RED** when its is too low to be safely connected to the adapter body. If you see red when you are hooking up your adapter, you need to lower the trailer jacks until there is **NO** red showing before tightening the adjustment screws and jamb nuts.

Bolt-On Kit

When properly installed as shown above we can guarantee this system will not separate from the king pin. If you would like the unit also to be bolted to the king pin box, a bolt kit is available at no charge. The kit contains containing four 1/2 inch Grade 5 bolts, nuts and washers.

Hitch Plate Bolt Holes

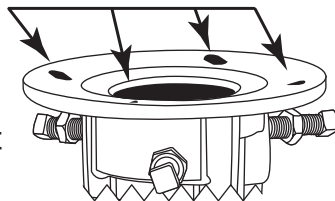

Disconnecting the coupler

If you are unable to move the coupler handle to uncouple your trailer, you may have negative tongue weight. (Up pressure on your ball coupler) Be sure you unlock the coupler before you jack the trailer up. Also you need to be on fairly level ground. If all else fails, call us at 800-543-1732.

LIMITED 2-YEAR WARRANTY:

- If a product fails due to a defect in material or workmanship within two years after purchase, we will replace it free of charge to the original purchaser.
- This warranty gives you specific legal rights and you may also have other rights, which may vary from state to state, province to province or country to country. CONVERT-A-BALL DISTRIBUTING, INC. IS NOT LIABLE FOR INCIDENTAL OR CONSEQUENTIAL DAMAGES. Some governments do not allow the exclusion or limitation of incidental or consequential damages, so the above limitation or exclusion may not apply to you. This warranty does not cover products that have been abused, altered, damaged, misused, cut or worn. To the extent permitted by law, CONVERT-A-BALL DISTRIBUTING, INC. DISCLAIMS ALL OTHER IMPLIED OR EXPRESS WARRANTIES INCLUDING WARRANTIES OF MERCHANTABILITY AND/OR FITNESS FOR A PARTICULAR USE.
- Replacement information and complete warranty information are available at www.convert-a-ball.net or you may call Convert-A-Ball Distributing, Inc. at 1-800-543-1732 or 308-254-7115.

Ball Coupler - Positive Lock Handle Instructions

Either end of the lock handle can be used to move the slide lever to the open or locked position from the side of the truck.

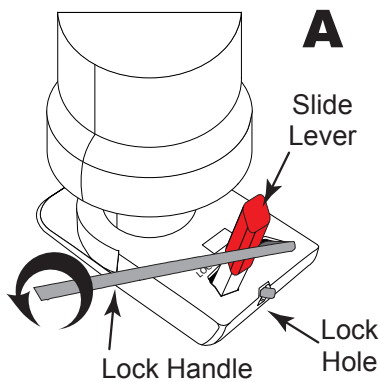

With the lock handle in front of the slide lever, twist curved end through lock hole in the base.

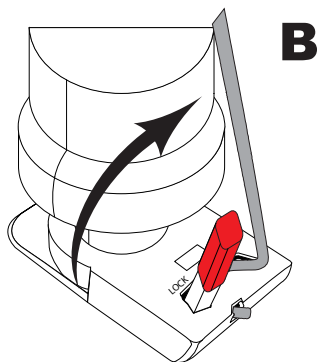

To achieve positive lock, lift the lock handle up and move behind the slide lever.

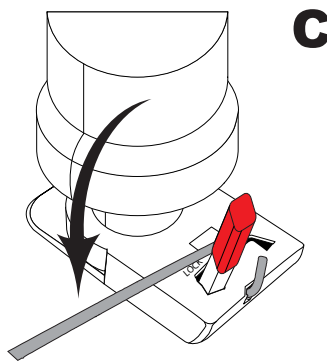

Lower the handle to the bed of the truck. This will prevent the sliding lever from moving from the locked position

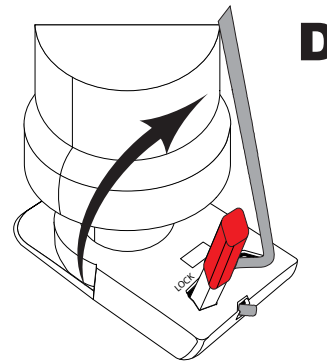

To Remove, lift the handle back up and over the slide handle.

Help Line: 1-800-543-1732

The Original
CONVERT-A-BALL®

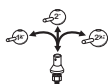

Interchangeable Hitch System Products

For Many More Original Convert-A-Ball® Products

Contact your local Convert-A-Ball dealer or

Call 1-308-254-7115 or Fax 1-308-254-7194

www.convert-a-ball.net • email: info@convert-a-ball.net



Made in The U.S.A.
Sidney, Nebraska