

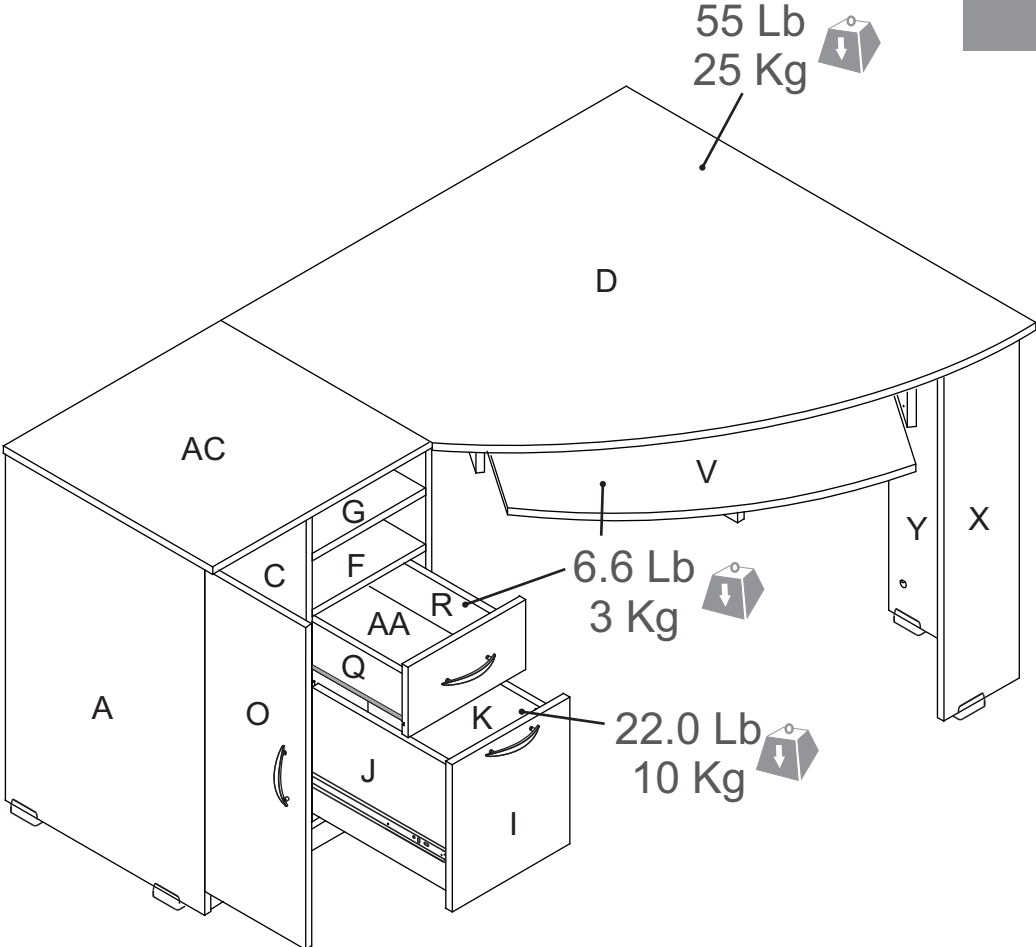

REF.: ET 3115

WORKSTATION

ESTACION DE TRABAJO



INVAL
 El mueble que uno quiere
 Furniture that you want



Thank you for purchasing this product. We trust that you will be completely satisfied with your product for years to come. This product is backed by a 5 year limited warranty and has been crafted with today's lifestyles in mind.

Le damos las gracias por adquirir este producto. Confiamos en que quede completamente satisfecho con su compra. Este producto tiene una garantía limitada de 5 años y ha sido creado atendiendo al estilo de vida de hoy día.

DO NOT RETURN TO STORE

If you need assembly assistance or parts replacement , please visit our Web site
www.invalamerica.com

Any other inquiries, please contact us toll free at 1-888-659-3512 
Monday thru Friday from 9:00 a.m. to 5:30 p.m. ET

Have all your purchase information ready when you contact us.

.....
NO DEVUELVA ESTE PRODUCTO A LA TIENDA

Si necesita remplazo de partes o ayuda para el armado de su nuevo mueble, por favor visite nuestra pagina de internet www.invalamerica.com

Cualquier otra solicitud que tenga, contactenos sin costo al 1-888-659-3512 
De lunes a viernes desde las 9:00 a.m. hasta las 5:30 p.m. hora del este.

Tenga toda su información de compra a mano cuando nos contacte.

¡-IMPORTANT-!

When calling or writing to us, please provide the OP number printed on the sticker of the warranty sheet so we can offer you the most efficient response.



¡-IMPORTANTE-!

Al llamar o escribirnos, por favor darnos el número de la OP que encontrará impreso en la calcomanía de la hoja de garantía con el fin de ofrecerle la más eficiente respuesta.

**-This instruction manual contains important information. Follow the consecutive order.
Please read and keep for future reference.**

**-Este Manual contiene información importante. Siga el orden consecutivo de las instrucciones.
Por favor léalo y guárdelo para consultas en el futuro.**



Two or more people are required to assemble and/or move this unit.
Se requiere de dos o más personas para armar y mover este mueble.



Unpack and assemble this unit in an spacious area. Assemble the unit on top of the empty box to prevent scratches.
Desempaque y arme este mueble en un area espaciosa. Arme el mueble sobre su caja, para no rayarlo.



Protect furniture from water and moisture. This furniture must not be used outdoors.
Proteja el mueble del agua y de la humedad. No ubique este mueble al aire libre.



Do not expose it to heat.
No lo exponga al calor.



Do not hit or tap with a hammer, unless it is indicated.
No lo golpee ni lo martille.



Do not paint or use abrasive elements to clean this furniture.
No pinte ni use elementos abrasivos para limpiar este mueble.



Do not drag or climb on your furniture. If you need to move it, lift it.
No lo arrastre ni se suba al mueble. Si necesita moverlo, levántelo.

TOOLS REQUIRED HERRAMIENTAS REQUERIDAS

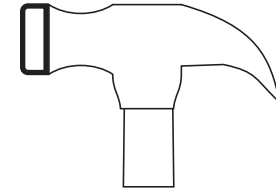

**HAMMER/
MARTILLO**

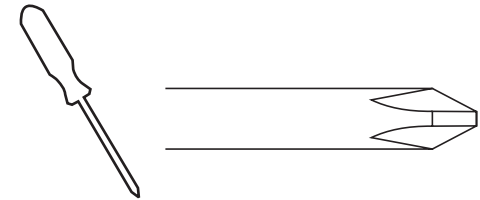

**PHILLIPS SCREWDRIVER /
ATORNILLADOR DE ESTRELLA**

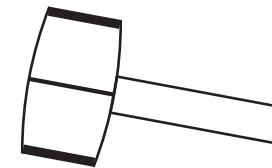

**RUBBER
HAMMER/
MARTILLO
DE GOMA**

IMPORTANT: Before proceeding to assemble this unit, read the instructions and inspect carefully the parts and hardware thoroughly.
If any part is missing, do not return to the store, please call toll free: In Colombia 01800 09 33444, Venezuela 0212-238-7584, Mexico 53447019 / 53445841 and in the USA, Canada, Puerto Rico and US Virgin Islands visit our Web page www.invalamerica.com.

IMPORTANTE: Antes de empezar a ensamblar este mueble, lea este instructivo y revise cuidadosamente las piezas y herrajes.
En caso de que le haga falta alguna pieza, no lo devuelva a la tienda, favor llamar a la línea gratuita en Colombia Colombia 01800 09 33444, Venezuela 0212-238-7584, Mexico 53447019 / 53445841 y para USA, Canada, Puerto Rico y US Virgin Islands visite nuestra página Web www.invalamerica.com.

ASSEMBLY SUGGESTIONS / RECOMENDACIONES DE ENSAMBLE

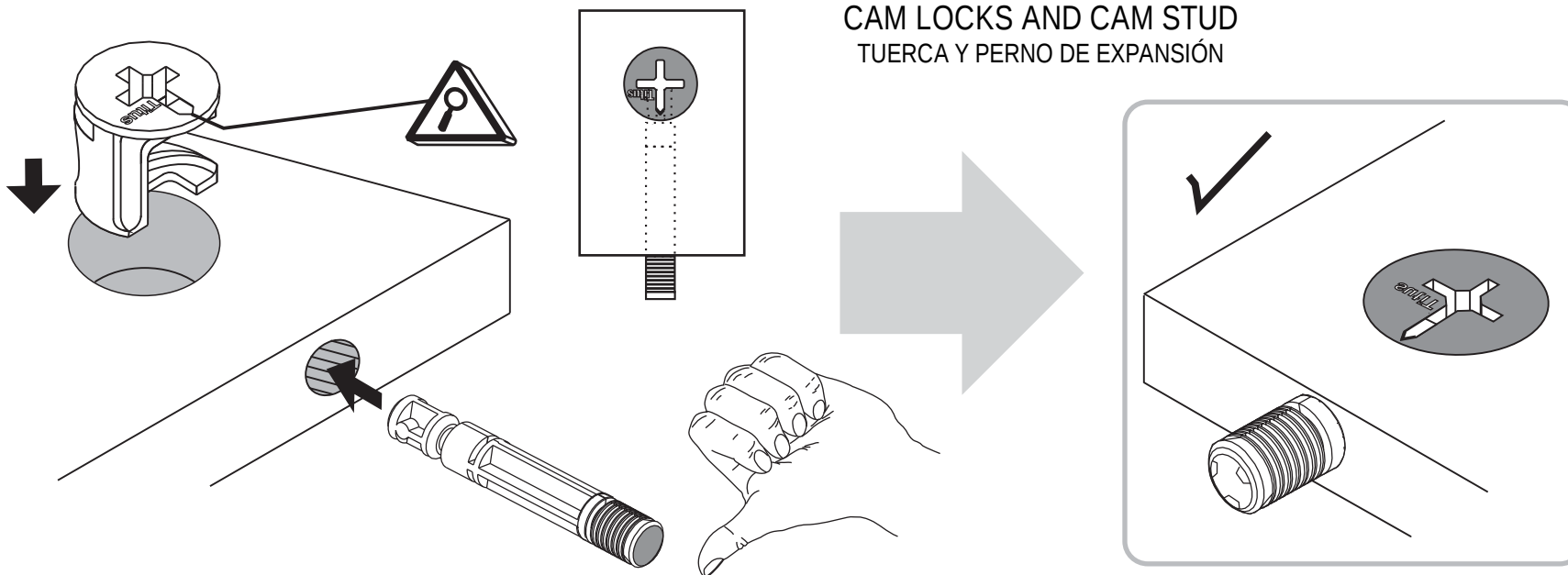

WOODEN DOWELS
TARUGOS

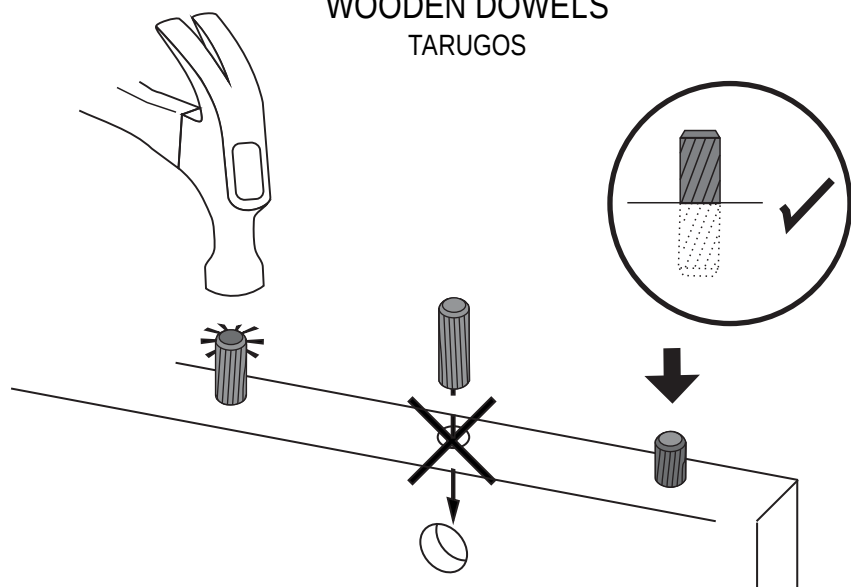

ADJUSTING THE PARTS
AJUSTE DE PIEZAS

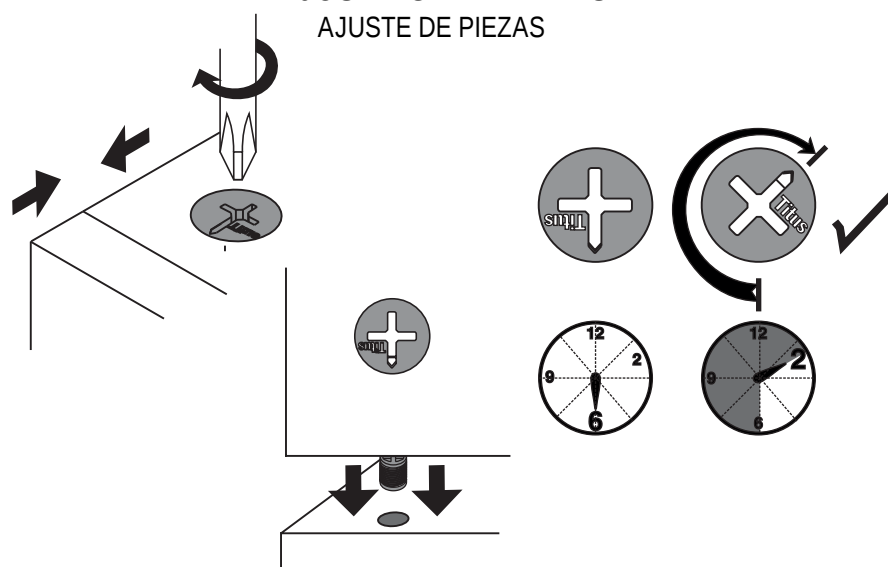

PARTS IDENTIFICATION/IDENTIFICACIÓN DE PIEZAS

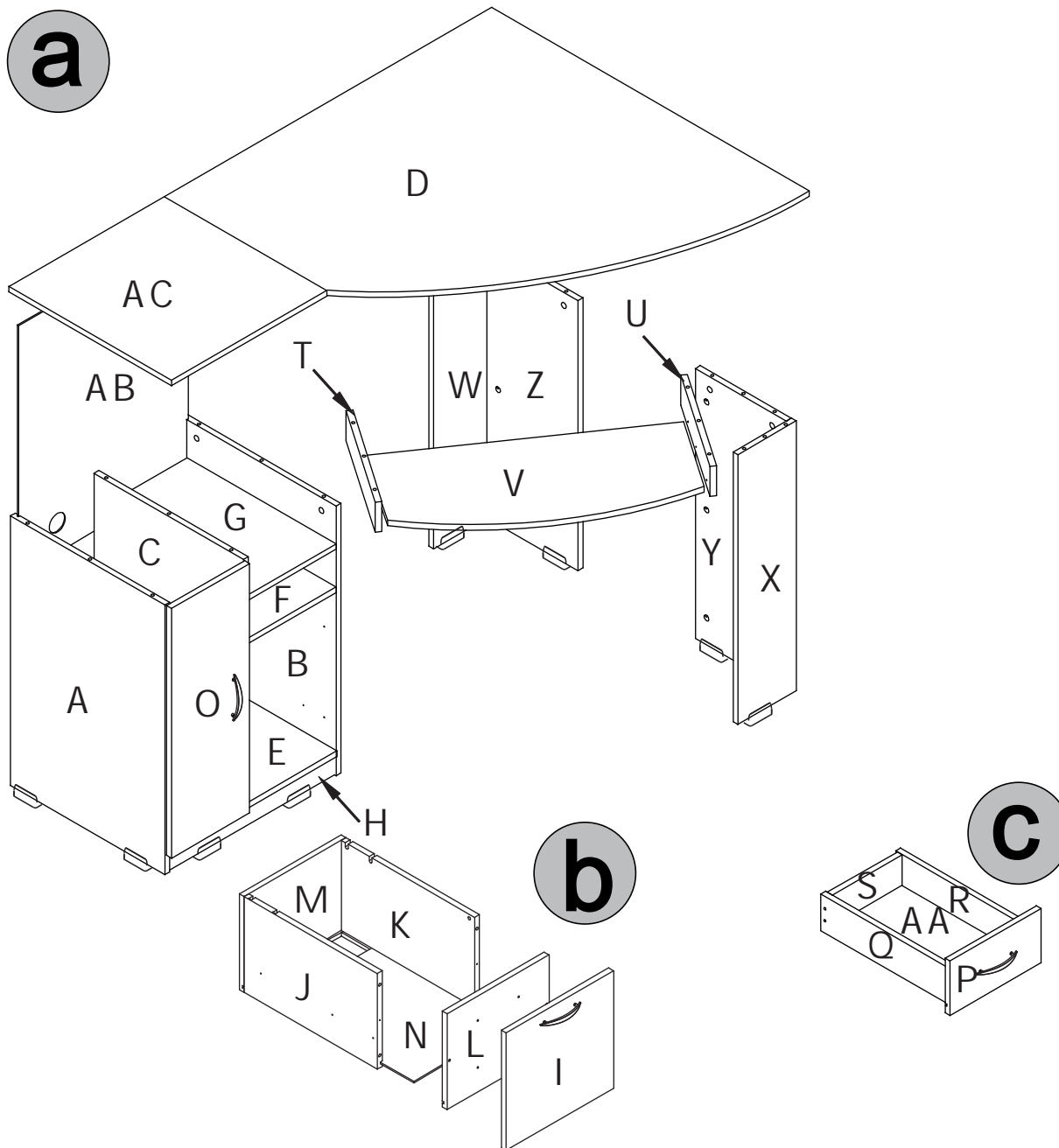

PARTS PIEZA	QUANTITY CANTIDAD
A	1
B	1
C	1
D	1
E	1
F	1
G	1
H	1
I	1
J	1
K	1
L	1
M	1
N	1
O	1
P	1
Q	1
R	1
S	1
T	1
U	1
V	1
W	1
X	1
Y	1
Z	1
AA	1
AB	1
AC	1

QUANTITY CANTIDAD	FROM DESDE	TO HASTA
29	A	AC

HARDWARE IDENTIFICATION/IDENTIFICACIÓN DE HERRAJES

1 WOODEN DOWELS/
TARUGOS MADERA

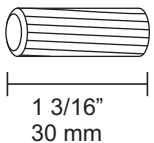

X
32

2 CAM STUDS/
PERNOS

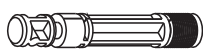

X
34

3 CAMS LOCKS/
TUERCAS



X
34

4 BLACK SCREWS/
TORNILLO NEGRO

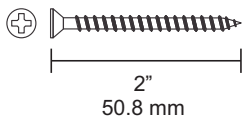

X
10

5 HINGE/
BISAGRA

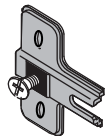

X
2

6 DOOR HINGE /
BISAGRA PUERTA



X
2

7 HINGE SCREW-ANGLE/
TORNILLO BISAGRA
-ANGULO

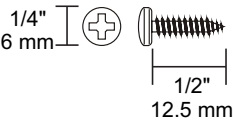

X
30

8 HANDLES AND
SCREWS/
MANIJAS Y
TORNILLOS

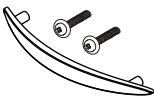

X
3

9 DRAWER - SLIDES SCREWS/
TORNILLOS
GAVETA - RIELES

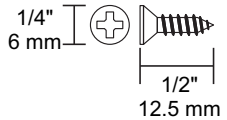

X
24

10 FULL EXTENSION SLIDES/
CORREDERAS FULL EXT.



X
2

11 KEYBOARD SLIDES/
RIELES PORTATECLADO

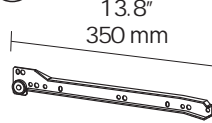

X
2

12 KEYBOARD SLIDES/
RIELES PORTATECLADO

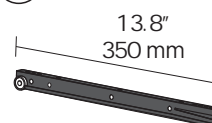

X
2

13 TUBE/
TUBO

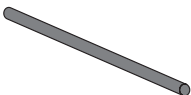

X
2

14 SLIDES/
RIELES

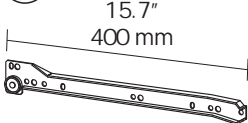

X
2

15 DRAWER SLIDES/
RIELES CAJONES

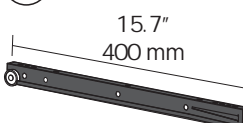

X
2

16 GLIDER SCREW/
TORNILLO DESLIZADOR

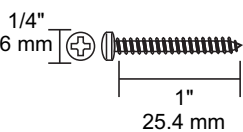

X
16

17 PANEL SUPPORTS/
SOPORTES ENTREPAÑOS

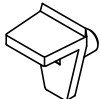

X
4

18 GLIDERS/
DESILIZADORES

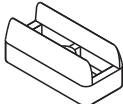

X
12

19 METAL PLATE/
PLATINA METALICA

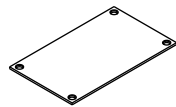

X
2

20 SCREWS METAL
PLATES/
TORNILLOS
PLATINAS METALICAS

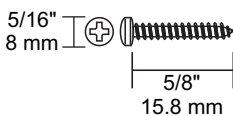

X
8

21 ANGLE BRACKET/
ANGULO METALICO



X
4

PARTS PREPARATION / PREPARACIÓN DE PARTES

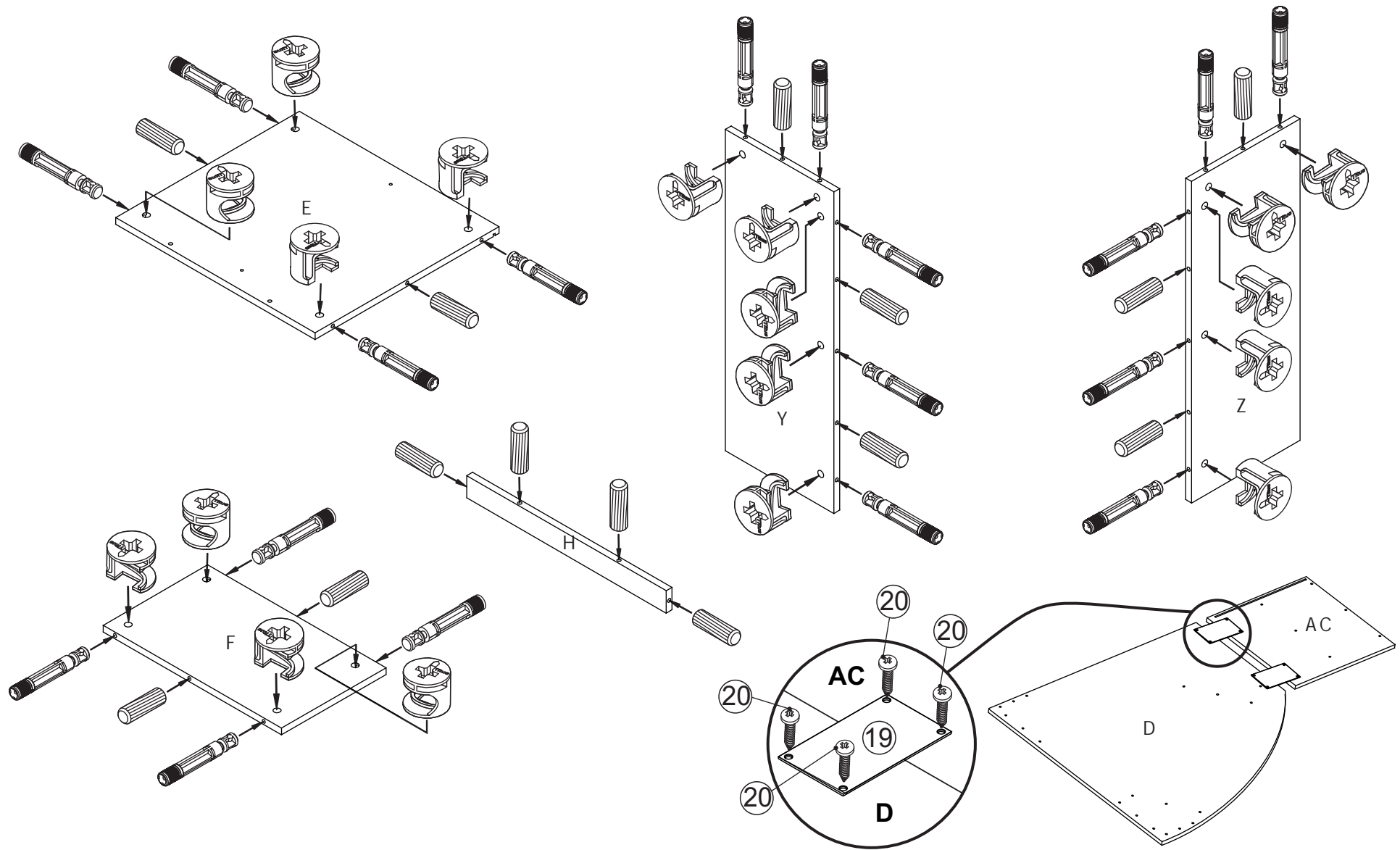

1 WOODEN DOWELS/
TARUGOS MADERA

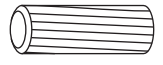

X
14

2 CAM STUDS/
PERNOS

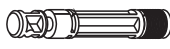

X
18

3 CAM LOCKS/
TUERCAS



X
18

19 METAL PLATE/
PLATINA METAL

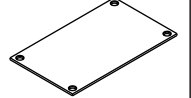

X
2

20 SCREWS METAL
PLATES/
TORNILLOS
PLATINAS METALICAS

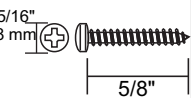

X
8

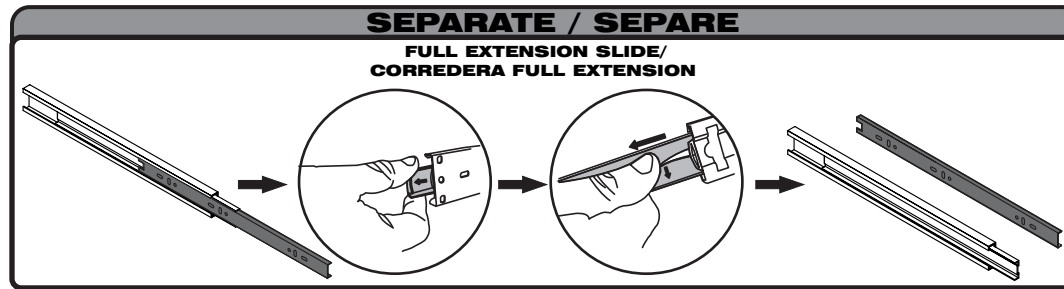
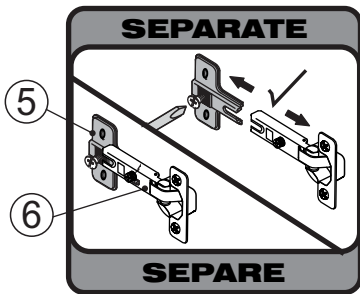

**SUGGESTION /
ASSEMBLE ON A FLAT
AND CLEAN SURFACE
TO AVOID DAMAGES./
ARME SOBRE UNA
SUPERFICIE LIMPIA Y
PLANA
PARA EVITAR POSIBLES
AVERIAS.**

SUGERENCIA

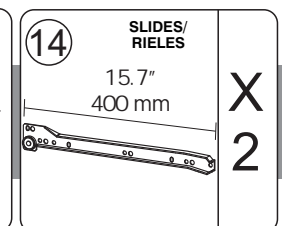
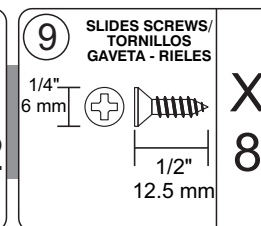
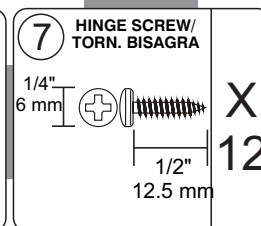
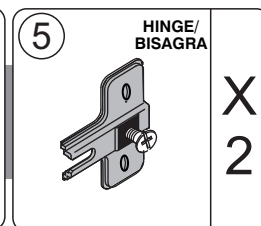
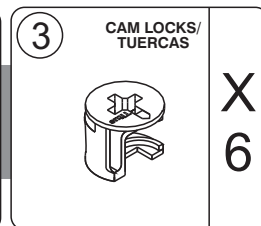
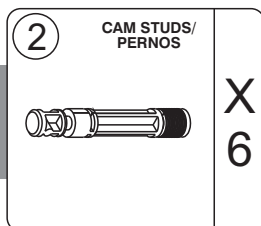
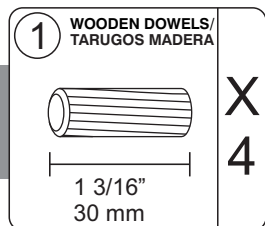
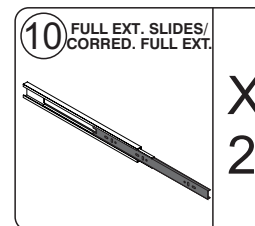
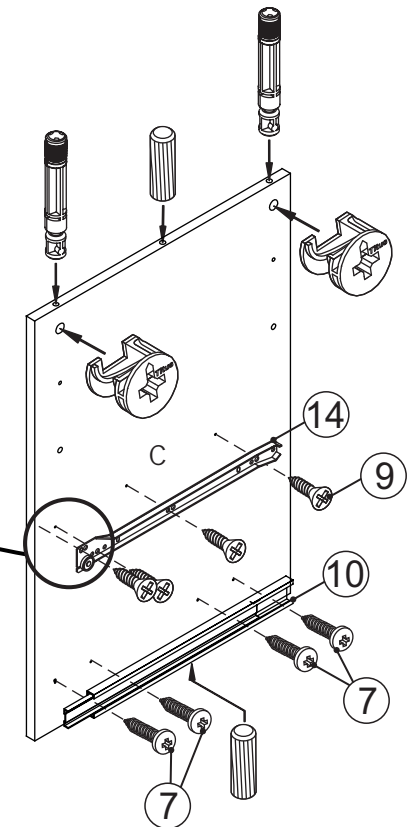
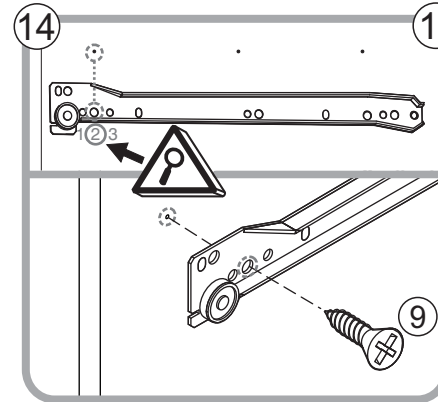
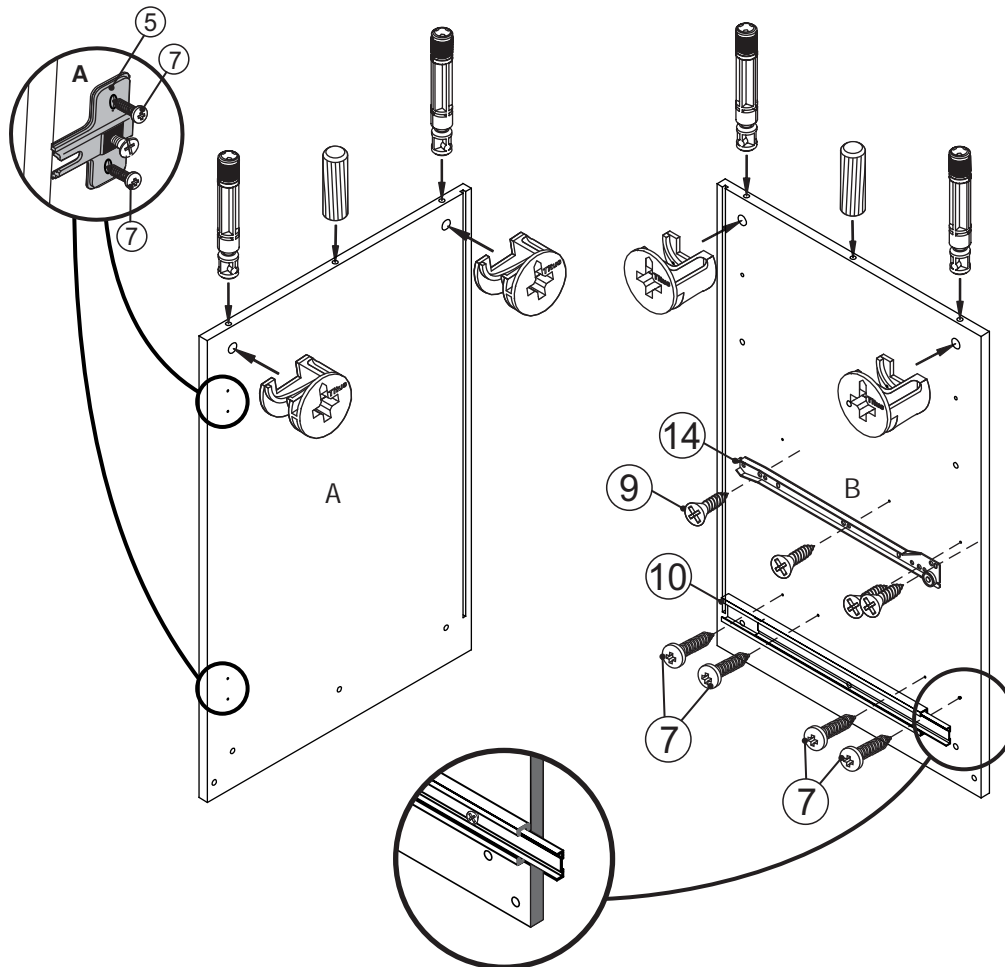

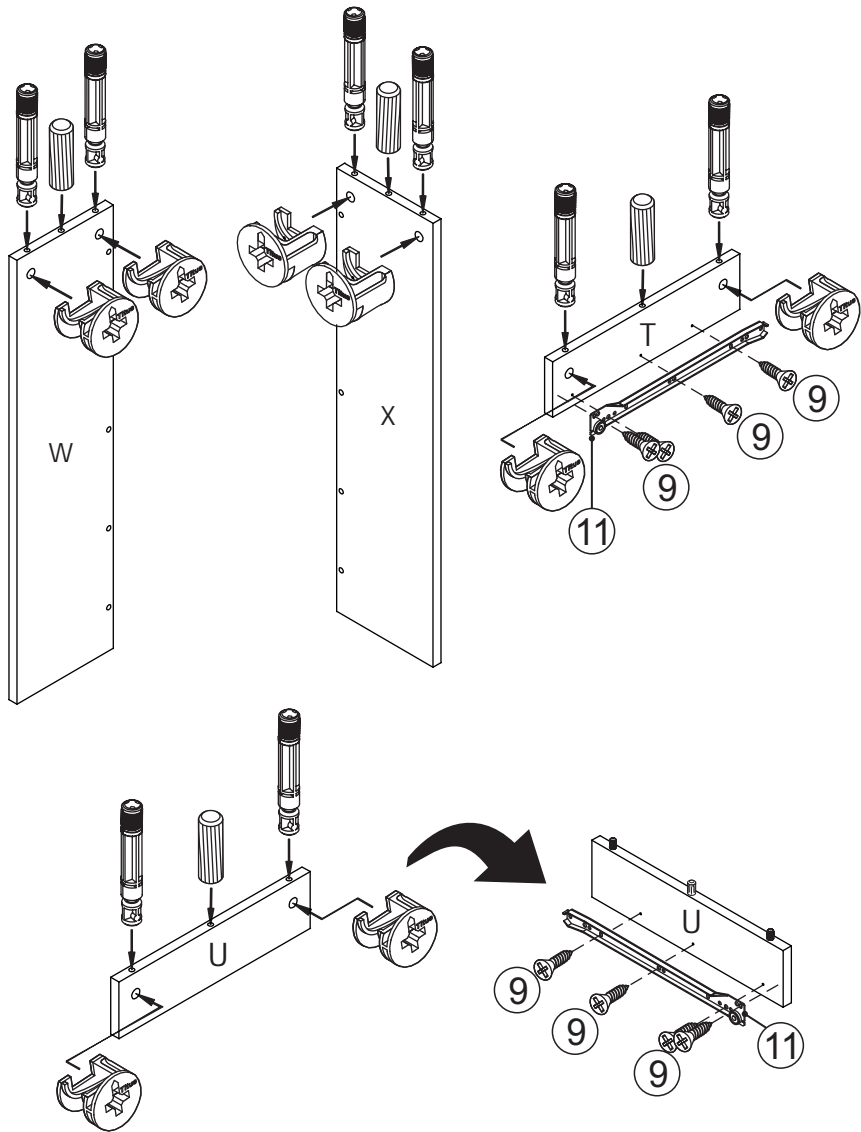

**DESK ASSEMBLY
ARMADO DEL ESCRITORIO**

a

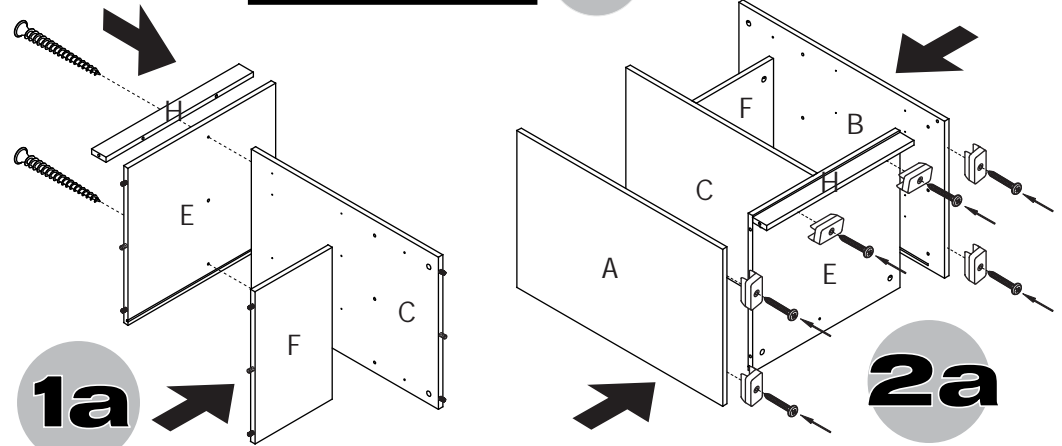

1a

2a

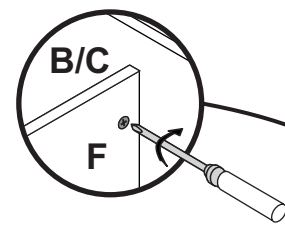

3a

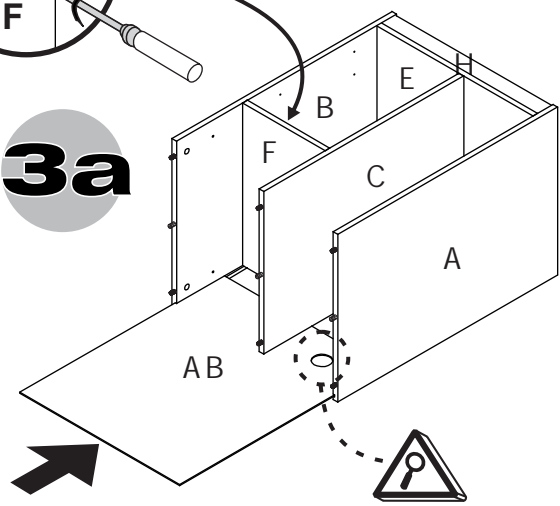
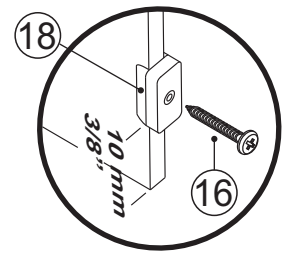

16 GLIDER SCREW/
TOR. DESLIZADOR

X 6

1 WOODEN DOWELS/
TARUGOS MADERA

X 4

2 CAM STUDS/
PERNOS

X 8

3 CAM LOCKS/
TUERCAS

X 8

4 BLACK SCREWS/
TORN. PAVONADO

X 2

9 SLIDES SCREWS/
TORNILLOS
GAVETA - RIELES

X 8

11 KEYBOARD SLIDES/
RIELES PORTATEC.

X 2

18 GLIDERS/
DESLIZADORES

X 6

4a

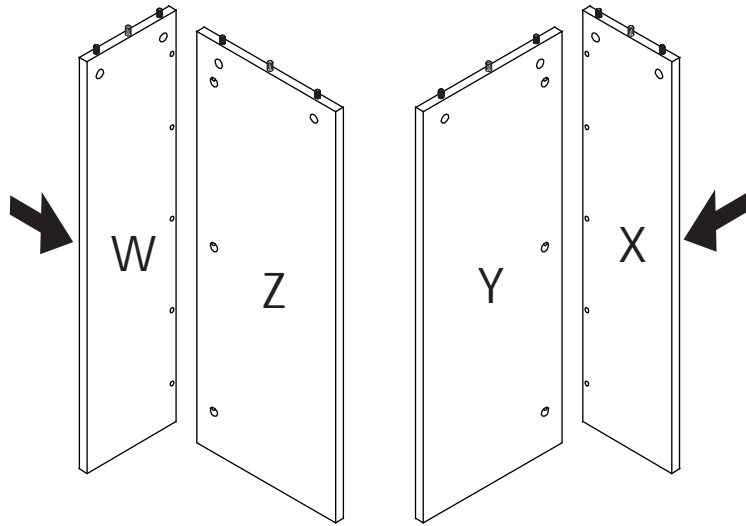

5a

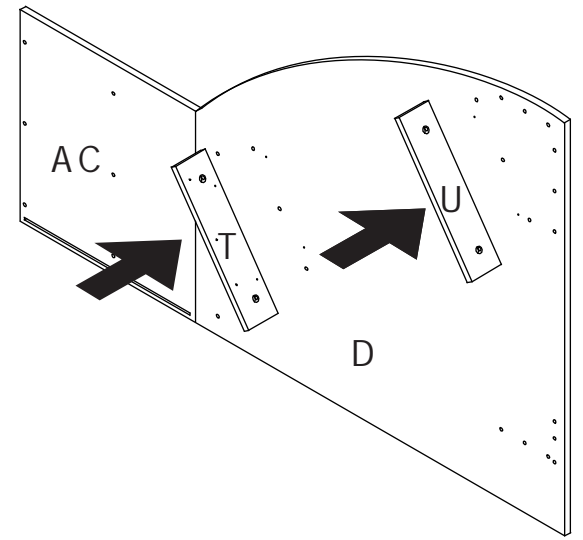

6a

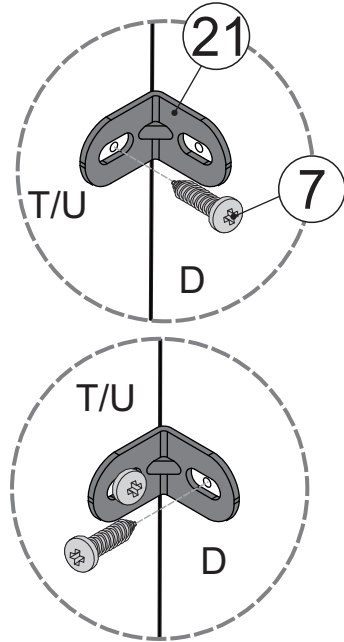
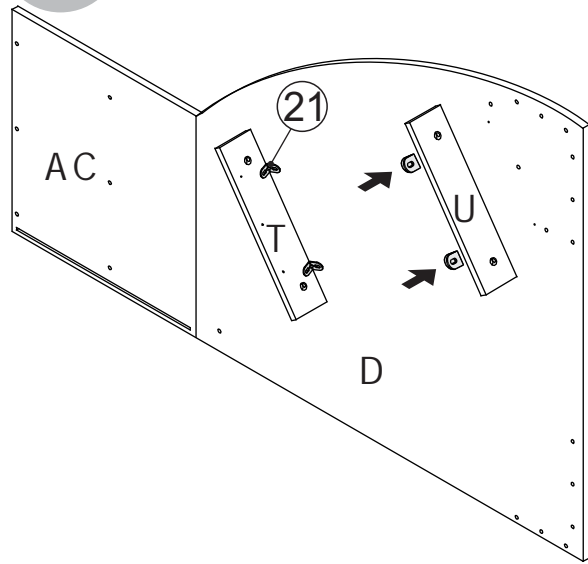

7a

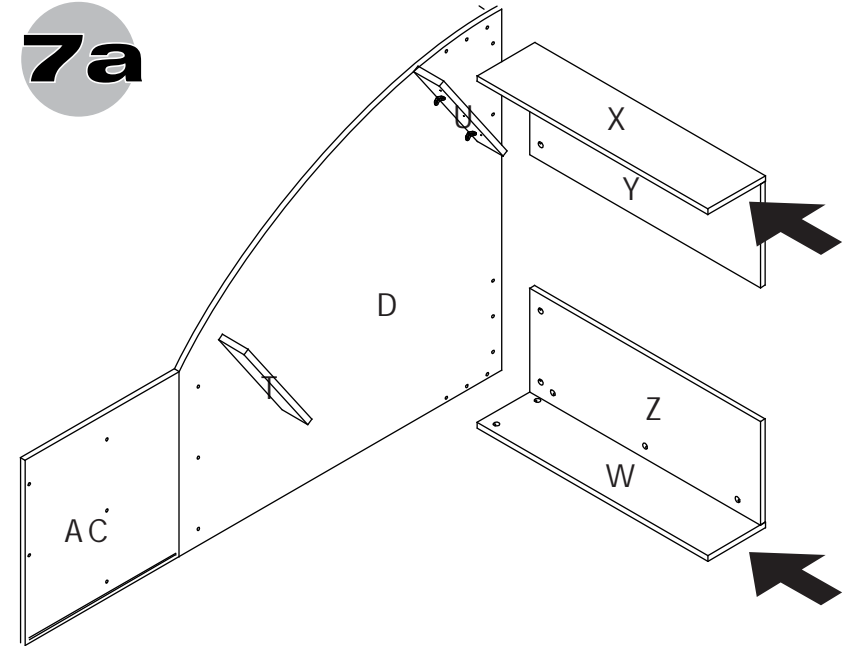

21 ANGLE BRACKET/
ANGULO METALICO

X 4

7 HINGE SCREW-ANGLE/
TORNILLO BISAGRA
-ANGULO

1/4"
6 mm

1/2"
12.5 mm

X 8

8a

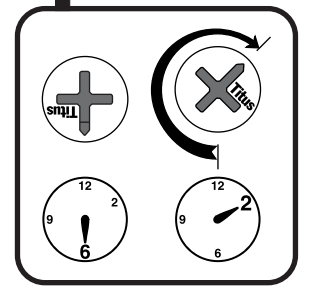
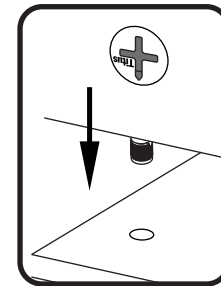
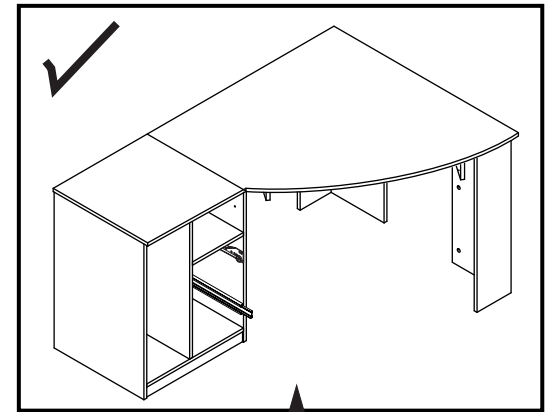
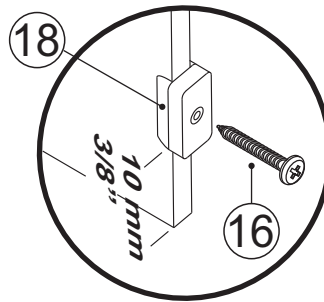
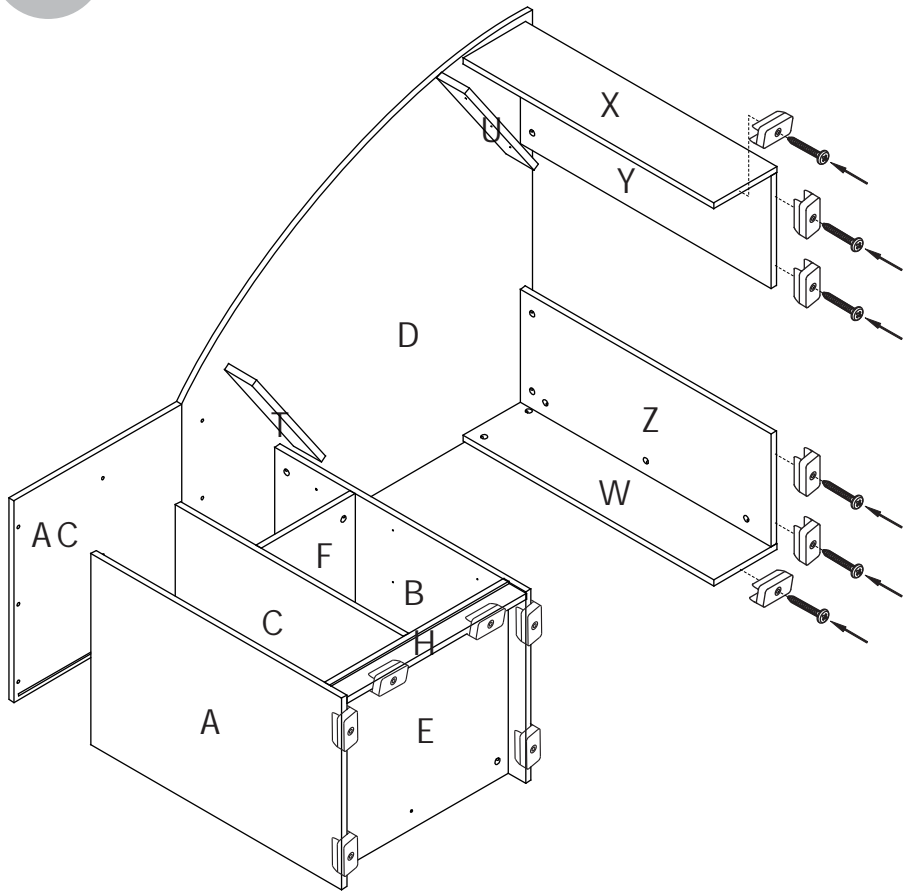

AFTER THE PARTS ARE CONNECTED,
SCREW AS SHOWN



16	GLIDER SCREWS/ TORN. DESLIZADOR	X
	1/4" 6 mm	6
	3/4" 19 mm	

18	GLIDERS/ DESLIZADORES	X
		6

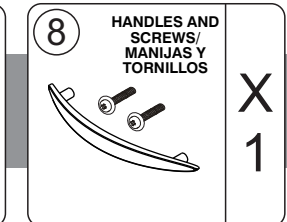
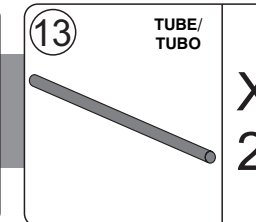
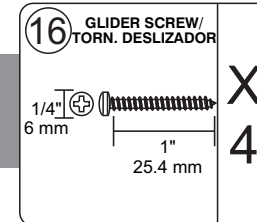
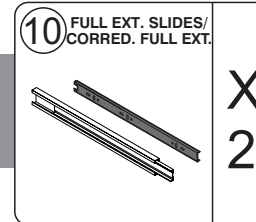
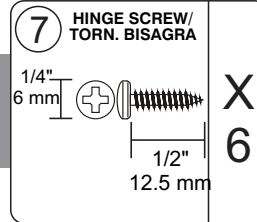
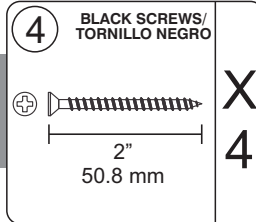
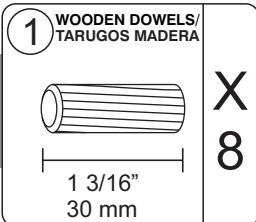
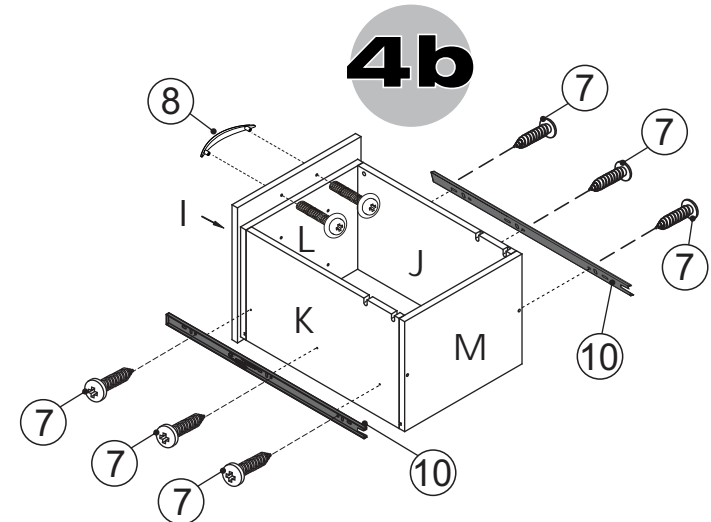
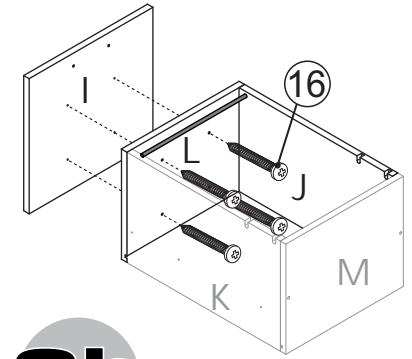
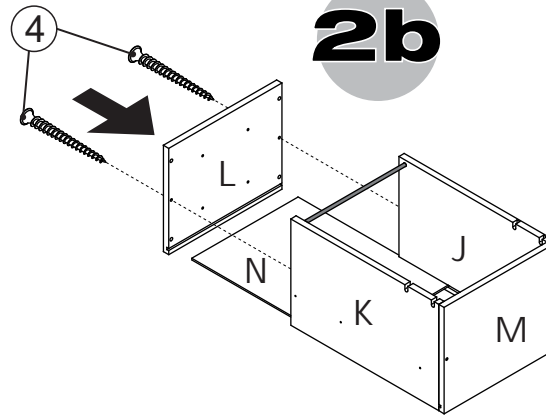
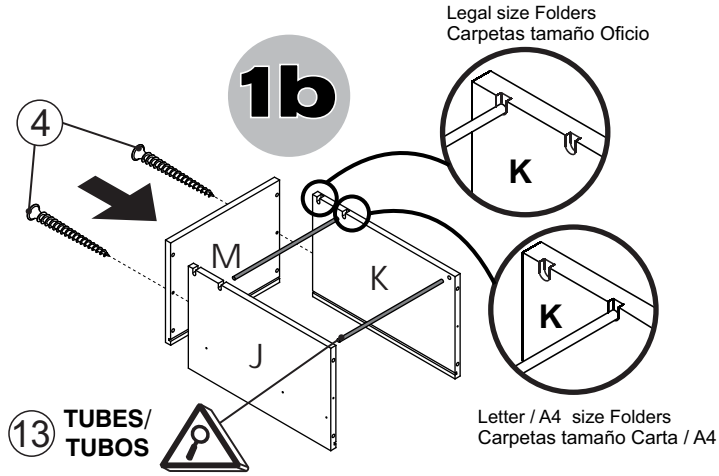
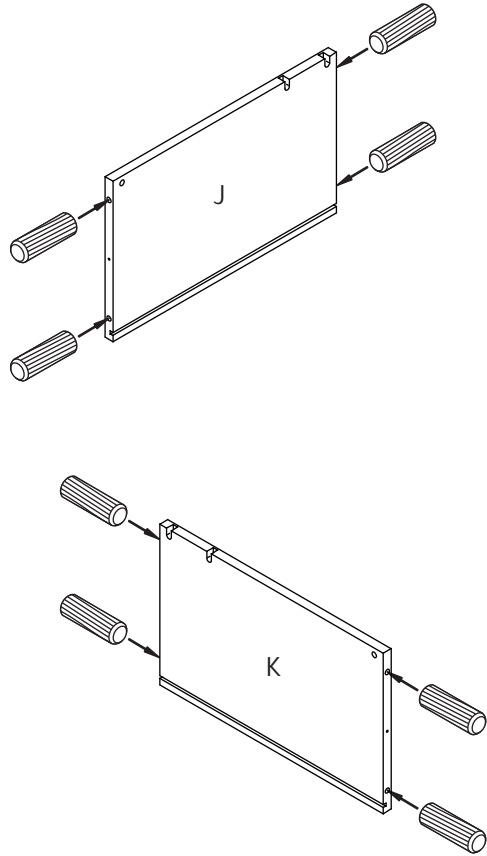
b**DRAWER ASSEMBLY/
ARMADO DEL CAJON**

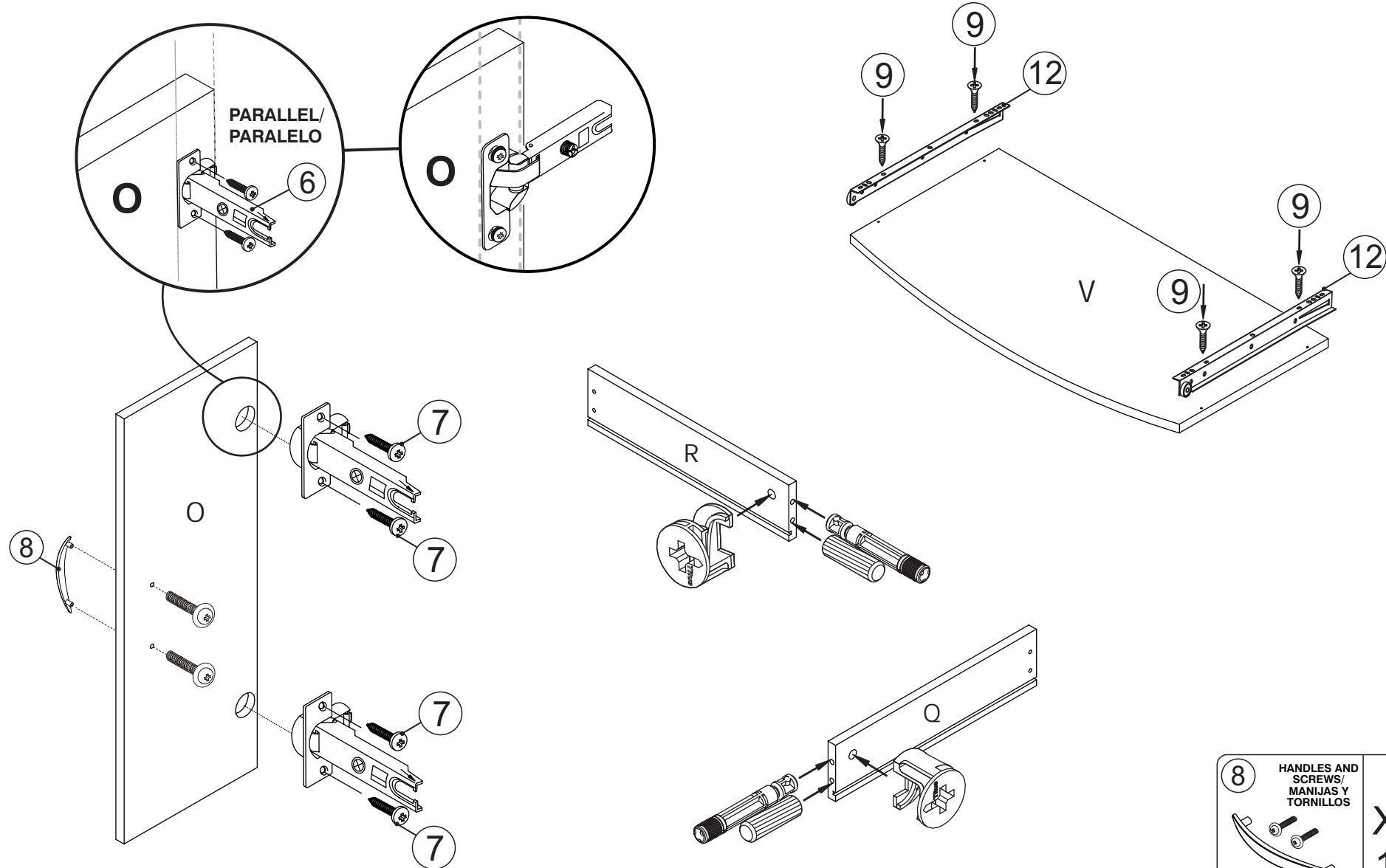

1 WOODEN DOWELS/
TARUGOS MADERA

X 2

1 3/16"
30 mm

2 CAM STUDS/
PERNOS

X 2

3 CAM LOCKS/
TUERCAS

X 2

6 DOOR HINGE /
BISAGRA PUERTA

X 2

7 HINGE SCREW/
TORN. BISAGRA

1/4"
6 mm

X 4

1/2"
12.5 mm

9 SLIDES SCREWS/
TORNILLOS
GAVETA - RIELES

1/4"
6 mm

X 4

1/2"
12.5 mm

12 KEYBOARD SLIDE/
RIEL PORTATEC.

13.8"
350 mm

X 2

8 HANDLES AND
SCREWS/
MANIJAS Y
TORNILLOS

X 1

1c

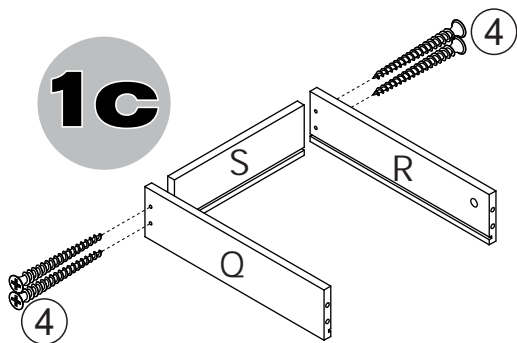

DRAWER ASSEMBLY ARMADO DEL CAJON



2c

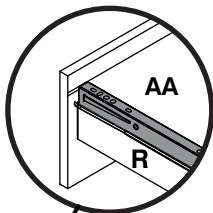
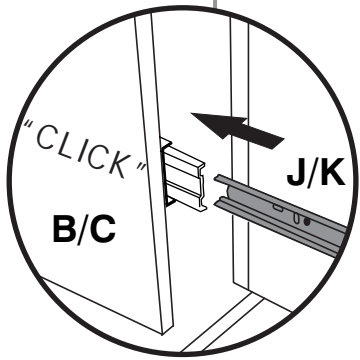
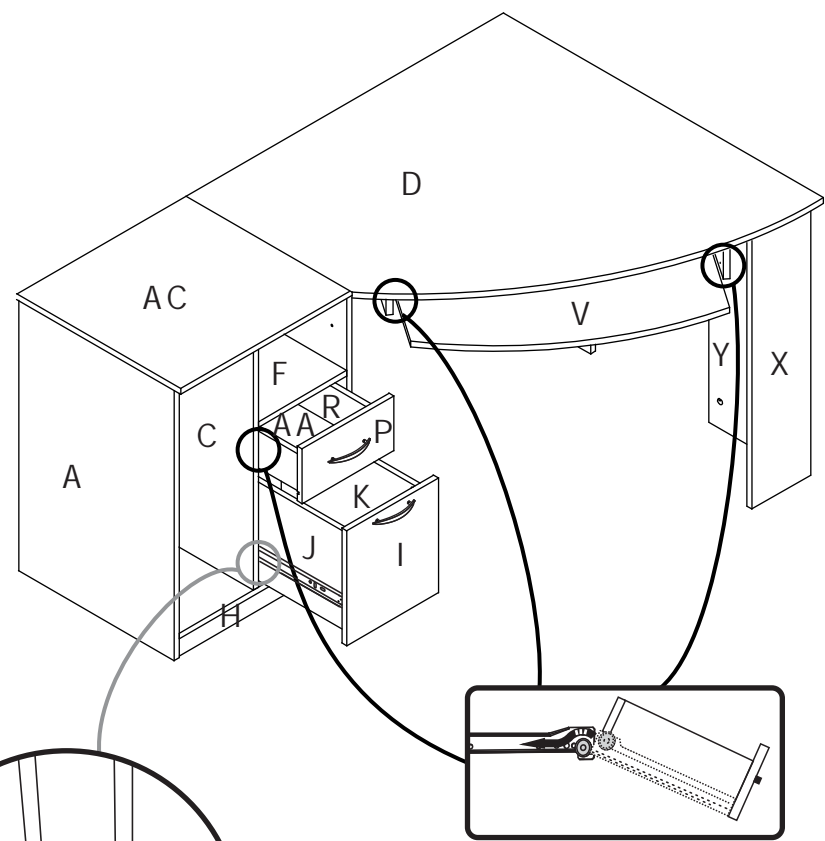
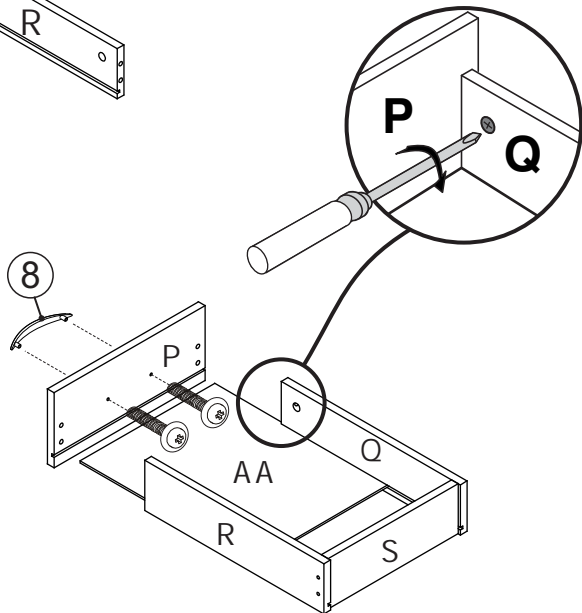

3c

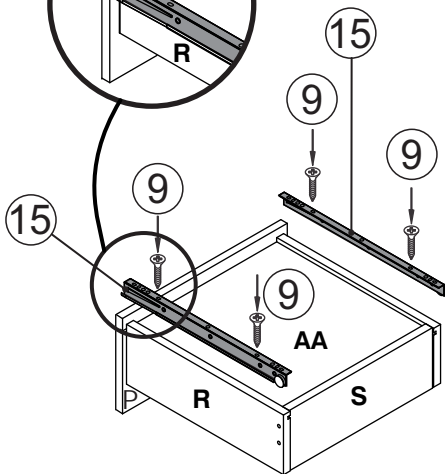

4 BLACK SCREWS/
TORN. PAVONADO

2"
50.8 mm

X

4

8 HANDLES AND
SCREWS/
MANIJAS Y
TORNILLOS

X

1

9 SLIDES SCREWS/
TORNILLOS
GAVETA - RIELES

1/4"
6 mm

1/2"
12.5 mm

X

4

15 DRAWER SLIDES/
RIELES CAJONES

15.7"
400 mm

X

2

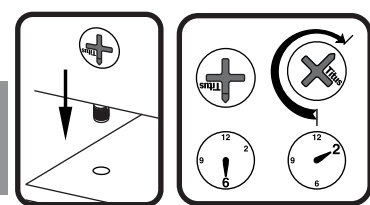

AFTER THE PARTS ARE CONNECTED,
SCREW AS SHOWN

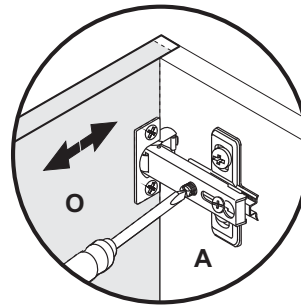
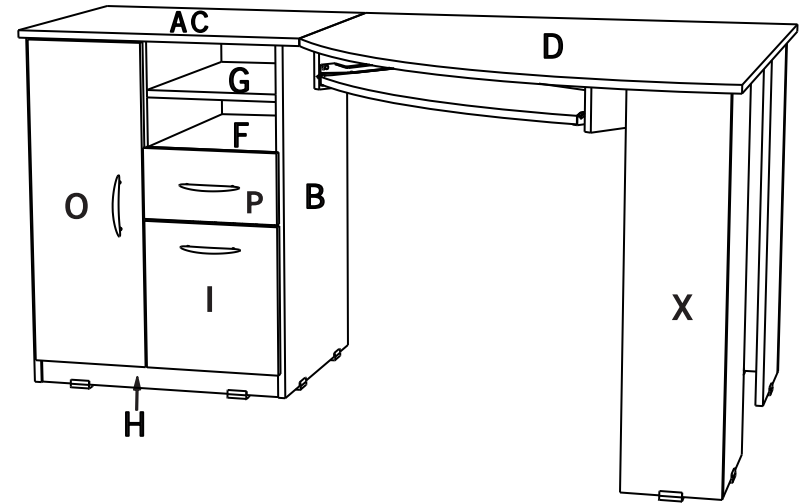
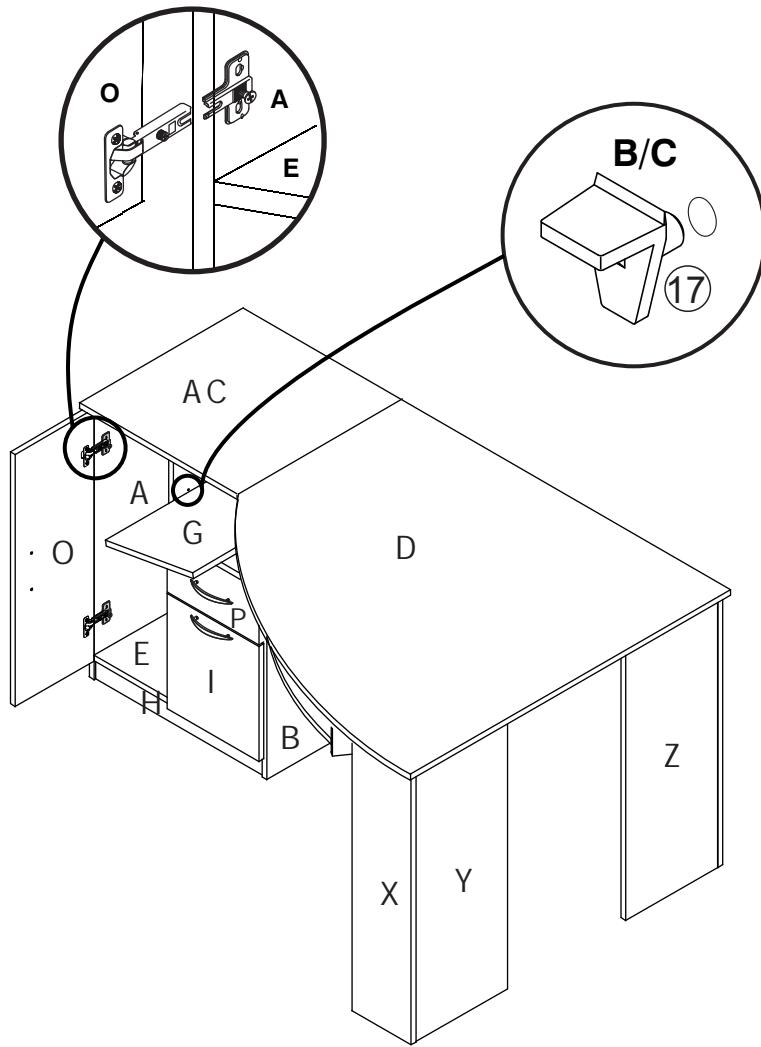

AJUSTE LATERAL
LATERAL ADJUSTMENT

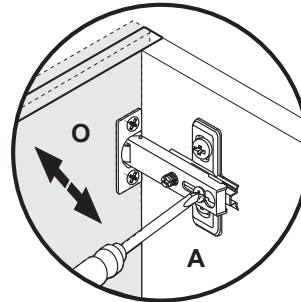

DEPTH ADJUSTMENT
AJUSTE DE PROFUNDIDAD

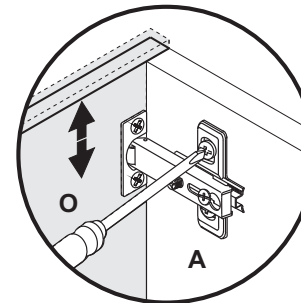

HEIGHT ADJUSTMENT
AJUSTE DE ALTURA

CONGRATULATIONS!, this way you finished assembling your furniture.

¡FELICITACIONES!, de esta manera usted termina de armar su mueble.

17 PANEL SUPPORTS/
SOPORTES ENTREPAÑOS

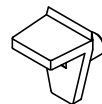

X
4