

BergHOFF[®] TRONIC



MANUAL



1810027



2213735



1810003



2207123



1. Power "ON/OFF" button
2. Function button toggles between POWER / TEMP COOK / TIMER (where applicable)
3. Power Cook 1-10 (300W-1800W - 2207123)
4. Temp Cook 60°C – 200°C (175°F - 450°F)
5. Timer (150')
6. Arrow up raises TEMP or POWER, increases TIME
7. Arrow down lowers TEMP or POWER, decreases TIME
8. Cook surface (glass or ceramic)
9. Feet

(Images for reference only, your model may be slightly different)

Welcome to the World of BergHOFF

BergHOFF is always ahead of the curve, leading worldwide supplier of the induction cooktop, tableware and kitchenware in both the private and commercial sectors. Specializing in modern technology, defined quality, remarkable performance.

BergHOFF has grown to a highly sophisticated, successful international corporation, forming an icon for innovation and perfection in the United States market, and the European markets of Belgium, the Netherlands, Germany, France, Spain, Greece, Russia, Poland, Hungary and many other countries. The United States headquarters is located in Odessa, Florida with distribution centers in both Florida and California.

BergHOFF also operates two research and development centers to bring customers the edge they need to stay ahead of the curve in this rapidly diversifying industry.

We look forward to earning your business as current customers and new customers alike. As always.....BergHOFF wishes you a nutritious and healthy lifestyle.

1. General information		
1A.	About this instruction manual	- 6 -
1B.	Symbols explained	- 6 -
1C.	Updates and translations	- 7 -
1D.	Copyright protection	- 7 -
1E.	Declaration of conformity	- 7 -
2. Technical information		
2A.	Technical specifications	- 8 -
2B.	Control panel / keypad	- 8 -
3. Packing, storage and transport		
3A.	Delivery check	- 9 -
3B.	Packing	- 9 -
3C.	Storage	- 9 -
4. Preparing your induction cooktop for use		
4A.	Grounding	- 10 -
4B.	Electrical installation requirements	- 10 -
5. Safety		
5A.	General information	- 11 -
5B.	Commercial use and safety instructions of this appliance	- 11 -
5C.	Expected use	- 12 -
6. Installing and operating tips		
6A.	The function mode and product advantages	- 12 -
6B.	General operation and important information	- 13 -
6C.	Induction and non-induction cookware	- 15 -
6D.	Connection and installation	- 16 -
6E.	Operating the cooktop	- 17 -
7. Cleaning and safety procedures		
7A.	Safety advice	- 18 -
7B.	Cleaning	- 19 -
7C.	Maintenance	- 19 -
8. Waste disposal		- 19 -
9. Warranty information		- 20 -
10. Error code list		- 21 -
11. Important Safegurards		- 26 - -

1. General information

1A. About this manual

This manual contains information about the installation, operation and maintenance of the BergHOFF appliance and should be considered an important source of information and as a reference guide. Awareness of the safety instructions and instructions for use in this manual will ensure safe and correct use of this appliance. In addition to the information given here, you should comply with any local health and safety controls and generally applicable safety regulations. The BergHOFF manual is part of the product and should be kept at hand and should be easily accessible for anyone installing, operating, maintaining or cleaning the appliance.

Note: This manual applies to different models of the induction cooktop. The cooktop you have purchased may not contain all parts of which are covered in this manual.

1B. Symbols explained

In this manual, symbols are used to highlight important safety signs and instructions and any advice relating to the device. The instructions should be followed very carefully to avoid any risk of accident, personal injury or equipment damage.



WARNING!

A "warning" symbol highlights hazards and dangers which could lead to injury. Please follow the instructions very carefully and proceed with special care in these cases.



WARNING! Electrical hazard!

A "warning electrical hazard" symbol draws your attention to potential electrical hazards. If you do not follow the safety instructions, you may risk injury or death.



CAUTION!

The "caution" symbol highlights instructions, which should be followed to avoid any risk of damage, malfunctioning and/or breakdown of the appliance. In addition, it is possible that the warranty will be voided if those instructions are not complied with.



NOTE!

The "note" symbol highlights tips and information; which could give you indications for efficient and trouble-free operation of the BergHOFF appliance.

1C. Updates and translations

The instruction manual was translated with all due care and attention. However, we do not accept liability for any translation errors. The Belgian version of this instruction manual is definitive. All the information and instructions in this manual take into account standard safety regulations, current known levels of technical advancement as well as the experience we at BergHOFF have developed over many decades. If a special model is delivered, the actual description may differ from the descriptions and illustrations in this manual. This is also the case for special orders or when the appliance has been modified in line with new technology. For any remaining questions, please contact the manufacturer or your local distributor.



NOTE!

Carefully read this entire manual, all warnings and other signs before using the appliance. The manufacturer is not responsible for any damage or malfunction resulting from not following the instructions for use.

The BergHOFF manual should be kept at hand and should be easily accessible for everyone who works with this appliance. We reserve the right to make technical changes for purposes of developing and improving the appliance's performance.

1D. Copyright protection

The manual texts, drawings, images or other illustrations are copyright protected. No part of this publication may be reproduced, transmitted, or used in any form or by any means without permission in writing from the manufacturer. Any unauthorized use of this publication is subject to claims for damages. All rights reserved.



NOTE!

The contents, texts, drawings, pictures and any other illustrations are copyright protected and subject to other protection rights. Any person unlawfully using this publication is liable to criminal prosecution.

1E. Declaration of conformity

The appliance complies with the current standards and directives of the ETL. We certify this in the ETL declaration of conformity. If required, we will be glad to send you a copy of the ETL listing. HOUSEHOLD USE conform to UL, NSF (2207123) for is applied for.

2. Technical information

2A. Technical specifications

Name	PRO Induction Cooking Unit	Induction Stove	Induction Stove
Item No.	2207123	1810003	2213735 - 1810027
Model:	BHI_01SS	BH_003	BHI_01S - BHI_01B
Cooking top:	SCHOTT CERAN GLASS	Black Glass	Ceramic glass
Temperature range:	60°C - 232°C	60°C - 200°C	60°C - 200°C
Power:	300 W - 1800 W	260 W - 1600 W	260 W - 1600W
Connection:	100-120V 60 Hz	100-120V 60 Hz	100-120V 60 Hz
Dimensions:	13" (330 mm) x 15 1/4" (390 mm) x 4" (100 mm)	13 1/3" (340 mm) x 12 1/2" (317 mm) x 2 1/2" (64 mm)	13 1/3" (340 mm) x 11 3/4 (300 mm) x 2 1/4 (60 mm)
Weight:	12 lbs / 5.40 kg	6,6 lbs / 3 kg	5,6 lbs / 2,55 kg

2B. Control panel/keypad

(Images for reference only, your model may be slightly different, this is for model 2207123)

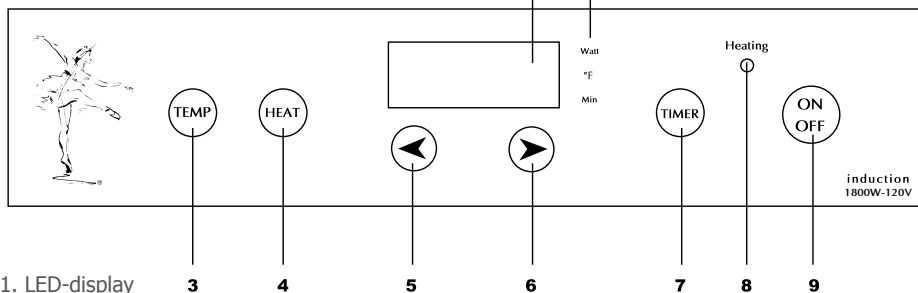

1. LED-display
2. LED-control lamp for power (WATT), temperature (°F) and timer (min)
3. Temperature stage selector
4. Power stage selector
5. Arrow down - reduction of time, temperature, power
6. Arrow up - increase of time, temperature, power
7. Timer selection
8. Input control lamp
9. ON/OFF key/switch

3. Packing, storage & transport

3A. Delivery check

Please check the delivery upon completion and report transport damage immediately upon receipt. In case of visible damage, do not accept or accept the delivery with reservation, only marking the shipping documents with the indication of the extent of damage. Send the complaint to the freight company. Hidden damages should be reclaimed immediately after notice, as claims for damages can only be asserted within the effective period for complaints, usually 48 hours.

3B. Packing

Please do not discard the packing as it might be useful for storage purposes when moving, or in case the device must be sent back for service. Remove packing completely before installation or use.



NOTE!

If you would like to dispose the packing, consider the regulations applied in your area. Please recycle.

Please inspect the device to make sure no parts are missing. Immediately contact our customer service center for claims concerning missing parts.



3C. Storage

Keep the package closed until the device is installed in a dry ventilated place.

- Do not store it outdoors.
- Keep it dry and dust-free.
- Do not expose it to aggressive media.
- Do not expose it to direct sunlight.
- Avoid mechanical shocks and vibration.
- In case of longer storage, more than 3 months, make sure you regularly check the condition of the packing and the device.

4. Preparing your induction cooktop for use

Before the operation of your new induction cooktop begins, you must first do the following:

1. Remove all packing materials.
2. The cooktop must be placed on a dry, level, stable  non-flammable surface.
3. The cooktop must be kept away from other heat sources allowing 2 inches on all sides (front, rear  sides) for proper air circulation. If the air intake or exhaust outlet are blocked, the internal temperature will rise resulting in an error code.

4A. Grounding

The induction cooktop must be properly grounded. This provides safety for you as the user, reducing the risk of electrical shock should an electrical short occur. The cooktop has a grounding plug which must only be used with a compatible outlet. It is the responsibility of the owner of this cooktop to check the wall receptacle. Never cut, remove or disable the electrical connection from the plug. Also never use an extension cord or adapter with the induction cooktop.

Check your cooktop for a removable IEC Power Cord. Before operating your unit, make sure that this power cord is firmly attached before plugging into the receptacle. Note: Not applicable for all models.

4B. Electrical Installation Requirements:

Because every installation site is wired differently, and your local codes may vary, it is the owner's responsibility to comply with those codes. BergHOFF is not responsible for any damages resulting from failure to comply with proper installation.

Read all instructions carefully

Remove unit from carton

Remove all loose packing materials and accessories

It is the responsibility of the installer to comply with all federal and local codes. Warranty of this unit is automatically voided upon any installation not matching the specifications discussed in this manual. BergHOFF recommends a dedicated electrical line be used for each unit installed. Do not share electrical circuits with any other electrical appliance and/or equipment.

BergHOFF's Induction Cooktop has been ETL tested and approved.

For single units only

5. Safety

This segment provides a summary of important safety aspects.

Every chapter provides specific safety tips to avoid danger which is highlighted by the above-mentioned symbols.

In addition, pay attention to all pictograms, markers and labels on the appliance which must always be perfectly legible.

Following all the important safety advice, you gain an optimal protection against all hazards as well as the assurance of a safe and trouble-free operation.

5A. General information

This appliance is designed in accordance with the presently valid industrial standards. However, the appliance can pose a danger if handled improperly or inappropriately. Knowing the contents of the manual as well as avoiding mistakes and thus operating this appliance safely and in a fault-free manner, is essential to protect yourself from any danger. No modifications or alterations to the appliance that are not clearly approved by the manufacturer may be undertaken to avoid any danger and to ensure efficiency. This appliance may only be operated in proper and safe conditions.

5B. Commercial use and safety instructions of this appliance

Regarding industrial safety, the specifications are based on the regulations of the ETL, NSF, FCC applicable at the time of manufacturing the appliance. If the appliance is used commercially, the user is obliged to guarantee that the industrial safety measurements coincide with the rules and regulations applicable at that specific time for the entire period of use of the appliance and must comply with the new specifications. Outside the European Union, the industrial safety laws applied at the place of installation of the device and the regional territorial provisions, must be complied with.

Besides the industrial safety instructions in the instruction manual, the general safety and accident prevention regulations as well as environment protection regulations applicable for the area of application of the appliance must be followed and complied with.

- The appliance should never be left unattended during any operation. Keep away from children and other unqualified individuals.
- Safeguard this manual. When passing on/selling the appliance to a third party, the manuals must be handed over together with the appliance.
- Every individual using the appliance must operate in accordance with the manual and under consideration of the safety information.
- Indoor use only.

5C. Expected use

Safe operation is only guaranteed when using the appliance for its intentional purpose. Any technical interventions, as well as assembly and maintenance are to be made by BergHOFF certified service representatives.

The induction cooktop may not be used for:

- heating and warming inflammable, harmful, volatile or similar liquids or materials
- heating sealed tins; the tin can explode; in any case, remove the cover beforehand a.o..



ATTENTION! CAUTION!

Any use other than the intended purpose and/or any different use of the induction cooktop is prohibited and is not considered as conventional. Any claims against the manufacturer or his/her authorized agent as a consequence of experiencing damages resulting from unconventional use, are not valid. The operator is liable for all damages resulting from improper use.

The anticipated/conventional/suitable usage includes the observance of installation, function, maintenance and cleaning instructions.

6. Installing and operating tips

6A. The function mode and product advantages

While cooking with an induction cooktop, an electric voltage is applied on a conductor spool beneath the glass. This creates magnetic fields, which directly heat up the bottom of the cookware resulting in the heating of your food. This means excellent saving of time and energy, since in contrast to common hobs, the cookware is heated, not the stoves heating element and the glass. Thanks to these technical characteristics, another advantage is the very short start-up cooking time. In addition, the heat supply promptly adapts to changed settings and can be controlled in small steps. The induction cooktop reacts to changed settings just as fast as a gas stove, as the energy reaches the pan immediately without having to heat up other materials first. The induction technology combines this fast reaction with the basic advantage of electricity, meaning being able to precisely adjust the heat supply.

Additional advantages of an induction cooktop

- As the cooking surface is only heated indirectly by the use of the base of the cookware, boiled-over food cannot stick and burn. There is hardly any danger of burns for the user. The glass cooking top is only heated by the hot cookware.

- Once you remove the cookware from the cooking surface, the appliance automatically switches to standby mode.
- The appliance detects whether suitable cookware is placed on the cooking surface. If the cookware is not suitable for induction stoves, no energy is transferred.

6B. General operation and important information:

1810003 Model and some of the typical household use models:

- 1/ Power button
- 2/ Function button toggles between POWER / TEMP COOK / TIMER (where applicable)
- 3/ Power Cook 1-10
- 4/ Temp Cook 60°C - 200°C (140°F - 450°F)
- 5/ Timer (150')
- 6/ Arrow up raises TEMP or POWER, increases TIME
- 7/ Arrow down lowers TEMP or POWER, decreases TIME
- 8/ Cook surface (Black Glass)
- 9/ Cord
- 10/ Feet

For important safeguards on this unit refer to page no 26

All of our other models with designated buttons and on the PRO style models:

- 1/ Power - ON-OFF
- 2/ Power 300 W - 1800 W
- 3/ Temp Cook 60°C - 232°C
- 4/ Timer (150')
- 5/ Arrow up raises TEMP or POWER, increases TIME
- 6/ Arrow down lowers TEMP or POWER, decreases TIME
- 7/ Cook surface (Schott Ceran glass)
- 8/ Cord
- 9/ Feet



(Images for reference only, your model may be slightly different)



(Images for reference only, your model may be slightly different)

When you require a high intense heat, or you need a quick temperature increase, the Power cook mode should be used.

- Make sure that the electrical cord does not come in contact with any heat source or sharp edge. Do not let the cord hang over the table or counter edge.
- Some parts get hot during operation. Do not touch hot parts to avoid injuries!
- Do not use any accessory or spare parts that have not been recommended by the manufacturer. These could be dangerous for the operator or lead to damages of the appliance or cause personal injuries.
- Do not lay the cable on carpets or heat insulations. Do not cover the cable. Keep it away from the operating range and do not submerge it into water or liquid.
- Do not move the induction cooktop during cooking or with hot cookware on top of it.
- Do not place any empty containers on the appliance. It may damage the cooking top and/or the heating unit.
- Do not place any metal objects on the appliance.
- Do not place the induction cooktop next to appliances or objects which quickly respond to magnetic fields (e.g. radios, televisions, cassette recorders, etc.).
- Do not place the induction cooktop next to open flames, heaters or other heat sources.
- The hob's surface consists of temperature-resistant glass. In case of damage, even only a small crack, immediately disconnect the device from the power supply and contact customer service.
- We recommend not placing any metal kitchen utensils, cookware, pan covers, knives or other metal objects on the hob. These may heat up when the appliance is turned on.
- Do not place any magnetic objects like credit cards, cassettes etc. on the glass surface while the device is in operation.
- In order to avoid overheating, do not place any aluminum foil or metal plates on the appliance.
- Scientific tests have proven that induction cooktops do not cause any risk. However, people with a pacemaker should keep a minimum distance of 23 inches from the appliance while it is in operation.
- Do not use the cooktop on a metallic surface.
- Do not disconnect the power cord immediately after cooking, at least 15 seconds is necessary to cool down the stove.
- Do not store the unit outside or upside down.
- Do not obstruct, block or alter the air circulation. Do not stick any foreign object into the air circulation openings.

- Do not place any articles on the unit other than inductive cookware.
- Do not strike the unit causing damage. Do not put the unit into luggage. Throwing or dropping the unit can cause internal damage therefore voiding the warranty.
- If the unit becomes cracked, unplug it immediately and do not use.
- Make sure the outside of your cookware is dry before placing on the unit. Water droplets on the outside of your cookware may begin to boil and spatter.
- Remember to always turn the unit off after each use.

Important: You can switch between TEMP cooking , POWER cooking and TIMER at any time by pressing the FUNCTION button.

When your recipe calls for an even higher temperature to be maintained during the cooking time, you will use the TEMP mode by following these steps:

- Turn the unit to the  position by pressing the Power button.
- Place cookware on the unit.
- Select the TEMP button (or choose with the function button TEMP).
- Adjust the up and down Arrow Keys until the desired cooking temperature appears on the LED display.
- Turn the unit off by pressing the Power button.



NOTE

If the unit is left on and unattended without a pan for more than 8 seconds it will turn off. The LED will display horizontal dashes which tells you it is in this off mode. To exit this mode press the power button back to on.

A thermostat monitors the temperature of the bottom of the pan. For actual food temperature a thermometer should be used.

6C. Induction and non-induction cookware

Induction cookware:

- steel or enamelled cast iron
- iron, steel or non-enamelled cast iron
- 18/10 stainless steel and aluminum, if it is marked as suitable for induction (follow the description of the cookware)

For proper functioning, all cookware must have a plane magnetic base (a magnet must stick to it). We recommend cookware with a diameter between 12 (4 ¾") and 26 cm (10 ¼") for better results.

Non-induction cookware

- cookware with a diameter of less than 12 cm (4 ¾")
- ceramic, glass
- stainless steel, aluminum, bronze or copper unless it is specifically marked as suitable for induction
- cookware with feet
- pan with rounded base (an uneven base such as a Wok)

Please only use cookware marked suitable for induction. Should the hob face a strong deviation in comparison with magnetic utensils, it leads to a drop in performance and can result in the loss of protective action against overheating. Therefore, the use of aluminum, bronze or non-metallic pans should be avoided.

6D. Connection and installation

- Place the cooktop on a stable and level surface.
- Never place the cooktop on a flammable surface (e.g. table cloth, carpet, etc.).
- Do not block the ventilation slots of the cooktop. This may overheat the cooktop.
- Keep a minimum distance of 5 (2") to 10 (4") cm to walls or other items.
- Make sure that the main connection cable is not damaged or compressed beneath the cooktop.
- Make sure that the main connection cable does not get into contact with sharp edges or hot surfaces.
- Do not use any flammable, acid or alkaline materials or substances near the cooktop, as this may reduce the service life of the cooktop and lead to deflagration when the cooktop is turned on.



CAUTION!

Do not touch the hot surface of the glass top. Please note: the induction cooktop does not heat up itself during cooking, but the temperature of the cookware heats up the glass cooking surface.



WARNING! Hazard via electrical current!

Do not insert any objects like wires or tools into the ventilation slots. Attention: this may cause electric shocks.

6E. Operating the cooktop

- Plug the power cord into a suitable outlet.
- A beep signal sounds when the cooktop is in standby mode.
- Place induction suitable cookware in the center of the cooking surface.
- Now press the ON/OFF switch to turn the induction cooktop on. The control lamp "POWER" blinks and an acoustic signal sounds and the unit will start to work at a default Power stage.

2207123

• "POWER"

The pre-set power stage "1300 W" is selected and the device turns on (power stages: 300 – 1800 W). With the arrow keys you can change the settings at any time in a range from 300 – 1800 W. The LED-display "1300 (w)" flashes up. (1/2 the max powersetting, depending on your model (1300W for 2207123), will be the auto-start setting when the unit is first activated).

• "TEMP"

The pre-set temperature stage is selected and the device turns on temperature stages between 60°C – 232°C. With the arrow keys you can change the settings at any time. The LED-display "132 (°C)" flashes up. (132°C is the standard start temp when the unit is first turned on TEMP)

• "TIMER"

After selection of the operating mode (power stage or temperature stage), press the "TIMER" key. The number "15" appears in the display and the LED-display "15:00 (min)" next to the display flashes up. By using the arrow keys, you will be able to adjust the operating time in intervals of 5 minute (5" up 1" down) up to 150 minutes maximum (some units may start at 150 minutes which is the max allowable time of one single use and can be time corrected down from there). The time will be counted down in minute steps, whereupon the display returns to the prior status (POWER, TEMP). If you want to check the cooktime left, just press the "Timer" button again. Once the time is up, an acoustic signal sounds and the device automatically goes in standby mode.



NOTE!

During timer operation, you can change the duration at any time with the arrow keys. With the memory function of the appliance, the power stage or temperature settings remain unchanged here.

1810003

• "Power" (1x pressing the "Function" button)

The pre-set power stage "5" is selected and the device turns on. With the arrow keys, you can

change the settings at any time, ranging from 1-10. LED-display "POWER" appears.

- "Temp" (2x pressing the "Function" button)

The pre-set temperature stage "120°C" is selected and the device turns on. With the arrow keys, you can change the settings at any time, ranging from 60°C - 200°C. LED-display "TEMP (°C)" appears.

- "Timer" (3x pressing the "Function" button)

After having selected the operating mode (power stage or temperature stage), press the "Timer" key. The number "0" appears on the display and the LED-display "TIMER (min)" next to the display appears. By using the arrow keys, you will be able to increase the time in intervals of 5 minutes, up to 150 minutes maximum. You can also decrease the time and this in intervals of 1 minute. Once the time is up, you will hear an acoustic signal and the device automatically enters standby mode.

Just as well, you may adjust the power stage or temperature stage selection without a change of time specification.

- Once the cooking or warming process is finished, disconnect the main plug from the outlet!
- Do not place any empty cookware on the glass top. Heating an empty pot or pan activates the overheating protection and the device turns off but this could occur after your cookware has been damaged.
- Do not operate the device if it is damaged in any way or if it does not function properly.
- The use of accessories and spare parts not recommended by the manufacturer may lead to damage on the device and may cause injuries.

7. Cleaning and safety procedures

7A. Safety advice

- Before moving or cleaning, make sure the appliance has been disconnected from the power socket (pull the power plug!!!) and has completely cooled down.
- Do not use any acidic agents and make sure no water enters the appliance.
- To protect yourself from electric shock, never immerse the appliance, its cables or the plug in water or other liquids.
- Only use a soft cloth and make sure you never use any kind of abrasive agents or pads, which could scratch the surface.
- Regular dish liquid and water are sufficient to remove marks of finger prints, grease

or dirt.

- In exceptional cases, you may use commercial non-abrasive agents or commercial agents that are used for cleaning the glass top.
- After the cleaning procedure, you should use a soft and dry cloth to wipe dry and polish the surface.

7B. Cleaning

- Switch off the cooktop and disconnect the power plug from the socket.
- At first, you should clean the glass field with a damp cloth or a mild, non-abrasive soap solution.
- Wipe off the operating panel with a soft cloth or a mild detergent.
- Do not use any fuel products; this will damage the plastic parts and the operating panel.
- Make sure that the base of the cookware does not scrape across the surface of the glass field, although a scratched surface does not impair the use of the cooktop.
- Make sure that the cooktop is cleaned and dried properly for storage and further usage.

7C. Maintenance

- Check the main connection cable for damage from time to time. Never operate the cooktop when the cable is damaged. If the main connection cable shows defects, have it replaced by a qualified electrician.
- When you encounter damages or failures, contact your specialized dealer or our customer service.
- Only qualified experts may perform repair and maintenance work on the appliance using original replacement and accessory parts. Never attempt to repair the appliance yourself!

8. Waste disposal

Waste devices

At the end of its service life, the discarded device has to be disposed in accordance with the national waste disposal and recycling regulations. It might be advisable to contact a company which specializes in waste disposal.



WARNING!

To avoid risks involved with waste disposal, disconnect the device from the main supply and remove the main connection cable from the device.



NOTE!

For the disposal of the device, follow the local ordinances and regulations applied in your country or region.

9. Warranty Information

Warranty of the BergHOFF Induction Cooktop is against defects in materials and workmanship for a period of one year from the date of sale.

IMPORTANT!! Keep a copy of your sales receipt to verify date of purchase. You must provide proof of purchase, and date of purchase to obtain the warranty of the unit. Warranty applies to the original purchaser and is non-transferable. Any defects in materials or workmanship which are brought to the attention of BergHOFF by written notification within the warranty period will be repaired or replaced, at BergHOFF's discretion, with new or recertified products or parts.

This is the sole remedy for any breach of this warranty. In no way will BergHOFF be liable for damages of any kind, whether direct or indirect, special or consequential. This warranty is the complete and only warranty, expressed or implied in law or fact, including but not limited to, warranties of merchantability, suitability, quality, or fitness for any particular purpose.

This warranty is void if it is determined that upon inspection by the authorized service agent, the equipment has been modified, misused, misapplied, improperly installed, or damaged in transit or by fire, flood or act of God. Warranty will be considered void if the unit has been opened or modified in any way, or service has been attempted by unauthorized personnel. The prices charged by BergHOFF for its products are based upon the limitations in this warranty. Seller's obligation under this warranty is limited to the repair of covered defects without charge by a BergHOFF factory authorized service agent, or one of its sub-service agencies.

To receive warranty service, please contact BergHOFF at 2323 Merchant Ave, Odessa, FL 33556 or cs@berghoff-usa.com to obtain an RA number. This RA number must be printed on the outside of the return shipping box, or on the address label when returning units for service. Units received without an RA number will be refused at our shipping dock and may encounter a delay in service. Units must be taken or shipped to the required authorized service agency with transportation charges prepaid for service. BergHOFF will provide return freight. In addition to restrictions contained in this warranty, specific limitations are shown in the service policy and procedure guide. Please save all packaging materials for possible use in shipping. BergHOFF assumes no liabilities whatsoever for any damages incurred in transit.

This warranty is valid in countries in which BergHOFF products are sold and void elsewhere. For additional information and other details concerning warranty, please contact our service department at: BergHOFF Customer Service Department, 2323 Merchant Ave, Odessa, FL 33556 or cs@berghoff-usa.com <mailto:cs@berghoff-usa.com>. Worldwide Web: www.berghoffworldwide.com

10. Error code list:

– If LED-display shows the error code, please reference to the solution as following.

Error code	Cause and solution
E1	Voltage is under 95V
E2	Voltage is over 145V
E3	The accessory and spare parts are damaged, please contact the nearest authorized service facility for trouble shooting, repair and adjustment.
E4	The accessory and spare parts are damaged, please contact the nearest authorized service facility for trouble shooting, repair and adjustment.
E5	The accessory and spare parts are damaged, please contact the nearest authorized service facility for trouble shooting, repair and adjustment.
E6	The cooking temperature is over 200°C in the function mode "TEMP". After the unit has been cooled down, the unit would be automatic switches to standby mode.
E7	Ventilation blocked, heat can not be blew out of the machine smoothly, it causes device inside over-heat. Please keep a minimum distance of 5 to 10 cm of the device to walls or other items. Please power off to eliminate the wrong record and let the unit cool down, and then re-plug the power cord and restart the unit
E8	The cooking temperature is over 150°C in the function mode "Power" to cook, the max temperature is 150°C. If the cooking temperature is over 150°C in this mode, the unit would be appeared the error. Please power off to eliminate the wrong record and let the unit cool down, and then re-plug the power cord and restart the unit. If you would like the cooking temperature is over 150°C, please use the function mode "TEMP", the max temperature is 200°C.
E9	Using the cookware without the magnetism bottom or the diameter of the bottom is less than 12cm, please use the cookware with magnetism and flat bottom. Such as the iron or cast iron cookware, the cookware with 18/0 stainless steel bottom. And the cookware with the diameter of the bottom is 12 to 26cm, please use the suitable cookware, then the unit would be automatic restarted.

* The cooking temperature is right the temperature of the glass center.

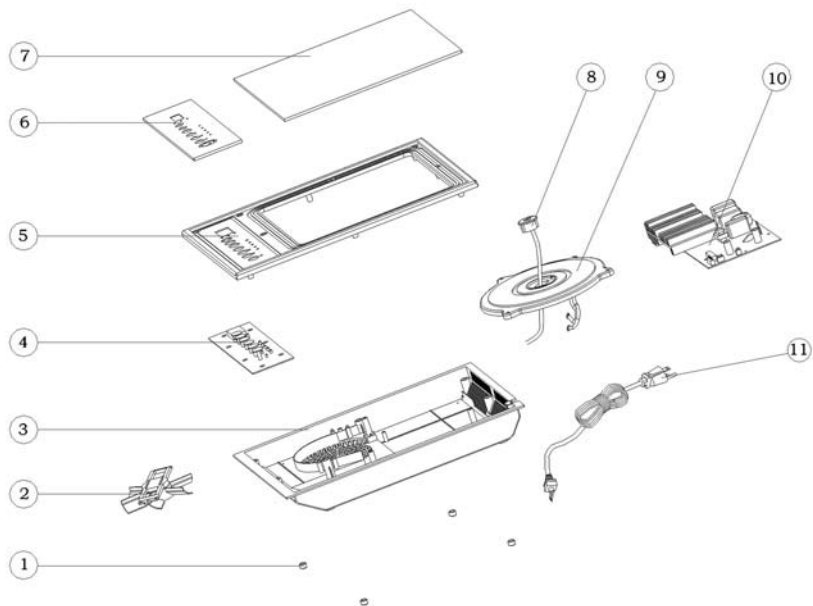

Induction cooktop Diagram 1

- 1) Feet
- 2) Motor
- 3) Base
- 4) Control Panel
- 5) Frame
- 6) Control panel
- 7) Glass
- 8) Thermostat Device
- 9) Coil
- 10) Electrical Board
- 11) Plug

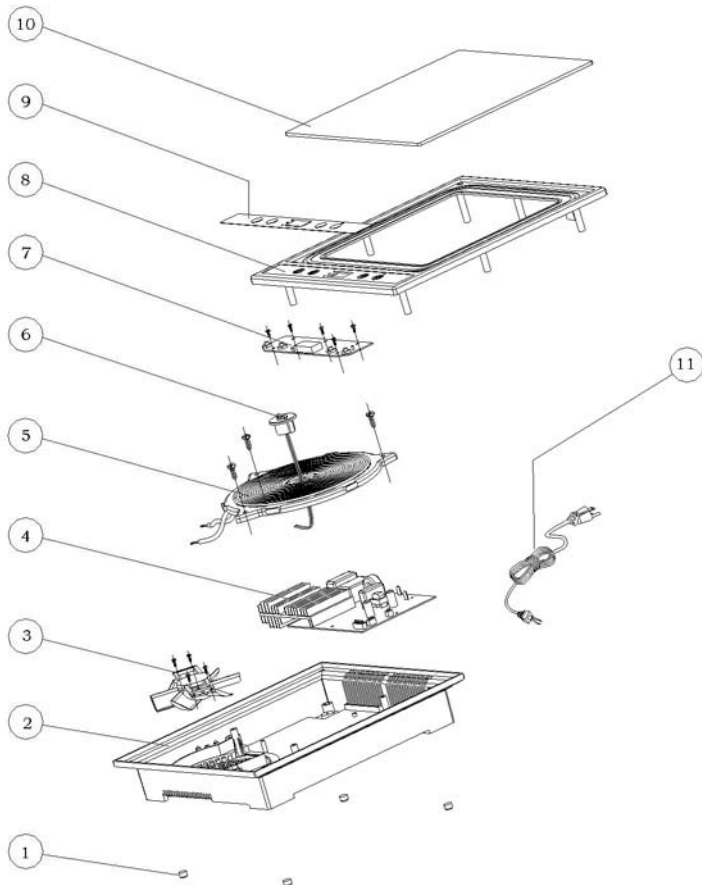

Induction cooktop Diagram 2

- 1) Feet
- 2) Base
- 3) Motor
- 4) Electrical Board
- 5) Coil
- 6) Thermostat Device
- 7) Control Panel
- 8) Frame
- 9) Control panel contact
- 10) Glass
- 11) Plug

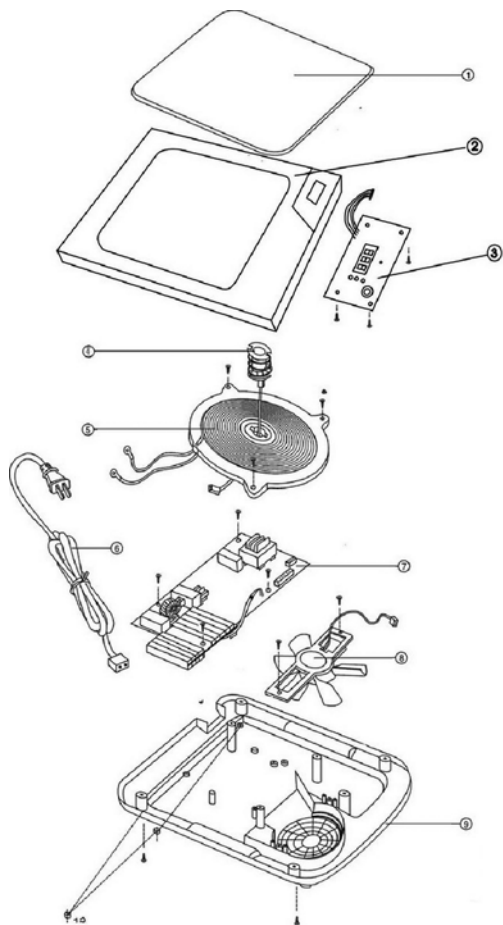

Induction cooktop Diagram 3

- 1) Black glass
- 2) Frame
- 3) Control Panel
- 4) Thermostat Device
- 5) Coil
- 6) Plug
- 7) Electrical Board
- 8) Motor
- 9) Base
- 10) Feet

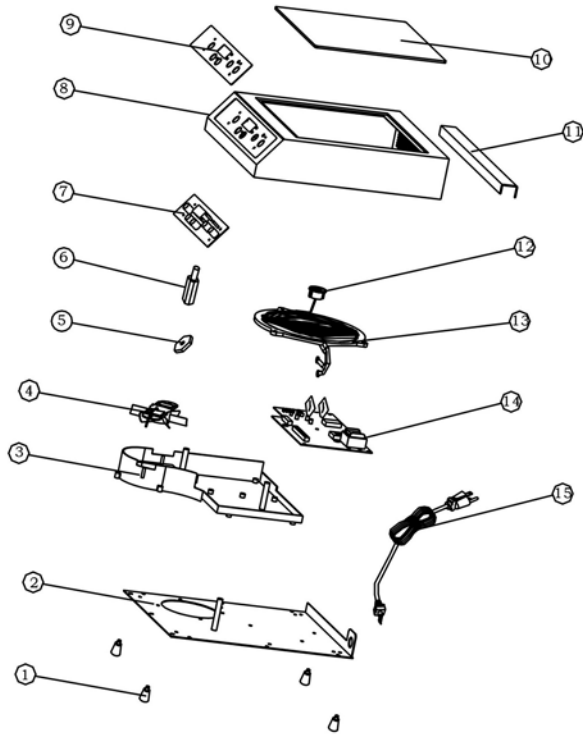

Induction cooktop Diagram 4

- 1) Feet
- 2) Base
- 3) Support for Electrical Board
- 4) Motor
- 5) Nut for Control Panel
- 6) Screw for Control Panel
- 7) Control Panel
- 8) Frame
- 9) Control panel contact
- 10) Glass
- 11) slot
- 12) Thermostat Device
- 13) Coil
- 14) Electrical Board
- 15) Plug

IMPORTANT SAFEGUARDS

When using electrical appliances, basic safety precautions should always be followed including the following:

Read all instructions.

1. Do not touch any hot surfaces. Use the handles or knobs.
2. To protect against electrical shock, do not immerse cord, plugs, or appliance in water or other liquid.
3. Close supervision is necessary when the appliance is used by or near children.
4. Unplug from outlet when not in use and prior to cleaning. Allow unit to cool before putting on or taking off parts.
5. Do not operate the appliance with a damaged cord or plug or after the appliance malfunctions or has been damaged in any manner. Return the appliance to the nearest authorized service facility for examination, repair, or adjustment.
6. The use of accessory attachments is not recommended by the appliance manufacturer and may cause injuries.
7. Do not use outdoors, household use only.
8. Do not let cord touch hot surfaces or hang over the edge of a table or counter.
9. Do not place on or near a hot gas or electric burner, or in a heated oven.
10. To disconnect, turn any control to off, then remove the plug from wall outlet.
11. Do not use the appliance for anything other than the intended use.
12. Do not immerse in water.
13. Do Not Cook on a Broken Cook-Top. If cook-top should break, cleaning solutions and steam may penetrate the broken cook-top and create a risk of electric shock.
14. Clean Cook-Top with Caution. If a wet sponge or cloth is used to wipe spills on a hot cooking area, be careful to avoid a steam burn, some cleaners can produce noxious fumes if they are applied to a hot surface.
15. Caution - To ensure continued protection against risk of electric shock, connect the appliance to properly grounded outlets only.
16. Do not heat empty or overheat it.
17. Do not place metallic objects such as; knives, forks, spoons, lids, cans and aluminum foil on the cook-top.



18. Allow sufficient space around the cooking area.
19. Never use the unit on low-heat-resistant materials (carpet, vinyl).
20. Do not place a sheet of paper between the pot or the pan and the unit. The paper may get burnt.
21. Be aware that the unit surface will remain hot for a short period of time.
22. Items with a magnetic field, such as: radios, televisions, automatic-banking cards and cassette tapes, can affect the unit.

SAVE THESE INSTRUCTIONS

Power Cord:

- A short power-supply cord is to be provided to reduce the risk resulting from becoming entangled in or tripping over a longer cord.
- If an extension cord is available, it may be used if care is exercised in its use.
- If an extension cords power-supply cord is used,
 - 1) For 2207123: the extension cord should be a grounding-type 3-wire cord, the marked electrical rating of the extension cord should be at least as great as the electrical rating of the appliance, and
 - 2) The cord should be arranged so that it will not drape over the countertop or tabletop where it can be pulled on by children or tripped over unintentionally.

SPECIFICATION:

	2207123	1810003
Power	1800 W	1600 W
Voltage	120V/60Hz	120V/60Hz
Temperature:	60°C - 232°C 	60°C - 200°C 

HOW TO USE

1. Before turning on the power, make sure the cookware is on the ceramic plate with ingredients inside.
2. To turn the power on, press the ON/OFF button once. The power light will turn a steady red and heating will begin
3. To select the proper heat setting, press the REDUCE or INCREASE until the correct heat setting is achieved.(defaults=5)

4. To select temperature setting, press the "TEMP" button once (defaults=120°C), the temperature light will turn a steady red, and press the REDUCE or INCREASE until the correct temperature setting is achieved.
5. To select automatic timer setting, press the "TIMER" button twice (defaults =0mins), the timer light will turn a steady red, and press the REDUCE or INCREASE button until the correct timer setting is achieved. You will be able to select the operating time in increasing 5 minutes, and reducing 1 minute. (The timer is between 0 to 150 minutes)
6. After the cooking is completed, press the ON/OFF button again to turn off the unit.
7. When the unit has been used excess 150mins, it will show "EE" as error code from the LED window. the unit will automatically stop, to press ON/OFF button to restart the unit.

 **NOTE:** The power will completely shut off within 9 seconds either (a) the wrong type of cookware is applied or (b) no cookware is placed on the unit.

USABLE AND NON-USABLE UTENSILS:

- Compatible Pans: Steel or cast iron, enameled iron or 18/10 stainless steel, all with flat-bottoms and a with a diameter of 12 to 26 cm.
- Non- compatible Pans: Heat-resistant glass, ceramic container, copper, aluminum pan/pots. Rounded-bottom pan/pots with the base measuring less than 12 cm.

HOW TO CLEAN:

- Clean after each use. Disconnect plug and wait until the unit has cooled down.
- If the pots/pans that are used are not clean, staining or dis-colorization may occur.
- Do not use benzene, thinner, a scrubbing brush or polishing powder to clean the induction cooker.
- Wipe down the unit using a dish washing agent and a damp cloth.
- Use a vacuum cleaner to suck up dirt from the air intake and exhaust vent.
- Never run water over the unit (If water gets inside it may cause malfunction).

 **WARNING:** Any other servicing should be performed by an authorized service representative.