



FEATURES & SPECIFICATIONS

CPX Smart panel from Lithonia Lighting® with motion sensor is the perfect choice for a quality LED panel at an affordable price. This smart home lighting solution uses Bluetooth or Zigbee to pair to your mobile device or compatible smart home hub. It is also certified with SmartThings, Alexa and Google Home platforms.

INTENDED USE:

Smart CPX with Motion Sensor is a low-glare panel featuring an external driver. This cost-effective, reliable panel is visually comfortable and can be recessed mounted. Suitable for many applications such as schools, offices, retail, convenience stores and other commercial spaces. Available in both 2x2 and 2x4 Configurations. Certain airborne contaminants can diminish integrity of acrylic. [Click here for Acrylic Environmental Compatibility table for suitable uses.](#)

CONSTRUCTION:

The extruded aluminum frame with satin white lens provides excellent shielding and uniform luminance. The low-profile design of CPX provides increased installation flexibility especially in restricted plenum spaces. The backplate includes integral T-bar clips for installation into T-grid ceilings.

ELECTRICAL:

Long-life LEDs, coupled with a high-efficiency driver, provide superior illumination for extended service life. Greater than 70% LED lumen maintenance at 50,000 hours (L70>50,000). Dims to 1% via SmartThings App. Motion sensor: 10 min. default out of the box. Adjustable timeout between 1min.-23:59 hr:min, detection range 15ft.

LISTINGS:

CSA certified to meet US and Canadian standards. Damp location listed. IC rated. IP5X Rated. ENERGY STAR®. NOM Certified.

CONNECTIVITY:

- App light output dimming: 100% default 1%-100% adjustable.
- App Color tuning: 4000K default 2700K-5000K adjustable.
- Apps: SmartThings BLE direct to phone, SmartThings hub, Google Home, Alexa.

WARRANTY:

3-year limited warranty. This is the only warranty provided and no other statements in this specification sheet create any warranty of any kind. All other express and implied warranties are disclaimed. Complete warranty terms located at: www.aucuitybrands.com/support/warranty/terms-and-conditions

Note: Actual performance may differ as a result of end-user environment and application. All values are design or typical values, measured under laboratory conditions at 25 °C. Specifications subject to change without notice

WEIGHT:

2x2
Unit: 6.39lbs
Unit Carton: 7.72lbs
Master Carton: 30.42lbs

2x4
Unit: 11.02lbs
Unit Carton: 13.89lbs
Master Carton: 27.78lbs

Catalog Number
Notes
Type

Smart CPX

LED Panel with Motion Sensor
2'x2' and 2'x4'



Catalog Number	UPC	Description	Lumens	Input Watts	CCT	CRI	Voltage	Pallet Qty.
CPXC 2X2 TUWH 120 M4	196182570100	CPXC 2X2 Smart Panel	See Switchable Table	40	Tunable White (2700 to 5000K)	80	120-277	40
CPXC 2X4 TUWH 120 M2	196182570094	CPXC 2X4 Smart Panel	See Switchable Table	40	Tunable White (2700 to 5000K)	80	120-277	20

Smart CPX Performance Data					
Size(ft)	Nomenclature	CCT (K)	Lumen	Watt	Efficacy
2x2	CPXC 2X2 TUWH 120 M4	2700K	3519	42.66	82.5
		3000K	3621	39.55	91.6
		3500K	3874	38.78	99.9
		4000K	3918	38.86	100.8
		5000K	3900	42.15	92.5
2x4	CPXC 2X4 TUWH 120 M2	2700K	4486	46.87	95.7
		3000K	4460	43.75	102
		3500K	4740	43.44	109.4
		4000K	4825	43.48	111
		5000K	5083	47.61	106.8

Smart CPX LED Panel

Accessories: Order as separate catalog number.

ILBLP CP10 HE SD A	IOTA 10 Watt Constant Power, High Efficiency LED Emergency Driver for CA Title 20 ¹
DGA14	Drywall grid adapter for recessed fixture.
DGA22	Drywall grid adapter for 2x2 recessed fixture.
DGA24	Drywall grid adapter for 2x4 recessed fixture.
1X4SMKSH	Multi-Use Surface Mount Kit, Shallow Depth
2X2SMKSH	Multi-Use Surface Mount Kit 2x2, Shallow Depth
2X4SMKSH	Multi-Use Surface Mount Kit 2x4, Shallow Depth
1X4SMKSH PAF	Multi-Use Surface Mount Kit Post-Paint
2X2SMKSH PAF	Multi-Use Surface Mount Kit 2X2 Post-Paint
2X4SMKSH PAF	Multi-Use Surface Mount Kit 2X4 Post-Paint
PAC 2DNF 36	Panel Air Craft Kit, 2 cables with Y splitter, No Power Feed, 36 inches. Recommended for or 2X2 Panel Fixtures only.
PAC 2DF 36	Panel Air Craft Kit, 2 cables with Y splitter, with Power Feed, 36 inches. Recommended for or 2X2 Panel Fixtures only. ¹
PAC 4DNF 36	Panel Air Craft Kit, 4 cables, No Power Feed, 36 inches. Recommended for 2X4, or 2X2 Panel Fixtures.
PAC 4DF 36	Panel Air Craft Kit, 4 cables, with Power Feed, 36 inches. Recommended for 2X4, or 2X2 Panel Fixtures. ¹
PAC 2DNF 72	Panel Air Craft Kit, 2 cables with Y splitter, No Power Feed 72 inches. Recommended for or 2X2 Panel Fixtures only.
PAC 2DF 72	Panel Air Craft Kit, 2 cables with Y splitter, with Power Feed, 72 inches. Recommended for or 2X2 Panel Fixtures only. ¹
PAC 4DNF 72	Panel Air Craft Kit, 4 cables, No Power Feed, 72 inches. Recommended for 2X4, or 2X2 Panel Fixtures.
PAC 4DF 72	Panel Air Craft Kit, 4 cables, with Power Feed, 72 inches. Recommended for 2X4, or 2X2 Panel Fixtures. ¹
RK8BDP 2P U	Disconnect Plug (BDP), 2 Pole, Package of 1
RK8BDP 3P U	Disconnect Plug (BDP), 3 Pole, Package of 1
RK8BDP 2P J10	Disconnect Plug (BDP), 2 Pole, Package of 10
RK8BDP 2P J40	Disconnect Plug (BDP), 2 Pole, Package of 40

Smart CPX LED Panel

DIMENSIONS

Length: 23.8" 60.5cm
Width: 23.8" 60.5cm
Depth: 1.7" 4.3cm

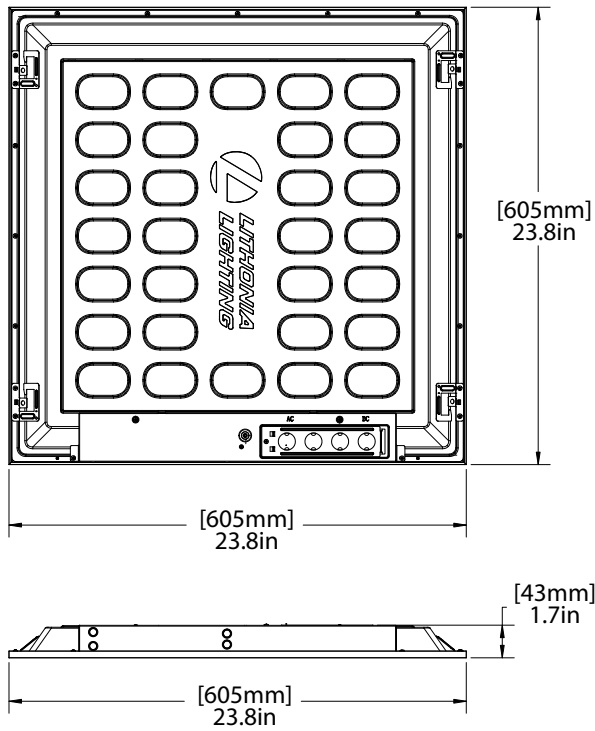

Length: 47.8 (121.4)
Width: 23.8" 60.5cm
Depth: 1.7" 4.3CM

