

6021-10159 2-Tier Garment Rack

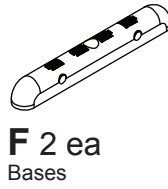
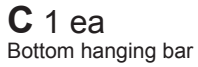
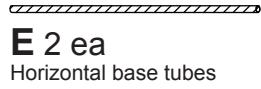
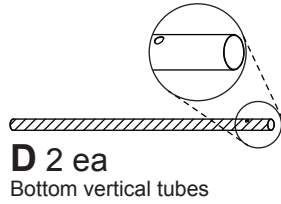
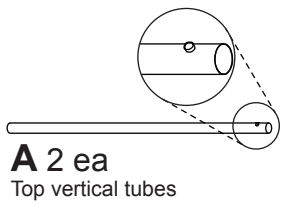

Part	Reference
A	F10877
B	F10878
C	F10879
D	F10876
E	F10880
F	F10881
G	F10882
H	F10883
I	F10257
J	F10258

Tools Needed:
No tools required.

STEP 1: Assemble the base.

- Insert two horizontal base tubes (E) into two bases (F).

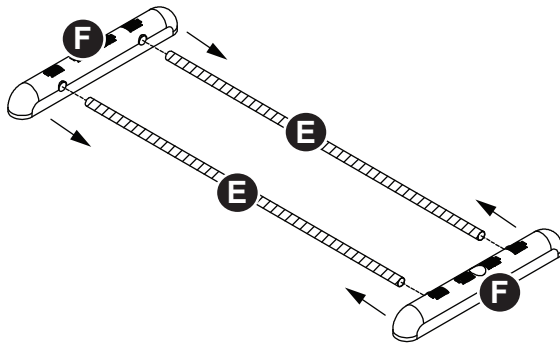

STEP 2: Assemble the bottom hanging bar.

- Insert bottom hanging bar (C) into two middle connectors (H).
NOTE: Make sure to press each side in.

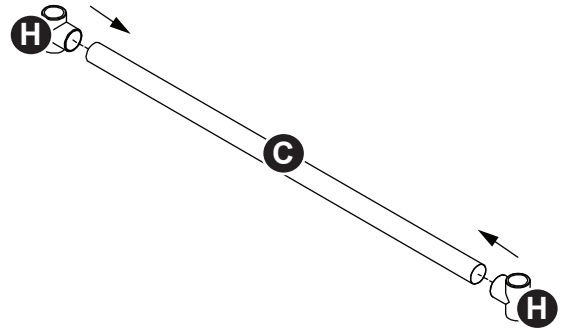

STEP 3: Assemble the top hanging bar.

- Insert top hanging bar (B) into two corner connectors (G).
NOTE: Make sure to press each side in.

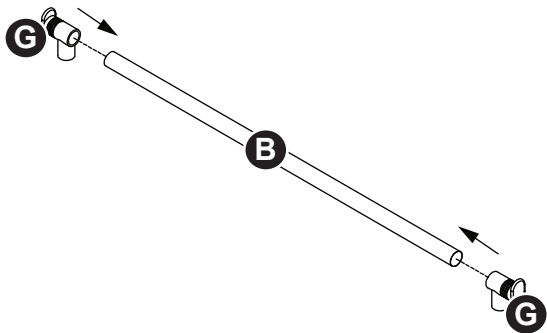

STEP 4a: Assemble rack.

- Insert two bottom vertical tubes (D) into the assembled base.

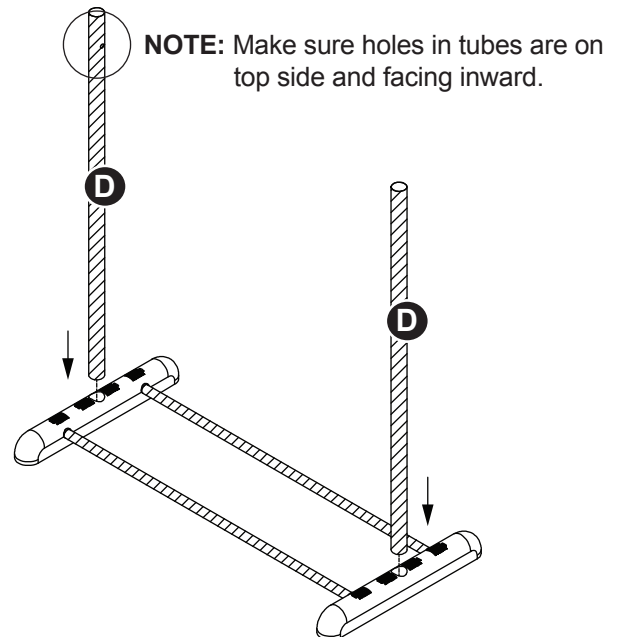

STEP 4b: Assemble rack.

- Attach bottom hanging bar and middle connectors (C+H) to the bottom vertical tubes (D).
- Place push button side of top vertical tubes (A) into the unit until push button clicks into hole.

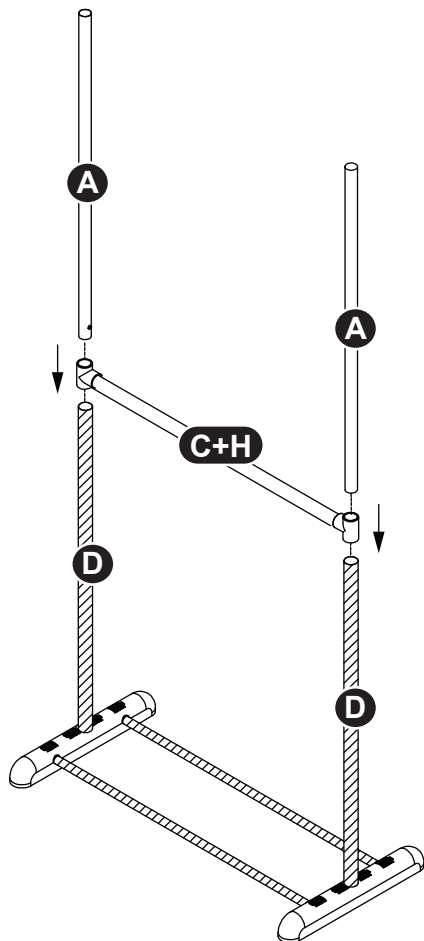

STEP 4c: Assemble rack.

- Attach top hanging bar and corner connectors (B+G) to the top vertical tubes (A).

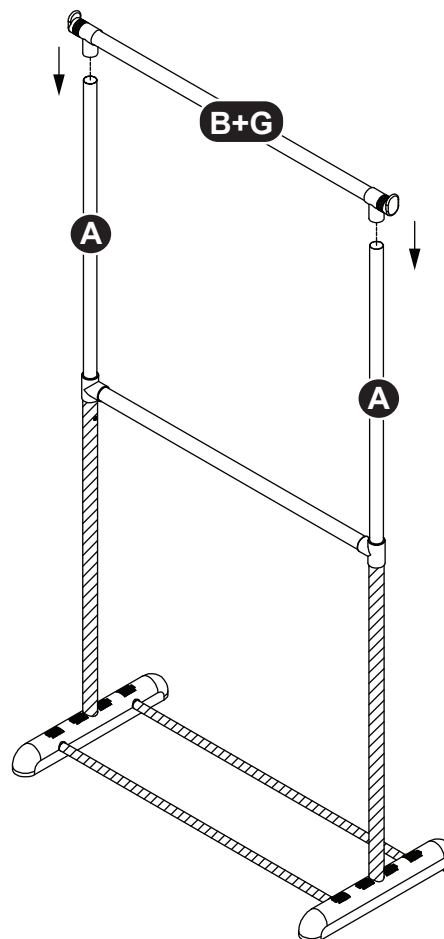

STEP 5: Attach wheels.

- Attach two locking wheels (I) and two wheels (J) to the bottom as shown.

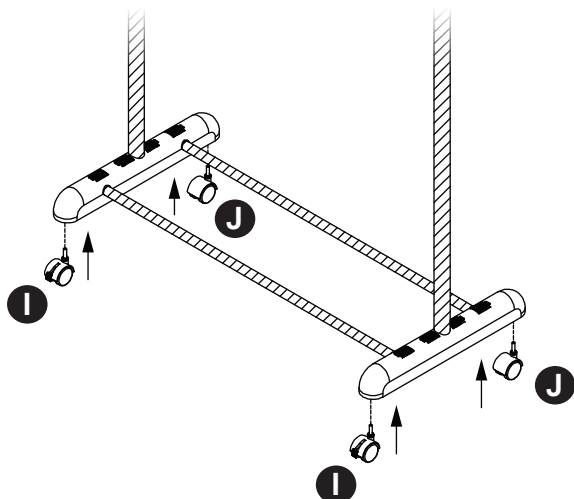

8680 Swinnea Road • Suite 103 • Southaven, MS • 38671

NEED HELP? For help with assembly, or if you are missing a part, please call Whitmor's Consumer Care Team, 1-888-944-8667 between 8 a.m. and 4:30 p.m. (Central Standard Time) Monday through Friday. Or email: help@whitmor.com. Visit us online at www.whitmor.com

Rev#0 10.28.20

Printed in Taiwan